

ASSEMBLY INSTRUCTION

PATIO DOUBLE LOUNGE

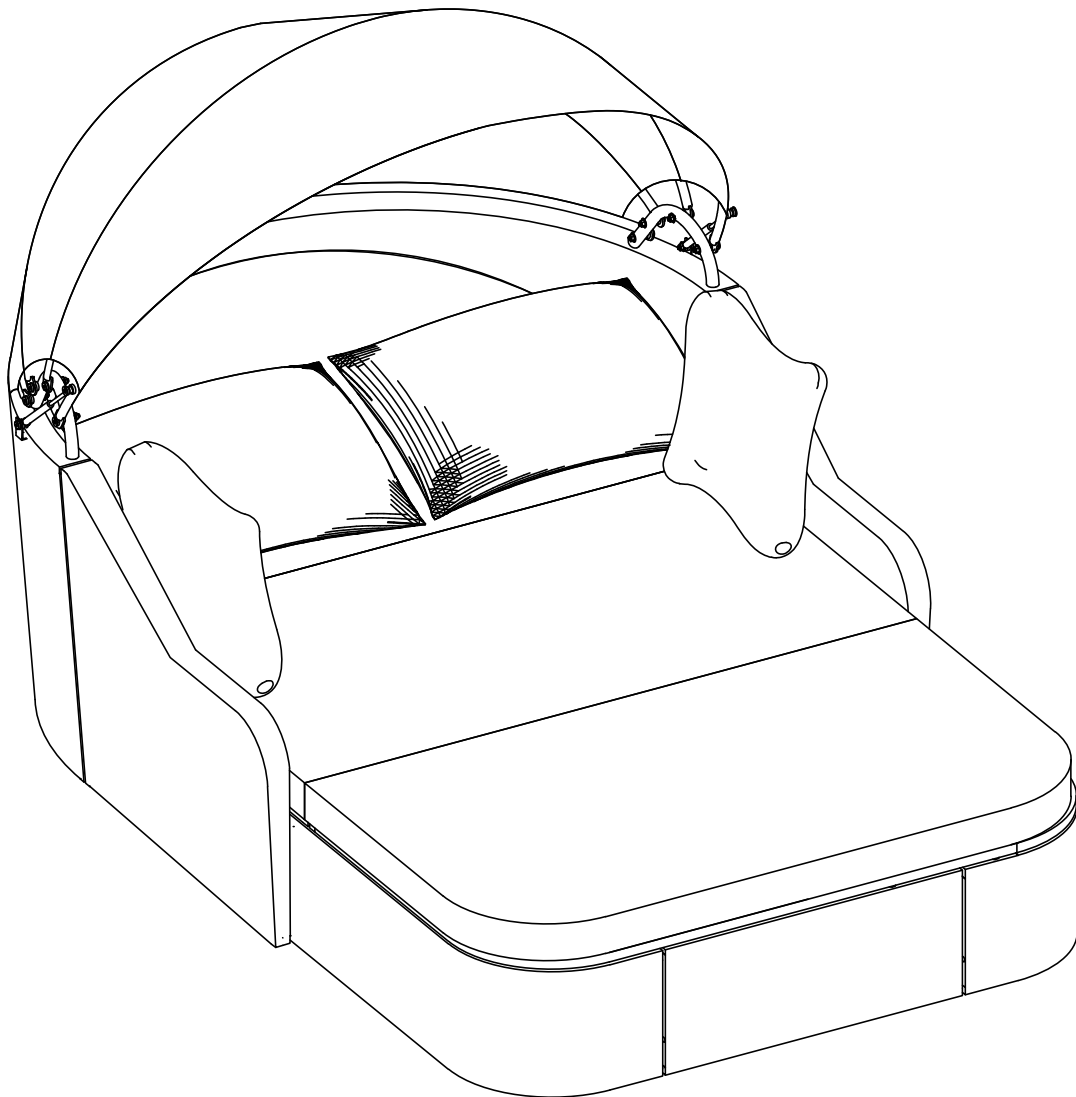

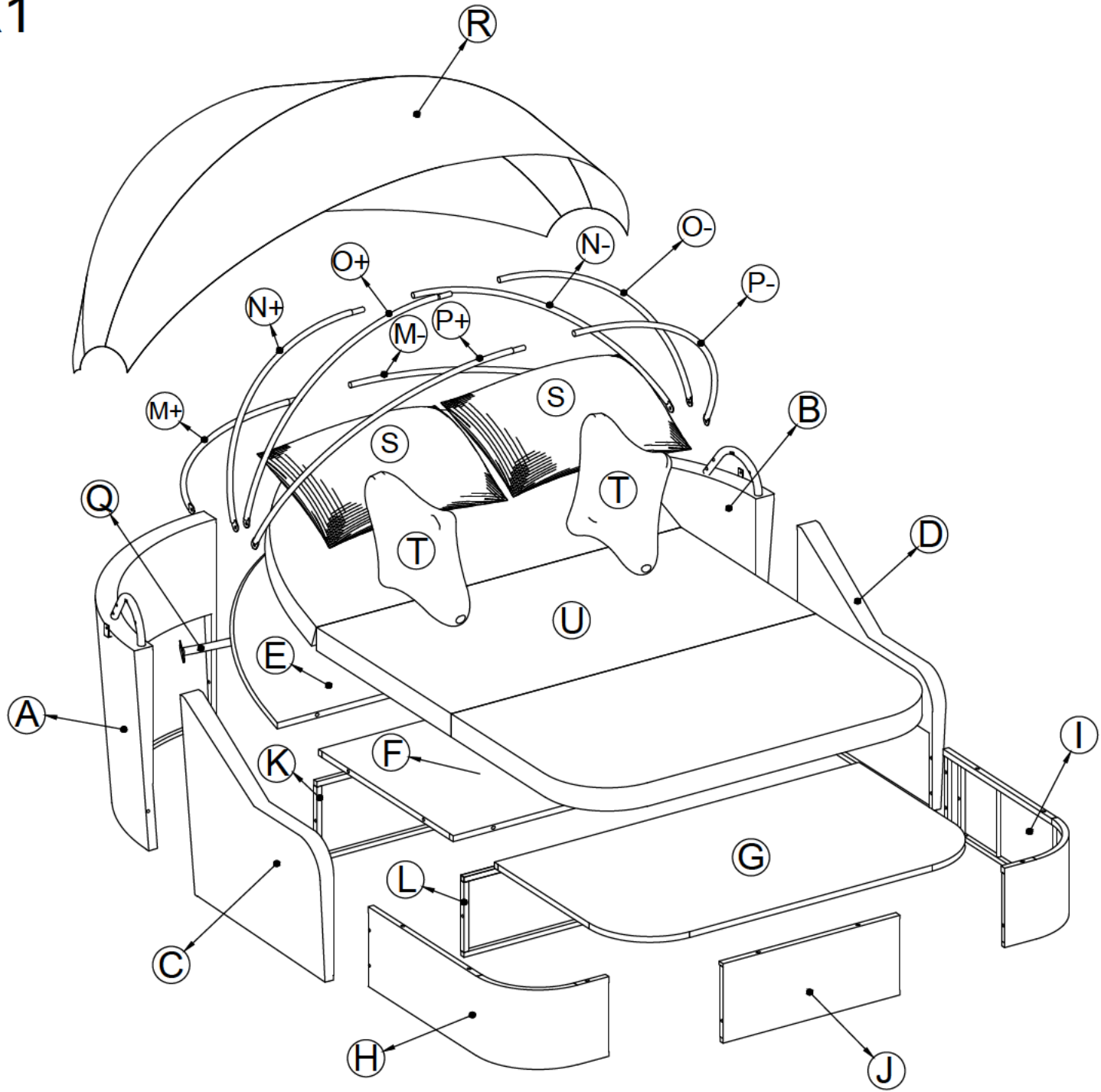







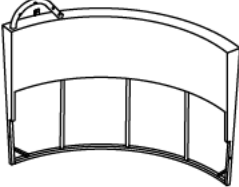
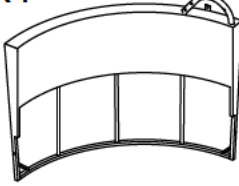
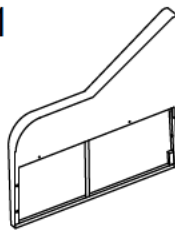
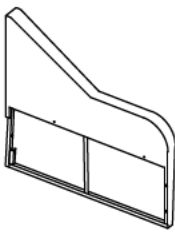
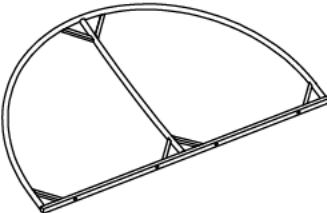
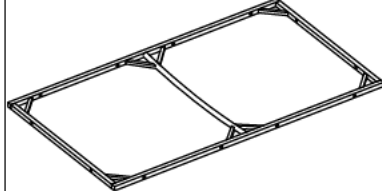
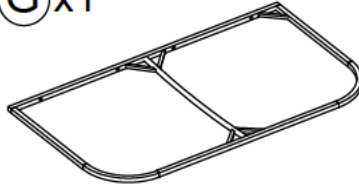
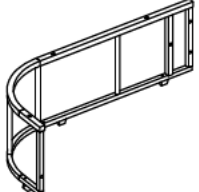
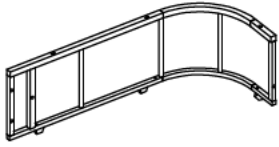
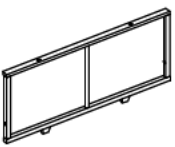
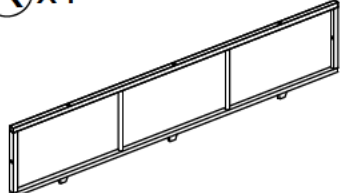
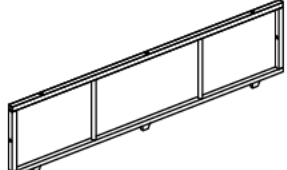



X1



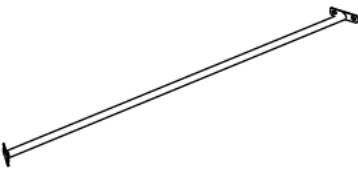

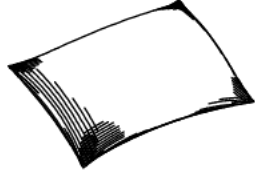

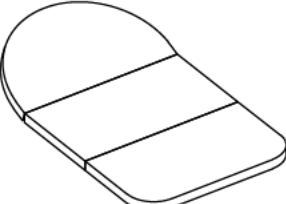
- Note:**
1. 50% Tighten before fixing all screws, Allen wrench is recommended instead of an electric drill.
 2. Place the item on a flat ground to adjust and make sure it remains stable.
 3. Tighten up all screw with tools gradually.
 4. If screw are not aligned with holes during assembly, please loosen all the other screws to 50% and continue the assembly process.
 5. If the item is not stable, please loosen all screws, adjust it on a flat ground and tighten up all screws again.
 6. Note: If one or some screws are fully tighten during assembly, chances are the others will not be aligned with holes. In addition, all the holes are designed to be relatively larger to provide more space for the adjustment of the screws.

Part List:

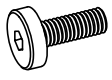
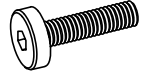
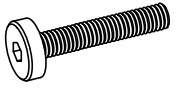
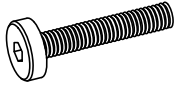
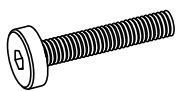
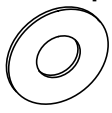
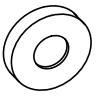
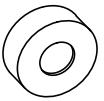
<p>(A)x1</p>  <p>Back Right</p>	<p>(B)x1</p>  <p>Back Left</p>	<p>(C)x1</p>  <p>Arm Right</p>	<p>(D)x1</p>  <p>Arm Left</p>
<p>(E)x1</p>  <p>Front Seat Lounge</p>	<p>(F)x1</p>  <p>Middle Seat Lounge</p>	<p>(G)x1</p>  <p>Behind Seat Lounge</p>	<p>(H)x1</p>  <p>Side Right Lounge</p>
<p>(I)x1</p>  <p>Side Left Lounge</p>	<p>(J)x1</p>  <p>Front Lounge</p>	<p>(K)x1</p>  <p>Front Bare</p>	<p>(L)x1</p>  <p>Middle Bare</p>
<p>(M+)x1</p>  <p>Support M+</p>	<p>(M-)x1</p>  <p>Support M-</p>	<p>(N+)x1</p>  <p>Support N+</p>	<p>(N-)x1</p>  <p>Support N-</p>
<p>(O+)x1</p>  <p>Support O+</p>	<p>(O-)x1</p>  <p>Support O-</p>	<p>(P+)x1</p>  <p>Support P+</p>	<p>(P-)x1</p>  <p>Support P-</p>
<p>(Q)x1</p>  <p>Support Back</p>	<p>(R)x1</p>  <p>Covered</p>	<p>(S)x2</p>  <p>Back Cushion</p>	<p>(T)x2</p>  <p>Pillow Cushion</p>
<p>(U)x1</p>  <p>Seat Cushion</p>			

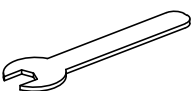
Hardware List:

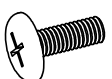
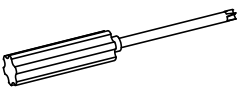
<p>① x 4 pcs Extra 1 pc</p>  <p>BOL M 20M</p>	<p>② x 4 pcs Extra 1 pc</p>  <p>BOLT M6 x 25MM</p>	<p>③ x 16 pcs Extra 2 pcs</p>  <p>BOLT M6 x 35MM</p>	<p>④ x 21 pcs Extra 3 pcs</p>  <p>BOL M 40M</p>
<p>⑤ pcs Extr p</p>  <p>BOL M 70M</p>	<p>⑥ x 71 pcs Extr pc</p>  <p>FLAT WASHER M6</p>	<p>⑦ x 8 pcs Extra 1 pc</p>  <p>WASHER M6 x 5MM</p>	<p>⑧ pcs Extr pc</p>  <p>WASHE M 10MM</p>
<p>⑨ x 18 pcs Extra 2 pcs</p>  <p>NU M</p>	<p>⑩ x 10 pcs Extra 2 pcs</p>  <p>COVE NU M</p>	<p>⑪ p</p>  <p>KE</p>	<p>⑫ pcs</p>  <p>ALLEN KEY</p>
<p>⑬ pcs</p>  <p>GASLIF</p>	<p>⑭ pcs Extr pc</p>  <p>BOL M 10M</p>	<p>⑮ pc</p>  <p>SCRE DIVER</p>	

CARTON CONTENT:

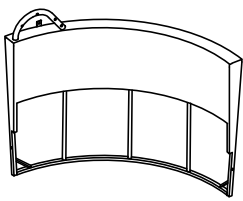

A x1

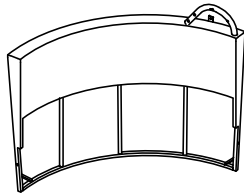

B x1

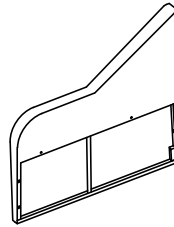

C x1

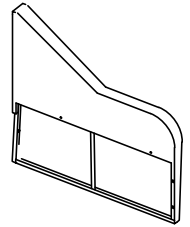

D x1

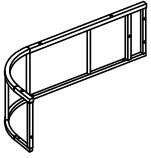

H x1

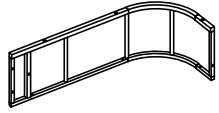

I x1

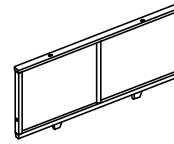

J x1

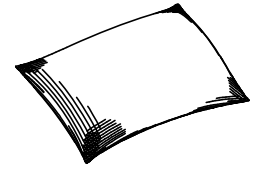

S x2



T x2

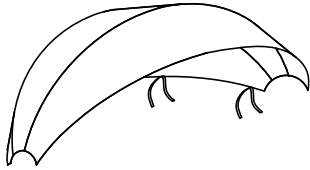

R x1

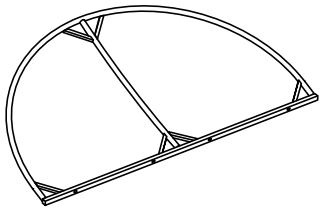

E x1

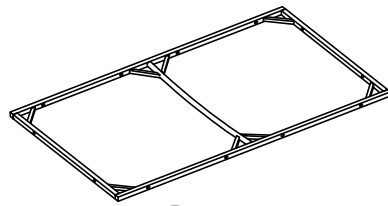

F x1

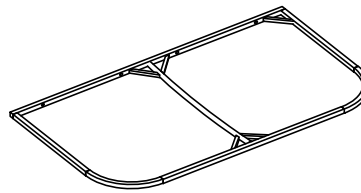

G x1

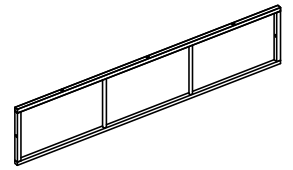

K x1

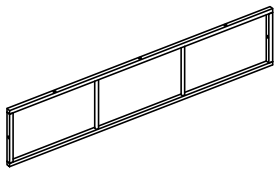

L x1

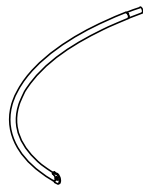

M+ x1



M- x1

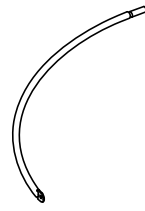

N+ x1



N- x1

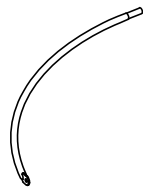

O+ x1



O- x1

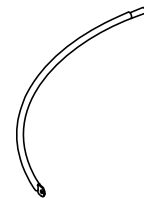

P+ x1



P- x1

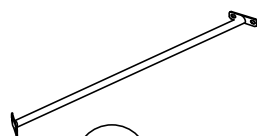

Q x1

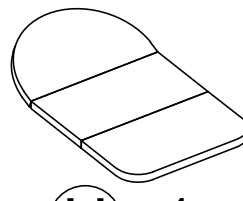

U x1



Hardware

STEP 1

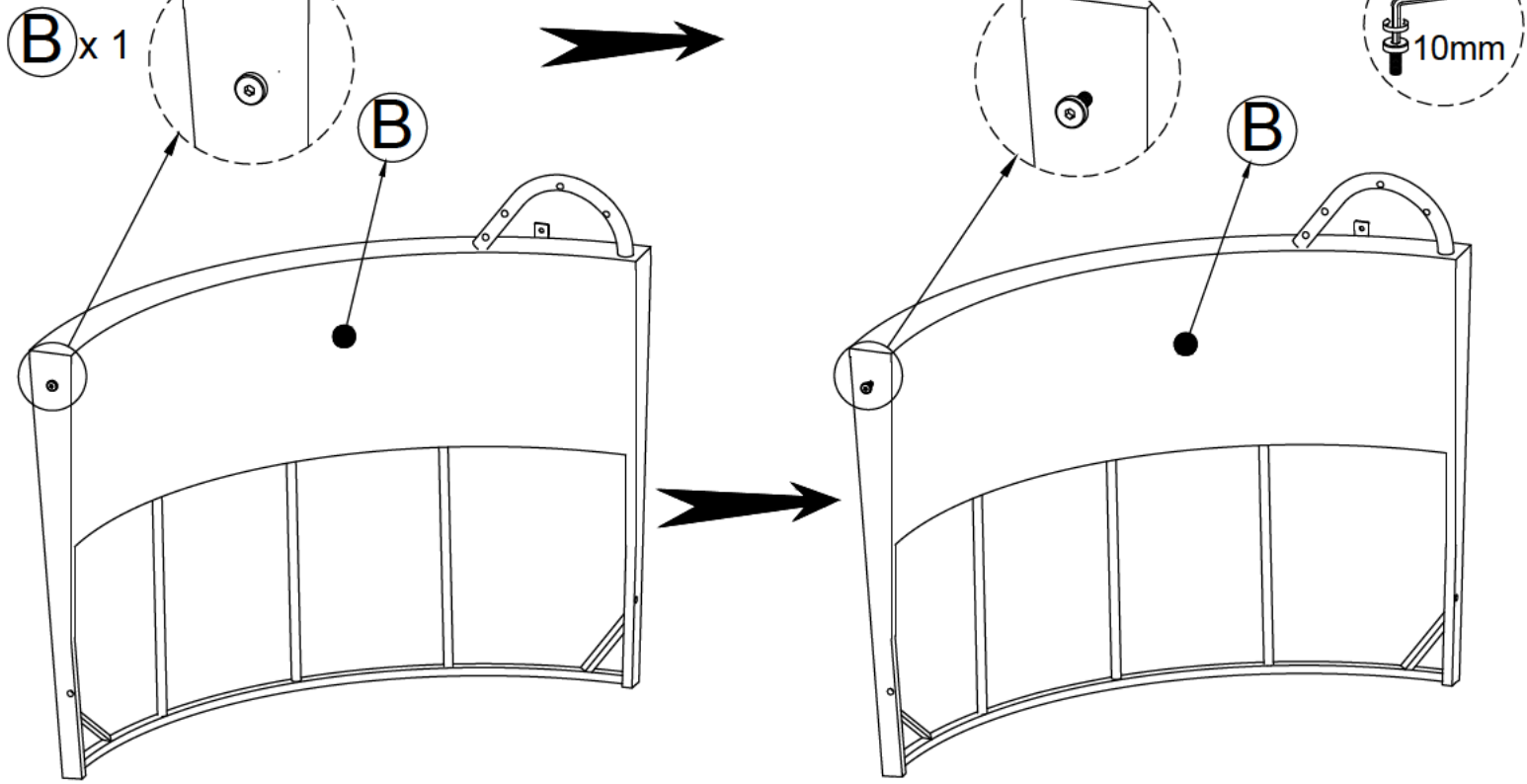

Use Allen key to loosen Bolt on the side of Back Left (B) about 10 mm.

STEP 2

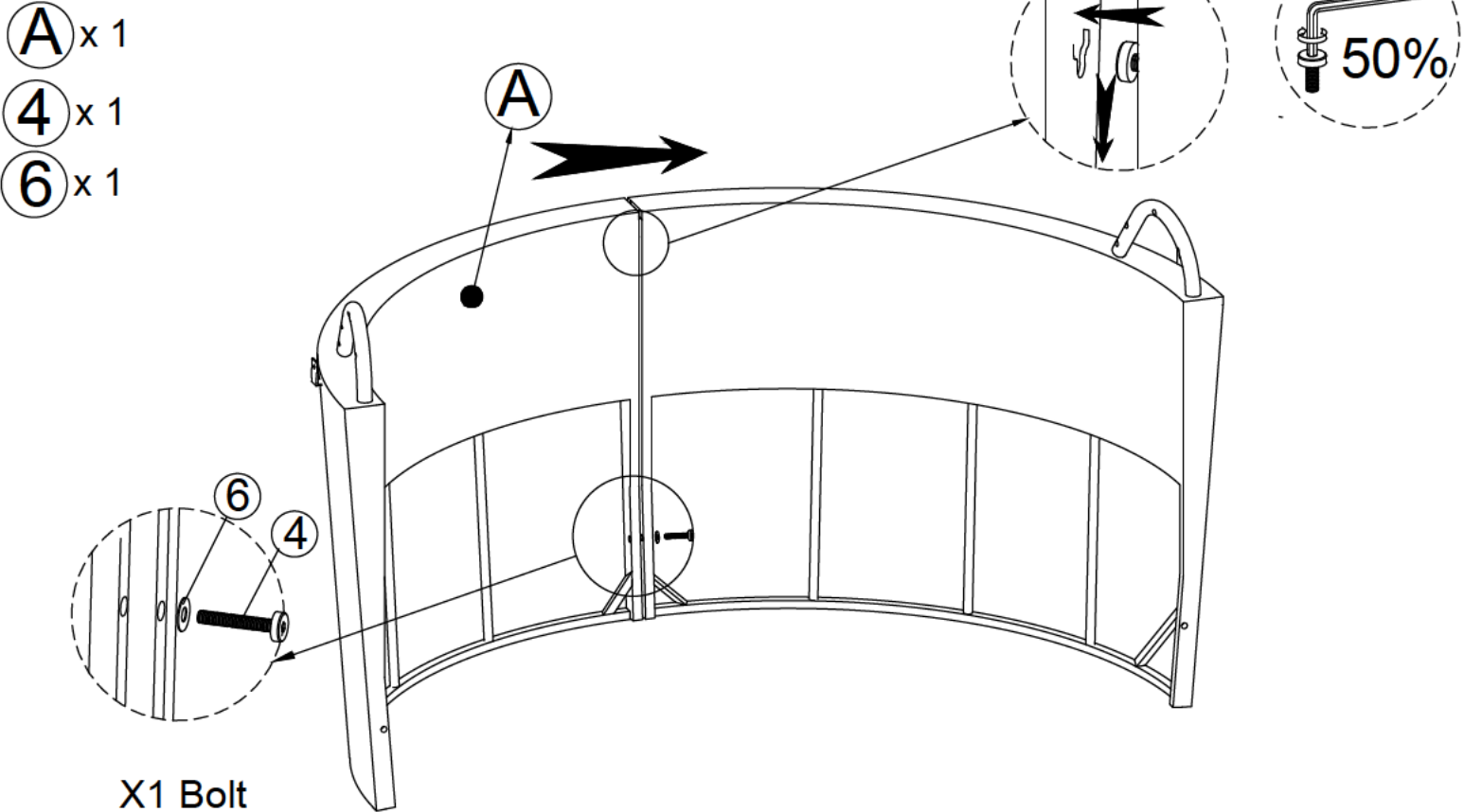

Connect The Part from Step 1 & Back Right (A), tighten Bolt (4), Flat Washer (6) with Allen Key (12).

STEP 3

Q x 1

1 x 4

6 x 4

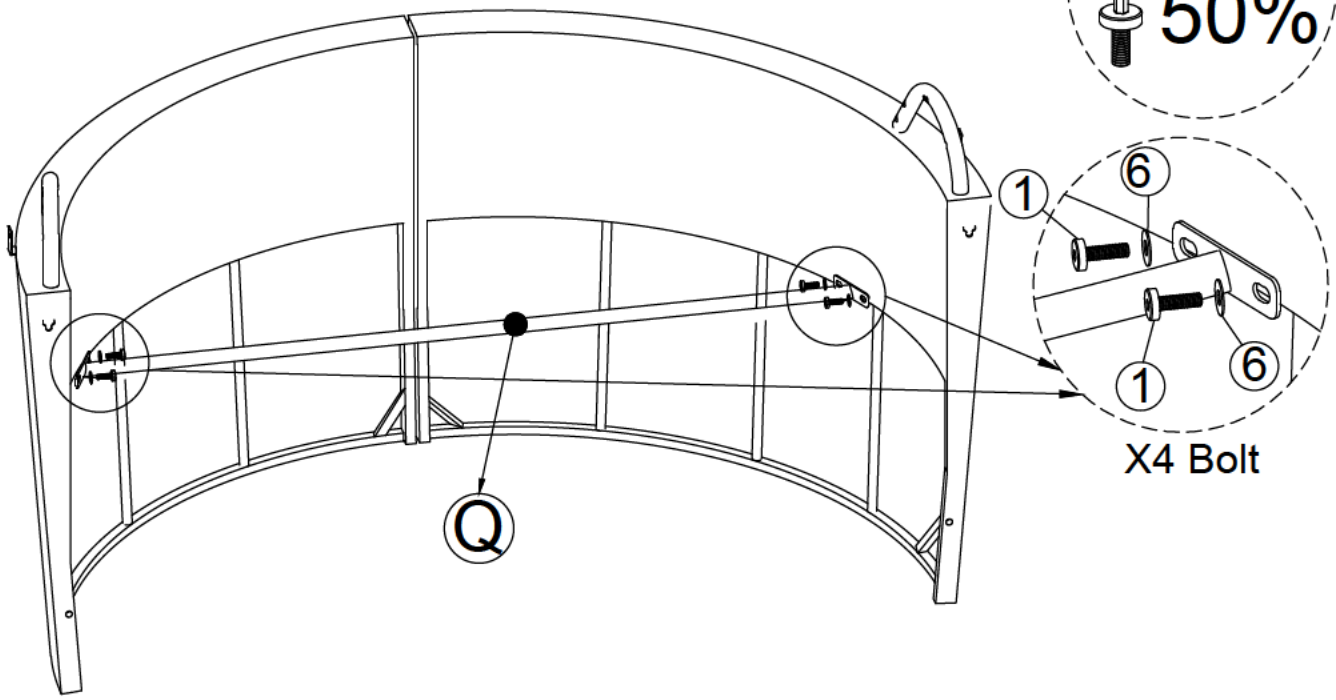

Connect The Part from Step 2 & Support Back (Q), tighten Bolt (1), Flat Washer (6) with Allen Key (12).

STEP 4

G x 1

H x 1

4 x 2

6 x 2

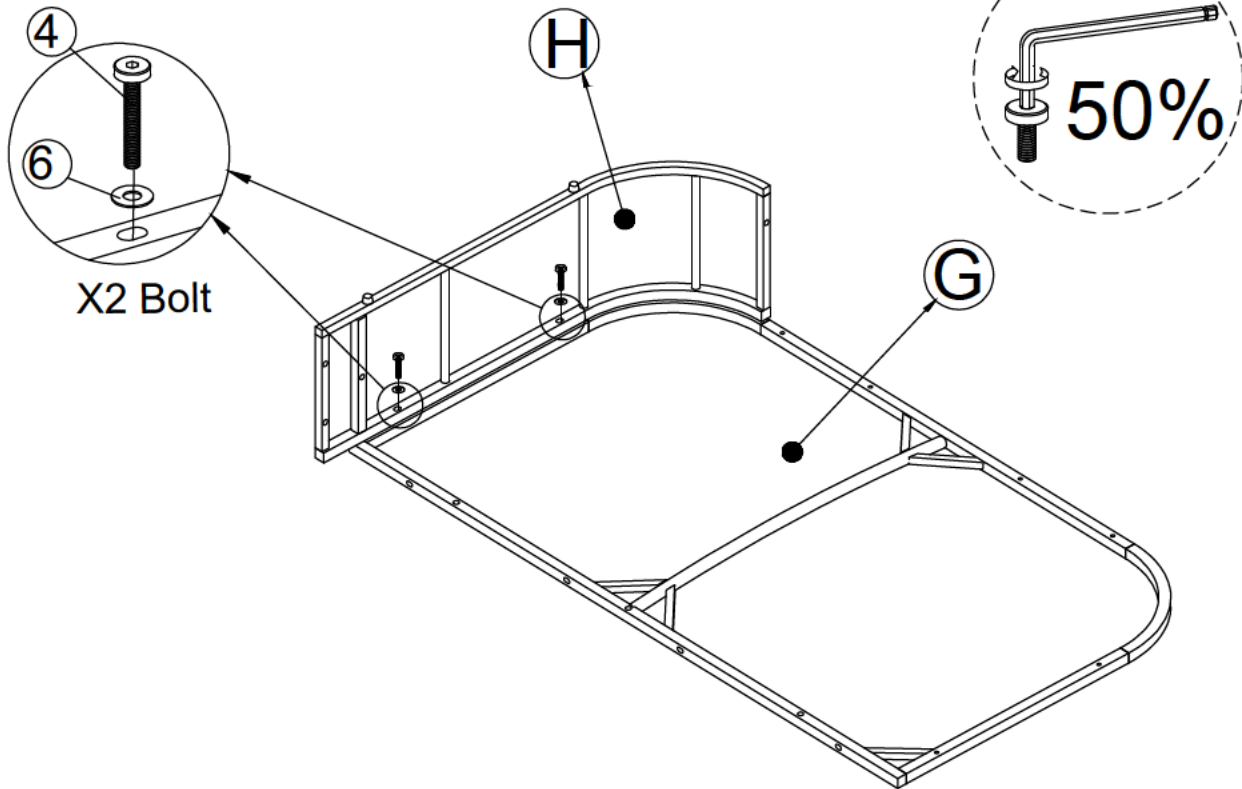

Connect Behind Seat Lounge(G) & Side Right Lounge (H), tighten Bolt (4), Flat Washer (6) with Allen Key (12).

STEP 5

- ① x 1
- ④ x 2
- ⑥ x 2

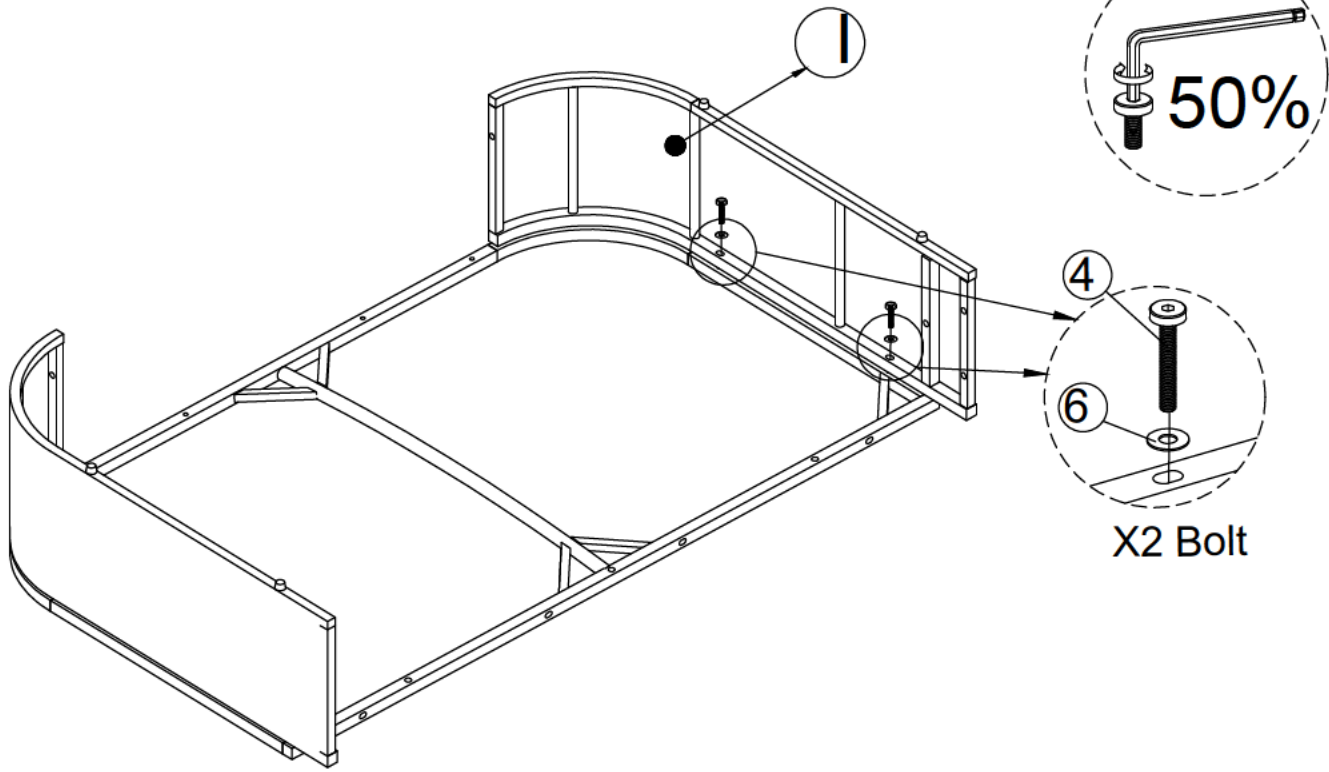

Connect The Part from Step 4 & Side Left Lounge (I), tighten Bolt (4), Flat Washer (6) with Allen Key (12).

STEP 6

- ③ x 1
- ③ x 2
- ④ x 2
- ⑥ x 4

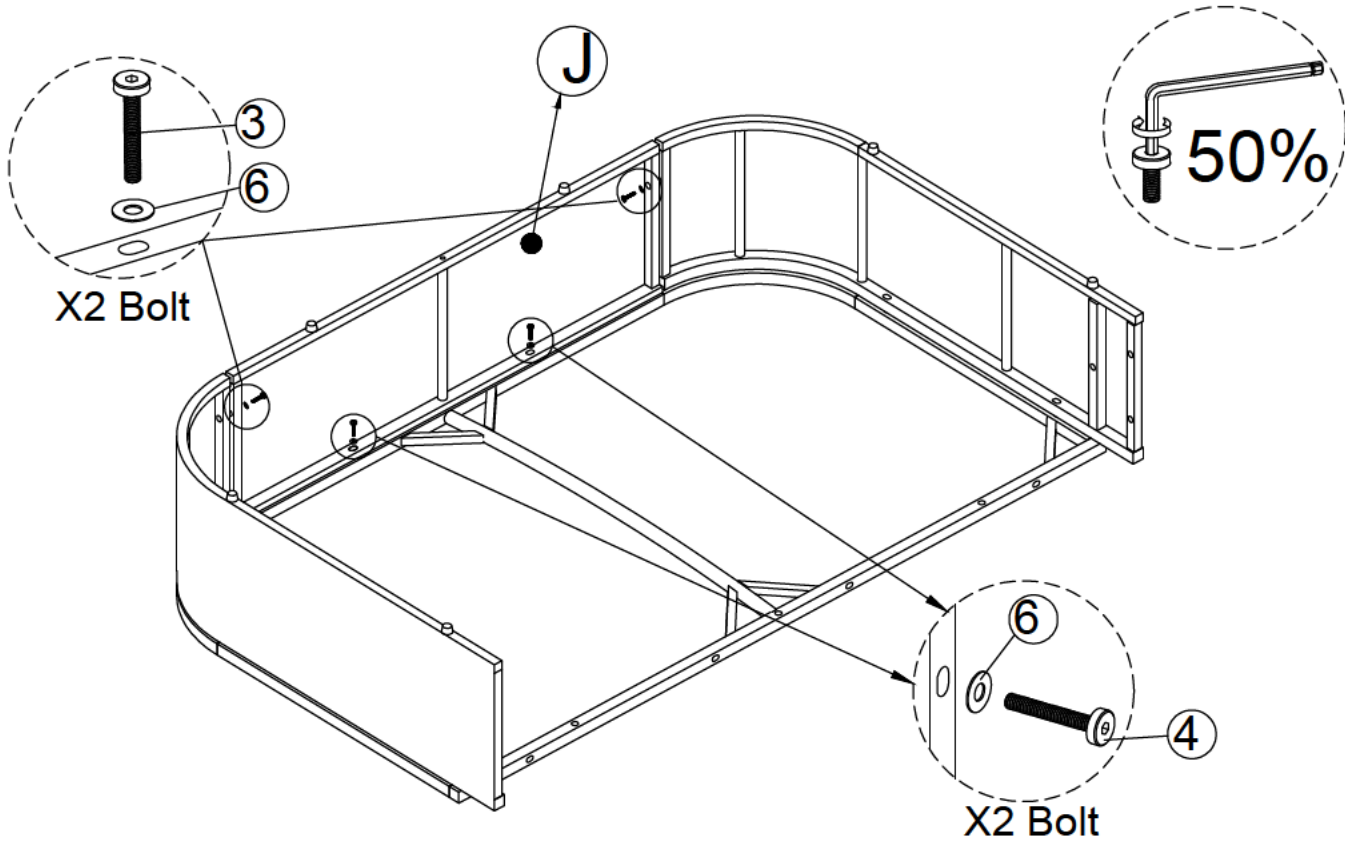

Connect The Part from Step 5 & Front Lounge (J), tighten Bolt (3), Bolt (4), Flat Washer (6) with Allen Key (12).

STEP 7

- L** x 1
- 3** x 2
- 4** x 3
- 6** x 5

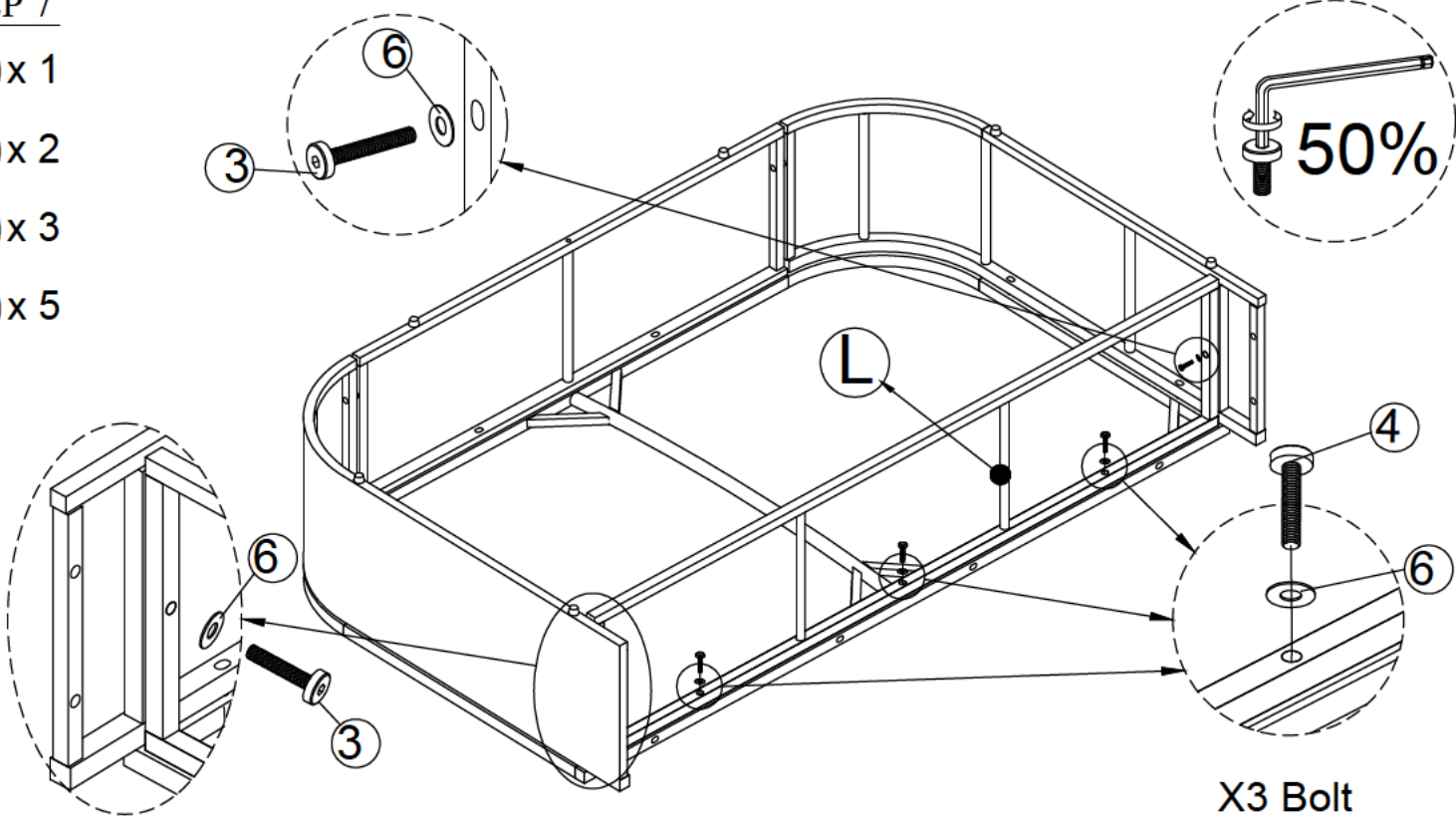

Connect The Part from Step 6 & Middle Bare (L), tighten Bolt (3) Bolt (4), Flat Washer (6) with Allen Key (12).

STEP 8

- F** x 1
- 5** x 4
- 6** x 8
- 9** x 4

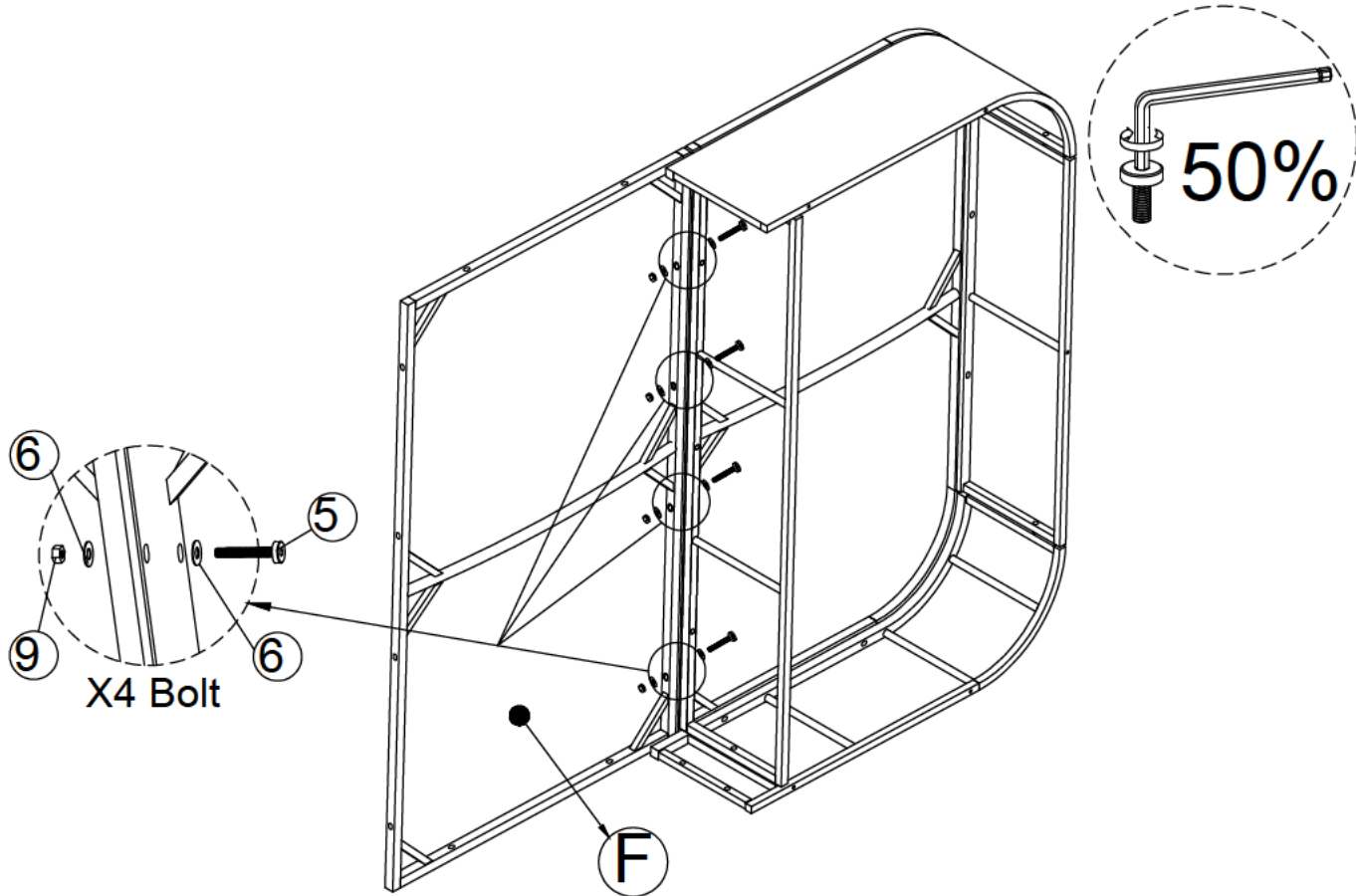

Connect The Part from Step 7 & Middle Seat Lounge (F), tighten Bolt (5), Flat Washer (6), Nut (9) with Allen Key (12), Key (11).

STEP 9

C x 1

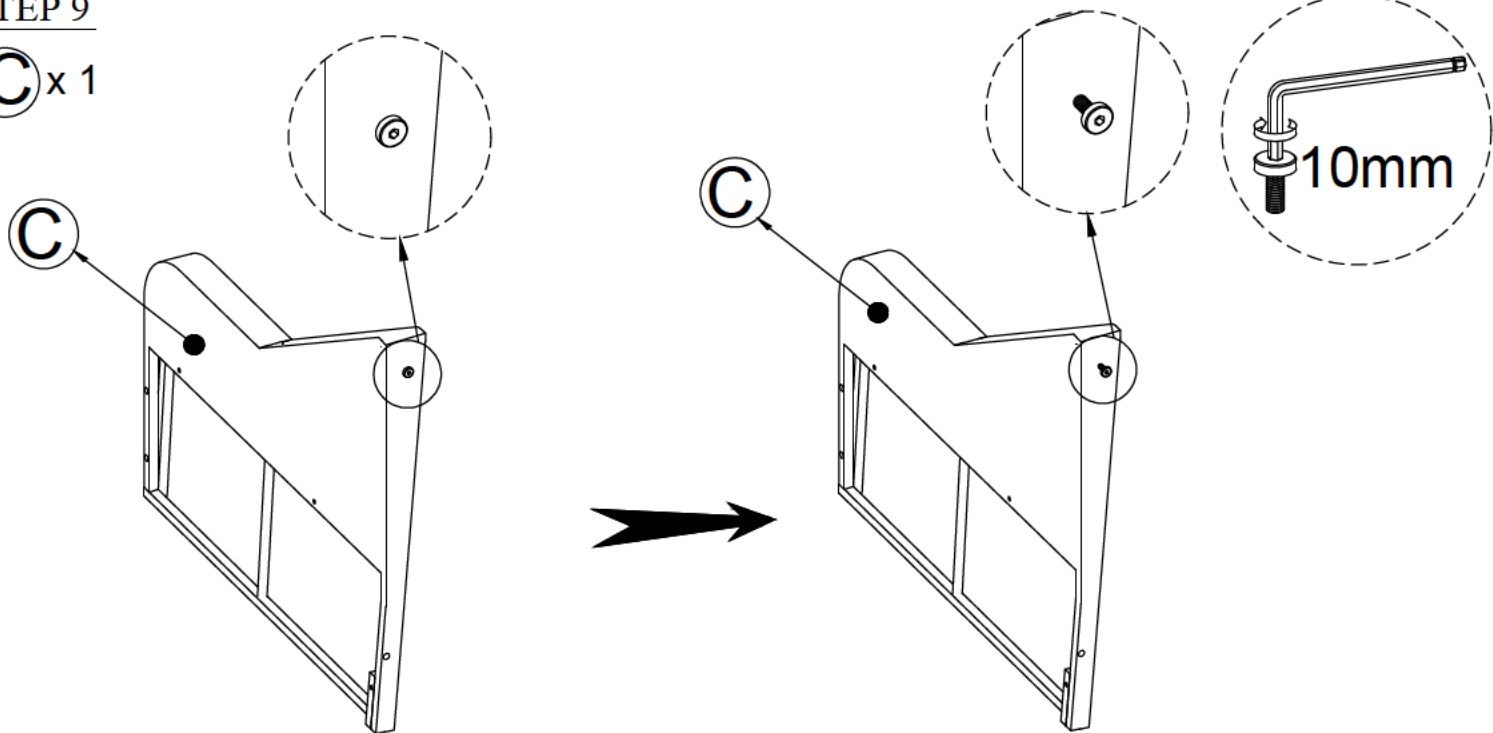

Use Allen key to loosen Bolt on the side of Arm Right (C) about 10 mm.

STEP 10

D x 1

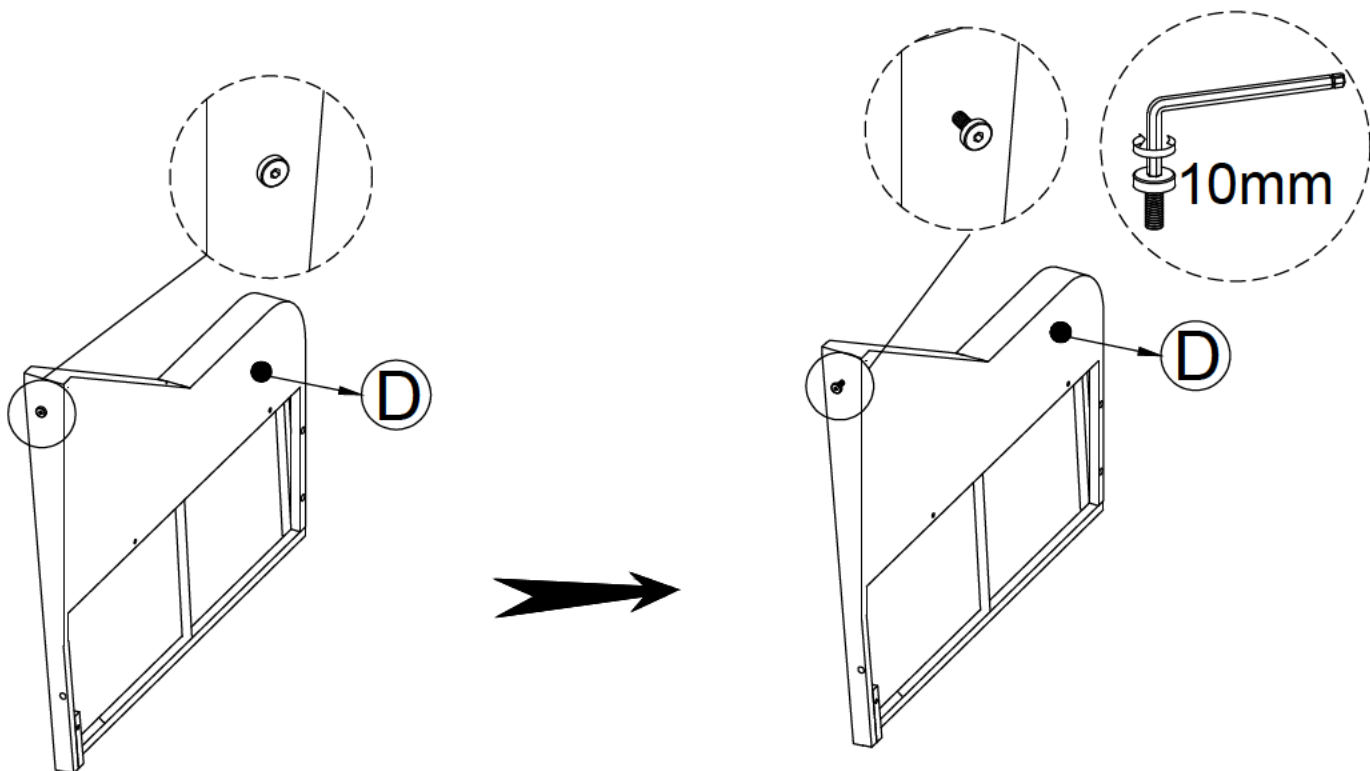

Use Allen key to loosen Bolt on the side of Arm Left (D) about 10 mm.

STEP 11

- D** x 1
- 3** x 2
- 4** x 2
- 6** x 4

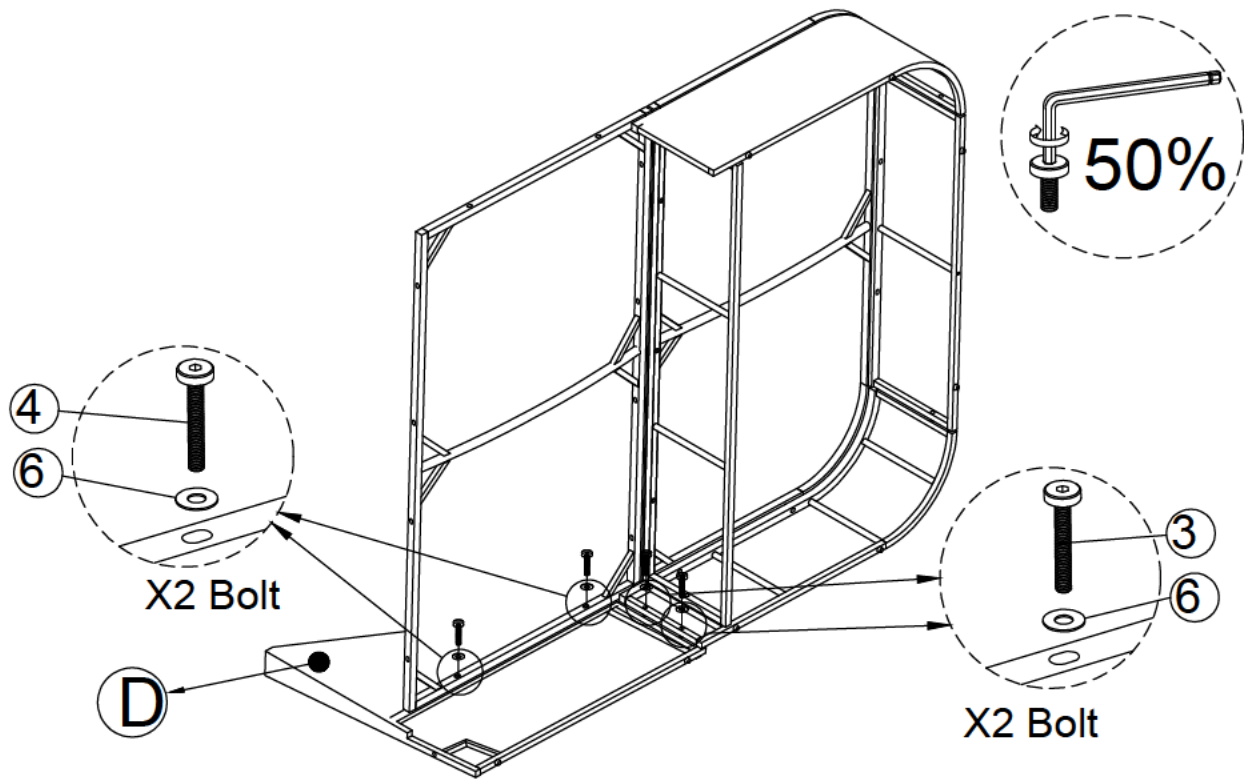

Connect The Part from Step 8 & Part from Step 10, tighten Bolt (3), Bolt (4) Flat Washer (6) with Allen Key (12).

STEP 12

- C** x 1
- 3** x 2
- 4** x 2
- 6** x 4

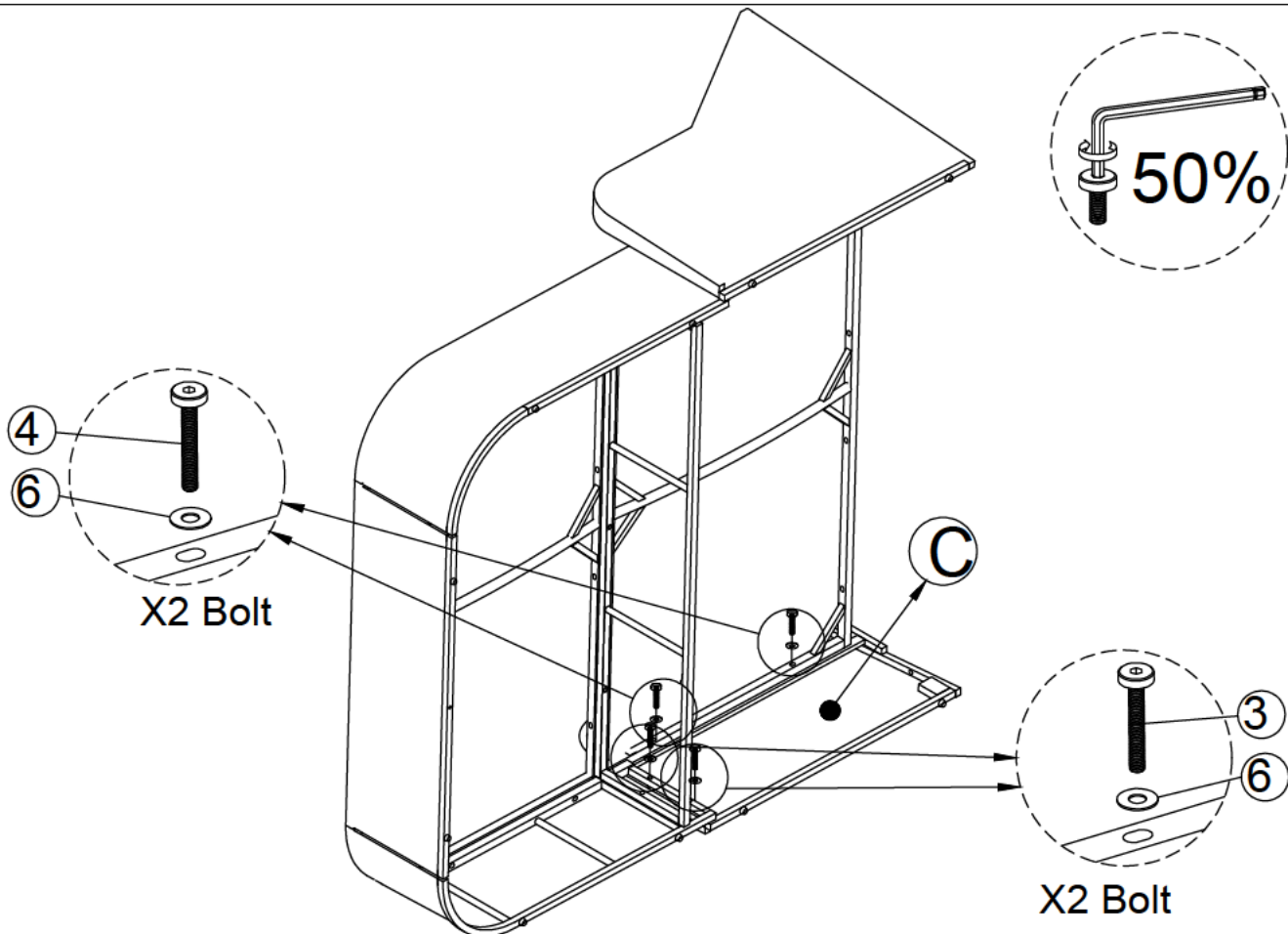

Connect The Part from Step 11 & Part from Step 9, tighten Bolt (3), tighten Bolt (4), Flat Washer (6), with Allen Key (12).

STEP 13

- (E) x 1
- (5) x 4
- (6) x 8
- (9) x 4

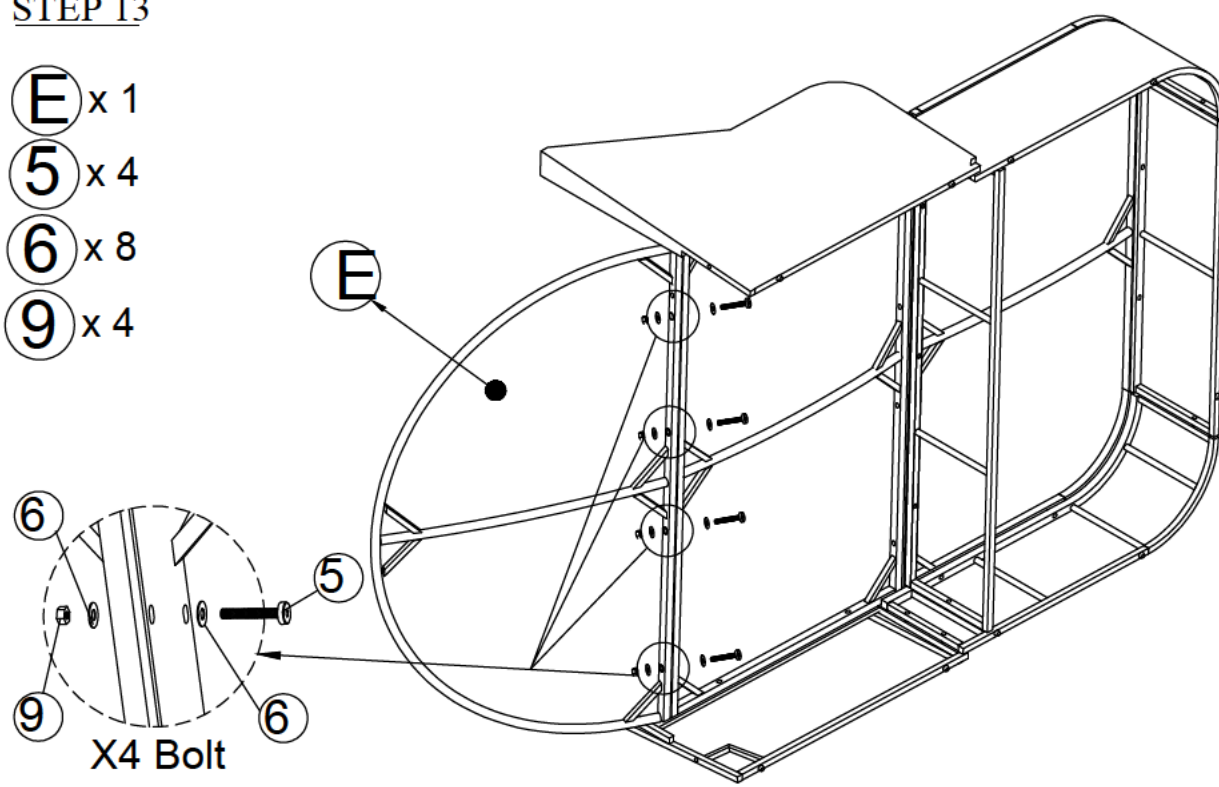

Connect The Part from Step 12 & Front Seat Lounge (E), tighten Bolt (5), Flat Washer (6), nut (9) with Allen Key (12), key (11).

STEP 14

- (K) x 1
- (3) x 2
- (4) x 3
- (6) x 5

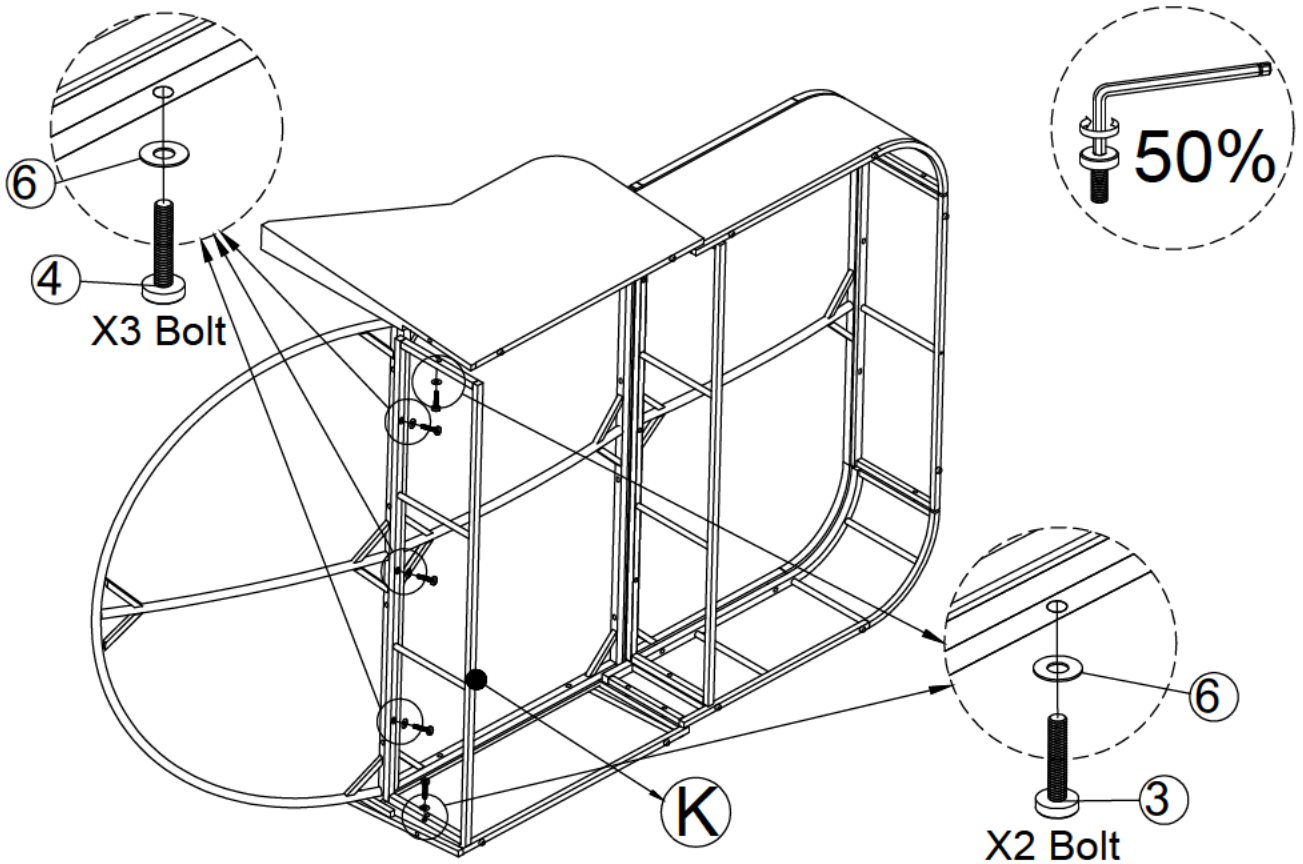

Connect The Part from Step 13 & Front Bare (K) tighten Bolt (3), Bolt (4), Flat Washer (6) with Allen Key (12).

STEP 15

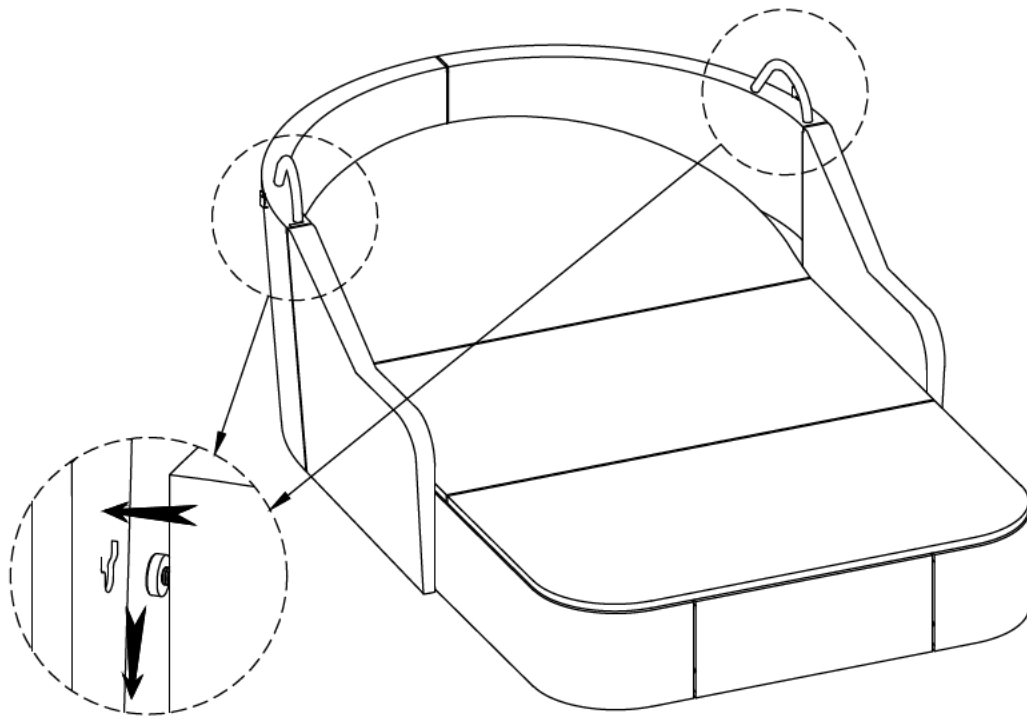

Connect The Part from Step 14 & The Part from Step 3.

STEP 16

④ x 2
⑥ x 2

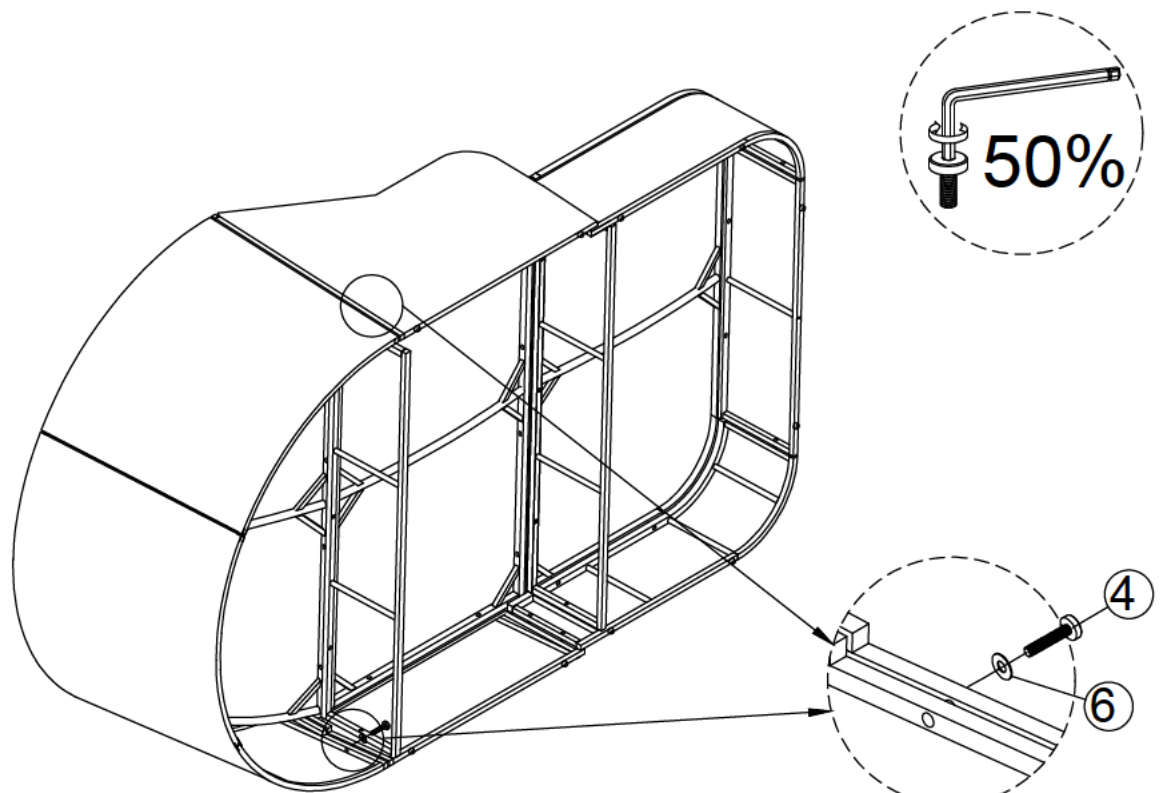

X2 Bolt

Connect The Part from Step 14 & The Part from Step 3, tighten Bolt (4), Flat Washer (6) with Allen Key (12).

STEP 17

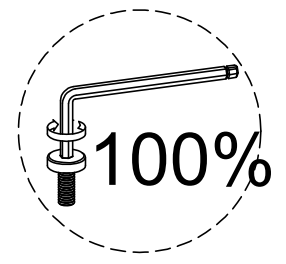
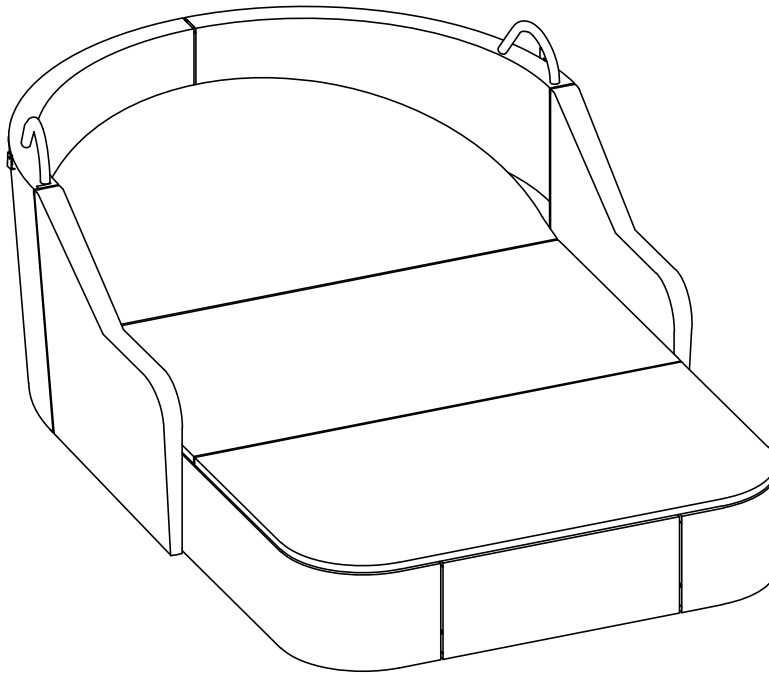

Put the Lounge upright and make sure all legs are level, then firmly tighten Bolts with Allen Key (12), Key (11).

STEP 18

- (M+) x 1
- (M-) x 1
- (N+) x 1
- (N-) x 1
- (O+) x 1
- (O-) x 1
- (P+) x 1
- (P-) x 1
- (14) x 4

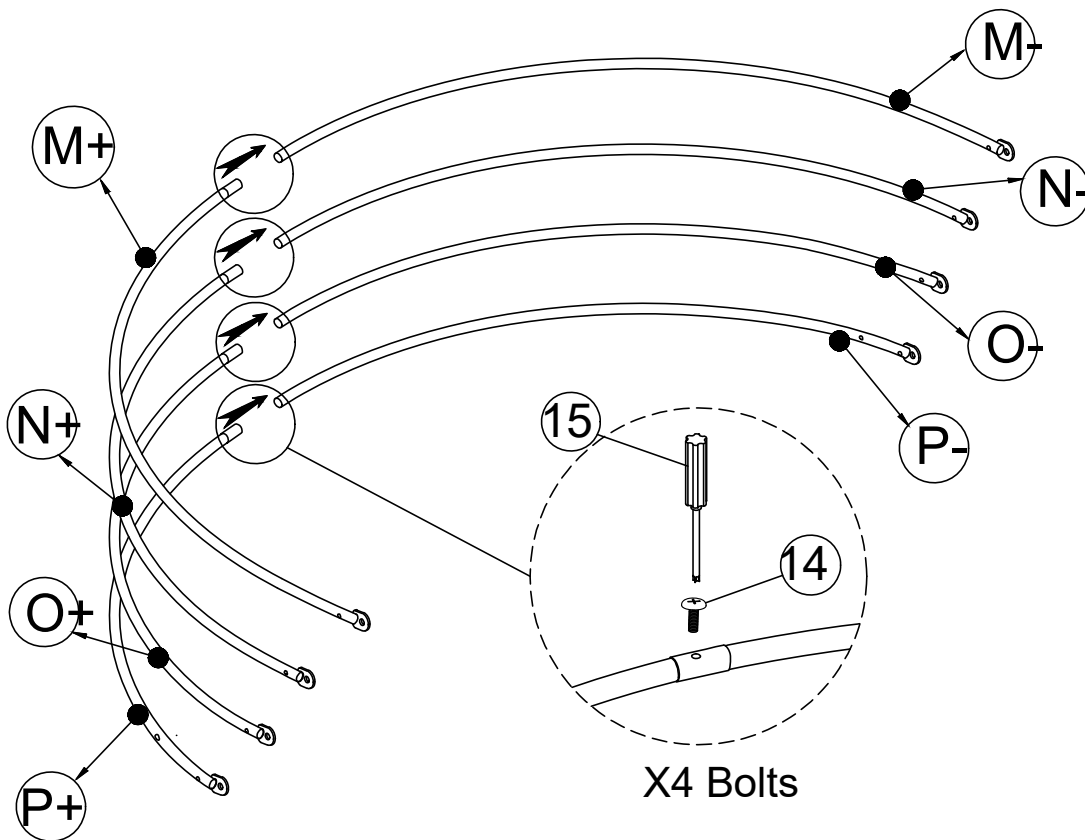

X4 Bolts

Connect The Support M+ & Support M- , Support N+ & Support N- , Support O+ & Support O- , Support P+ & Support P-. tighten Bolts (14) with Screw Driver (15).

STEP 19

(M) x 1

(R) x 1

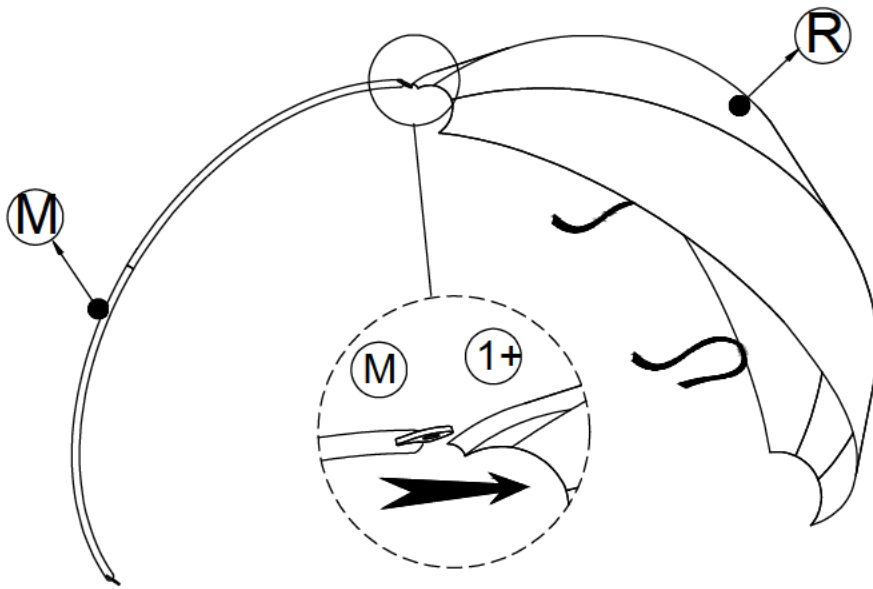

Connect The Support (M) & Covered (R).

STEP 20

(N) x 1

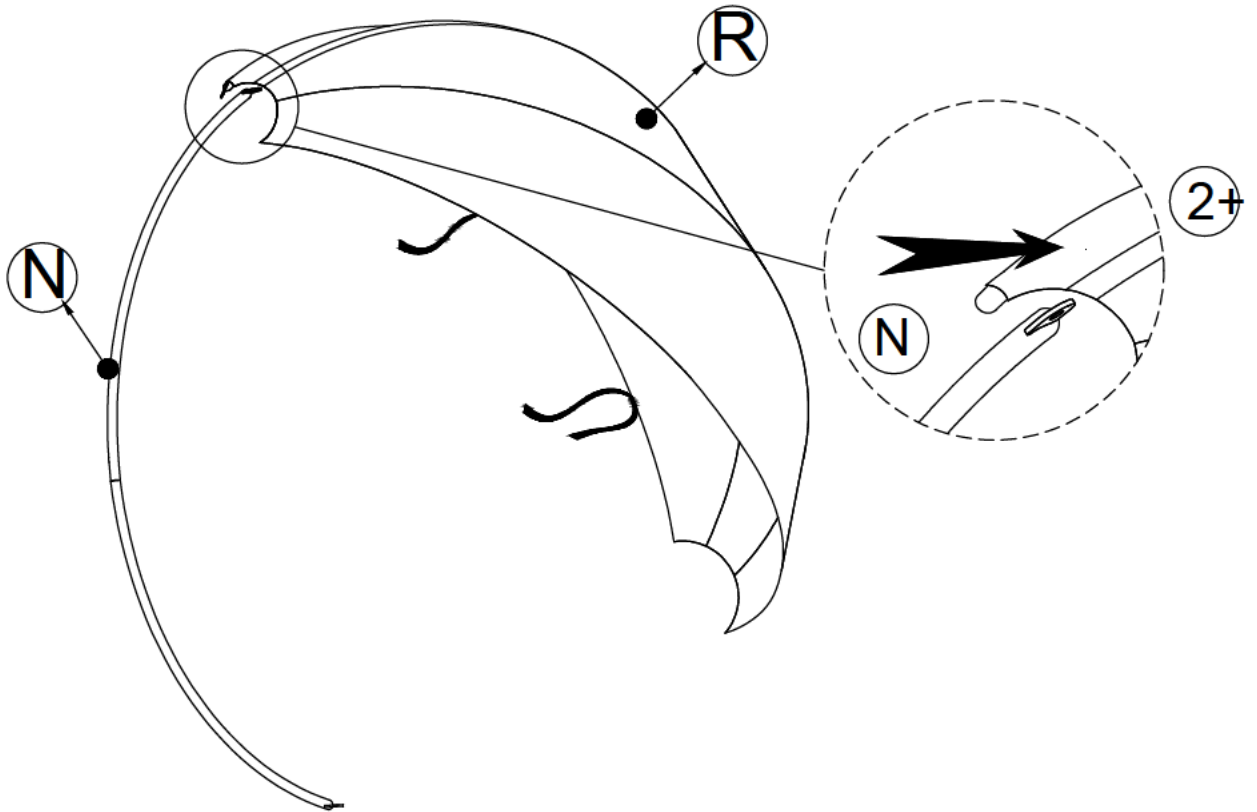

Connect The Part from Step 19 & Support (N)

STEP 21

O x 1

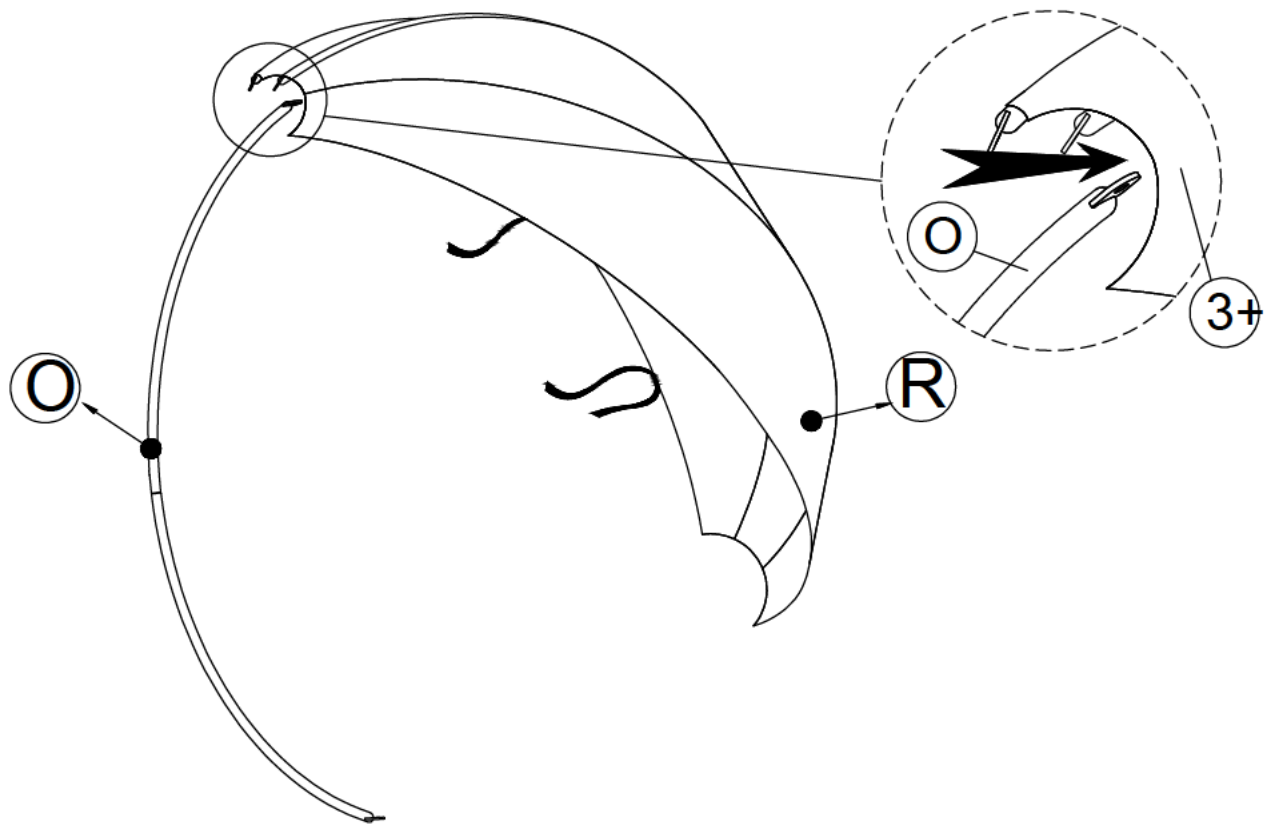

Connect The Part from Step 20 & Support (O)

STEP 22

P x 1

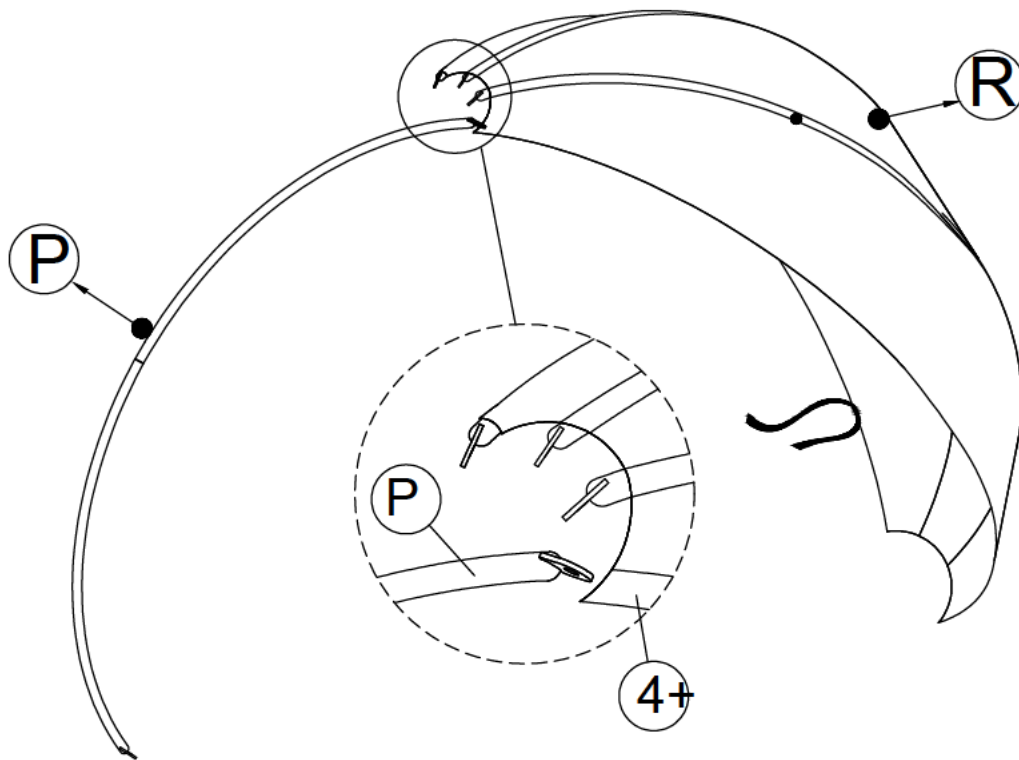

Connect The Part from Step 21 & Support (P)

STEP 23

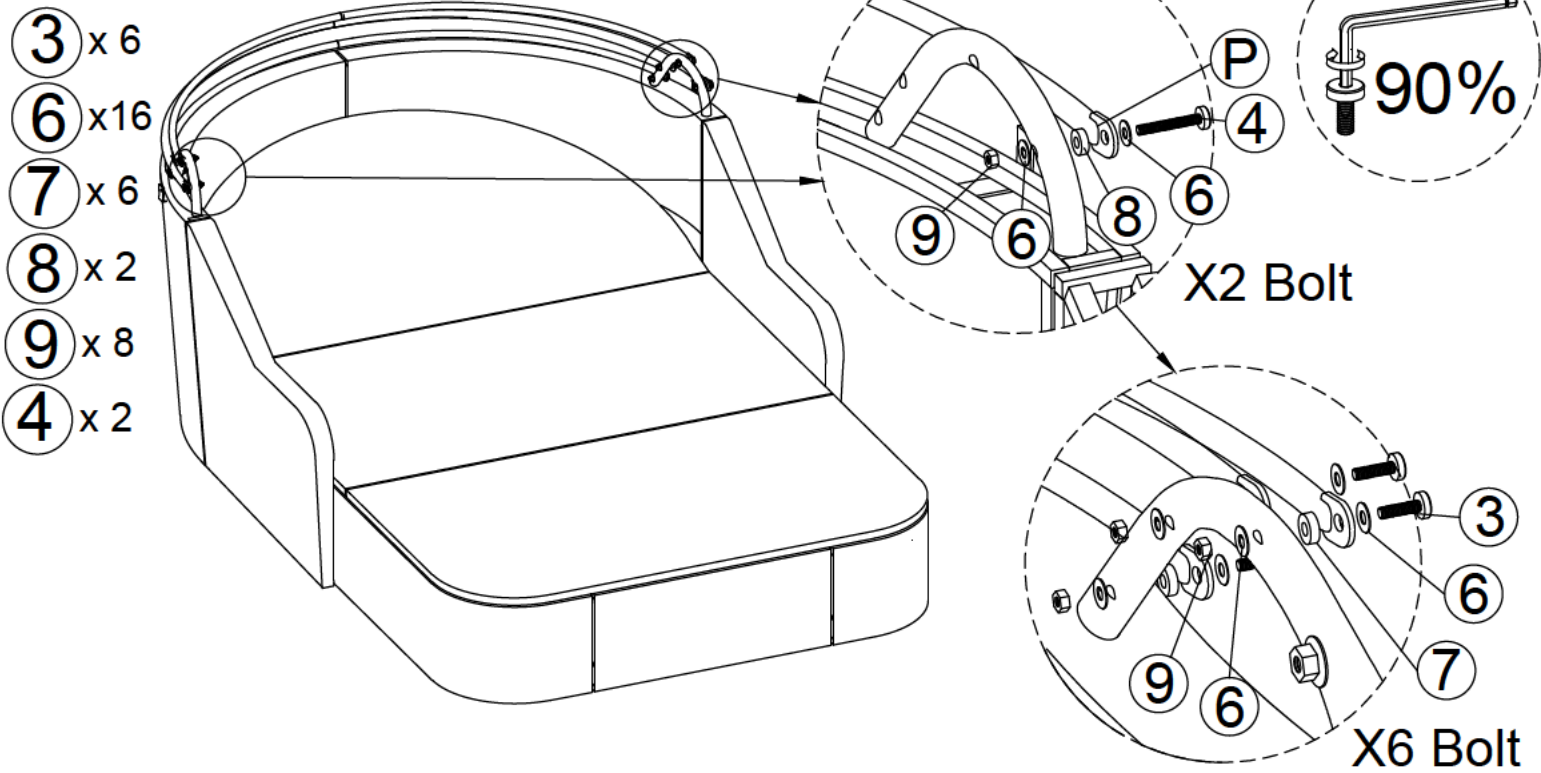

Connect The Part from Step 17 & Step 22, tighten Bolt (4), Bolt (3), Flat Washer (6), Washer (7), Washer (8), Nut (9) with Allen Key (11), Key (12).

STEP 24

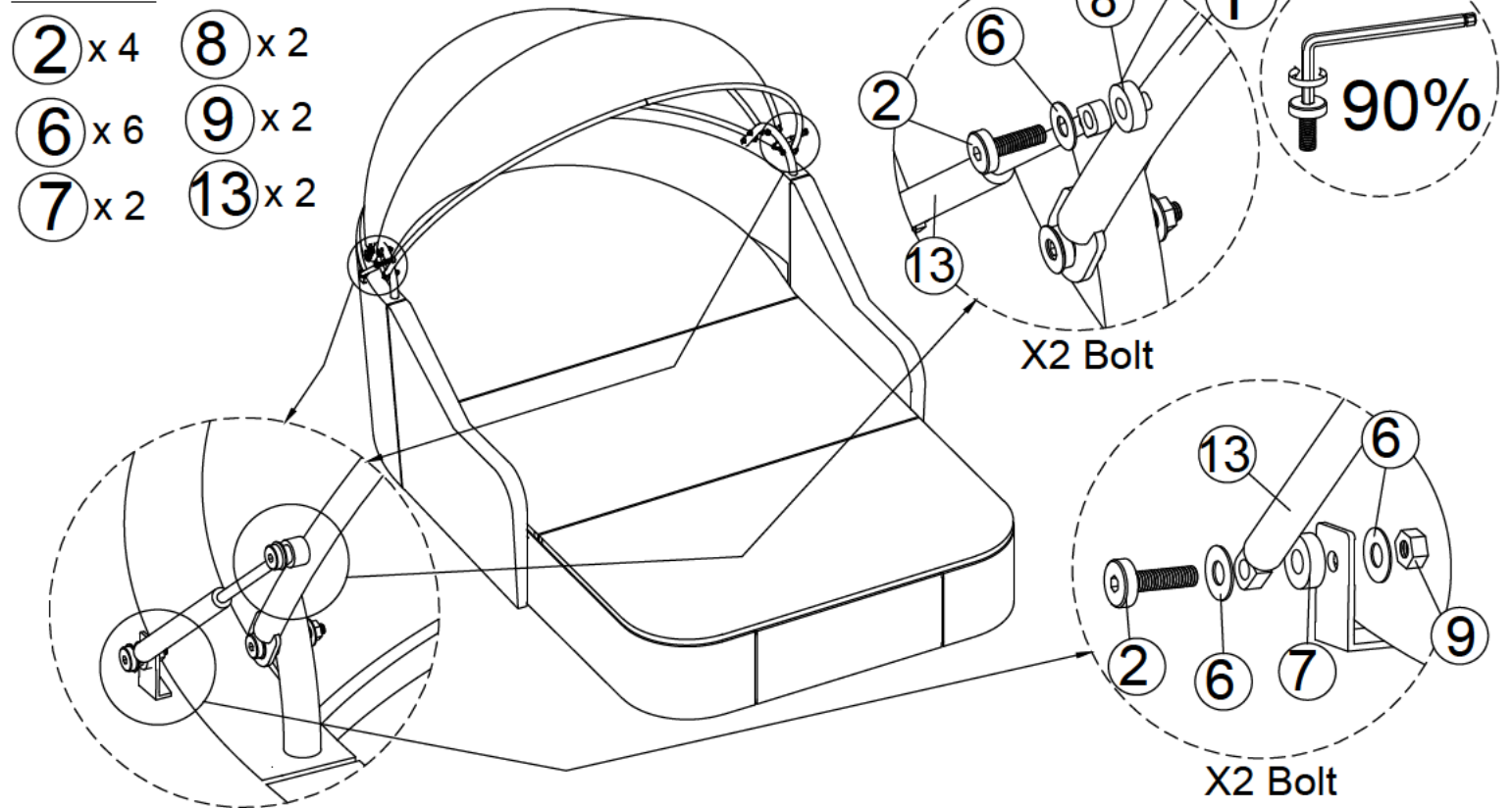

Connect The Part from Step 23 & Gaslift (13), tighten Bolt (2), Flat Washer (6), Washer (7), Washer (8), Nut (9) with Allen Key (12), Key (11).

STEP 25

10 x 10

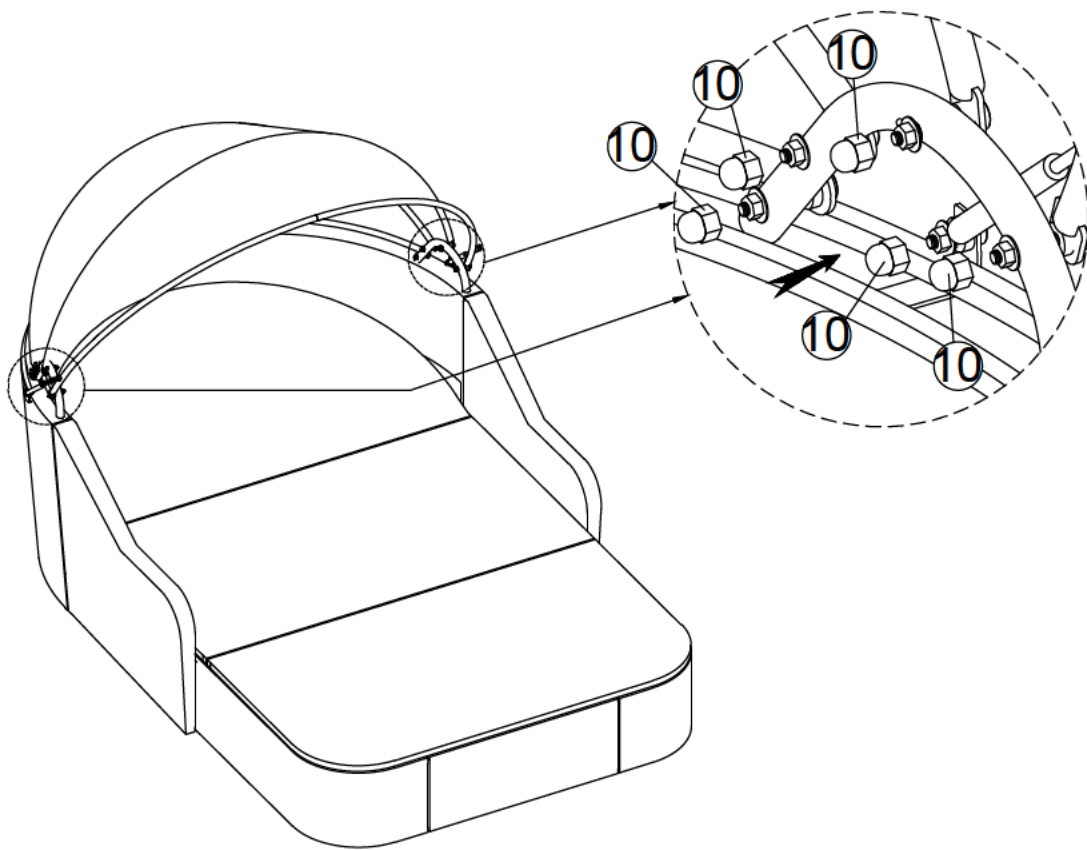

Connect The Part from STEP 24 & Cover Nut (10).

STEP 26

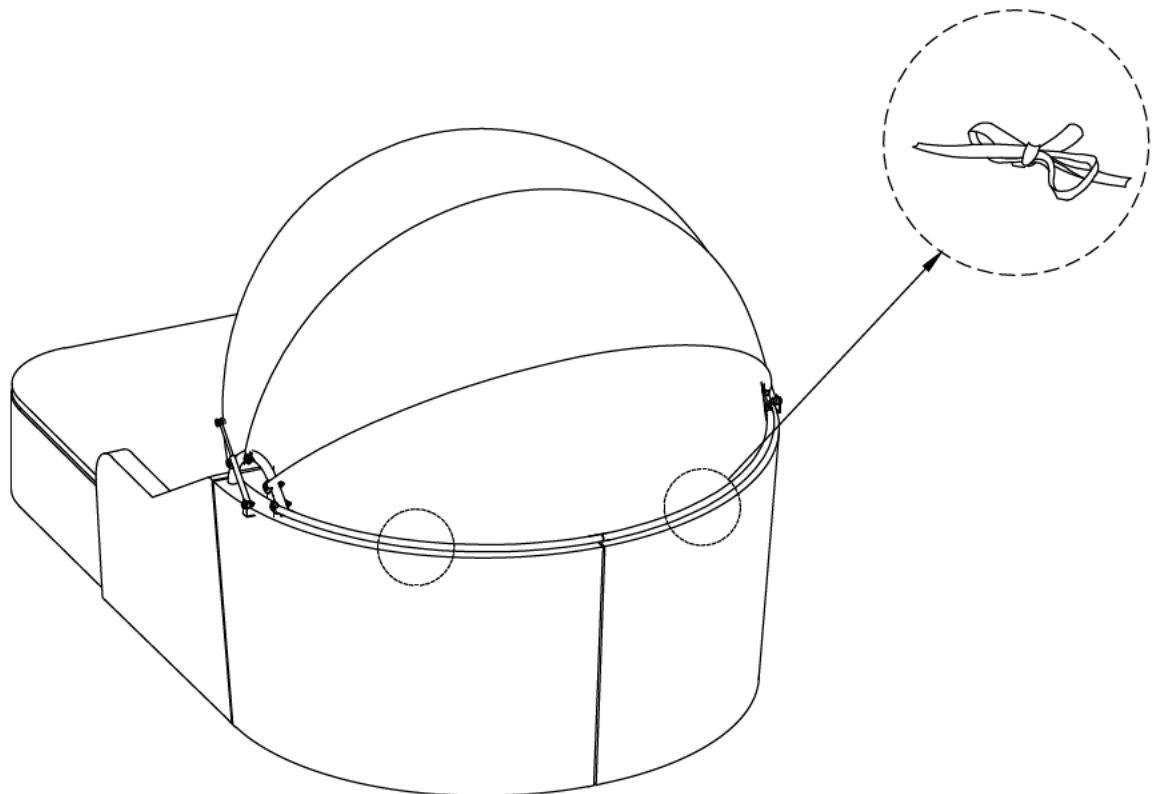

Stick string to Covered to Back Lounge.

STEP 27

⓪ x 1

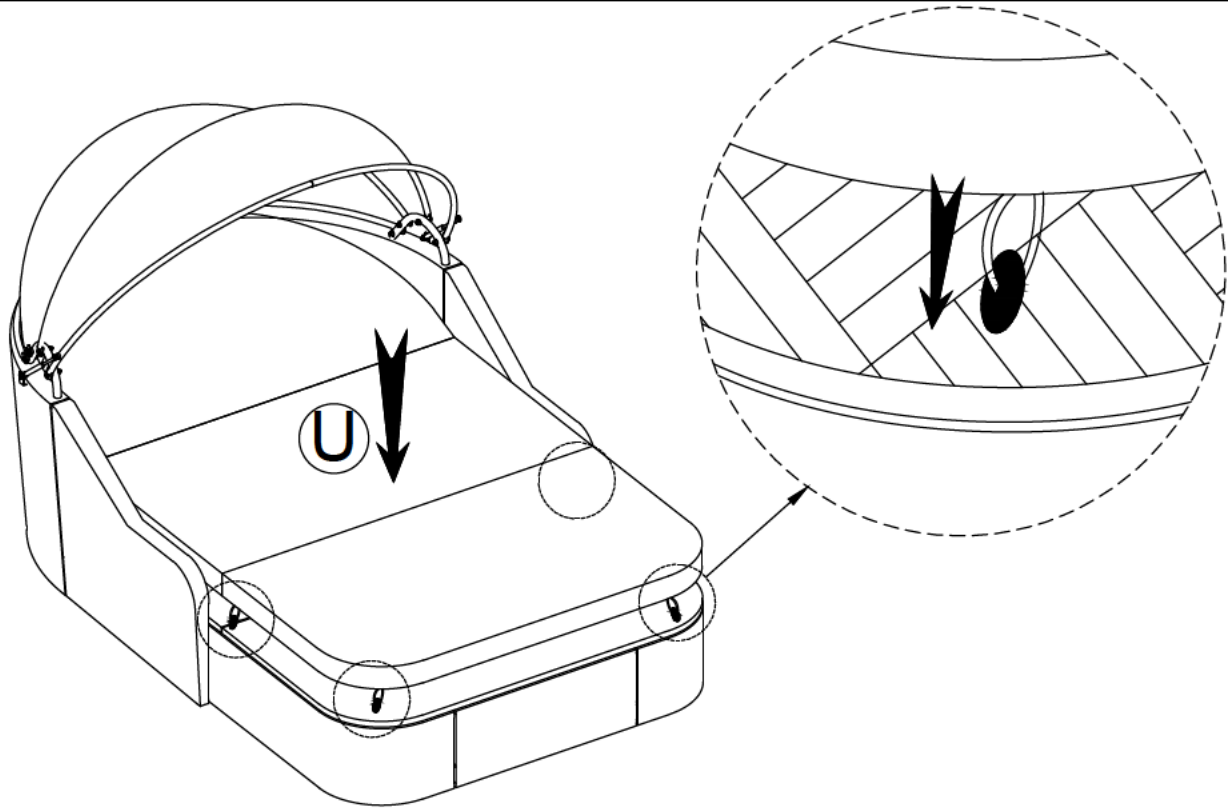

Put on Seat Cushion Right (U) to Lounge.

STEP 28

⓪ x 2

⓪ x 2

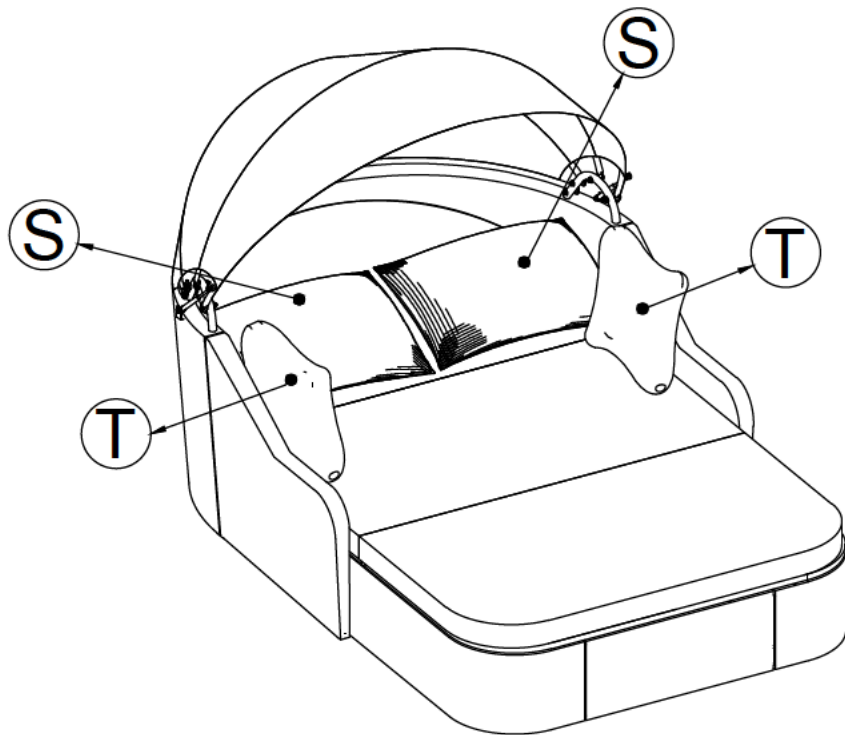

Put on Back Cushion (S) & Pillow Cushion (T) to Lounge.

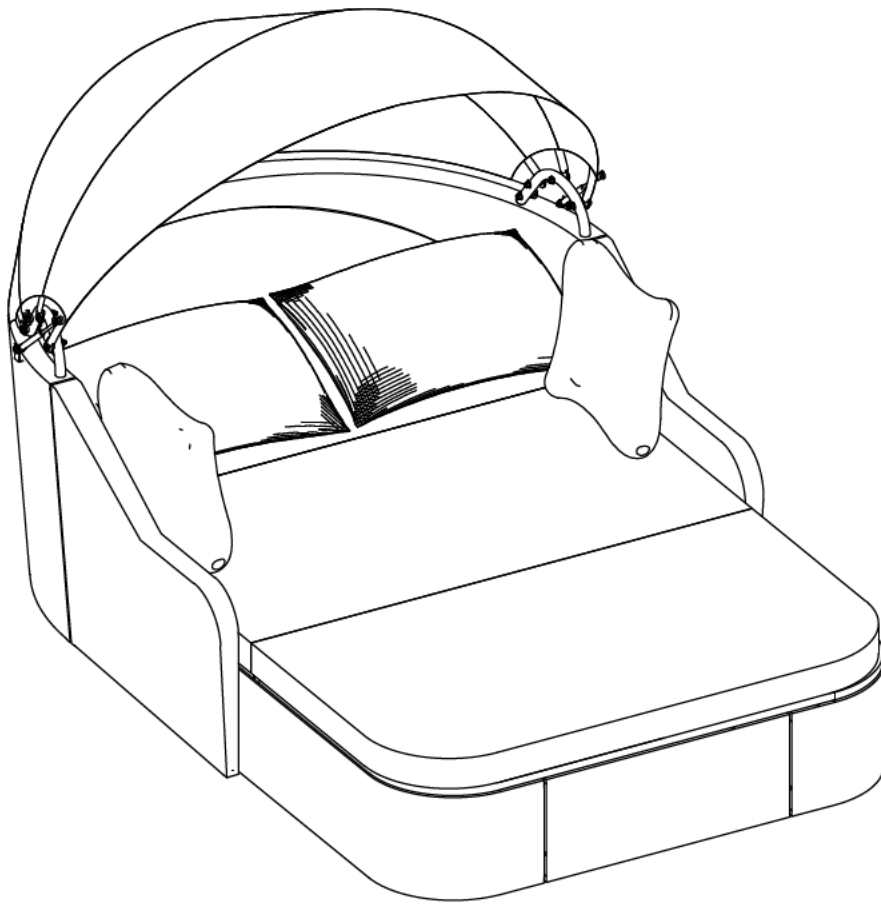

Finish Lounge