



ASSEMBLY INSTRUCTION

Thank you for purchasing this quality product. Be sure to check all packing material carefully for small parts which may come loose inside the carton during shipment.

Identify and count all parts.

NOTE: ASSEMBLE THE CHAIR ON A FLAT & SOFT SURFACE. DO NOT TIGHTEN ALL THE SCREWS UNTIL THE CHAIR HAS BEEN PUT A FLAT /HARD SURFACE ADJUST & LEVEL ALL THE LEGS SO THAT THEY DO NOT WOBBLE. ONCE ADJUSTED THEN TIGHTEN ALL THE SCREWS.

PARTS LIST		
NO	DESCRIPTION	QTY
1	CUSHION SEAT WITH FRAME	1
2	BENCH LEG - LEFT	2
3	BENCH LEG - RIGHT	2
4	SUPPORT RAIL	2
5	LOWER RAIL	2

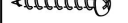
HARDWARE LIST		
NO	DESCRIPTION	QTY
A	 JCBC SCREW M6 x 40MM WITH LOCK WASHER & WASHER	4
B	 JCBC SCREW M6 x 60MM WITH LOCK WASHER & WASHER	8
C	 ALLEN KEY M4	1
D	 P.H SCREW #8 x 32MM	4

STEP 1

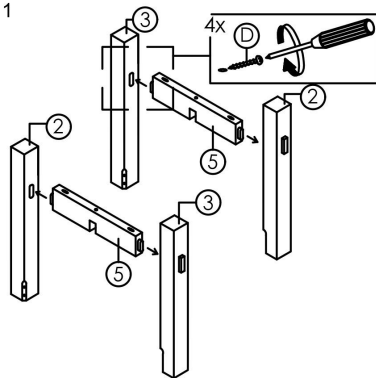

STEP 2

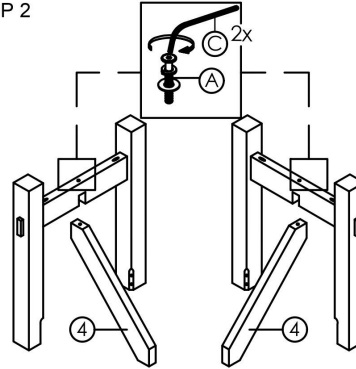

STEP 3

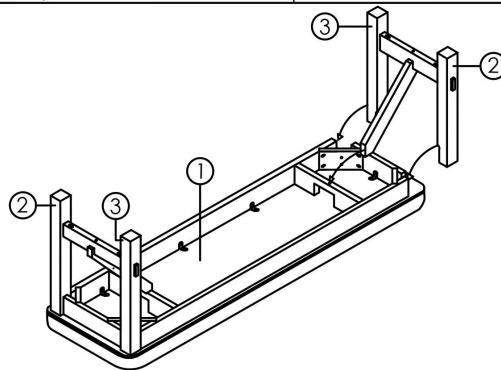

NOTE: TO ENSURE CHAIR DURABLE AND LONG LASTING, PLEASE CHECK ENTIRE CHAIR PART WHETHER IT'S IN SAFE AND ORDINARY CONDITIONS.

STEP 4

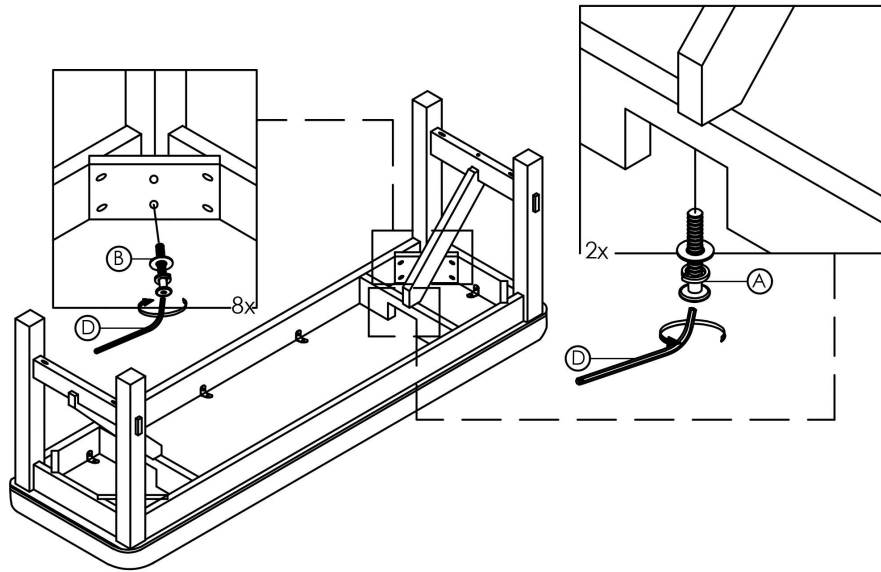

STEP 5

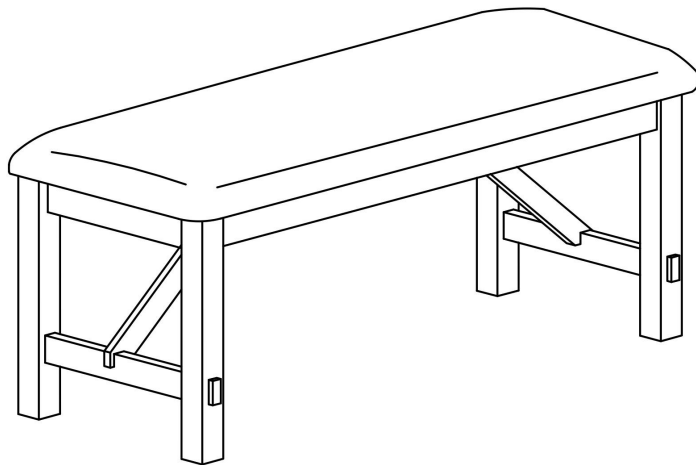

NOTE: TO ENSURE CHAIR DURABLE AND LONG LASTING, PLEASE CHECK ENTIRE CHAIR PART WHETHER ITS IN SAFE AND ORDINARY CONDITIONS.