

28

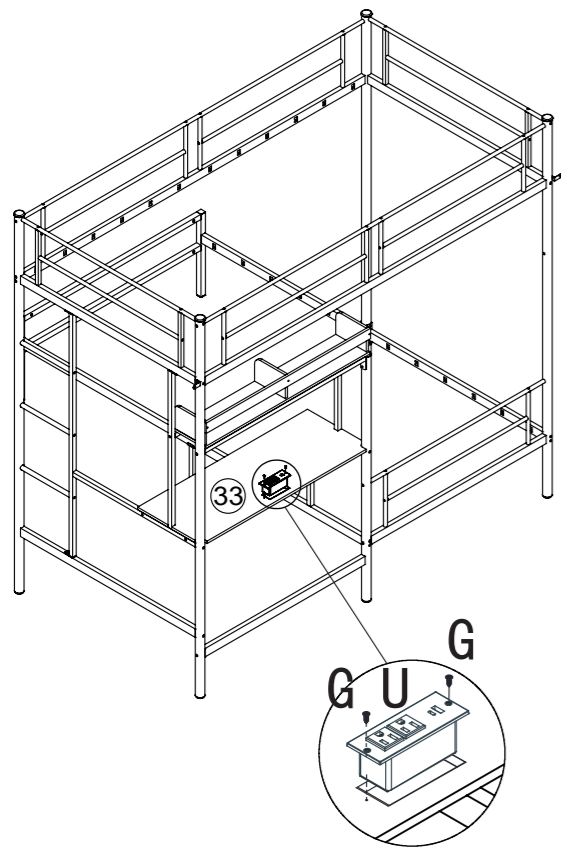

G		2pcs
	ST4x14	

29

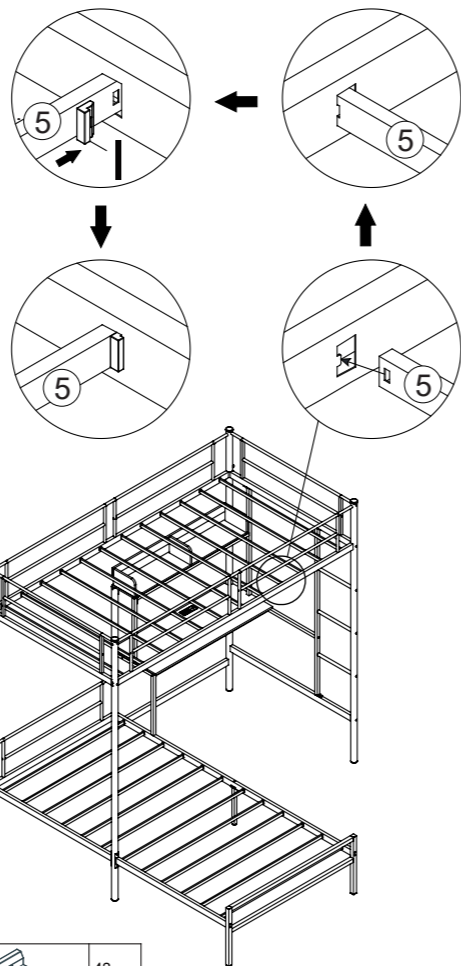

I		48pcs
---	---	-------

30

- 1: Using a drill bit with a diameter of 6, drill mounting holes where installation is required
- 2: Place the expansion tube into the hole
- 3: Screw the screw together with the mounting part into the expansion pipe

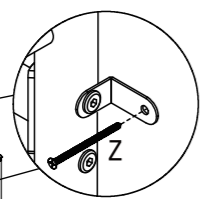

Z		2pcs
---	---	------

Finish

31

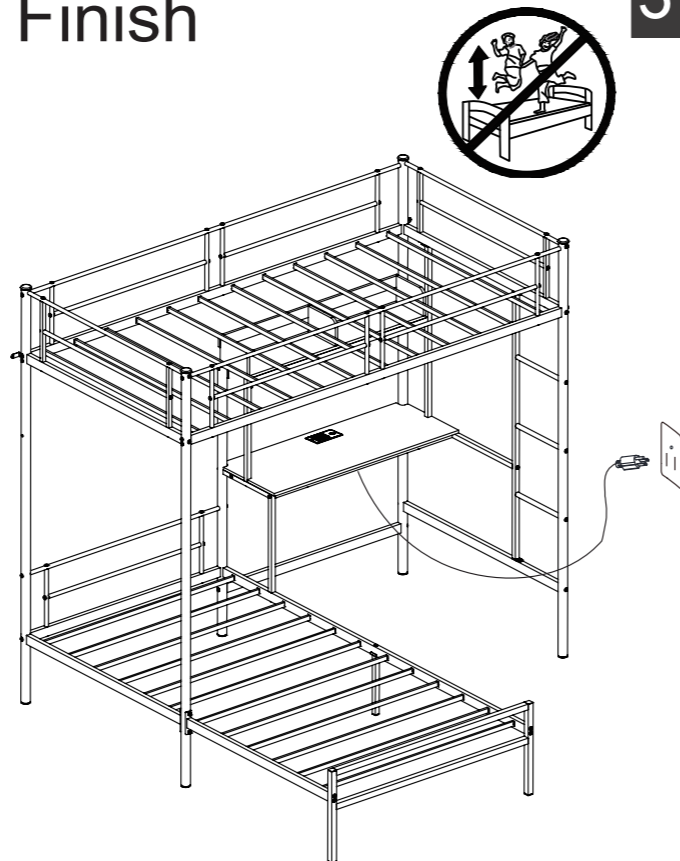

Note: Now you can tighten all the bolts.

BED FRAME

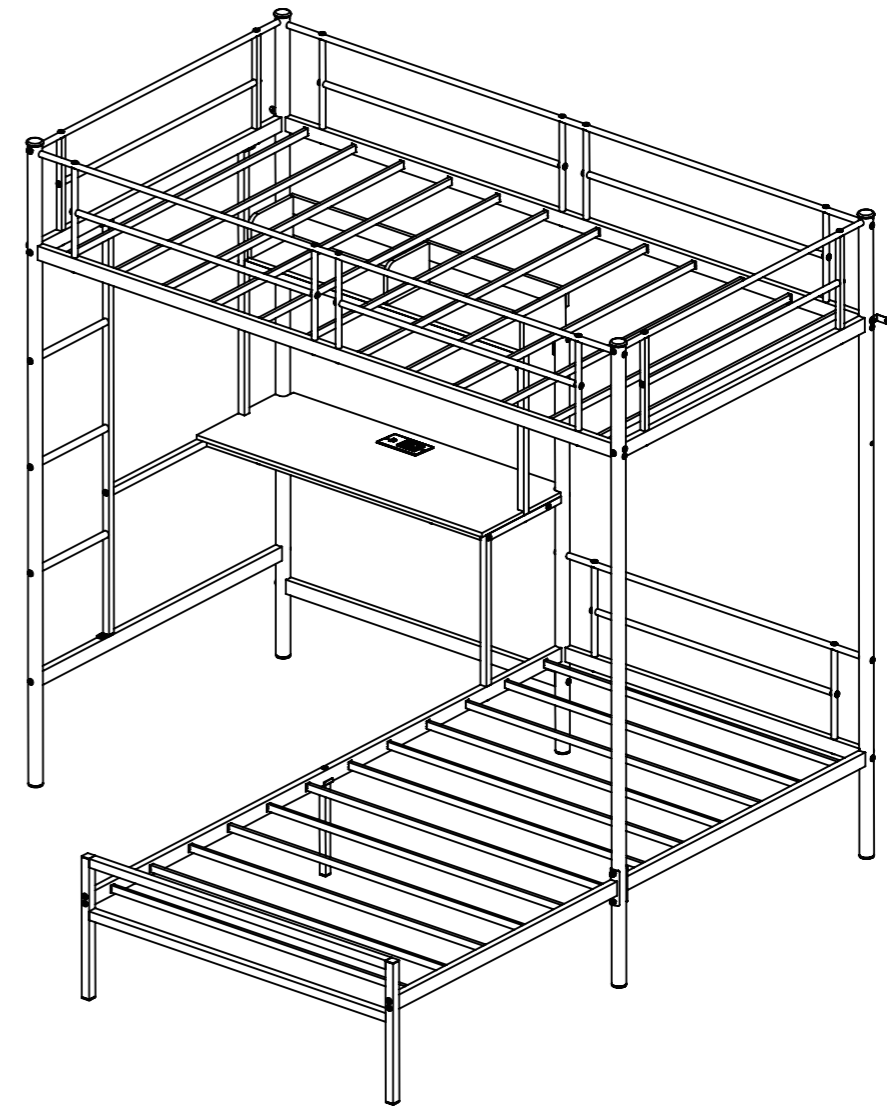

Thank you for choosing our products, please assemble and use it following the instructions.

Assembly Instruction

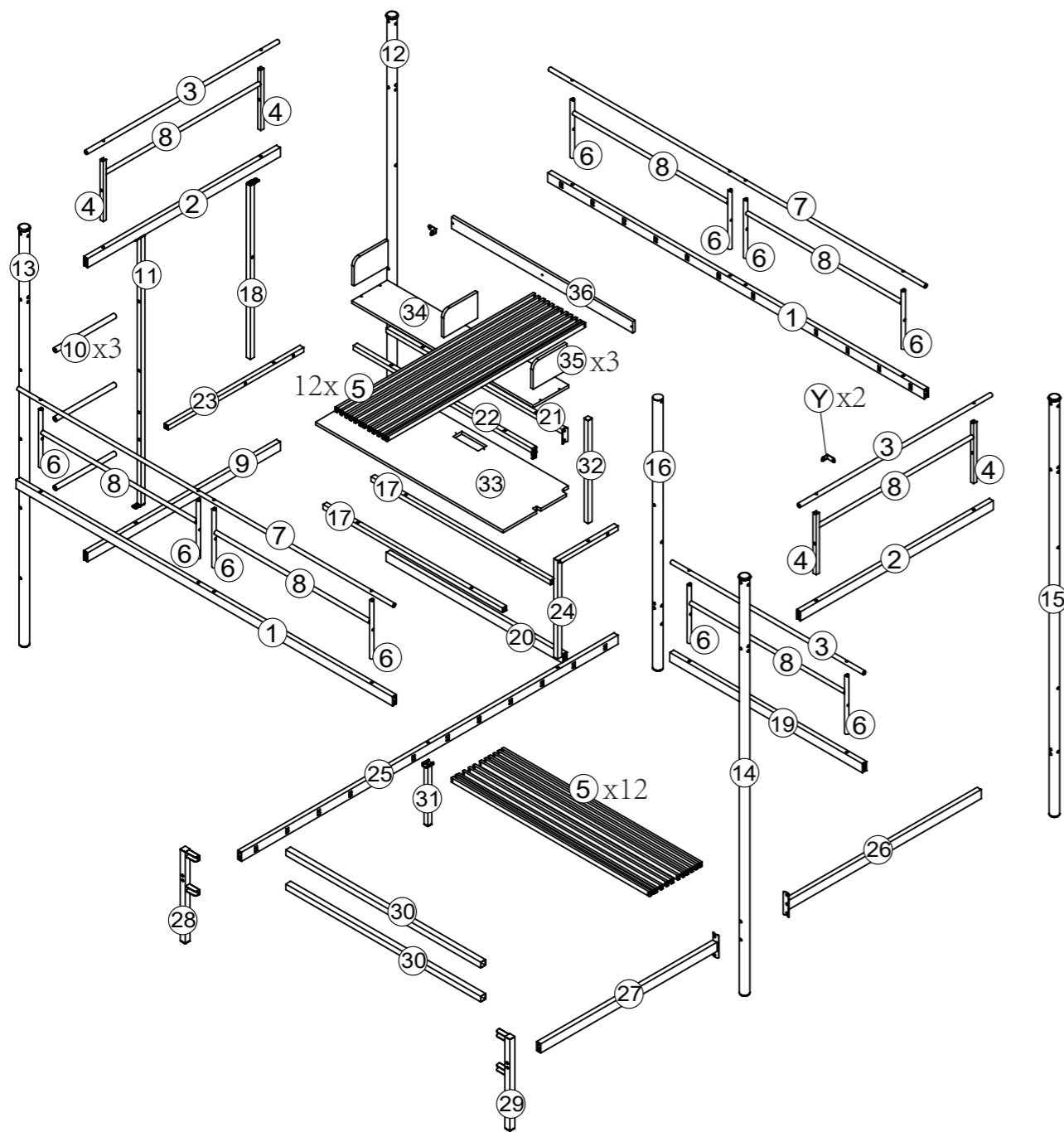

B438

Important Note

HARDWARE NOTE :

1. Two or more people are required for assembly
2. Do not screw on the bolts too tight unless the installation is done. Make sure all bolts are tightly screwed before you use it.

24

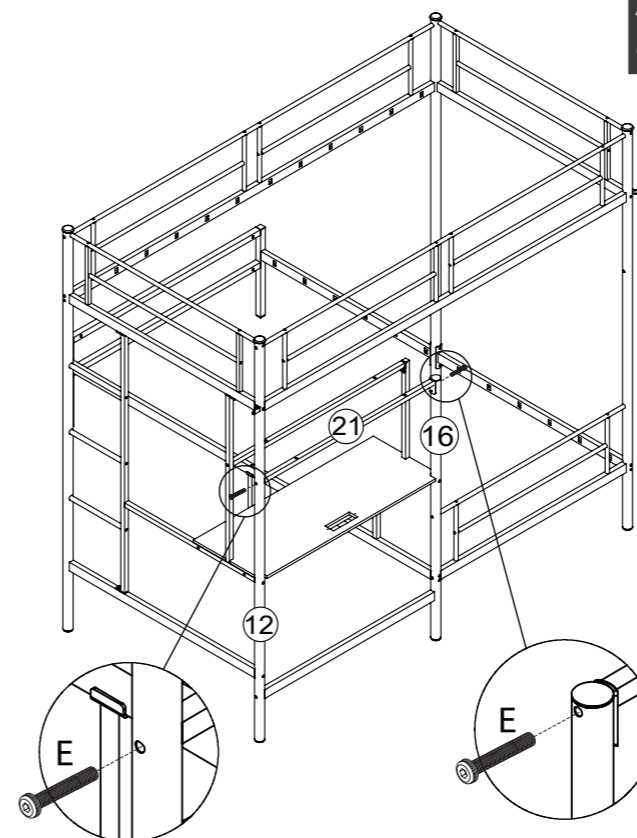

E  2pcs

! Do not fully tighten the screws yet.

25

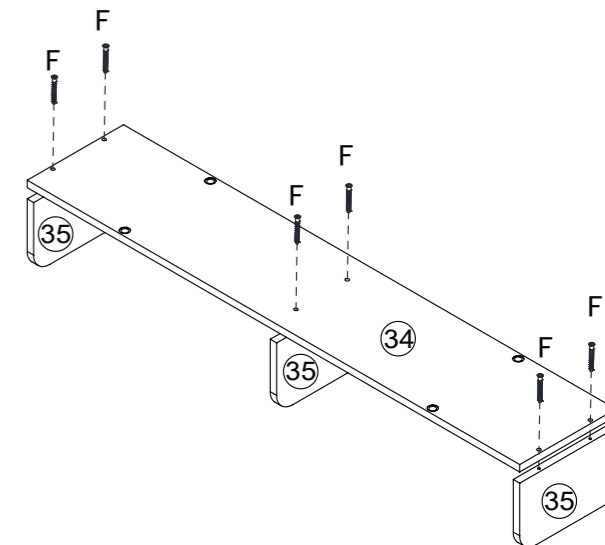

F  6pcs

26

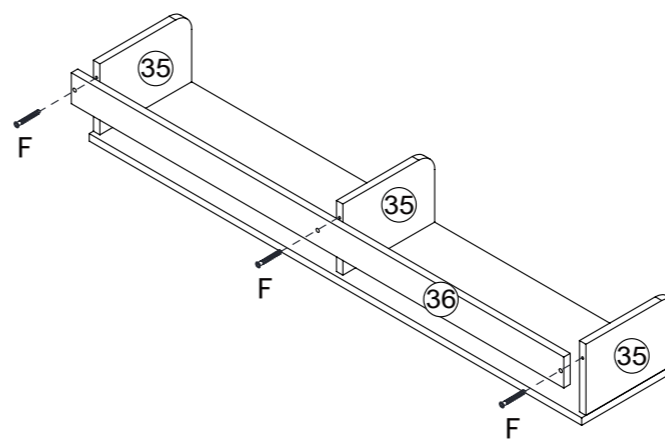

F  3pcs

27

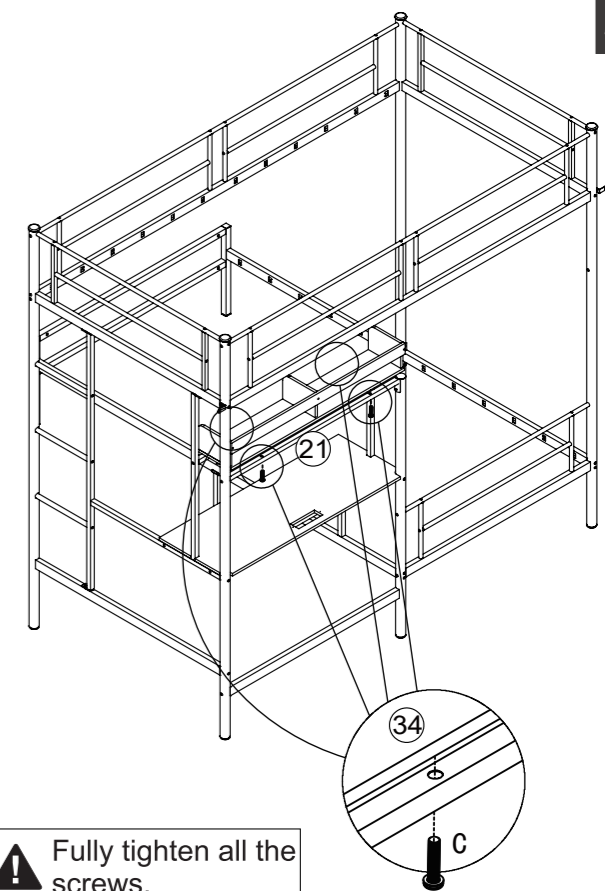

! Fully tighten all the screws.

C  4pcs

20

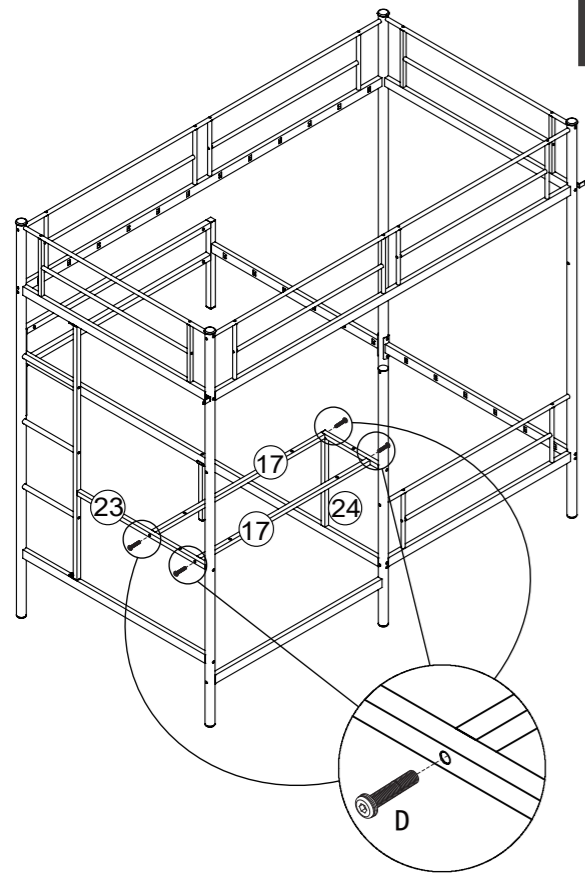

D		M8x35	4pcs
---	---	-------	------

⚠ Do not fully tighten the screws yet.



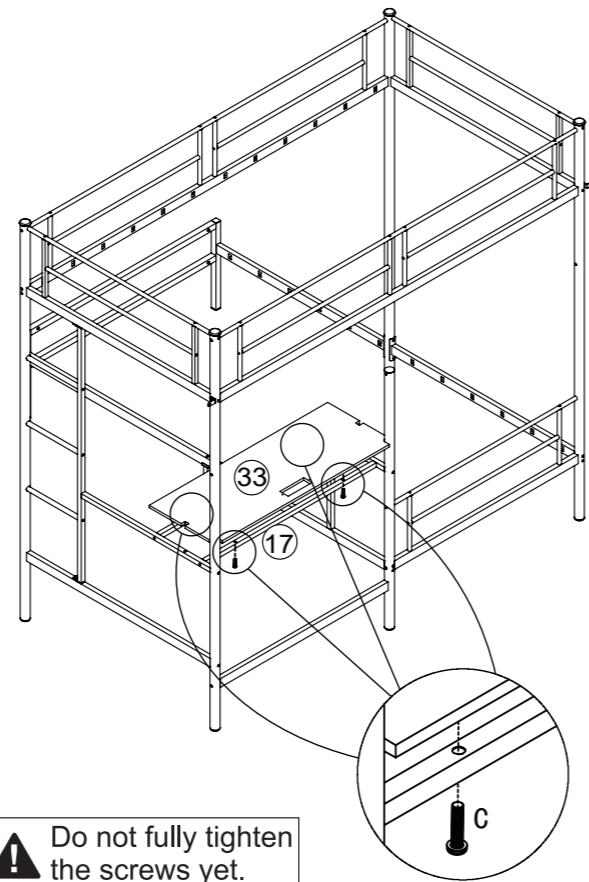

21





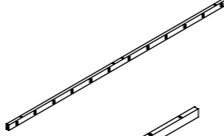
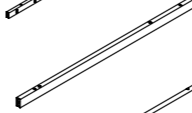

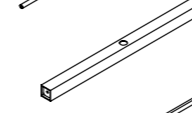
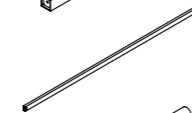
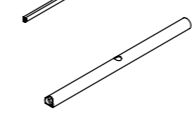
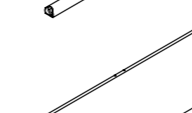
⚠ Do not fully tighten the screws yet.

C		M8x30	4pcs
---	---	-------	------

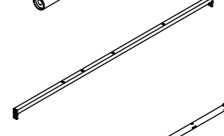
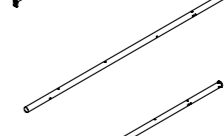
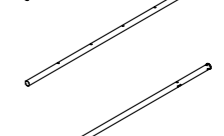
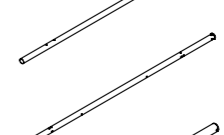
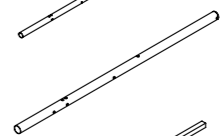

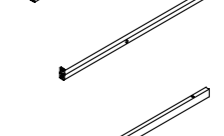
Components

-  1 x2pcs
-  2 x2pcs
-  3 x3pcs
-  4 x4pcs
-  5 x24pcs
-  6 x10pcs
-  7 x2pcs
-  8 x7pcs
-  9 x1pc

-  10 x3pcs
-  11 x1pc
-  12 x1pc
-  13 x1pc
-  14 x1pc
-  15 x1pc
-  16 x1pc
-  17 x2pcs
-  18 x1pc
-  19 x1pc

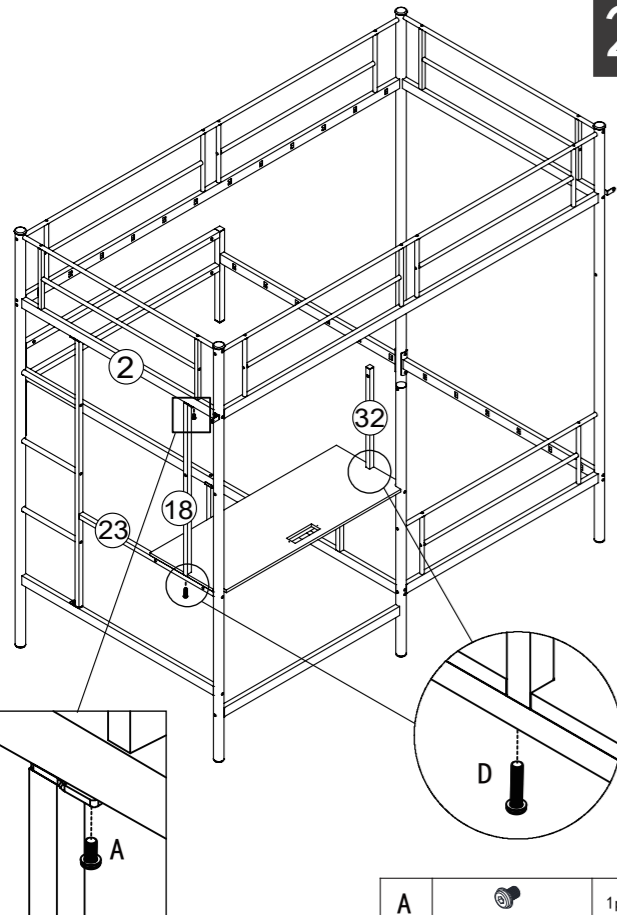
22





A		M8x16	1pc
D		M8x35	2pcs

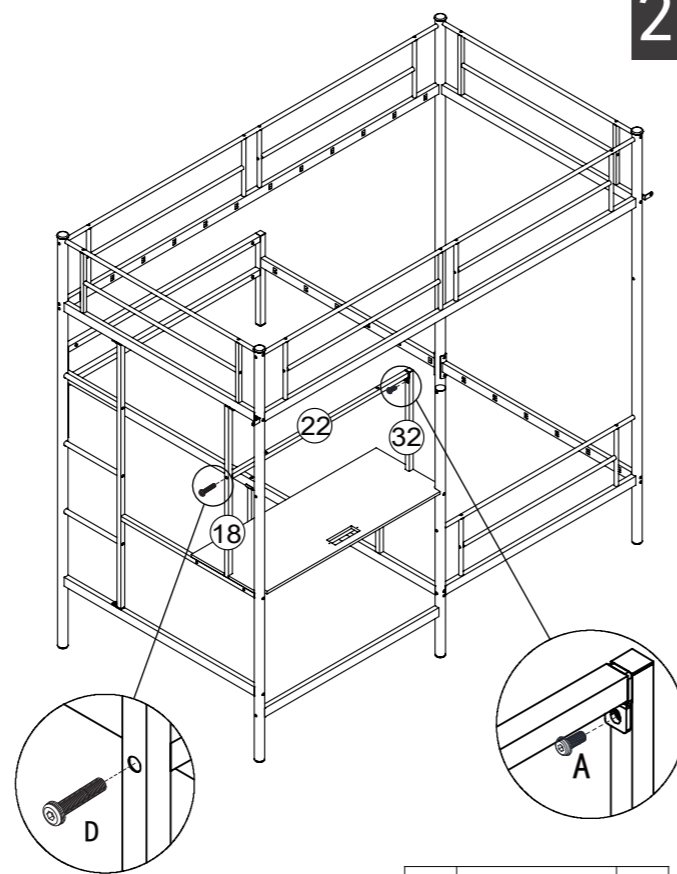

23





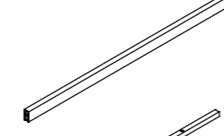
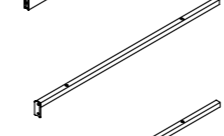
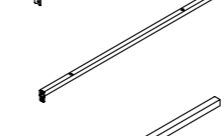
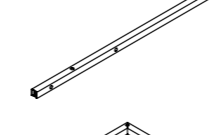
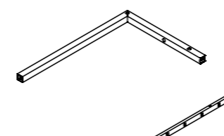
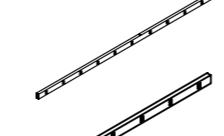
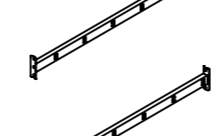
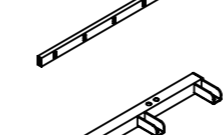
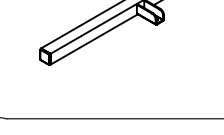

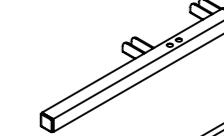
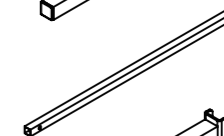
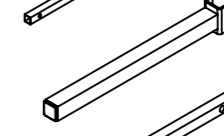
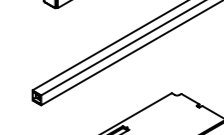
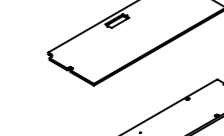
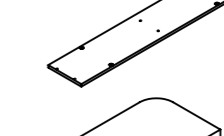
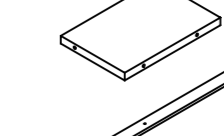









⚠ Do not fully tighten the screws yet.

A		M8x16	1pc
D		M8x35	1pc

-  20 x1pc
-  21 x1pc
-  22 x1pc
-  23 x1pc
-  24 x1pc
-  25 x1pc
-  26 x1pc
-  27 x1pc
-  28 x1pc

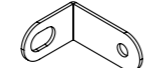

-  29 x1pc
-  30 x2pcs
-  31 x1pc
-  32 x1pc
-  33 x1pc
-  34 x1pc
-  35 x3pcs
-  36 x1pc

-  M8x16 **A** x11pcs
-  M8x25 **B** x24pcs
-  M8x30 white zinc **C** x8pcs
-  M8x35 **D** x19pcs
-  M8x55 **E** x54pcs
-  M5x40 **F** x9pcs
-  ST4x14 **G** x2pcs
-  M8 **H** x2pcs
-  **I** x48pcs

-  M8 **J** x1pc
-  M5 **K** x1pc
-  **L** x1pc
-  **U** x1pc
-  **Y** x2pcs
-  **Z** x2pcs

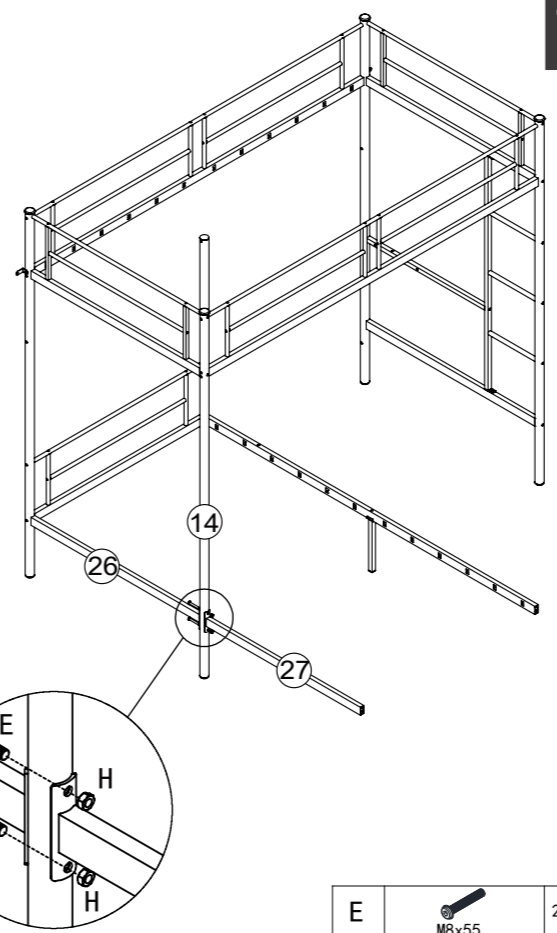
16



E		2pcs
H		2pcs

17

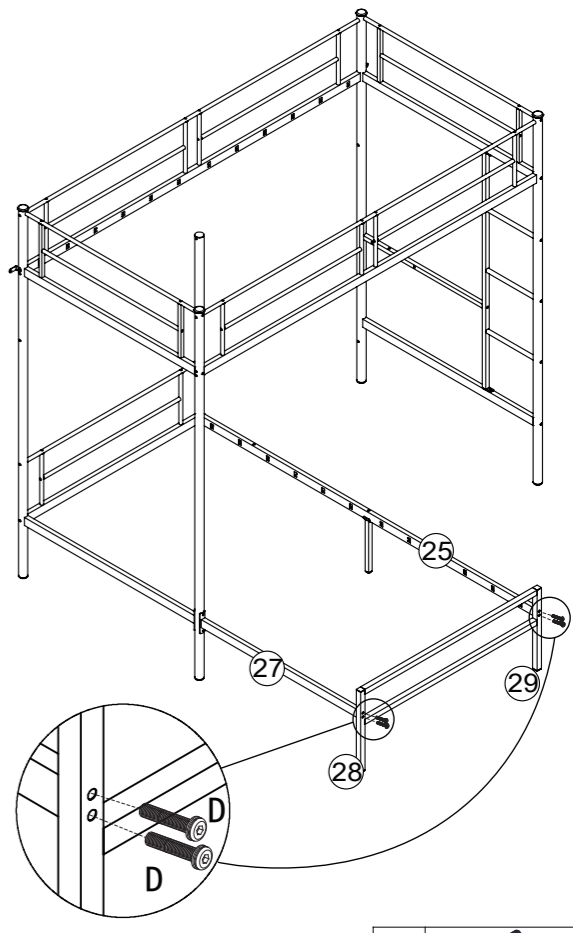

D		4pcs
---	---	------

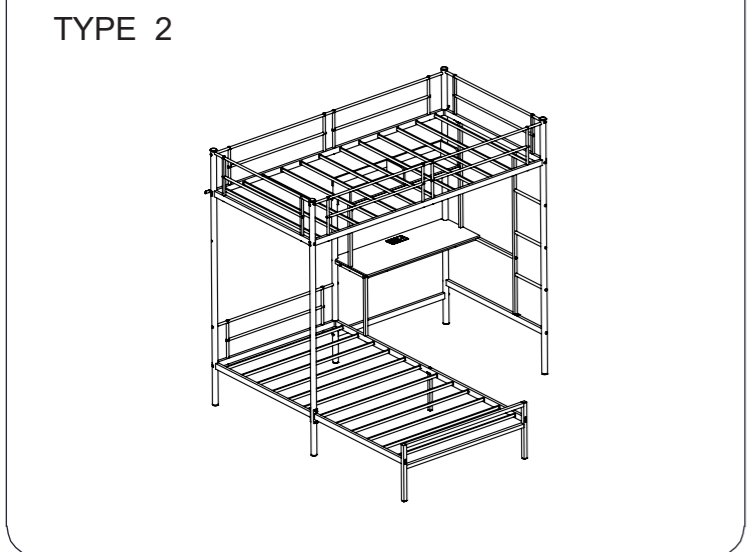
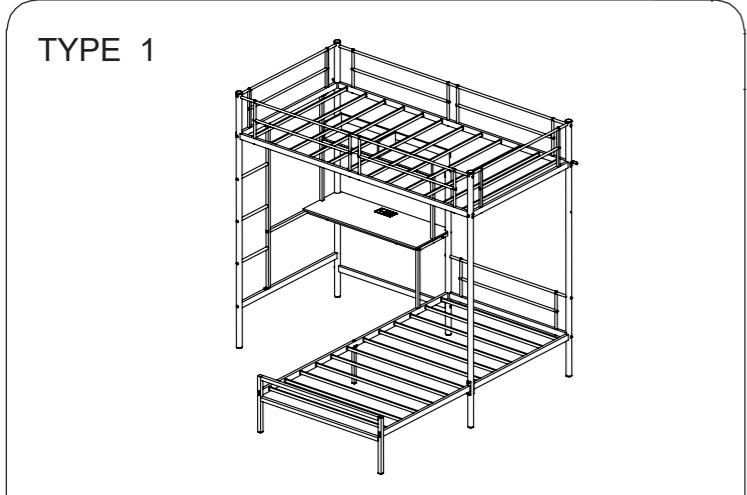

18

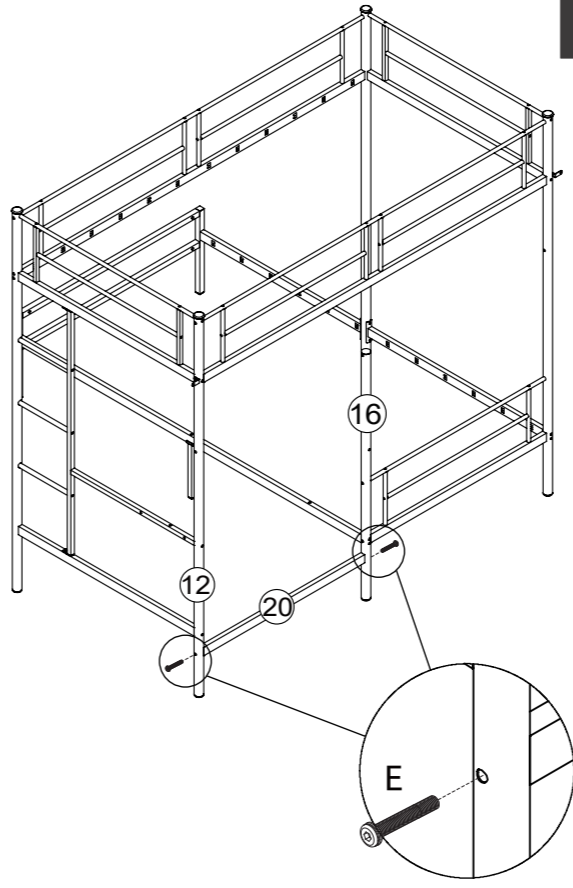

E		2pcs
---	---	------

! Do not fully tighten the screws yet.

19

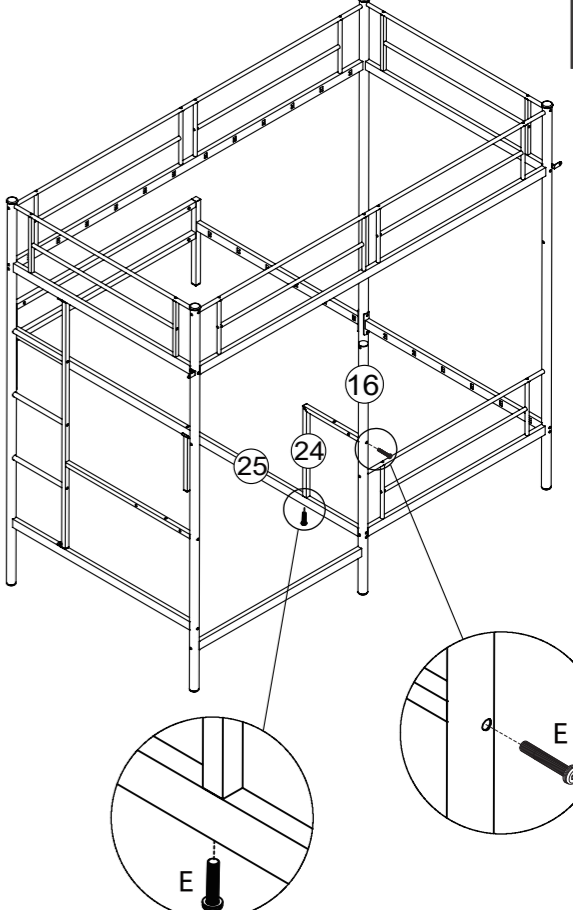

E		2pcs
---	---	------

12

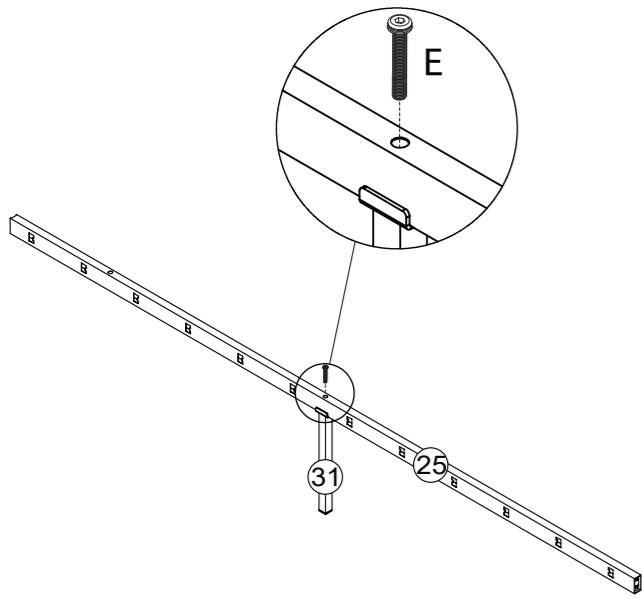

E		M8x55	1pc
---	---	-------	-----

13

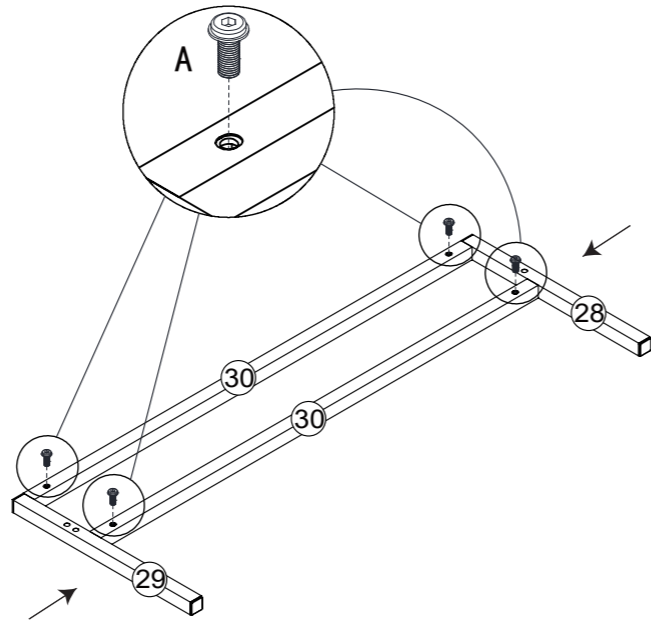

A		M8x16	4pcs
---	---	-------	------

1

x2

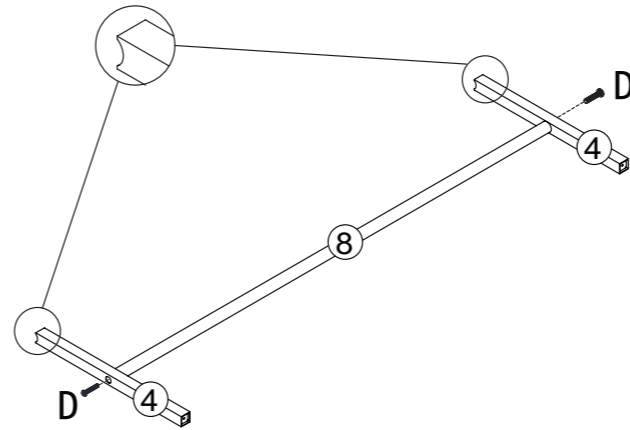



D		M8x35	4pcs
---	---	-------	------

2

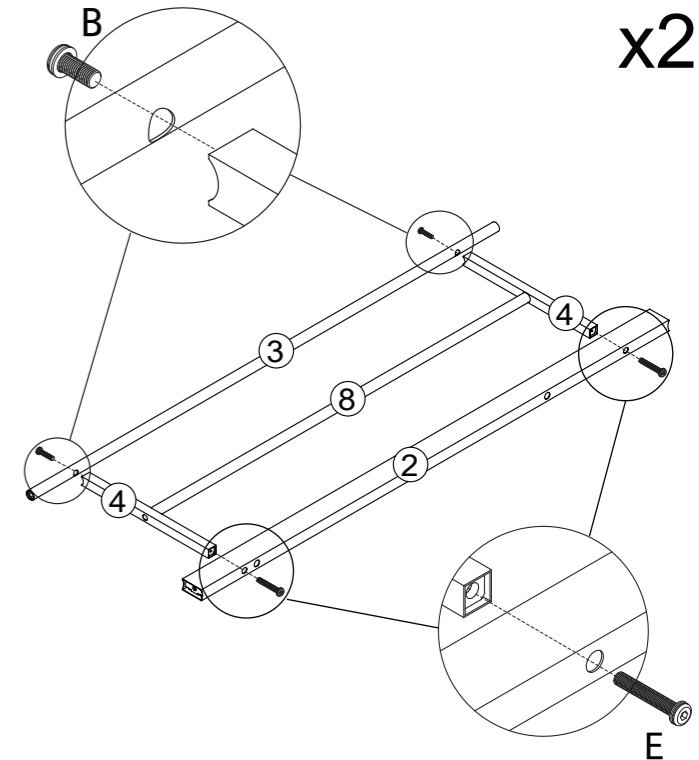
x2



B		M8x25	4pcs
E		M8x55	4pcs

14

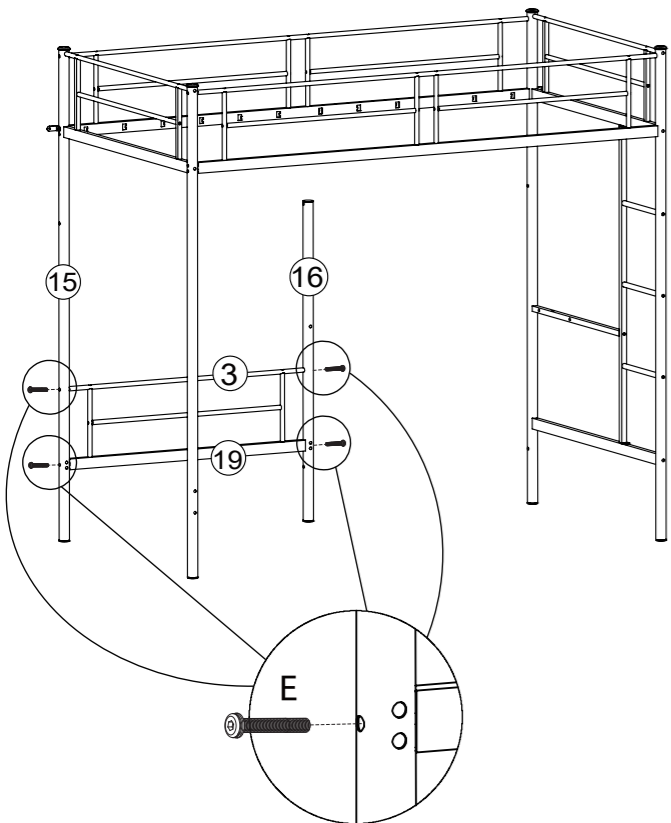

E		M8x55	4pcs
---	---	-------	------

 Do not fully tighten the screws yet.

15

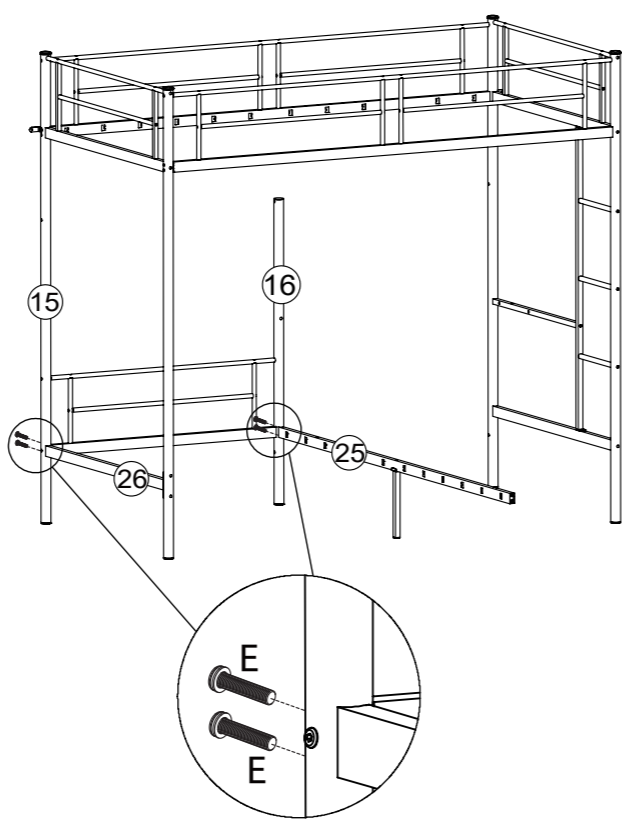

E		M8x55	4pcs
---	---	-------	------

 Do not fully tighten the screws yet.

3

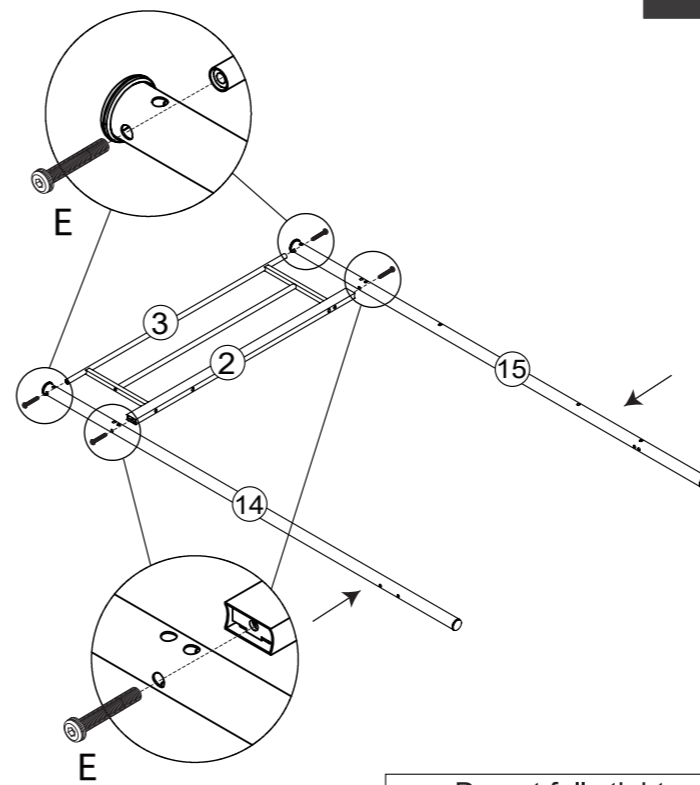

E		M8x55	4pcs
---	---	-------	------

 Do not fully tighten the screws yet.

4

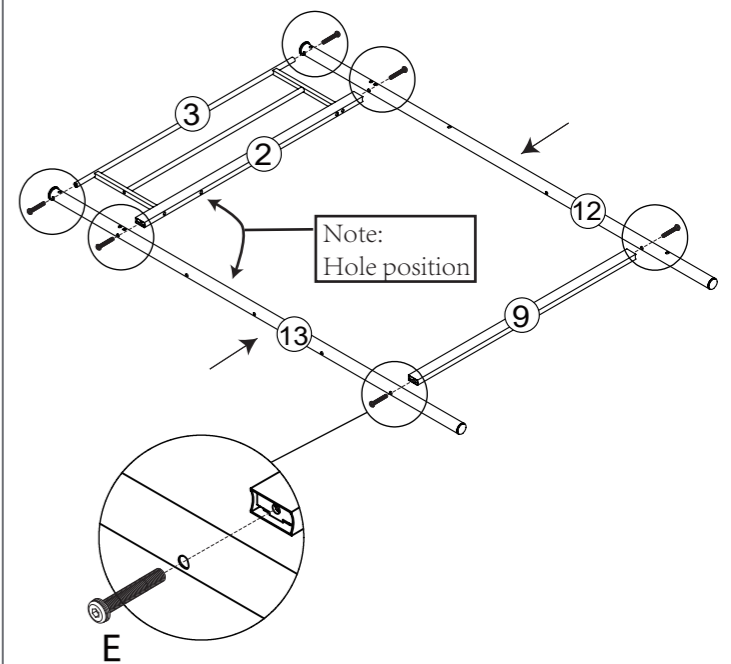



E		M8x55	6pcs
---	---	-------	------

 Do not fully tighten the screws yet.

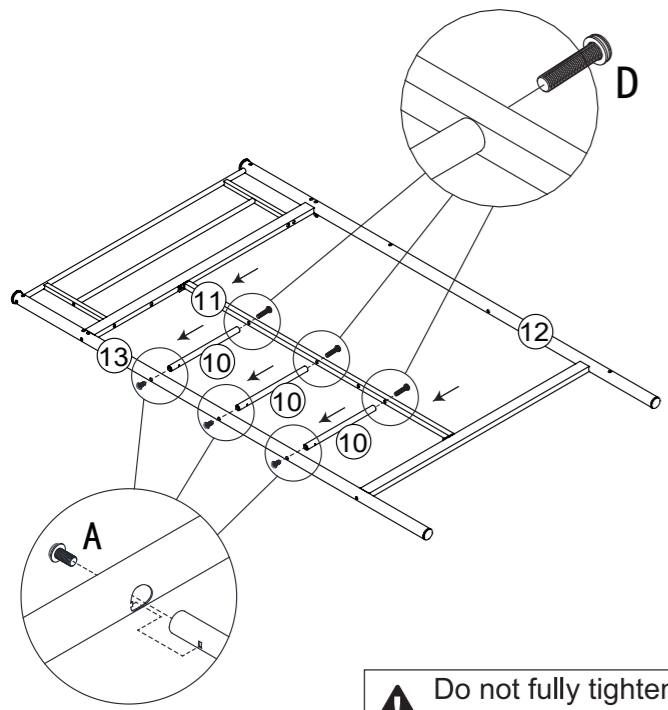
5



⚠ Do not fully tighten the screws yet.

A	 M8x16	3pcs
D	 M8x35	3pcs

6

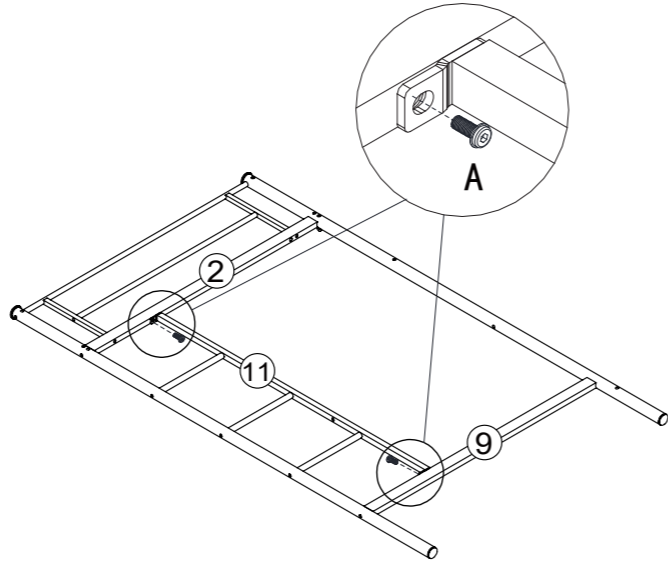

⚠ Do not fully tighten the screws yet.

A	 M8x16	2pcs
---	---	------

8

x5

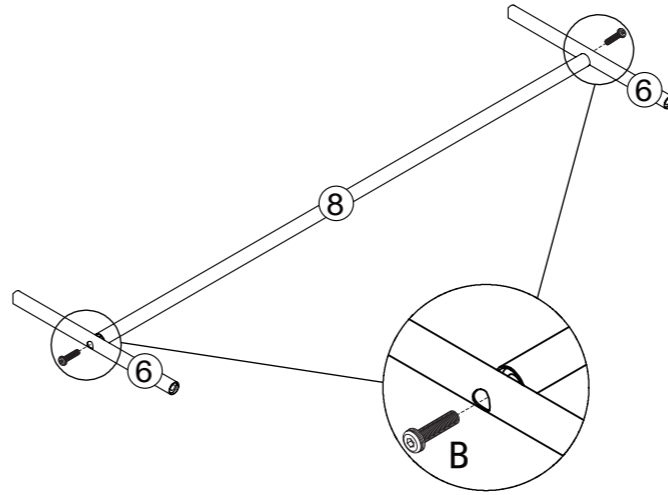



B	 M8x25	10pcs
---	---	-------

9

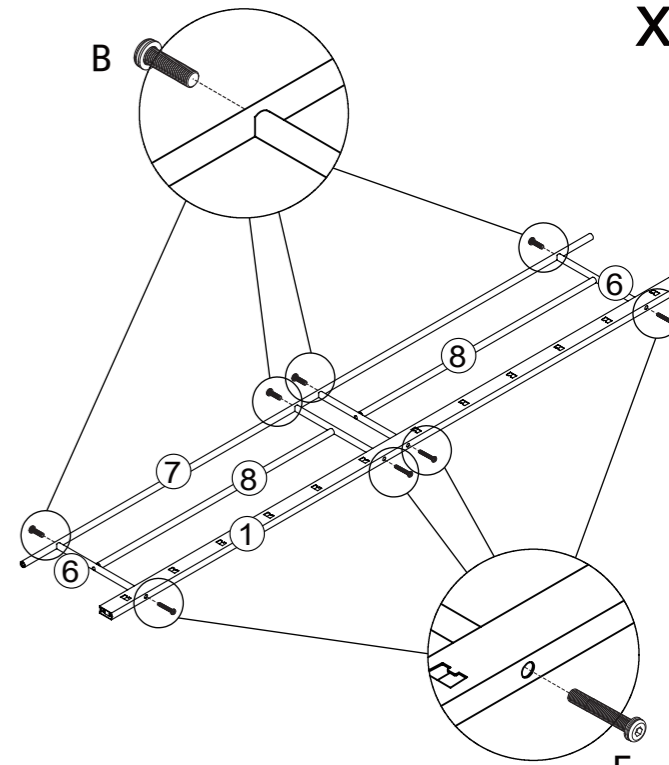

x2

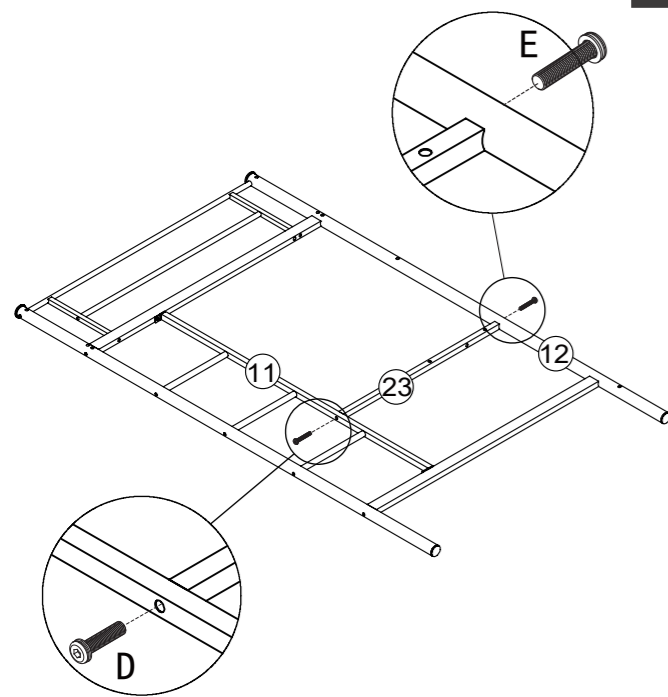

B	 M6x25	8pcs
E	 M8x55	8pcs

7



D	 M8x35	1pc
E	 M8x55	1pc

8

x5

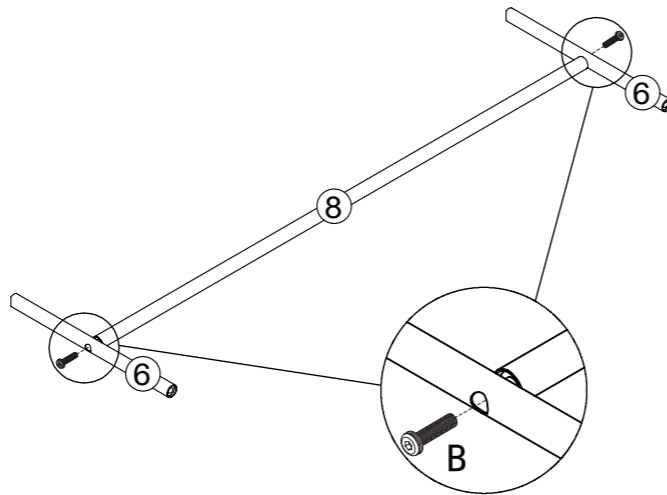

B	 M8x25	10pcs
---	---	-------

10

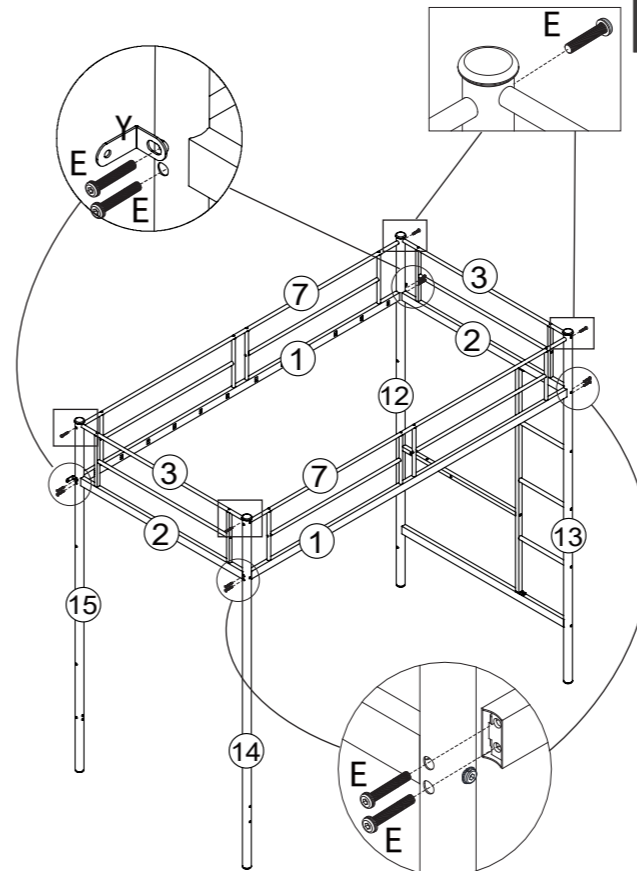



E	 M8x55	12pcs
---	---	-------

⚠ Fully tighten all the screws.

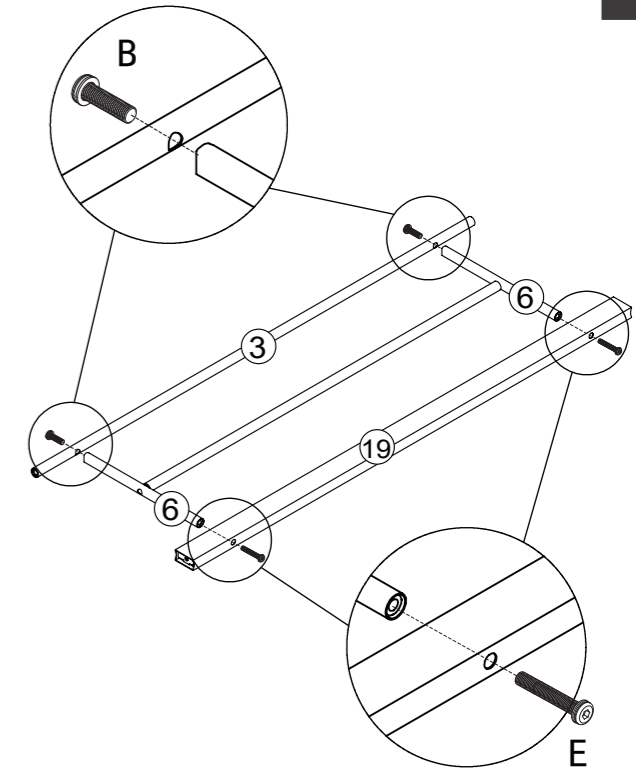
11



B	 M8x25	2pcs
E	 M8x55	2pcs

4

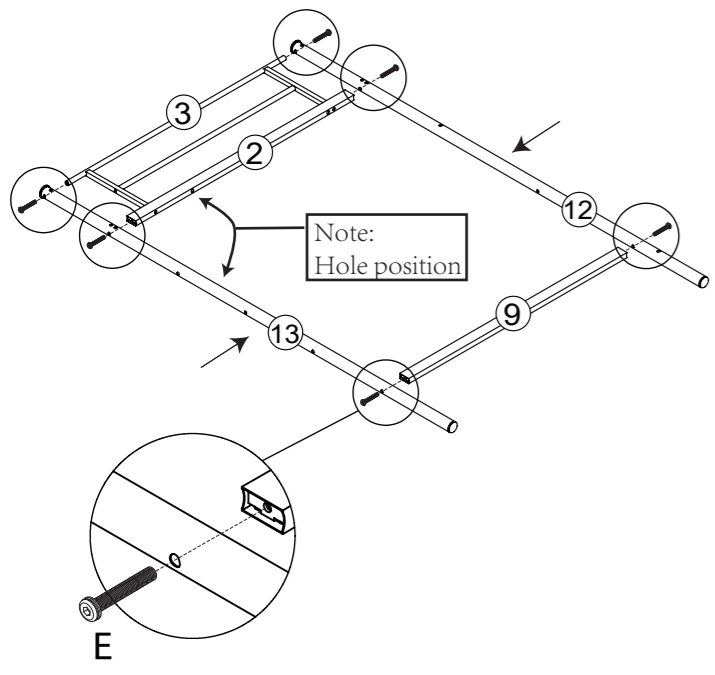

⚠ Do not fully tighten the screws yet.

E		M8x55	6pcs
---	--	-------	------

5

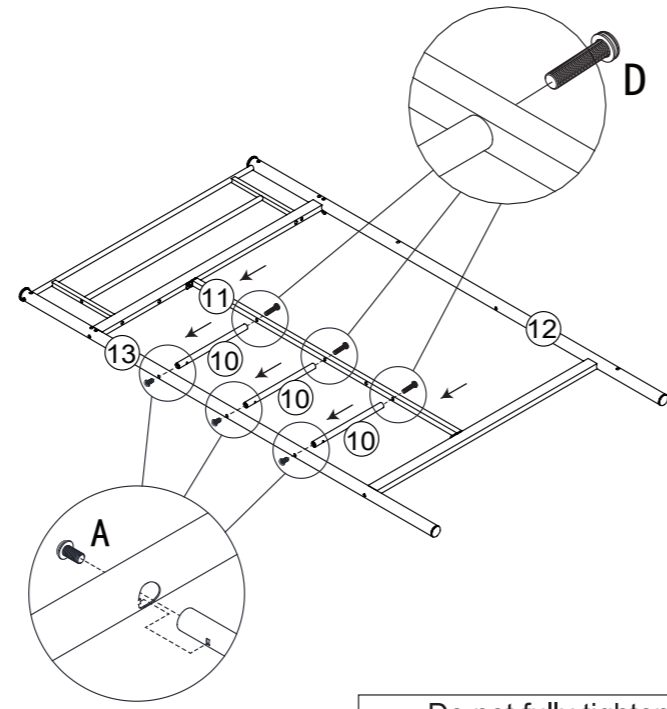

⚠ Do not fully tighten the screws yet.

A		M8x16	3pcs
D		M8x35	3pcs

9

x2

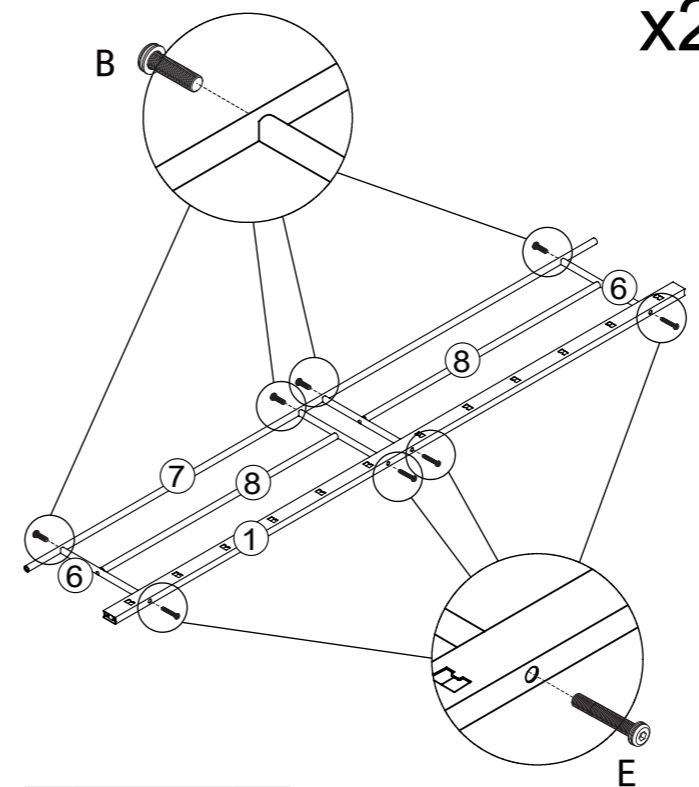

B		M8x25	8pcs
E		M8x55	8pcs

10

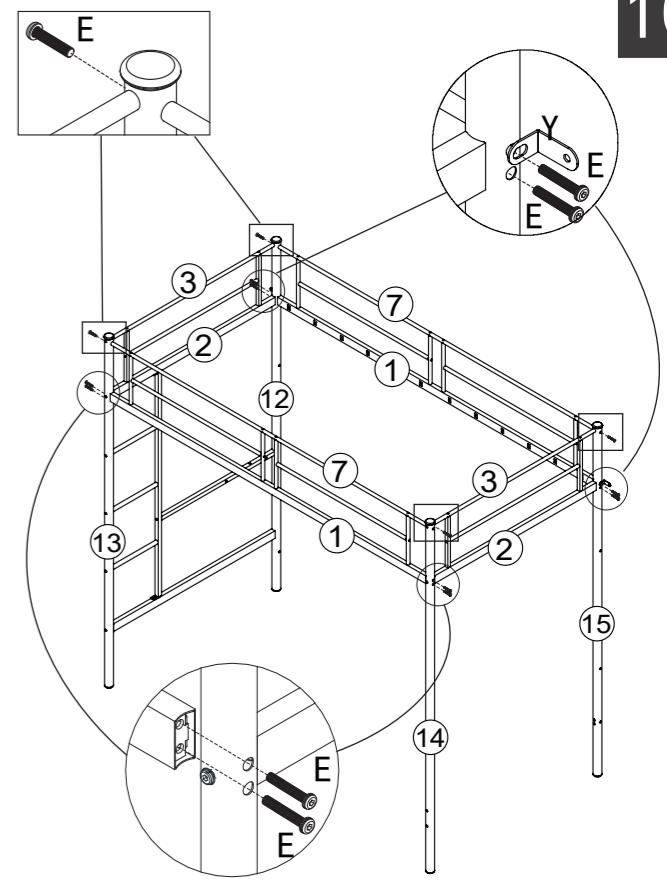

⚠ Fully tighten all the screws.

E		M8x55	12pcs
---	--	-------	-------

6

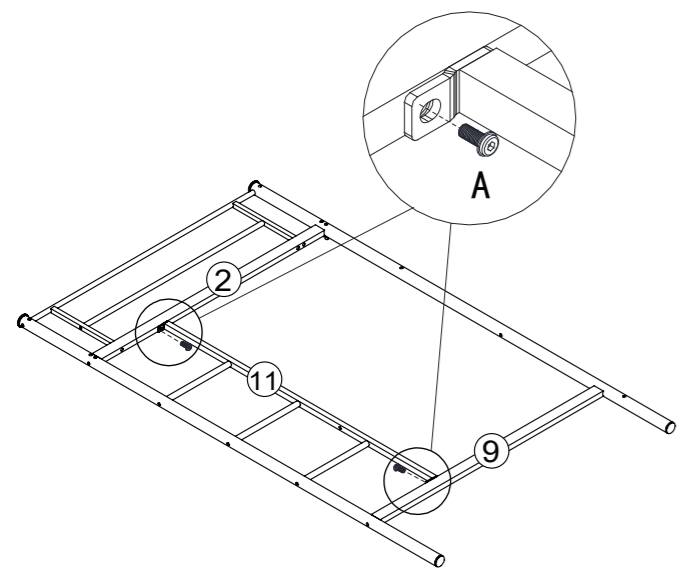

⚠ Do not fully tighten the screws yet.

A		M8x16	2pcs
---	--	-------	------

7

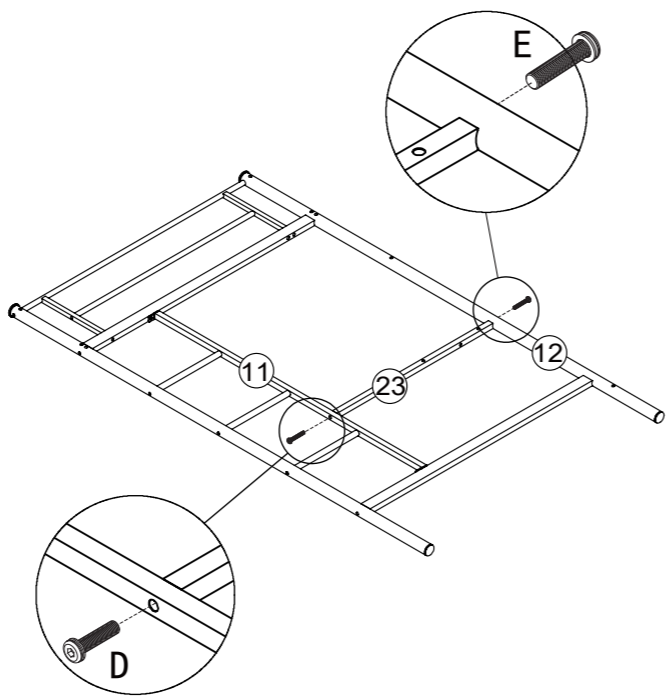

D		M8x35	1pc
E		M8x55	1pc

11

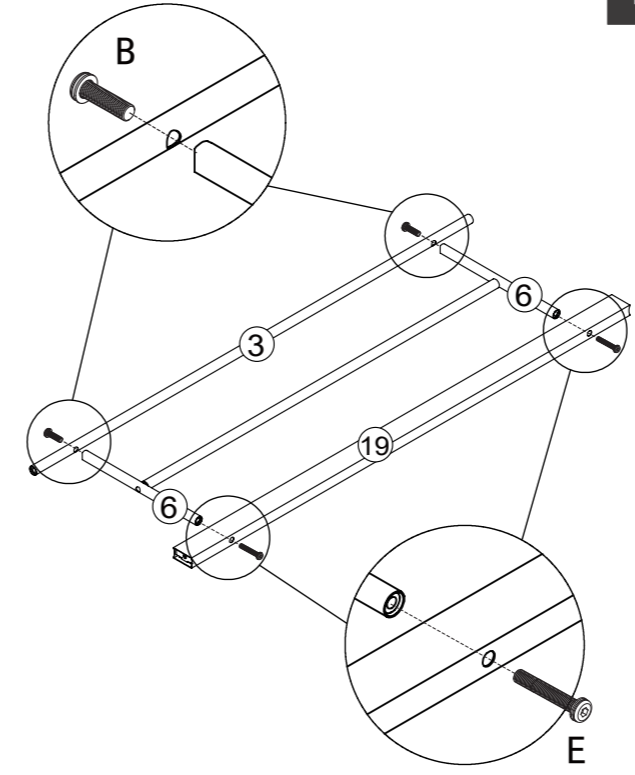

B		M8x25	2pcs
E		M8x55	2pcs

12

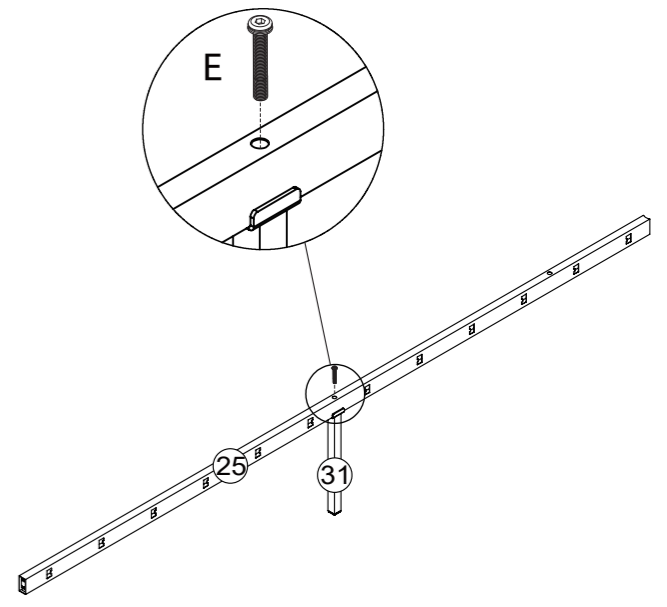

E		M8x55	1pc
---	--	-------	-----

13

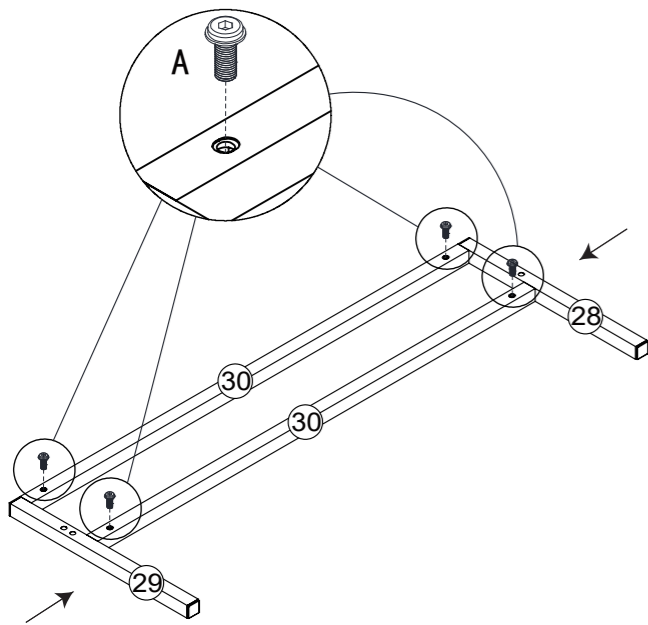

A		M8x16	4pcs
---	--	-------	------

14

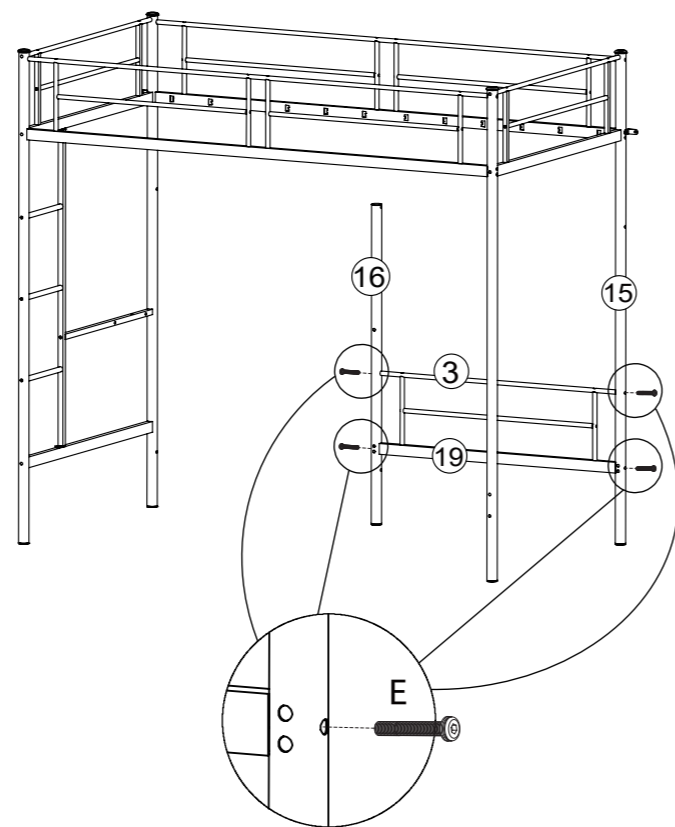

E		M8x55	4pcs
---	--	-------	------

Do not fully tighten the screws yet.

TYPE 2

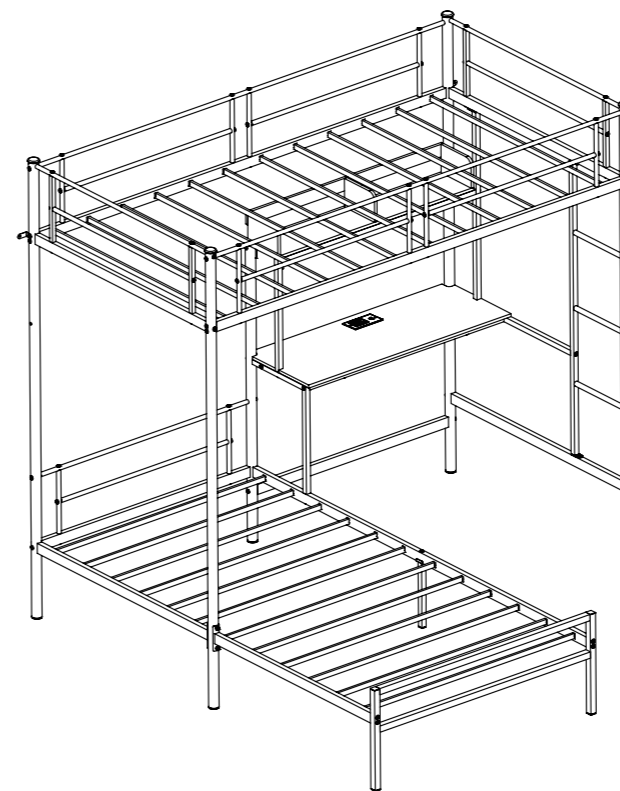

1

x2

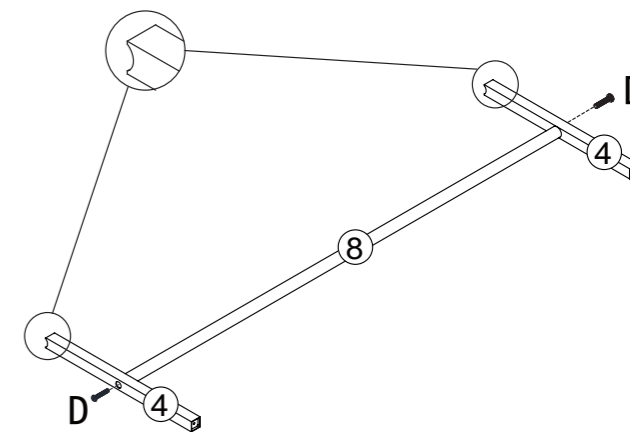

D		M8x35	4pcs
---	--	-------	------

15

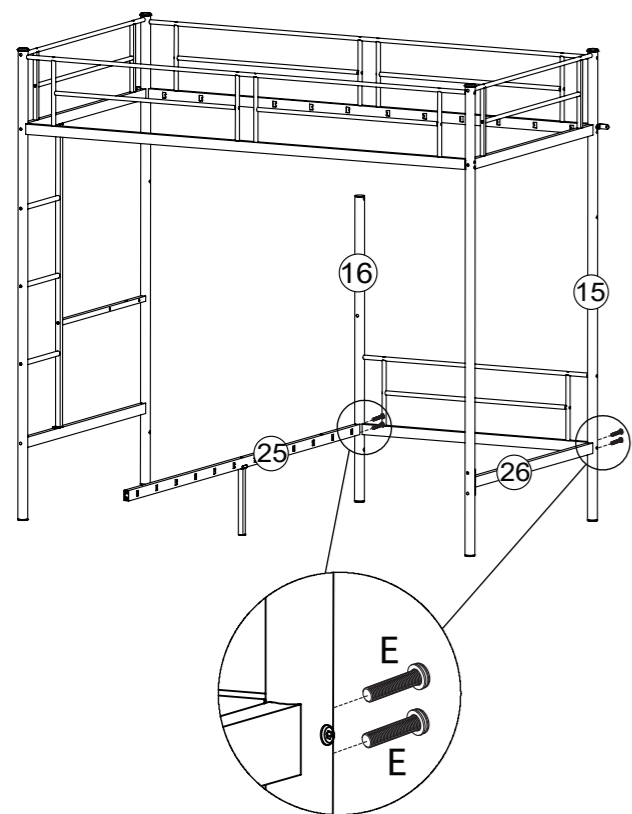

E		M8x55	4pcs
---	--	-------	------

Do not fully tighten the screws yet.

16

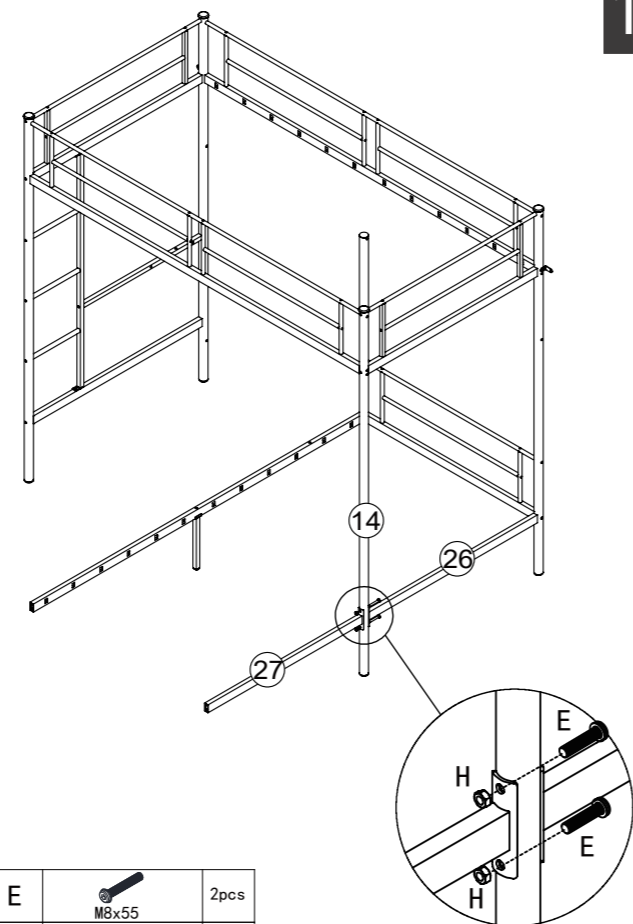

E		M8x55	2pcs
H			2pcs

2

x2

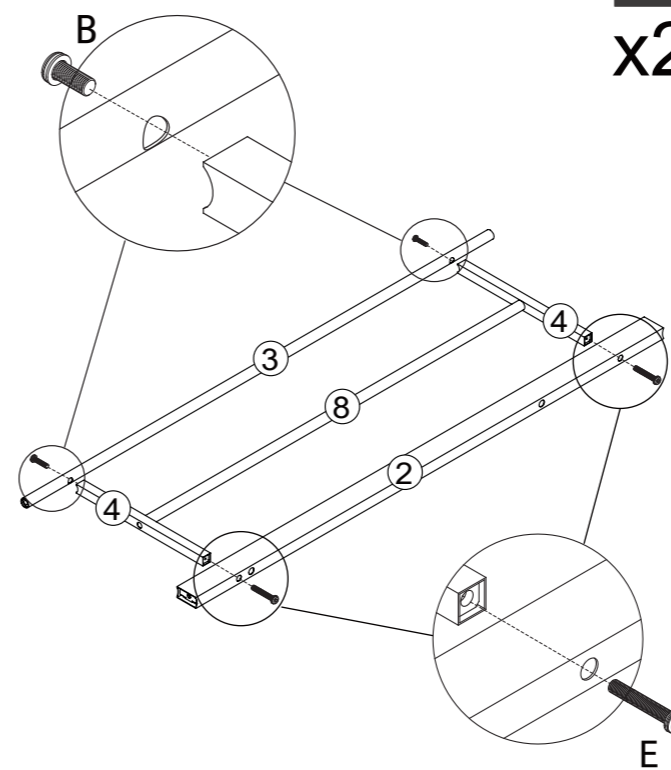

B		M8x25	4pcs
E		M8x55	4pcs

3

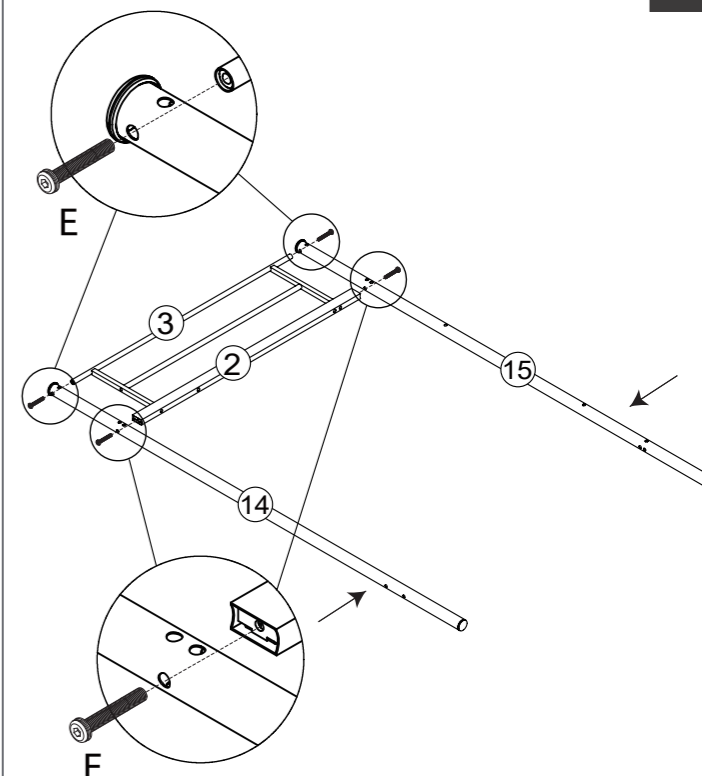

E		M8x55	4pcs
---	--	-------	------

Do not fully tighten the screws yet.

29

I  48pcs

30

1: Using a drill bit with a diameter of 6, drill mounting holes where installation is required
 2: Place the expansion tube into the hole
 3: Screw the screw together with the mounting part into the expansion pipe

Z  2pcs

17

D  M8x35 4pcs

18

E  M8x55 2pcs

! Do not fully tighten the screws yet.

Finish

! Do not climb on the bed.

Note: Now you can tighten all the bolts.

31

19

E  M8x55 2pcs

20

D  M8x35 4pcs

! Do not fully tighten the screws yet.

21

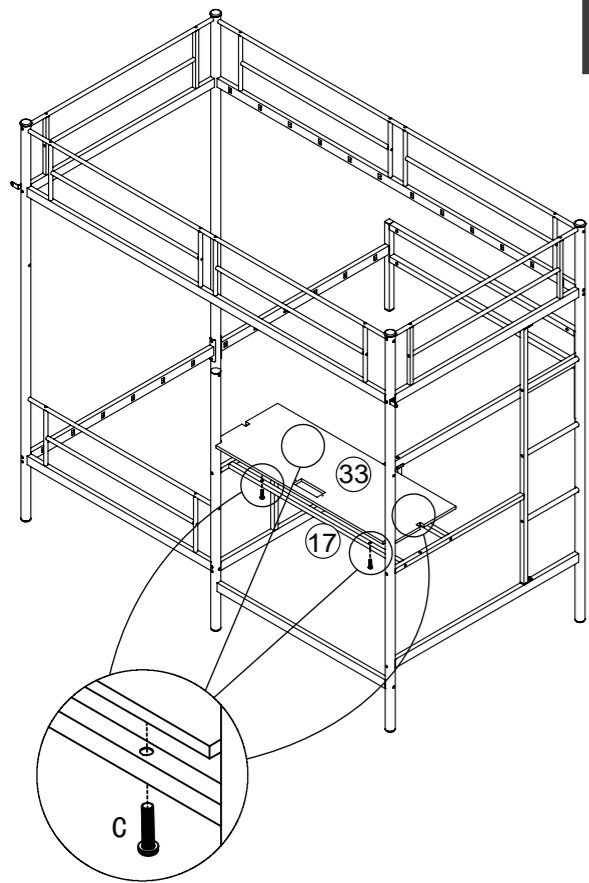



C		M8x30	4pcs
---	---	-------	------

⚠ Do not fully tighten the screws yet.

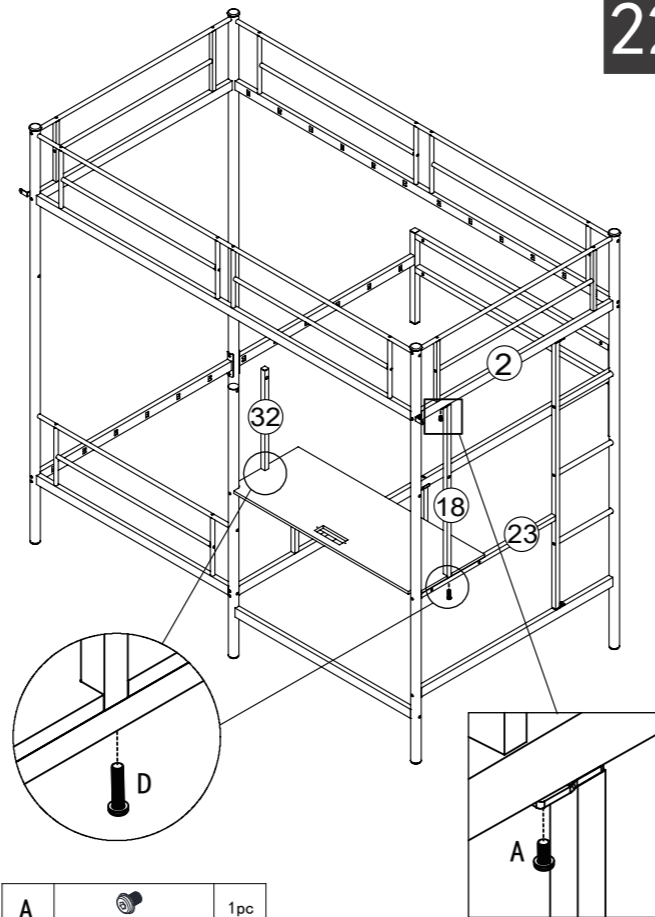
22



A		M8x16	1pc
D		M8x35	2pcs

25

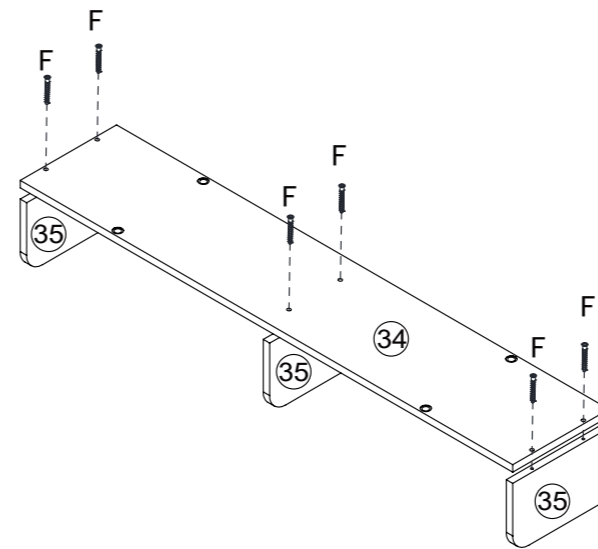

F		M5x40	6pcs
---	---	-------	------

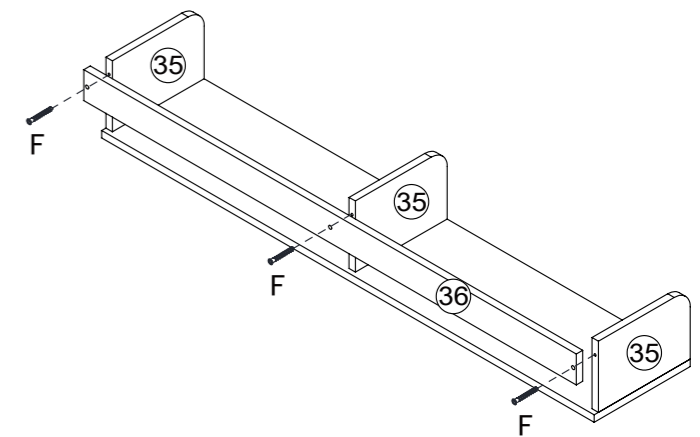

26

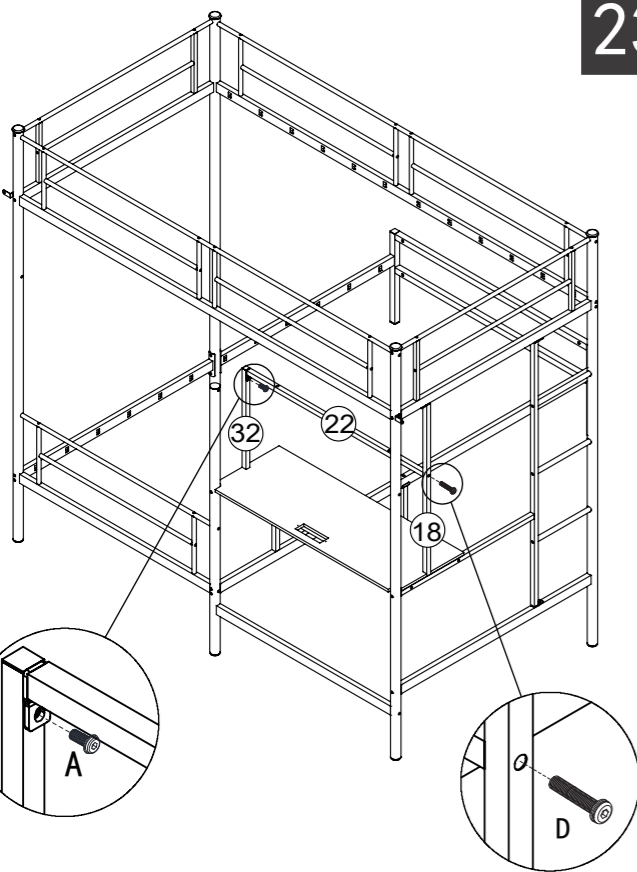

F		M5x40	3pcs
---	---	-------	------

23



A		M8x16	1pc
D		M8x35	1pc

⚠ Do not fully tighten the screws yet.

24

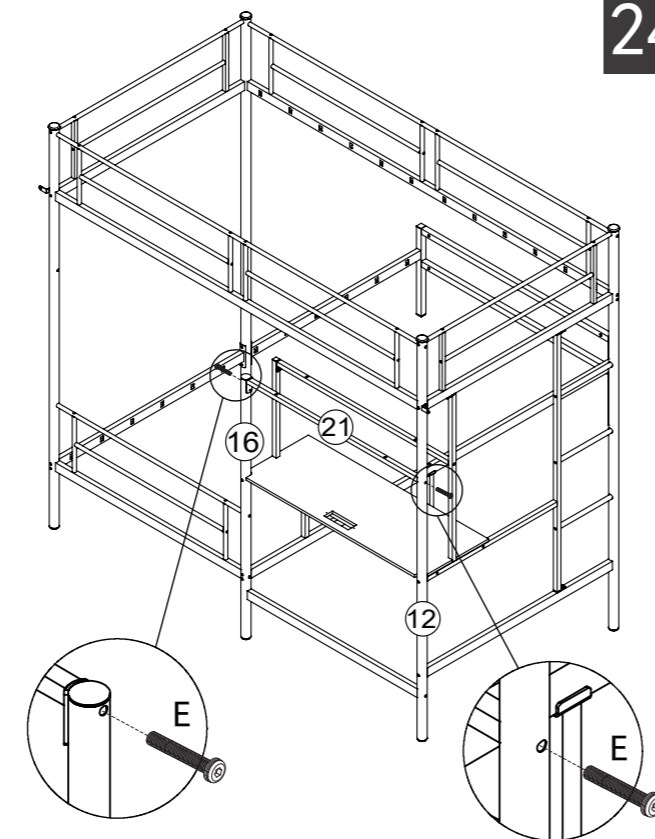

E		M8x55	2pcs
---	---	-------	------

⚠ Do not fully tighten the screws yet.

27

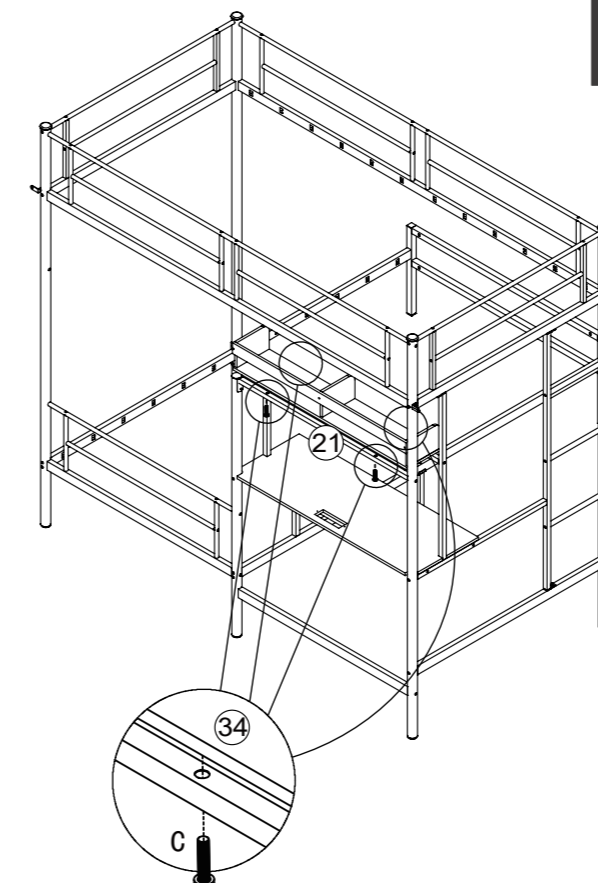

C		M8x30	4pcs
---	---	-------	------

⚠ Fully tighten all the screws.

28

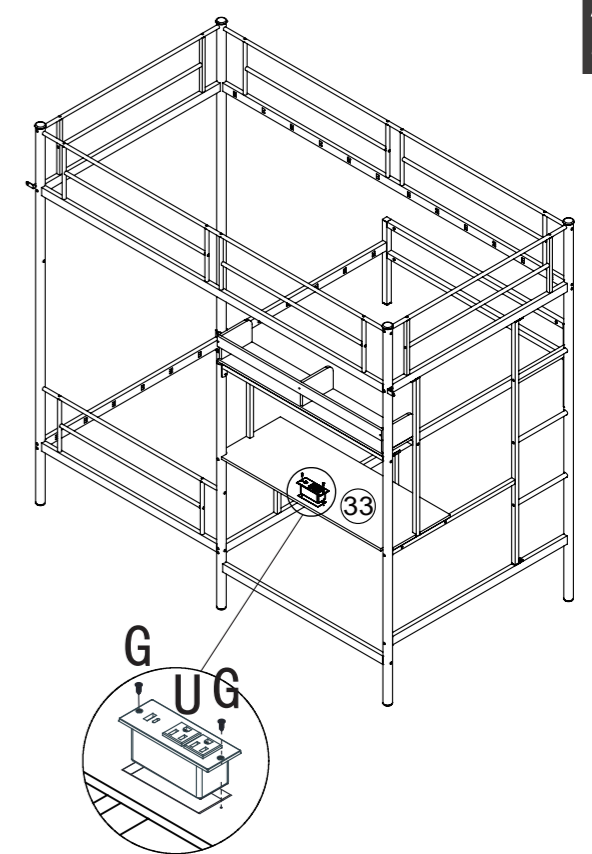

G		ST4x14	2pcs
---	---	--------	------