

Installation & Assembly

Notice:

- 1. Follow the installation instructions. Please confirm all accessories are preset before installation.**
- 2. Do not fully tighten screws during initial assembly. Gently adjust the board to make them level. Only tighten after all pieces are correctly assembled.**
- 3. If you encounter any problems during installation, refer to two solutions: Follow the installation video tutorial on the Amazon product page or contact our customer service.**

Beachten:

- 1. Befolgen Sie die Installationsanweisungen. Bitte bestätigen Sie vor der Installation, dass alle Zubehörteile voreingestellt sind.**
- 2. Ziehen Sie die Schrauben bei der Erstmontage nicht vollständig an. Stellen Sie das Board vorsichtig so ein, dass es eben ist. Erst festziehen, wenn alle Teile richtig zusammengesetzt sind.**
- 3. Wenn während der Installation Probleme auftreten, finden Sie zwei Lösungen: Befolgen Sie das Installationsvideo-Tutorial auf der Amazon-Produktseite oder wenden Sie sich an unseren Kundendienst.**

Remarques:













- 1. Suivez les instructions d'installation. Assurez-vous que toutes les pièces jointes sont prépositionnées avant l'installation svp.**
- 2. Ne serrez pas complètement les vis lors de l'installation initiale. Ajustez doucement les plaques pour les niveler. Serrez seulement après que tous les composants ont été assemblés correctement.**
- 3. Si vous rencontrez des problèmes lors de l'installation, référez-vous à deux solutions: suivez le didacticiel vidéo d'installation sur la page de produit Amazon ou contactez notre service à la clientèle.**



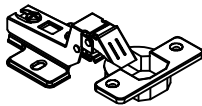

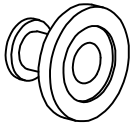
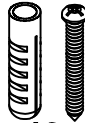

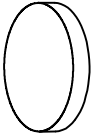
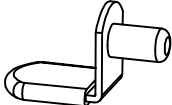
Nota:



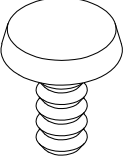
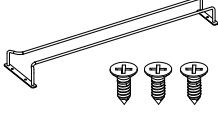

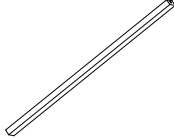
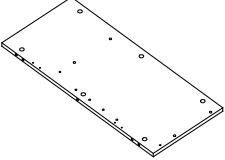
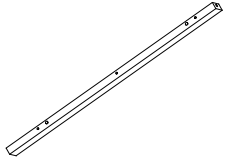
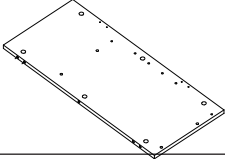
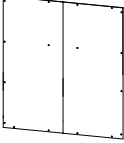
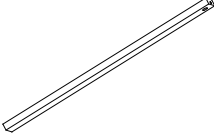
- 1. Seguire le istruzioni di installazione. Assicurarsi che tutti gli accessori siano preregolati prima dell'installazione.**
- 2. Non avvitare completamente le viti durante l'assemblaggio iniziale. Regolare delicatamente le assi per livellarle. Avvitare solo quando tutti i pezzi sono assemblati correttamente.**
- 3. Se incontri qualsiasi problema durante l'installazione, fai riferimento a queste due soluzioni: Segui il video tutorial d'installazione sulla pagina Amazon del prodotto o contatta il nostro servizio clienti.**

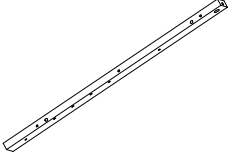
Aviso:

- 1. Siga las instrucciones de instalación. Revise que todos los accesorios estén en condiciones antes de la instalación.**
- 2. No apriete los tornillos por completo durante la instalación inicial. Ajuste suavemente el tablero para nivelar. Apriete por completo una vez que todas las piezas estén colocadas correctamente.**
- 3. Si encuentra algún problema durante la instalación: siga el video tutorial de instalación en la página del producto en Amazon, o póngase en contacto con nuestro servicio de atención al cliente.**

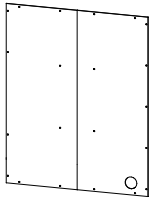
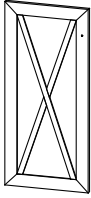
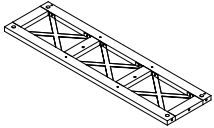
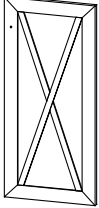
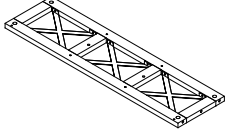
Item no. Nr. N° d'article Articolo No. Artículo No.	Reference Image Referenzbild Image de référence Immagine di riferimento Imagen de referencia	Qty. Menge Qté. Qtà Cant.	Item no. Nr. N° d'article Articolo No. Artículo No.	Reference Image Referenzbild Image de référence Immagine di riferimento Imagen de referencia	Qty. Menge Qté. Qtà Cant.
A		X50+5	H	 M3.5x12	X42+4
B	 Ø8x30	X32+3	I	 M3.5x14	X16+1
C	 Ø15	X50+5	J		X46+4
D		X4	K		X2
E		X2	L	 32x19x19	X2
F	 M4x18	X2	M		X2
G		X4	-		X1

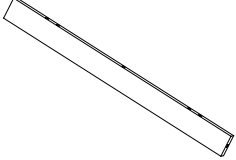
Item no. Nr. N° d'article Articolo No. Artículo No.	Reference Image Referenzbild Image de référence Immagine di riferimento Imagen de referencia	Qty. Menge Qté. Qtà Cant.	Item no. Nr. N° d'article Articolo No. Artículo No.	Reference Image Referenzbild Image de référence Immagine di riferimento Imagen de referencia	Qty. Menge Qté. Qtà Cant.
N		×4	O		×1
1		×1	6		×1
2		×1	7		×1
3		×1	8		×1
4		×1	9		×1
5		×1	10		×1

Item no. Nr. N° d'article Articolo No. Artículo No.	Reference Image Referenzbild Image de référence Immagine di riferimento Imagen de referencia	Qty. Menge Qté. Qtà Cant.	Item no. Nr. N° d'article Articolo No. Artículo No.	Reference Image Referenzbild Image de référence Immagine di riferimento Imagen de referencia	Qty. Menge Qté. Qtà Cant.
11		×1	16		×1
12		×1	17		×1
13		×1	18		×1
14		×1	19		×1
15		×2	20		×1

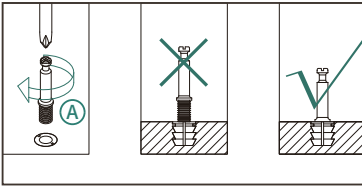

Tighten Ⓐ clockwise until all of their threads are engaged.

Ziehen Sie die Ⓐ im Uhrzeigersinn an, bis alle Gewindengänge eingerastet sind

Serrez les Ⓐ dans le sens des aiguilles d'une montre jusqu'à ce que tous leurs filets soient engagés.

Serrare Ⓐ in senso orario fino a quando tutte le filettature sono impegnate.

Apriete Ⓐ en el sentido de las agujas del reloj hasta que todas sus roscas estén engranadas.

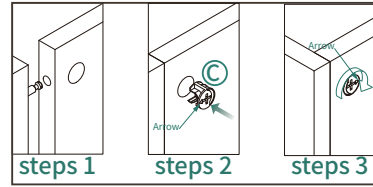

Step 1/2/3

Arrow

The two plates fit vertically, place Ⓒ and match their holes with Ⓒ, then tighten Ⓒ clockwise.

Stufe 1/2/3

Pfeil

Die beiden Platten passen senkrecht aufeinander, legen Ⓒ und ihre Löcher mit Ⓒ übereinstimmen, dann Ⓒ im Uhrzeigersinn anziehen.

Étape 1/2/3

Flèche

Les deux plaques s'emboîtent verticalement, placez Ⓒ et faire correspondre leurs trous avec Ⓐ, puis serrer Ⓒ dans le sens des aiguilles d'une montre.

Passo 1/2/3

Freccia

Le due piastre si incastrano verticalmente, posizionando Ⓒ e far coincidere i fori con Ⓐ, quindi serrare Ⓒ in senso orario.

Paso 1/2/3

Flecha

Las dos placas encajan verticalmente, coloque Ⓒ y hacer coincidir sus orificios con los de la Ⓐ, y luego apretar Ⓒ en el

Note: It's better to use an electric drill when installing.

Hinweis: Verwenden Sie für die Installation besser eine elektrische Bohrmaschine.

Remarque : il est préférable d'utiliser une perceuse électrique lors de l'installation.

Nota: è consigliato utilizzare di utilizzare un trapano elettrico durante l'installazione.

Nota: Es mejor utilizar un taladro eléctrico para la instalación.

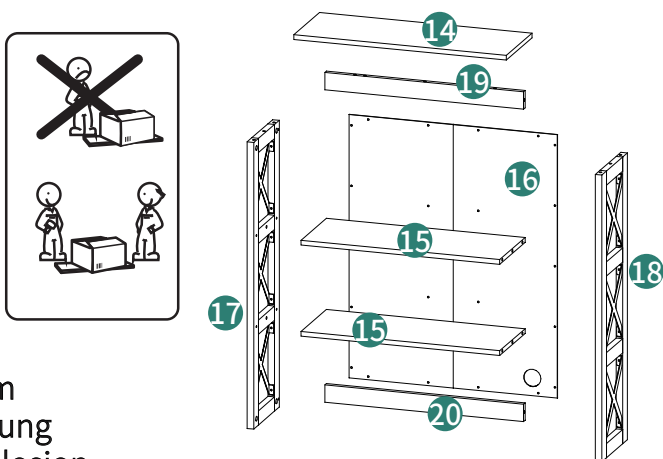

Explosion diagram

Explosionszeichnung

Diagramme d'explosion

Diagramma di esplosione

Diagrama de explosión

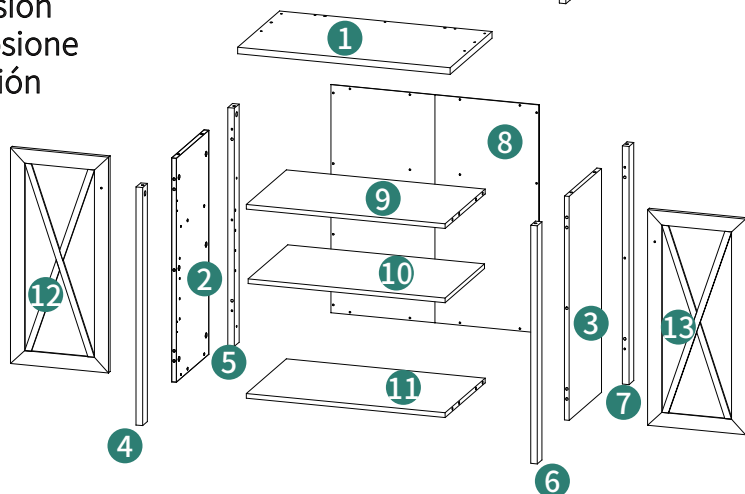

1

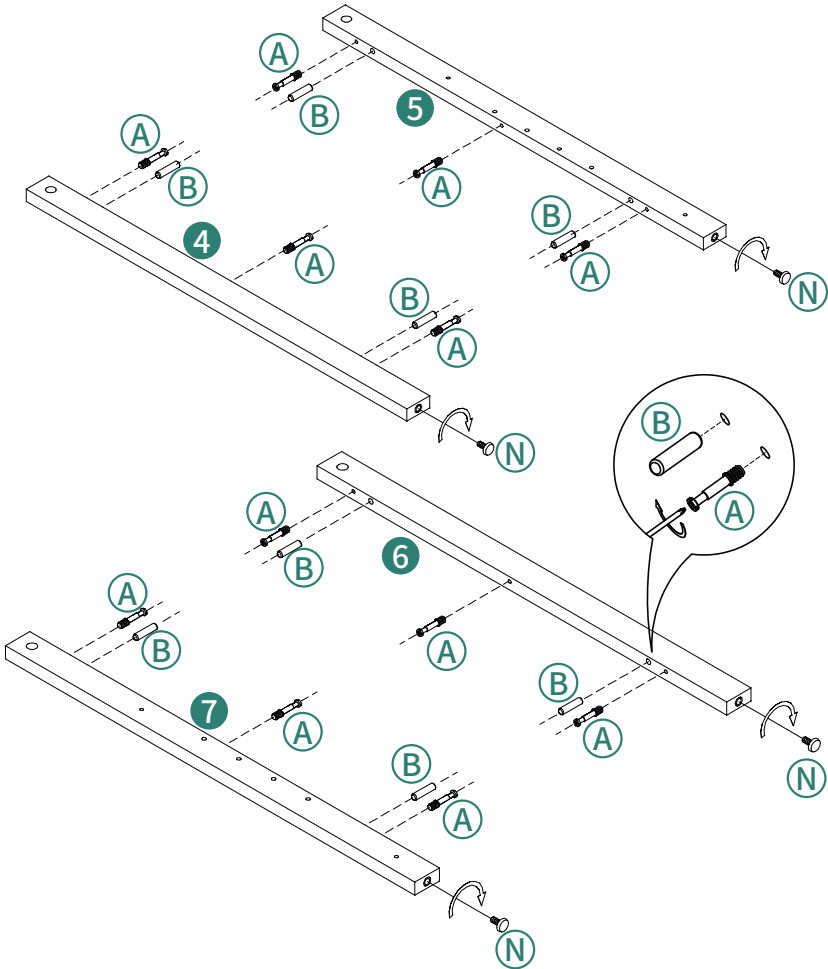
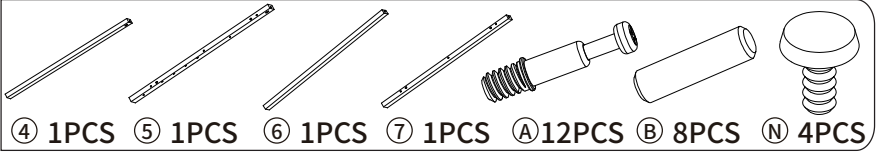

2

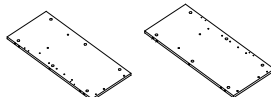

② 1PCS ③ 1PCS

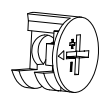

©12PCS

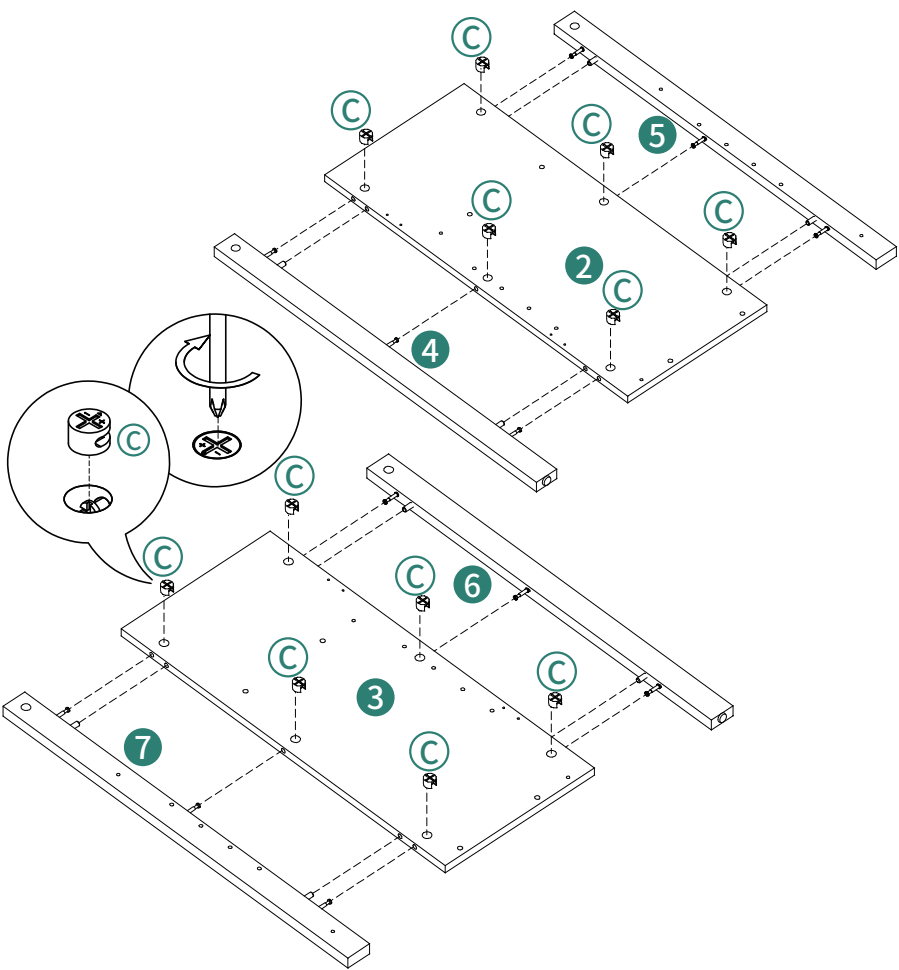

3

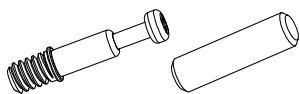

(A) 8PCS

(B) 8PCS

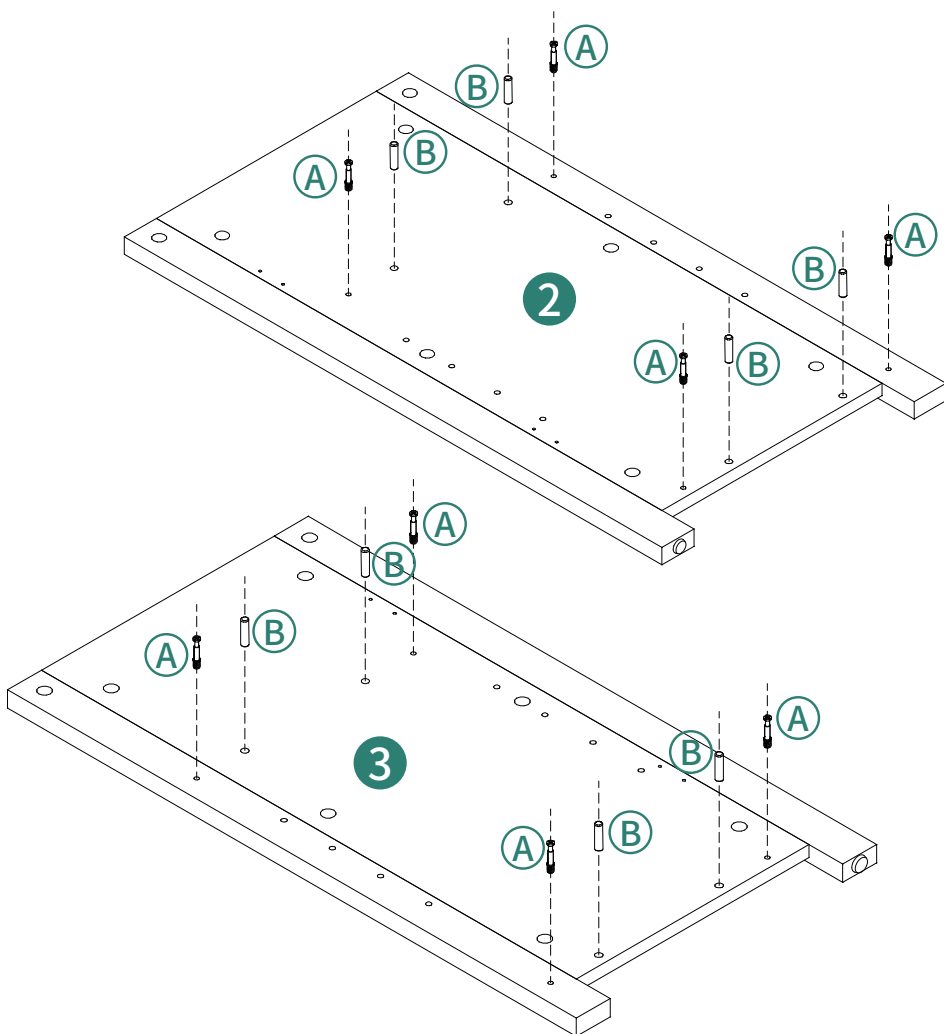

4



⑨ 1PCS



⑪ 1PCS

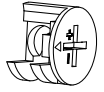

Ⓒ 8PCS

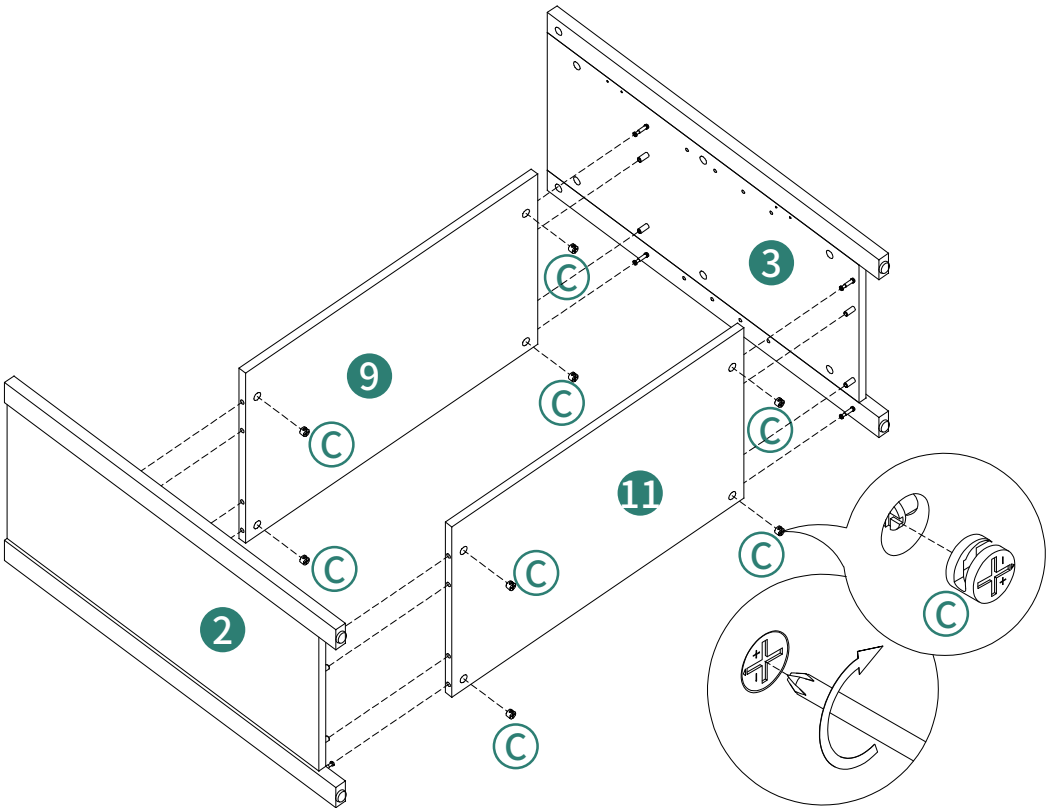

5

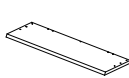

① 1PCS

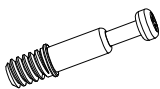

A 4PCS



B 4PCS



C 4PCS

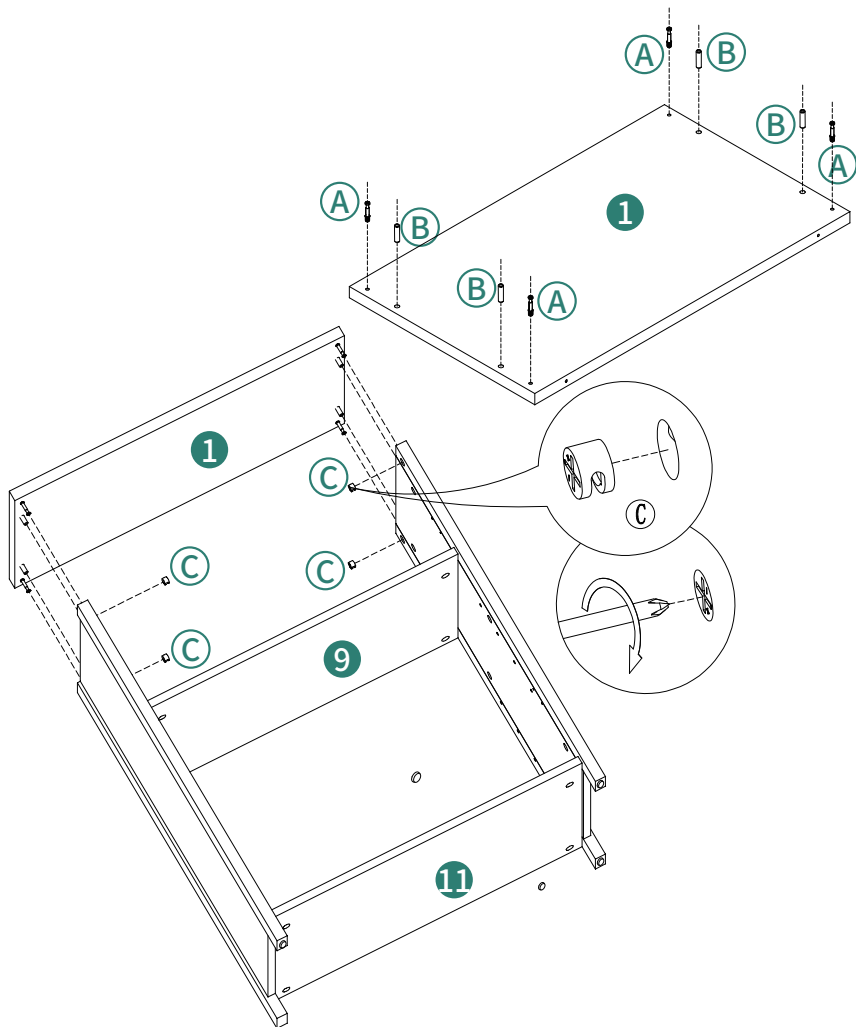

6

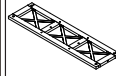

17 1PCS

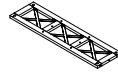

18 1PCS

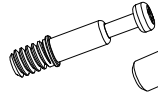

A 12PCS



B 4PCS

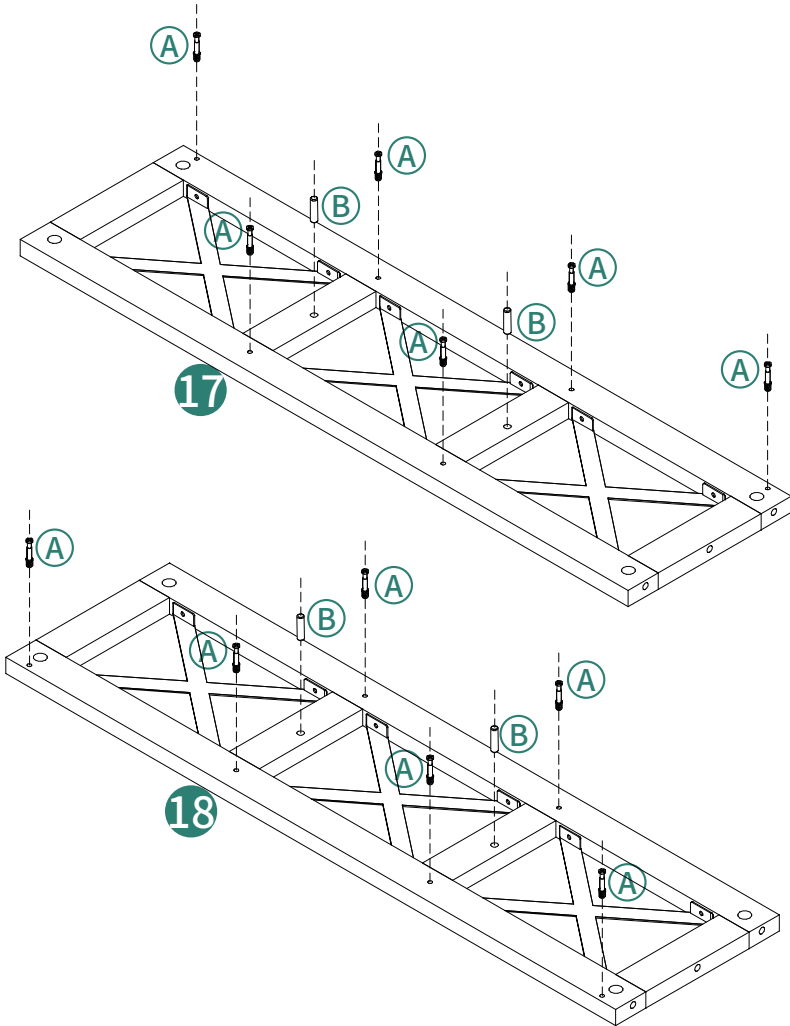

7

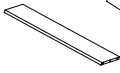

15 2PCS

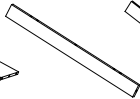

19 1PCS

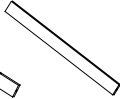

20 1PCS



C 8PCS

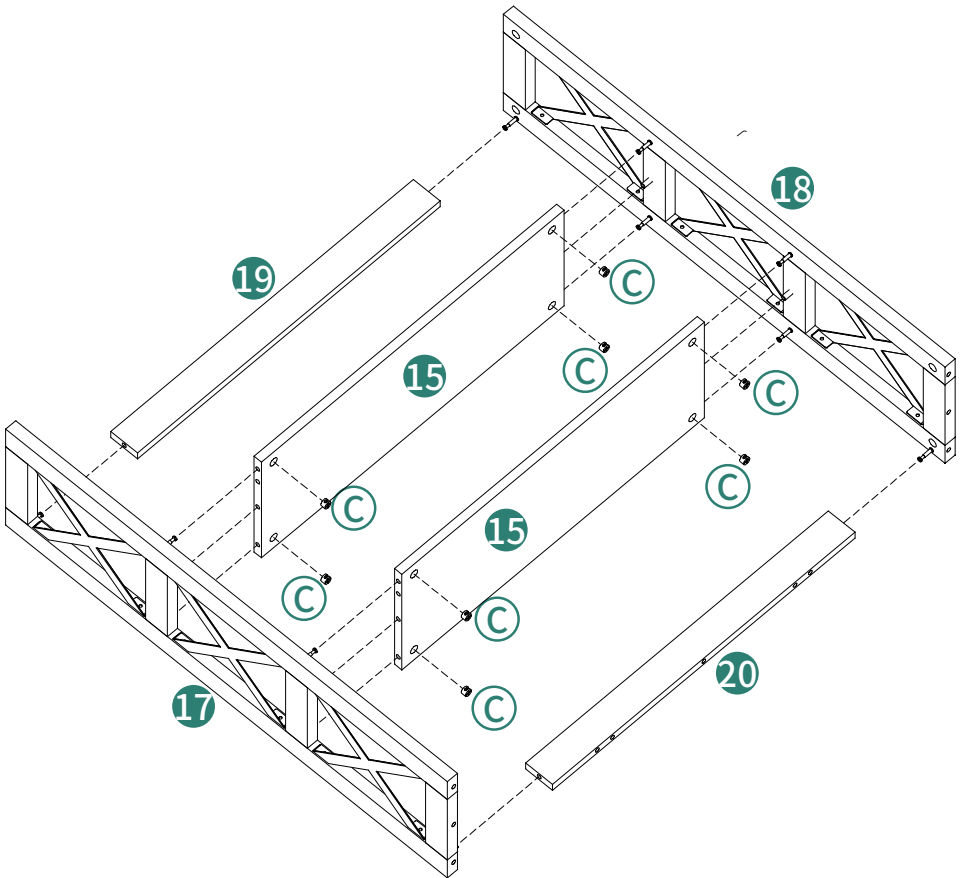

8



© 4PCS

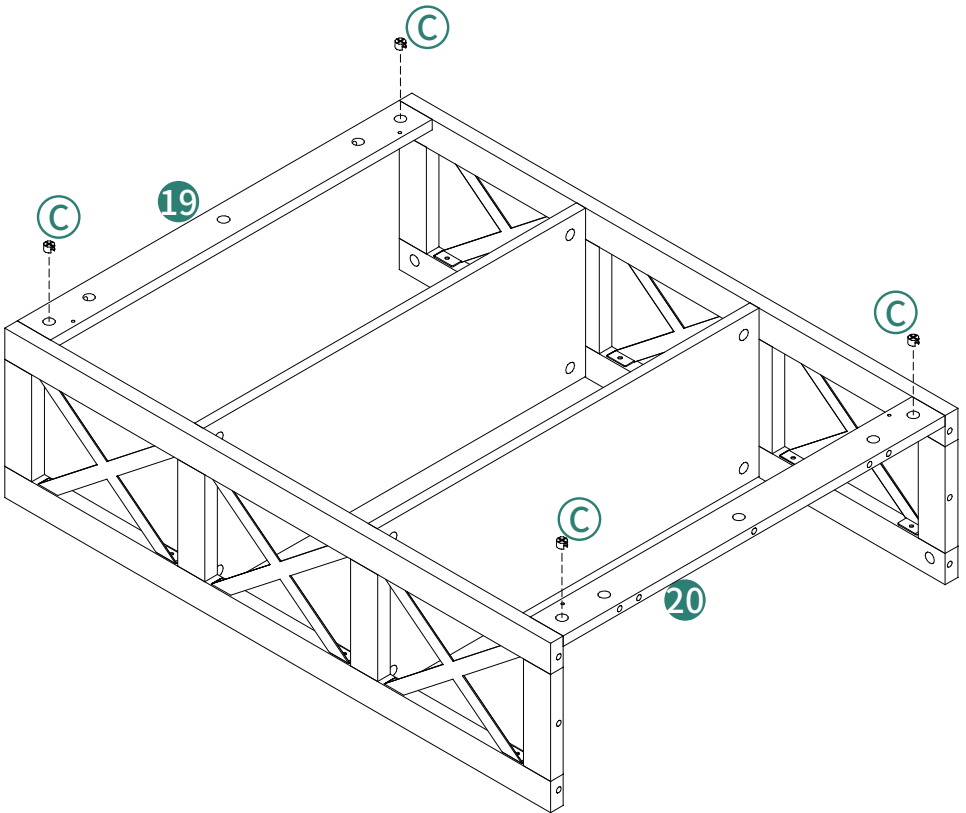

9

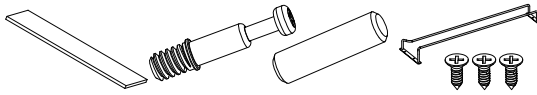

14 1PCS

A 7PCS

B 4PCS

O 1SET

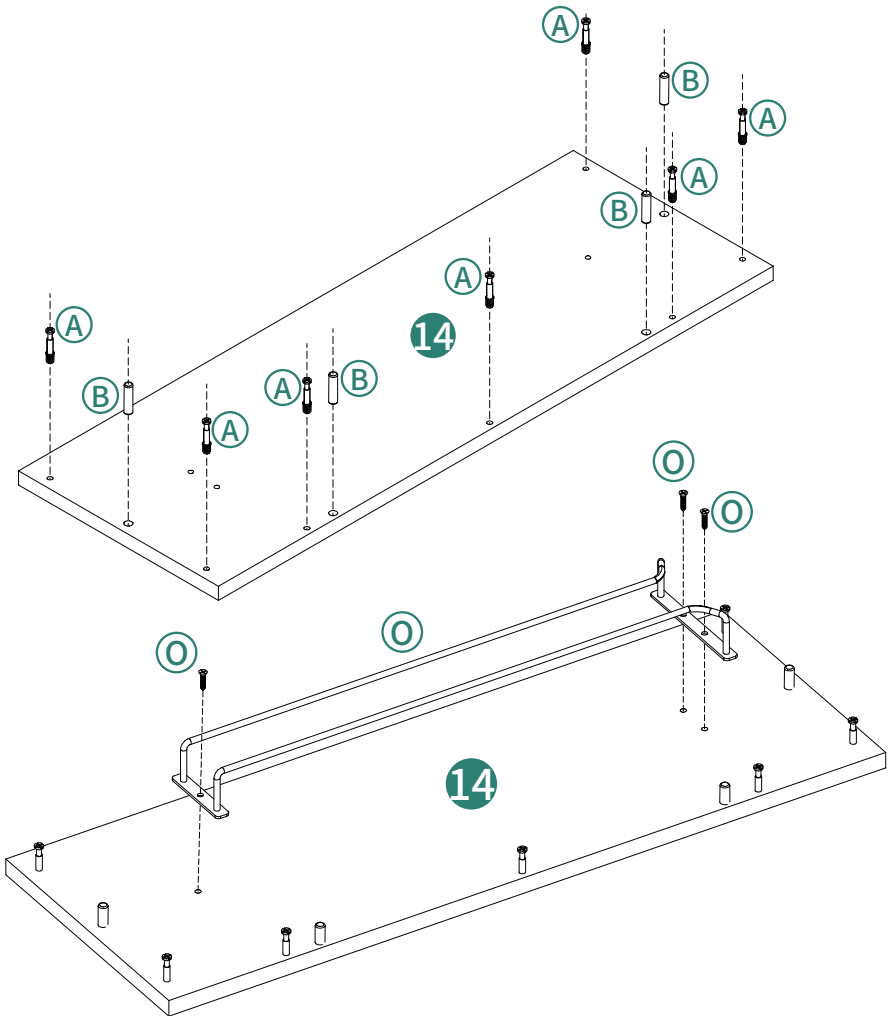

10



© 4PCS

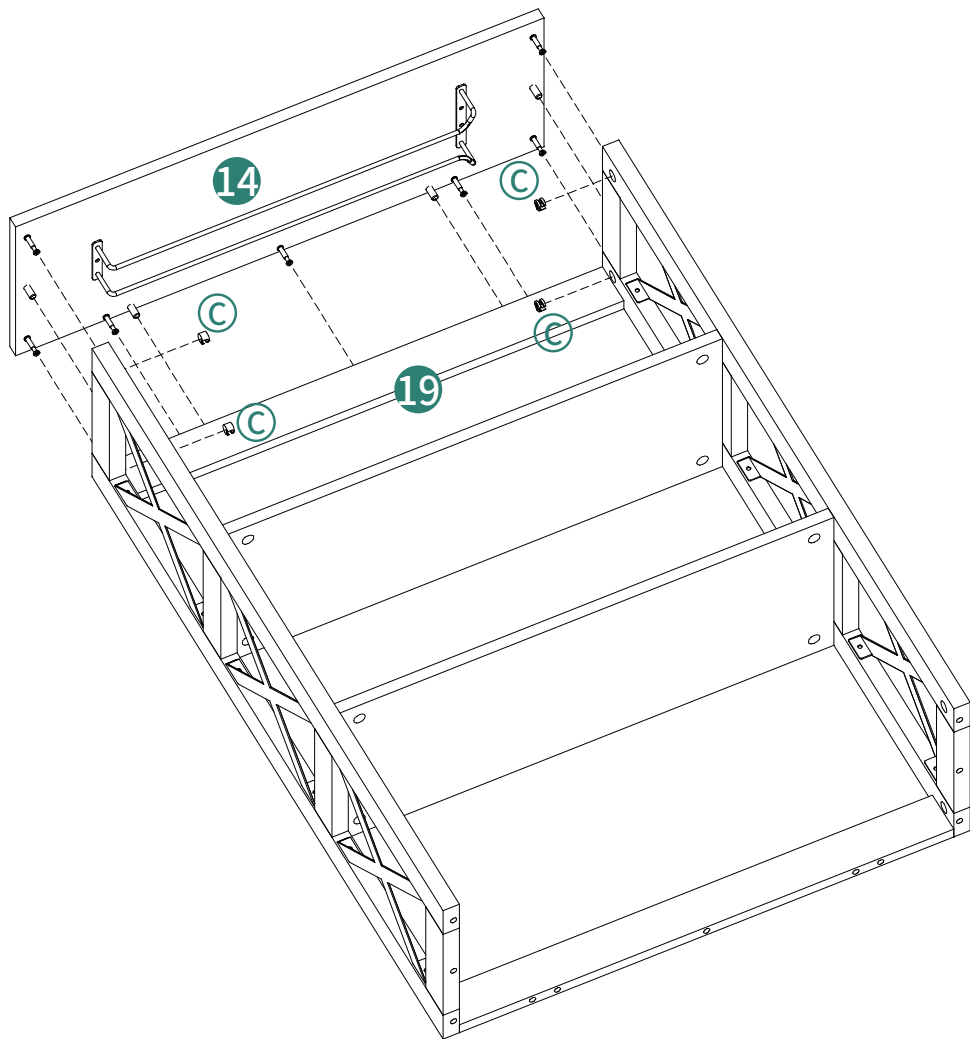

11



© 3PCS

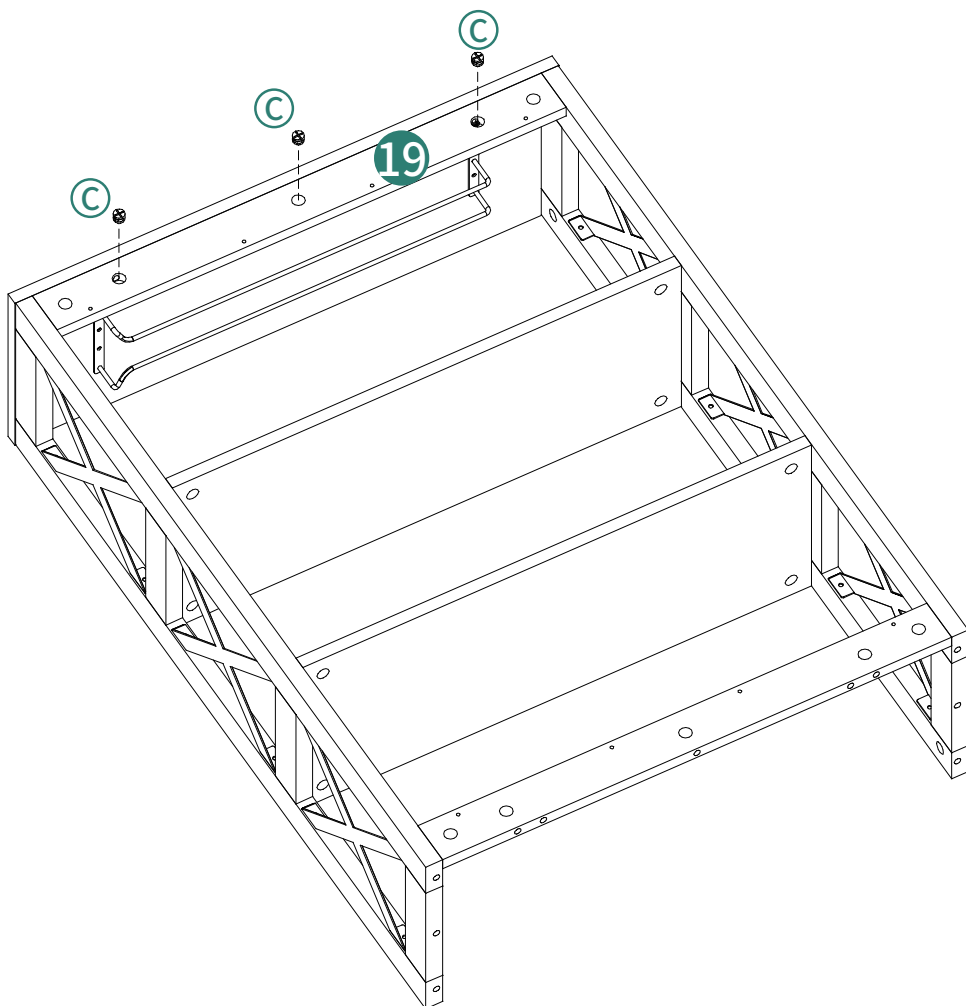

12

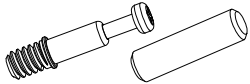

(A) 7PCS

(B) 4PCS

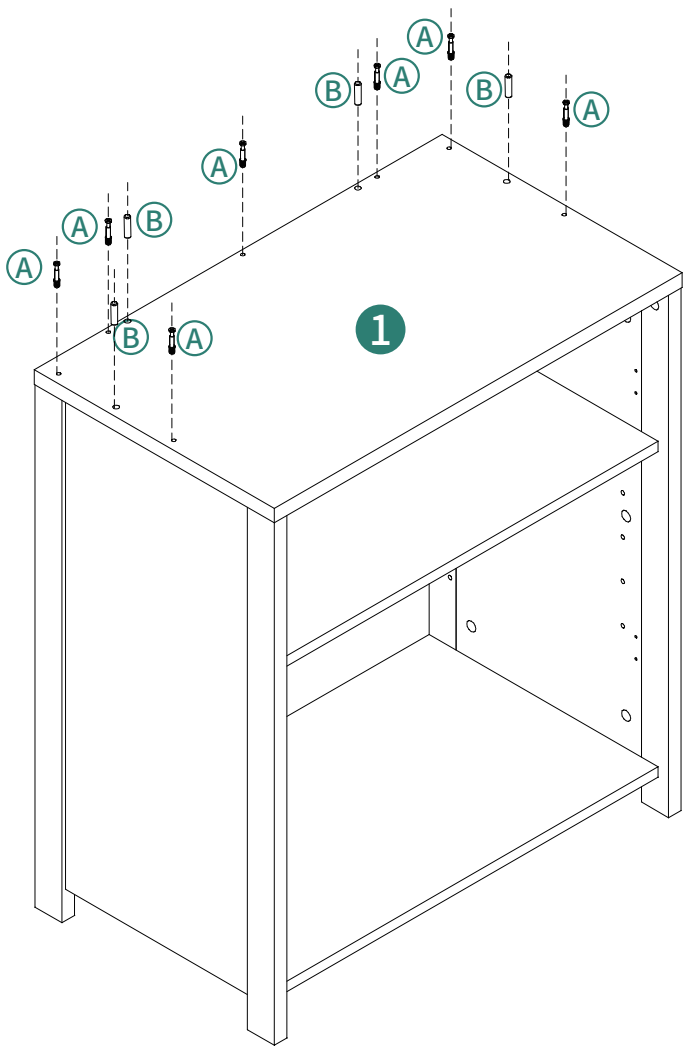

13



© 7PCS

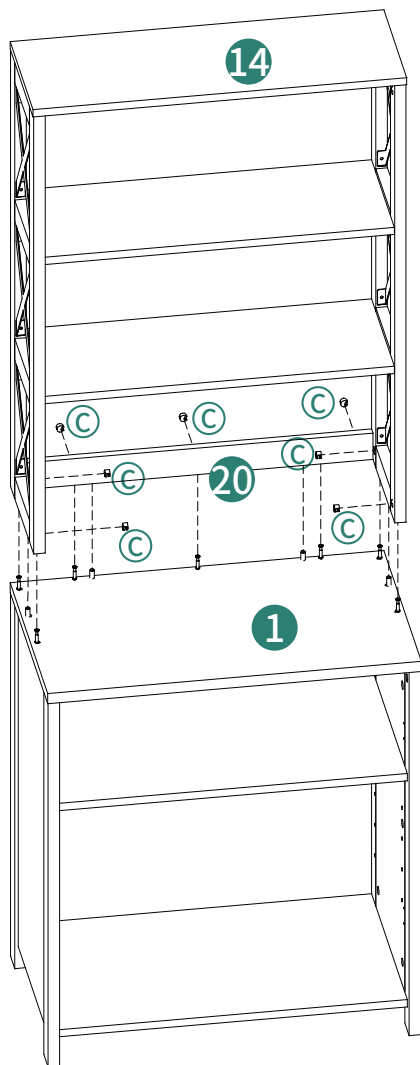

14



⑧ 1PCS



⑩ 1PCS

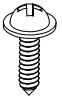

Ⓜ 40PCS

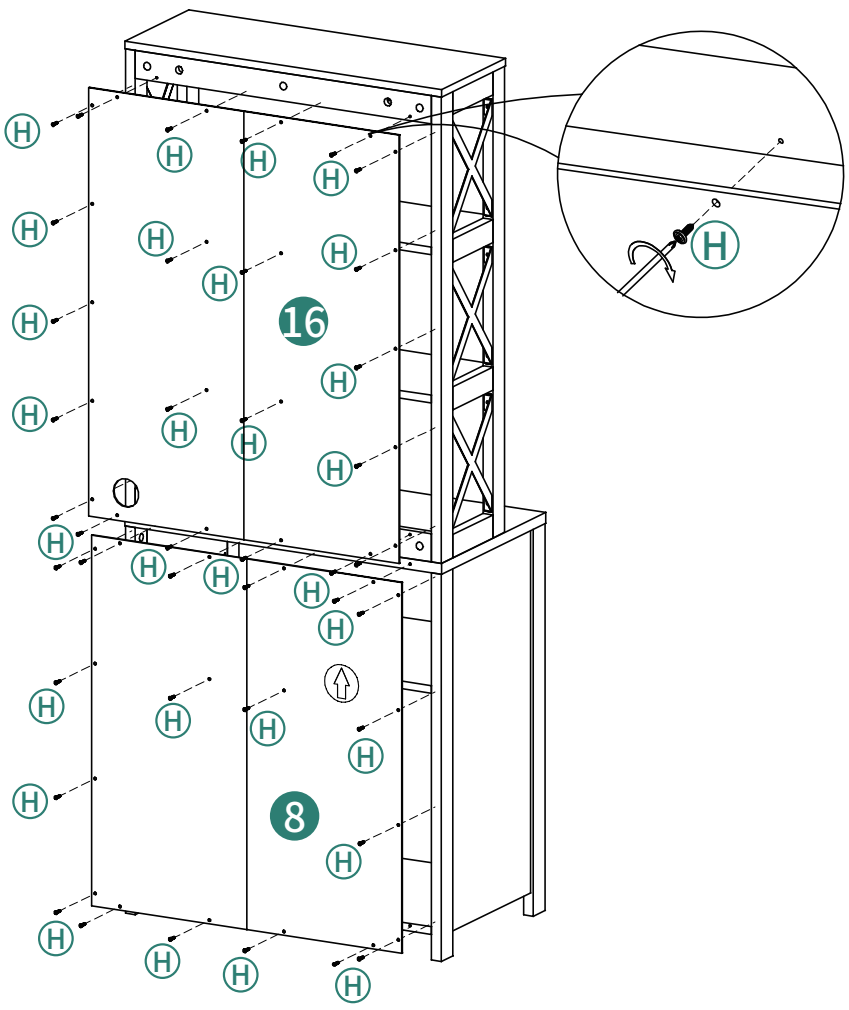

15

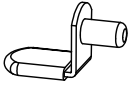

G 4PCS



J 46PCS

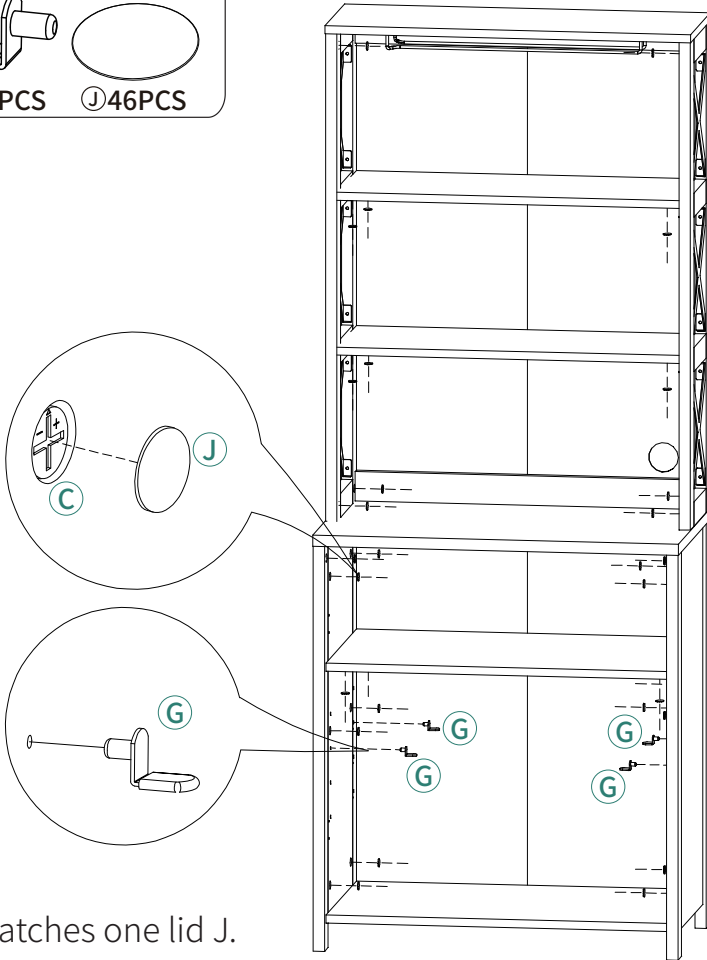

Each disc C matches one lid J.

Jede Scheibe C passt zu einem Deckel J.

Chaque disque C correspond à un couvercle J.

Ogni disco C corrisponde a un coperchio J.

Cada disco C coincide con una tapa J.

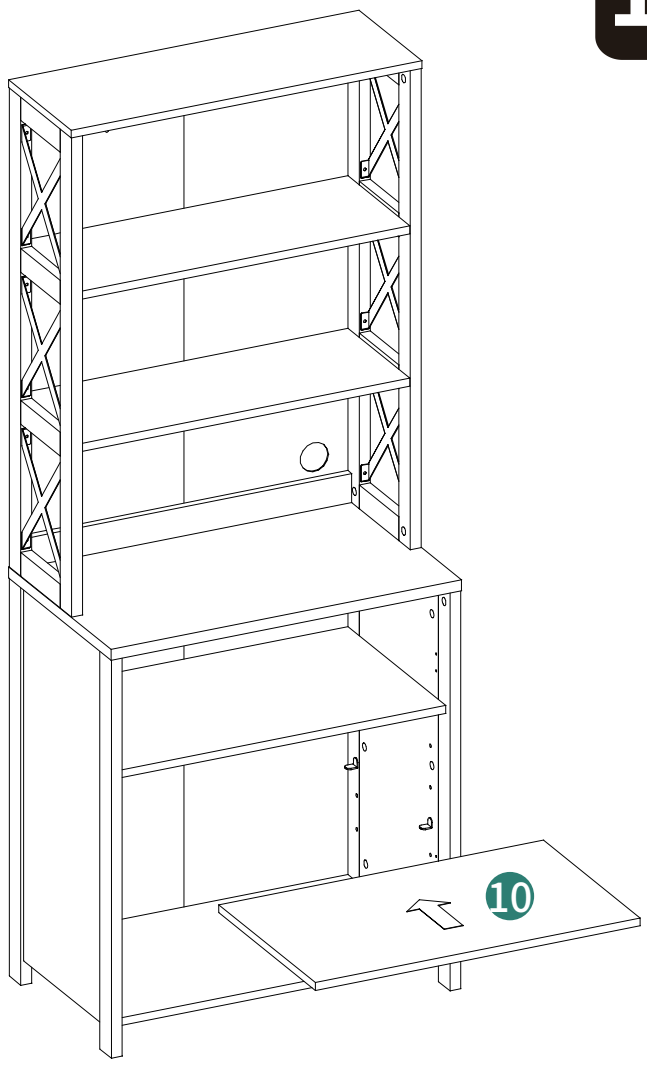

16	 ⑩ 1PCS
-----------	----------------------------------------------------------------------------------------------

17

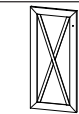

12 1PCS



13 1PCS

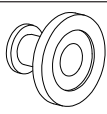

E 2PCS

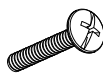

F 2PCS



I 8PCS



D 4PCS

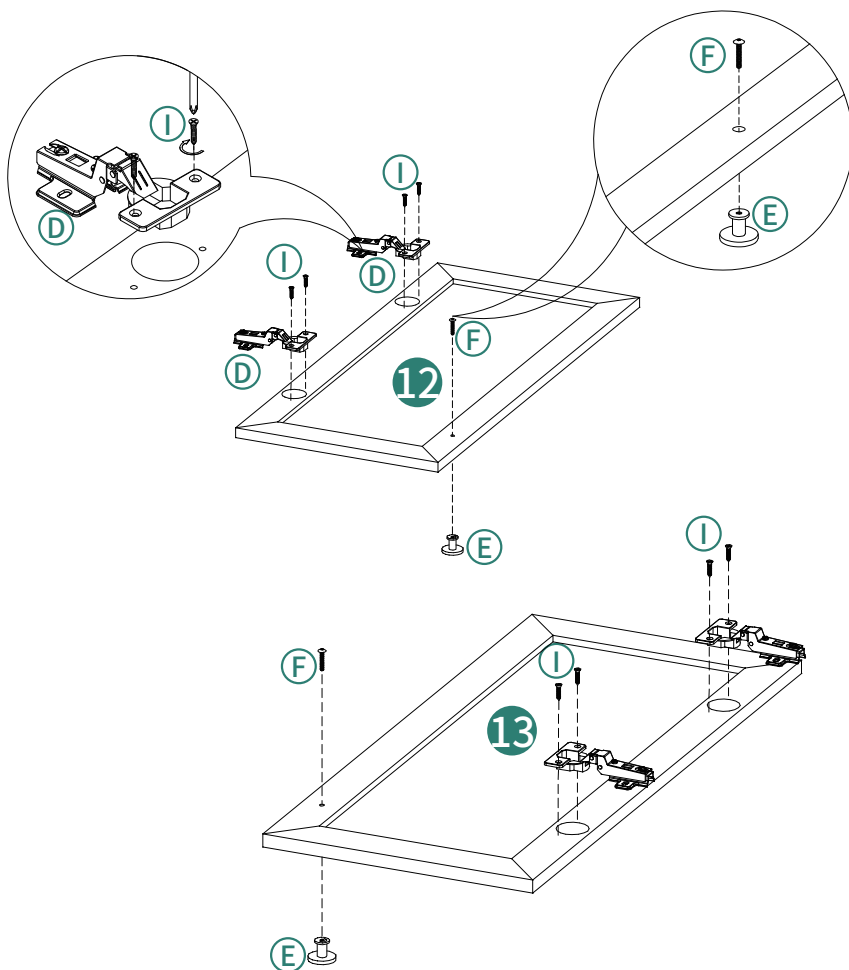

Firstly install the lower hinge D, and then install the upper one to keep doors upright.

Montieren Sie zuerst das untere Scharnier D und dann das obere Scharnier ein, um die Türen aufrecht zu halten

Installez d'abord la charnière inférieure D, puis installez celui du haut pour maintenir les portes droites.

Installare prima la cerniera inferiore D e poi quello superiore, mantenendo le porte in posizione verticale.

Primero, instale la bisagra inferior D, y luego instale la superior para mantener las puertas en posición vertical.

18



① 8PCS

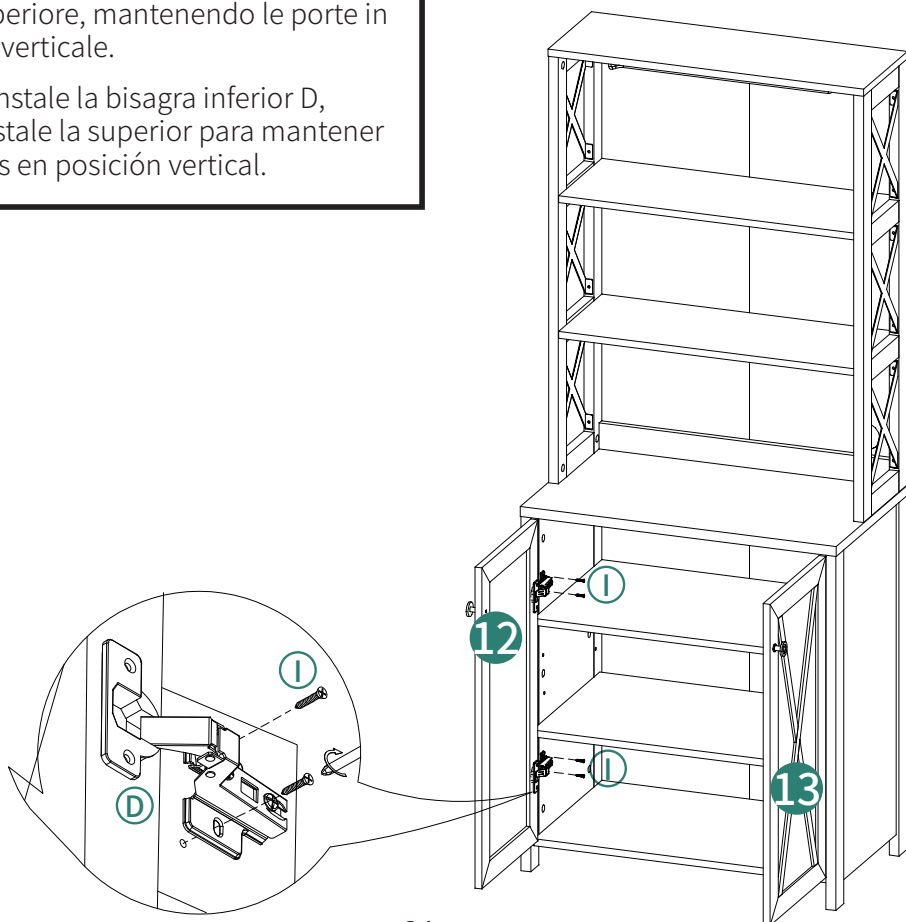

For moving doors forwards/backwards

Zum Bewegen von Türen vorwärts/rückwärts

Pour portes mobiles en avant/en arrière

Porte mobili avanti/indietro

Para mover las puertas hacia adelante/hacia atrás

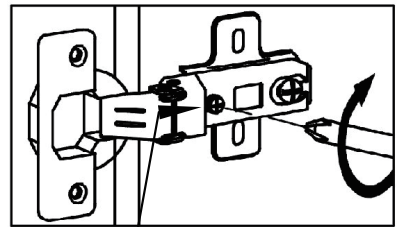
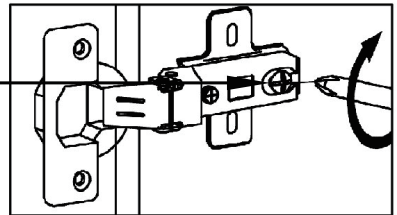

For narrowing/widening doors horizontal spacing

Zum Verengen/Verbreitern Horizontaler Abstand der Türen

Pour rétrécir/élargir espacement horizontal des portes

Per restringere/allargare interasse orizzontale delle ante

Para estrechar/ampliar separación horizontal de las puertas

19 
Ⓜ 2PCS

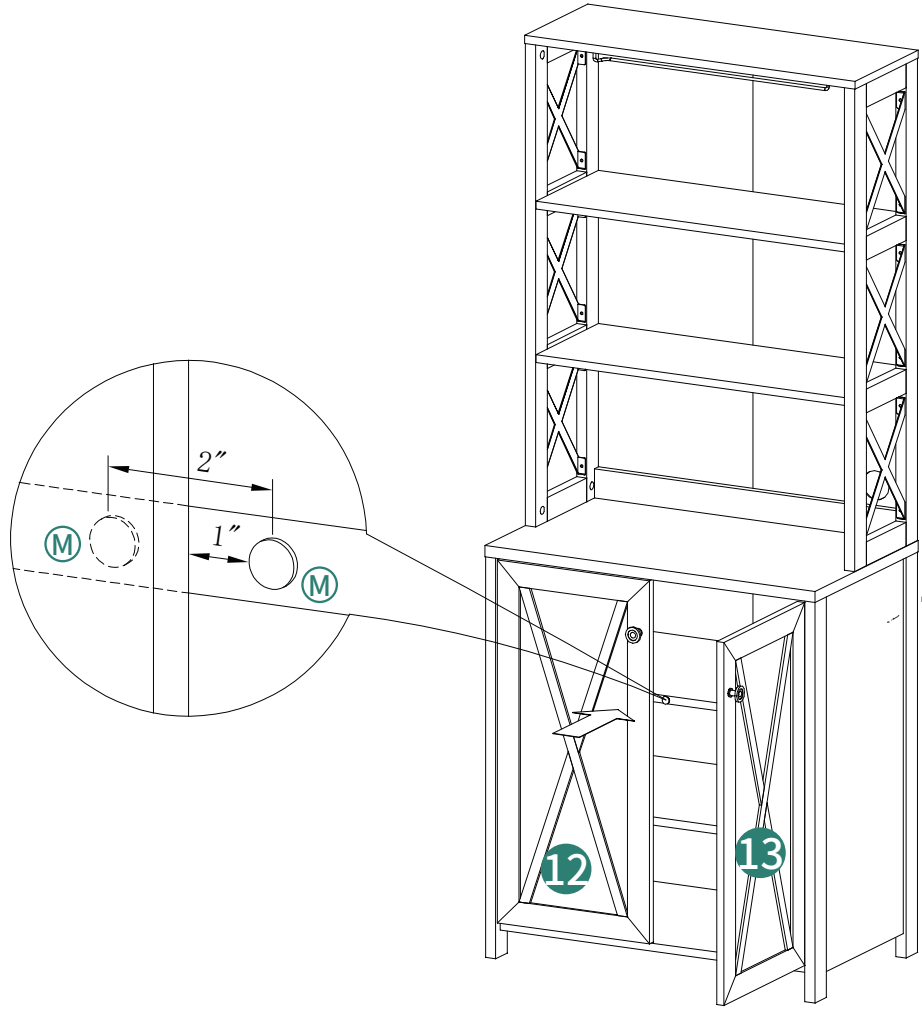

20



(H) 2PCS



(K) 2PCS



(K) 2PCS

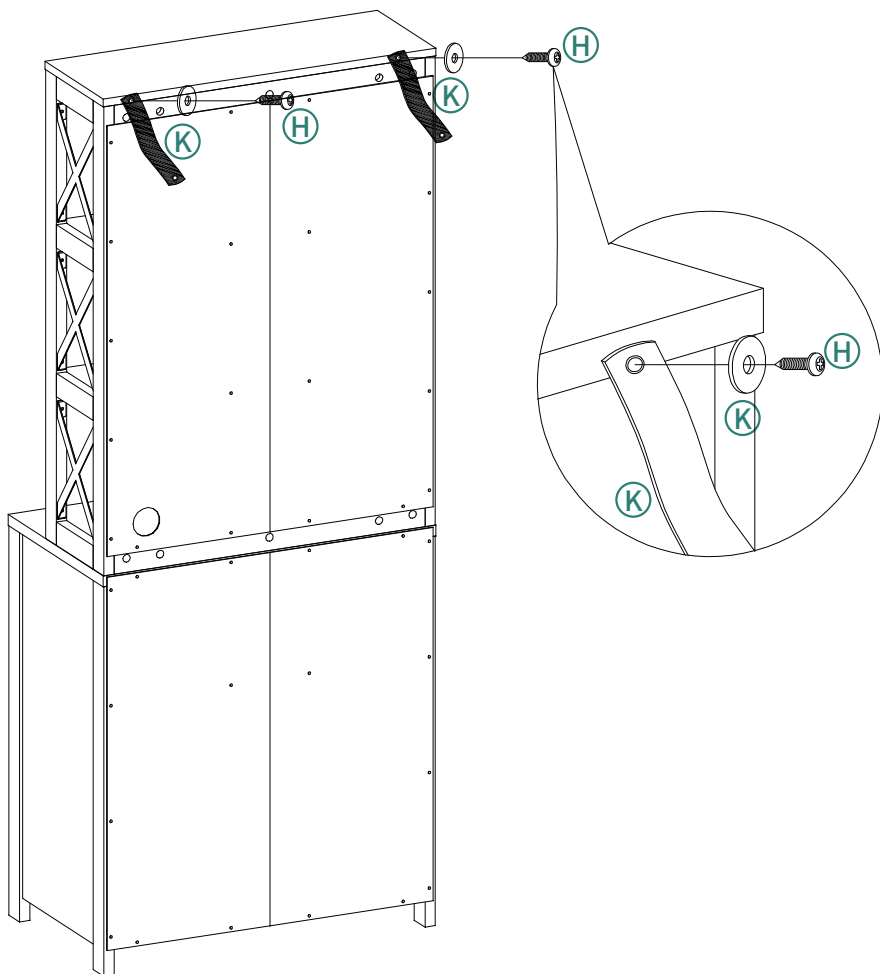

21

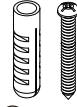

Ⓛ 2PCS



Ⓚ 2PCS

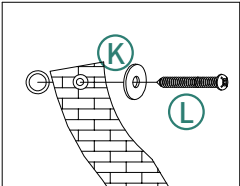
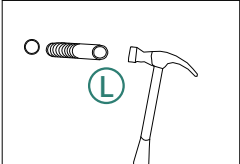
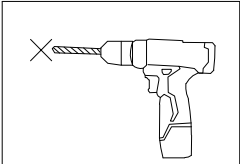
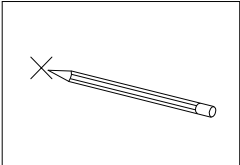

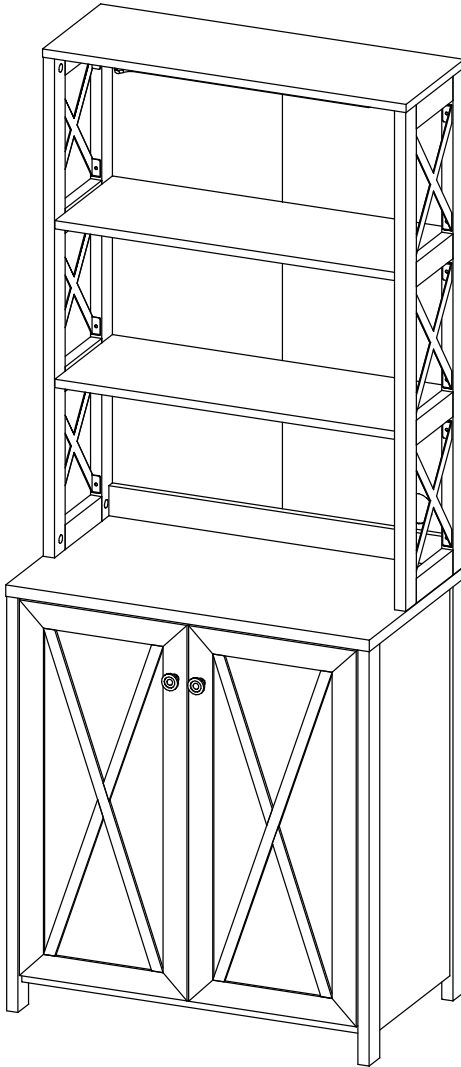

Installation Completed

Installation Abgeschlossen

Installation Complète

Installazione Completata

Instalación Completa