

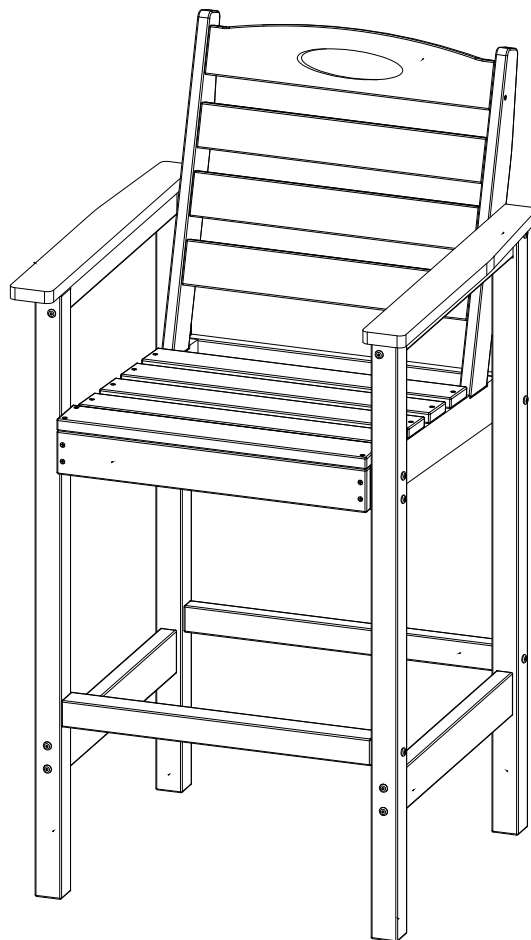

Adirondack Bar Stool

ASSEMBLY MANUAL



MODEL#:LCCZ0710A

Missing part? Damaged? Contact us via email at

service@domioutdoorliving.com

www.domioutdoorliving.com

BEFORE STARTING ASSEMBLY

- ① Please check all parts and components to ensure that there are no damages or missing items BEFORE starting the construction of the product.
- ② For ease of construction, you may need a Power Drill (Cordless, Variable Speed).
- ③ It would be much easier to assemble the product with two or more people.
- ④ Some parts have metal edges. Please be careful when handling components.
- ⑤ Cleaning tips: For a quick clean, simply wipe with soap and water; for a deep clean, use a clean cloth to apply a solution of 1/3 bleach and 2/3 water to the lumber, let it sit for a few minutes (this won't affect the color), then loosen dirt and debris in surface grooves with a soft-bristle brush and rinse with a hose.

IMPORTANT: Please contact Customer Service if you have any problems or discover any missing parts.





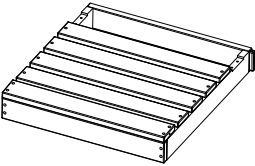
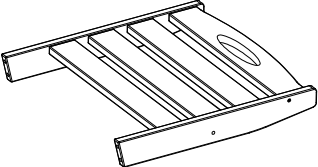
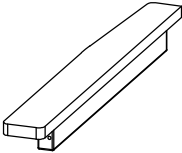
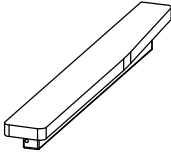
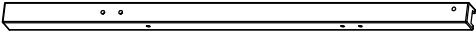
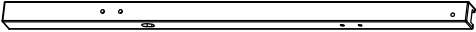
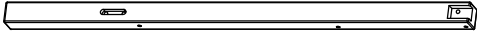
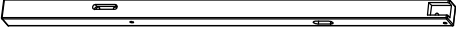
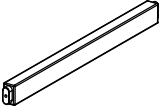
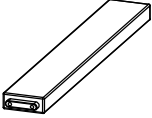

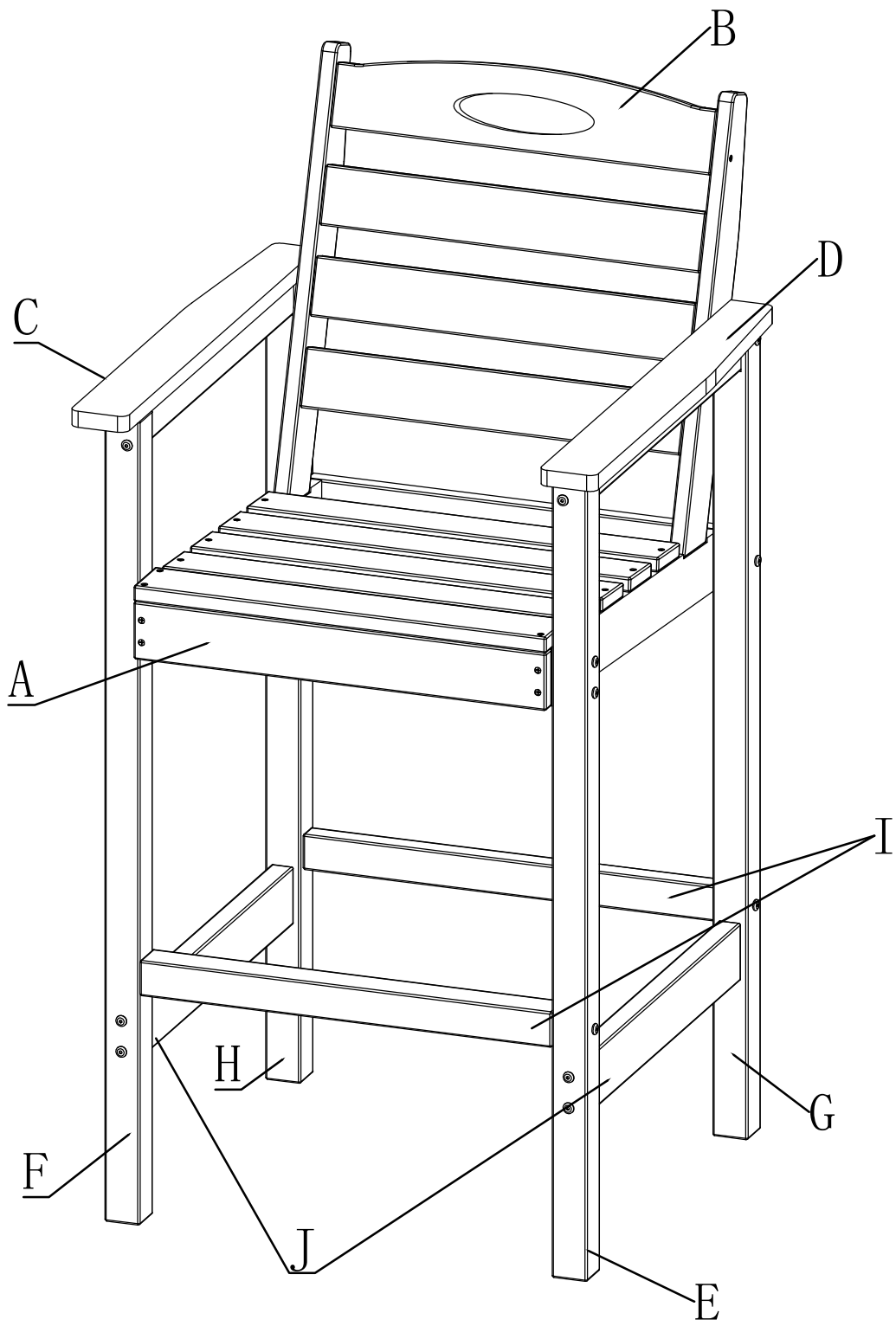

USA & Canada:
1-833-807-3550

A		1
B		1
C		1
D		1
E		1
F		1
G		1
H		1
I		2
J		2

1	 ST6*65	14
2	 M6*70	6
3	 M6	6
4		6
5	 ST6*80	4
6	 ST6*60	4
7		1
8		1

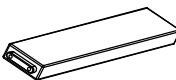

E		X1
F		X1
G		X1
H		X1
J		X2
①		ST6*65 X8

Step1

Attach Braces #J to Leg #F and Leg #H with Screws #1. Repeat the another side. Pre-drilled holes indicate screw placement only. Fully thread screws into material for full engagement.

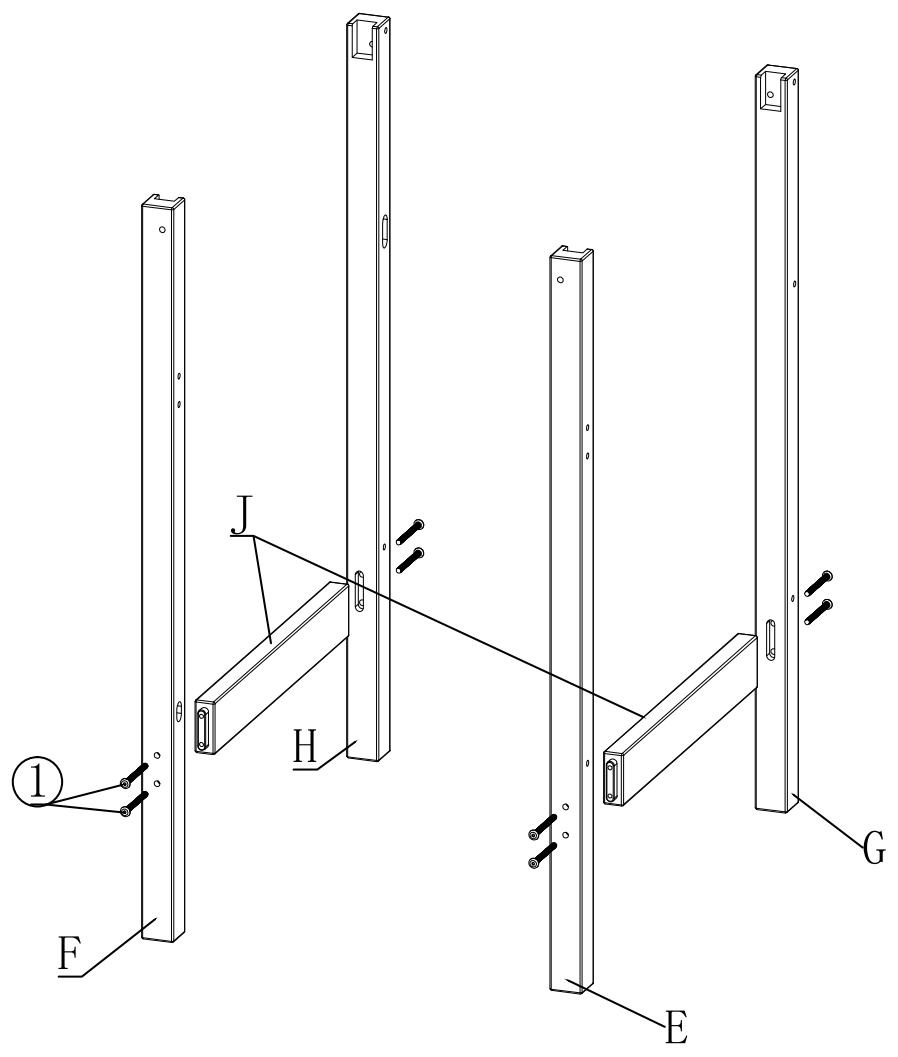

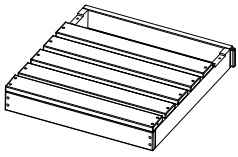
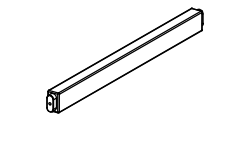
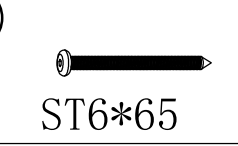
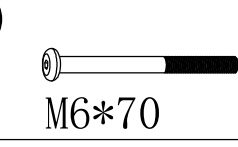
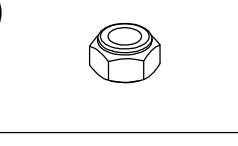
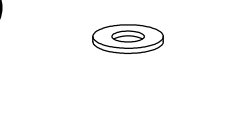
A		X1
I		X2
①	 ST6*65	X3
②	 M6*70	X2
③		X2
④		X2

Step2

(1) Attach each Brace #I to Leg #F and Leg #H using one Screw #1 per side.

(2) Attach the Seat Slats #A to the assembled structure. Use 2 Bolts #2, 2 Washers #4, and 2 Nuts #3 on one side, and use 1 Screw #1 on the other side.

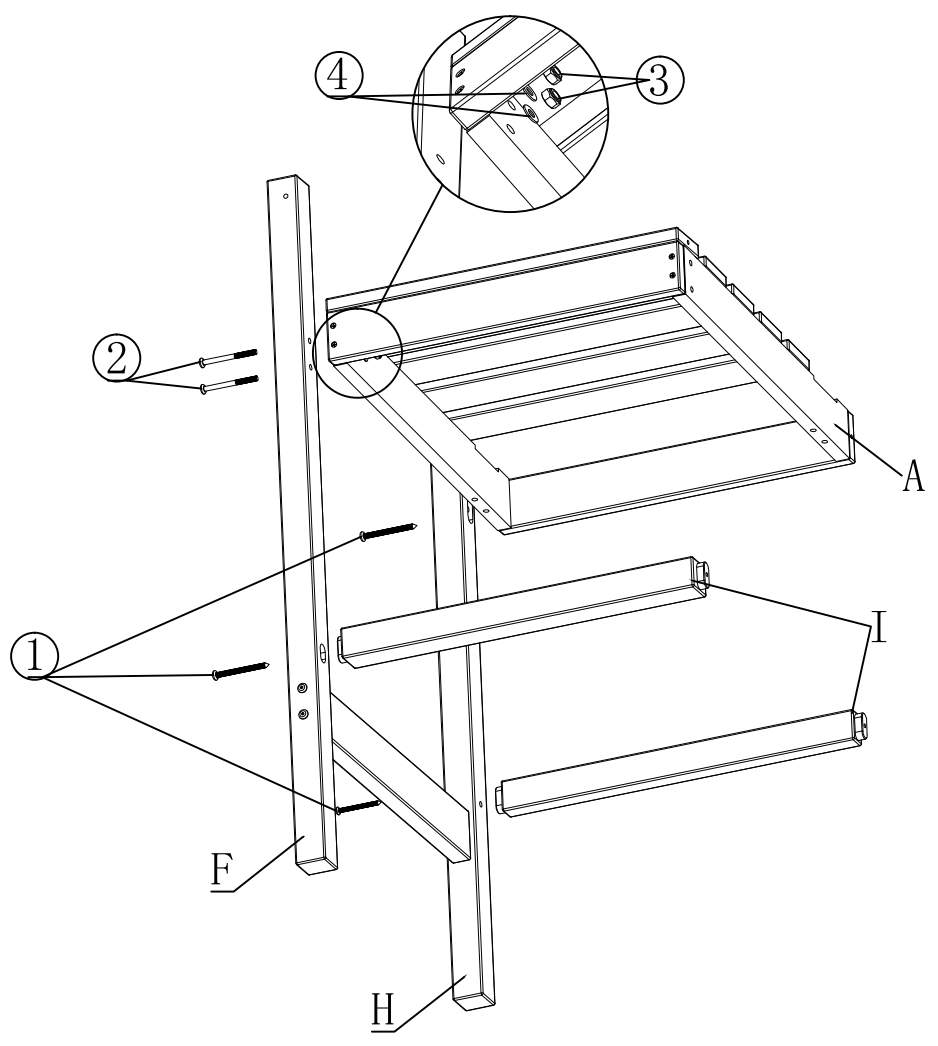

①



ST6*65 X3

②

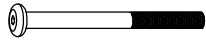

M6*70 X2

③



M6 X2

④



X2

Step3

Attach Leg #E, Leg #G, and Brace #J to the assembled structure using the following hardware: Upper-left connection: 2 Bolts #2, 2 Washers #4, and 2 Nuts #3. Other three sides: 1 Screw #1 each.

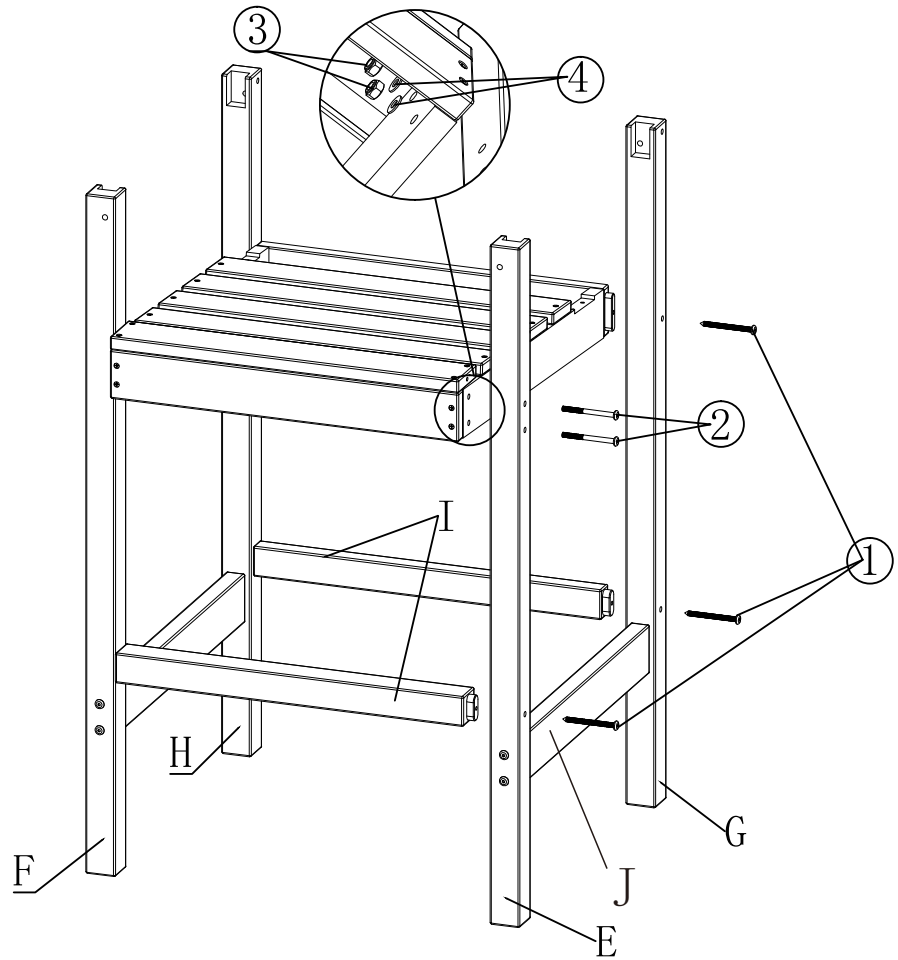

C

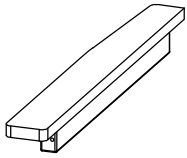

X1

D

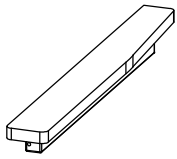

X1

⑥



ST6*60

X4

Step4

Attach Armrest Part #D and Armrest Part #C to the 4 legs using 1 Screw#6 per leg (4 screws in total).

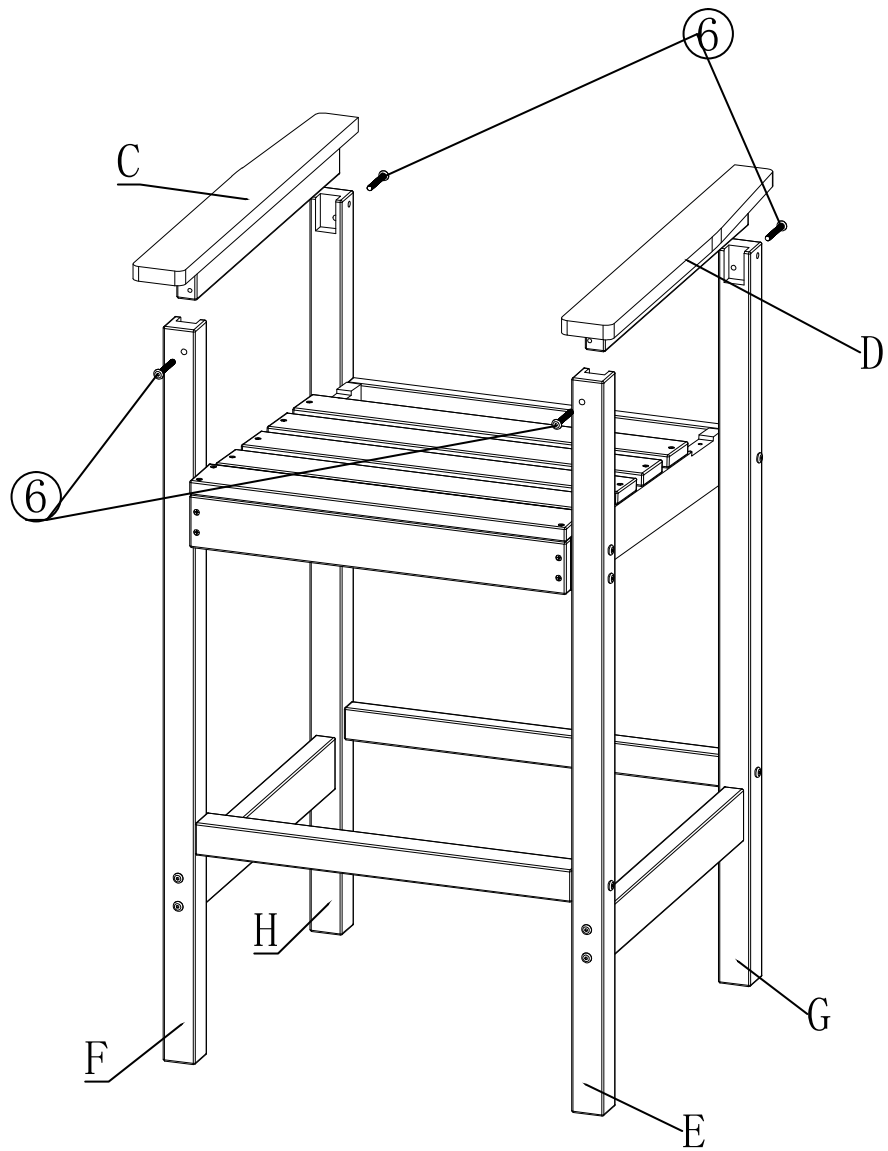

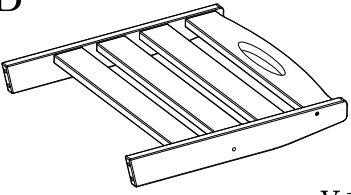
B

X1

②

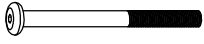

M6*70

X2

③



M6

X2

④



X2

⑤



ST6*80

X4

Step5

Attach Backrest Slats #B to the frame. On each side of the backrest: 2 Screws #5, 1 Bolt #2, 1 Washer #4, and 1 Nut#3.

Align the holes and assemble Bolts#2 first.

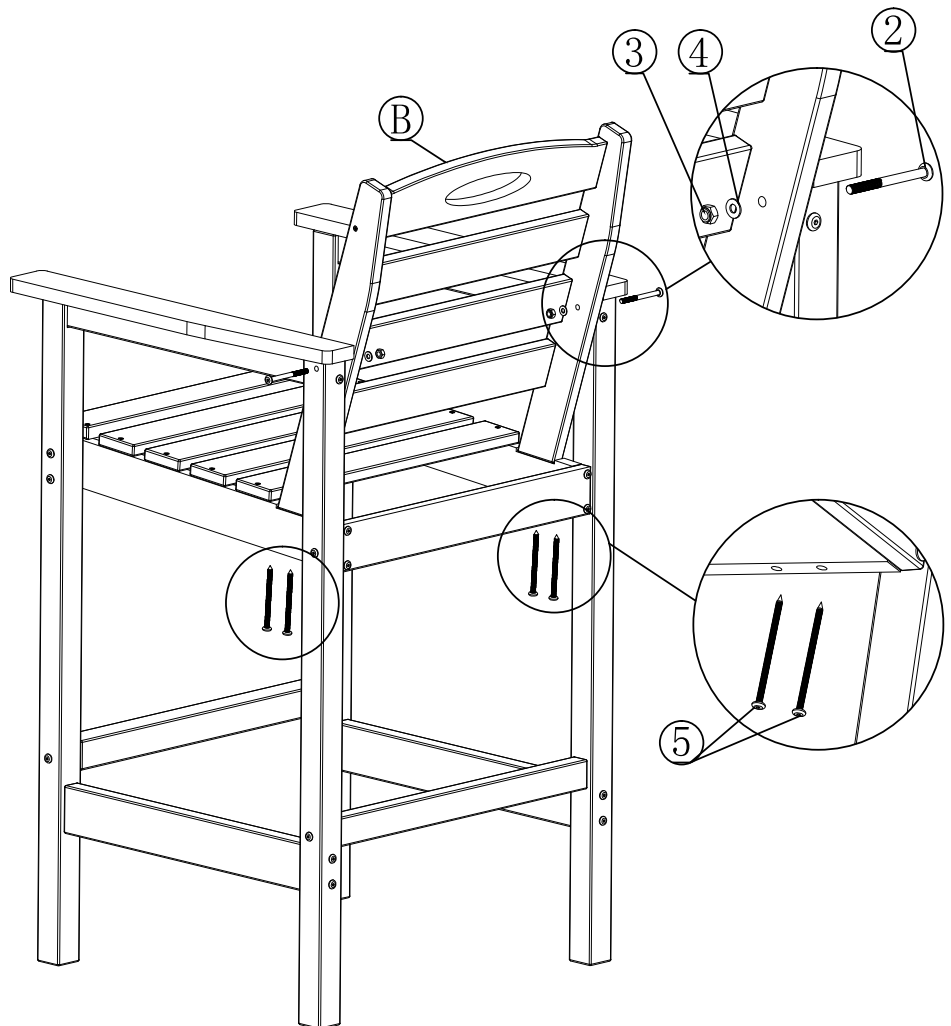



Thanks for your purchase.

At domi outdoor living, we believe in our products.

That's why we provide a 12-month warranty and friendly, easy-to-reach after-sales service. So, if you have any questions about our product or assembly, please feel free to contact us. We are here for you.

Support:  

After-sales contact email:

service@domioutdoorliving.com

Business cooperation contact email:

marketing@domioutdoorliving.com

Please have your order ID available if you reach out for support.

If you have damaged parts or product, please send us photos for an immediate response.