

## Patio Set

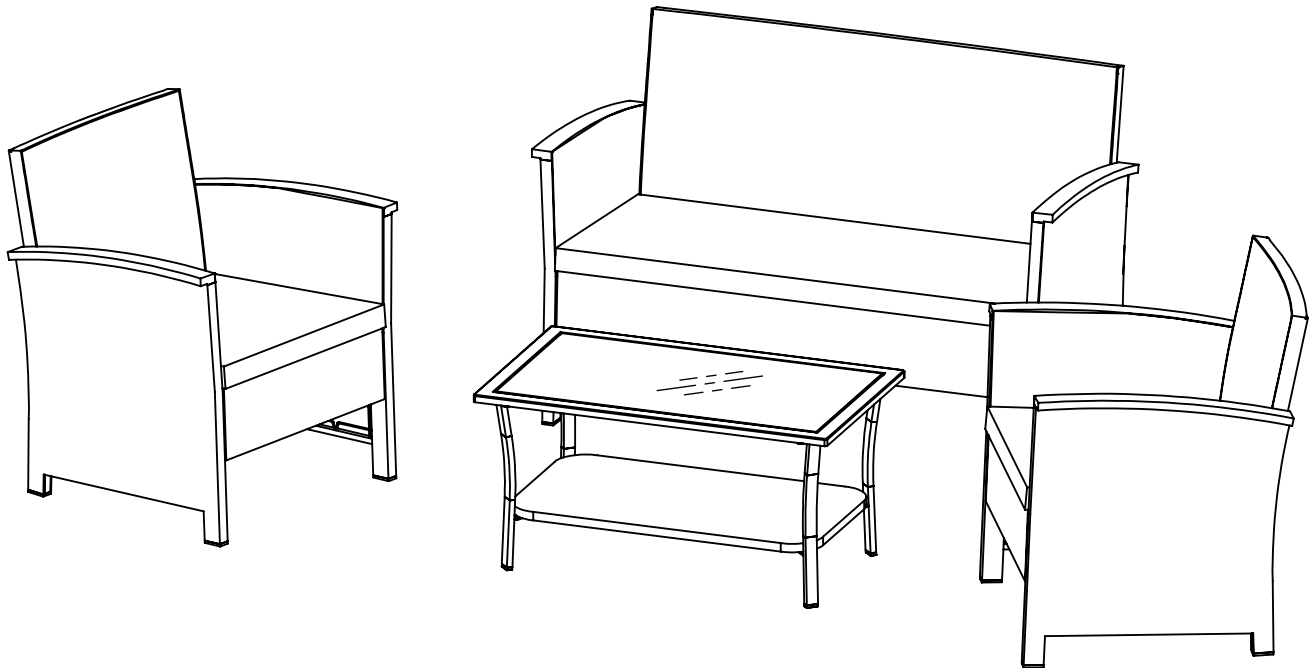

### ATTACH YOUR RECEIPT HERE

Keep a copy of your proof of purchase or order confirmation which will be needed if you need to contact us about warranty coverage.

Purchase Date: \_\_\_\_\_



### SAVE THESE INSTRUCTIONS FOR FUTURE REFERENCE.



### Questions, problems, missing parts?

Before returning to your retailer, our exceptional customer service is available. Call us toll-free , email us, or go online and live chat .



## BEFORE YOU BEGIN

Before beginning assembly, make sure all parts are present. Compare parts received with the parts list. If any part is missing or damaged, do NOT attempt to assemble the product. Please read and understand this entire manual before attempting to assemble, operate or install this product. If you have any questions regarding the product, please call us toll-free , email us , or go online and live chat.



## GENERAL INFORMATION

Your new Patio Set is made from the finest materials available. It should provide years of enjoyment with minimal care.

Keep your Patio Set clean. For best results, clean with a soft, damp cloth. You may use a standard glass cleaning spray to clean the glass tabletop. If you use furniture covers, always make sure the Patio Set is clean and completely dry before covering, as mold may form in dark, wet places. Remove cushions prior to covering and store them in a dry, temperature controlled place. Check the hardware on your Patio Set regularly to make sure it is secure.

The weight limit is 220 lb/100kg per chair, 440 lb/200kg total for sofa.



## SAFETY INFORMATION

### WARNING

Do not stand or allow children to stand on the assembled product. Ensure hardware is securely in place. Perform periodic checks to make sure the connections are secure and adjust if needed. The glass tabletop is tempered for strength but may break or chip if dropped, struck sharply, or otherwise abused. Do not sit or stand on the glass tabletop, and take reasonable precautions to avoid injury in the event of glass breakage.

### CAUTION

Read all instructions before beginning assembly. Failure to do so may result in faulty assembly and potential injury. Assemble the item on a soft, non-abrasive surface such as carpet or cardboard to avoid damaging the item.

## PARTS LIST - PER CHAIR (A & B)

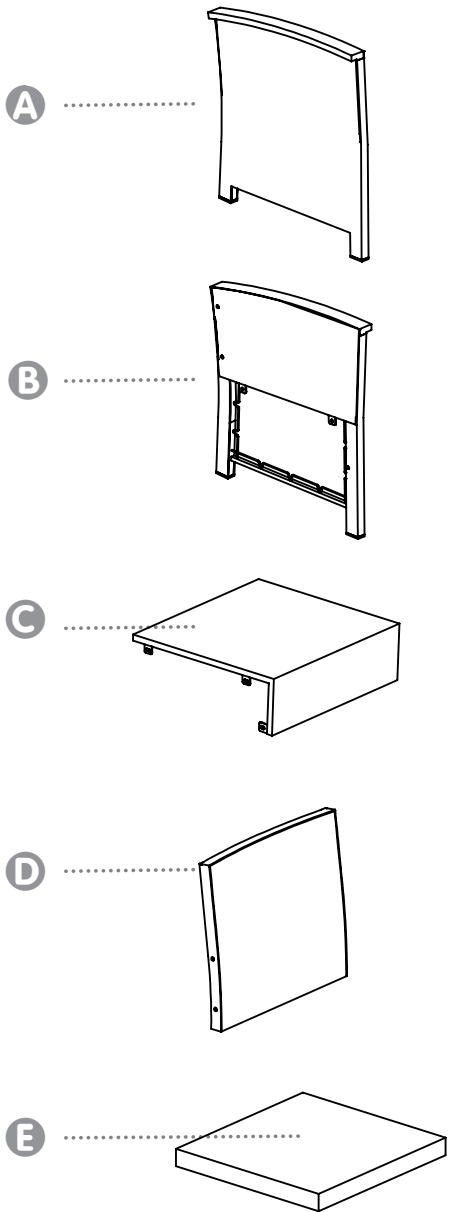

PART	DESCRIPTION	QUANTITY
A	Left* Side Panel	1
B	Right* Side Panel	1
C	Seat Panel	1
D	Back Panel	1
E	Seat Cushion	1

*\*When facing the front of the chair*



## HARDWARE CONTENTS



**F**  
M6x25 Bolt  
Qty: 6



**G**  
M6x35 Bolt  
Qty: 4



**H**  
Washer  
Qty: 10



Hex Key

Assemble in a clear area on a spacious, nonabrasive surface such as a carpet or blanket. Wait to fully tighten hardware until final step. Do not over-tighten hardware.

# ASSEMBLY - CHAIR (A & B)

- 1** Locate the **Right Side Panel (B)** and **Seat Panel (C)**. Place a **Washer (H)** on each of 3 **Bolts (F)**. Align the panels as shown. Insert each **Bolt with Washer** through the eyelets in the **Seat Panel** and into the holes in the edge of the **Right Side Panel**.

Tighten using the **Hex Key**, but do not over-tighten.



Hardware Used:

**F Bolt (M6x25) x3**

**H Washer x3**

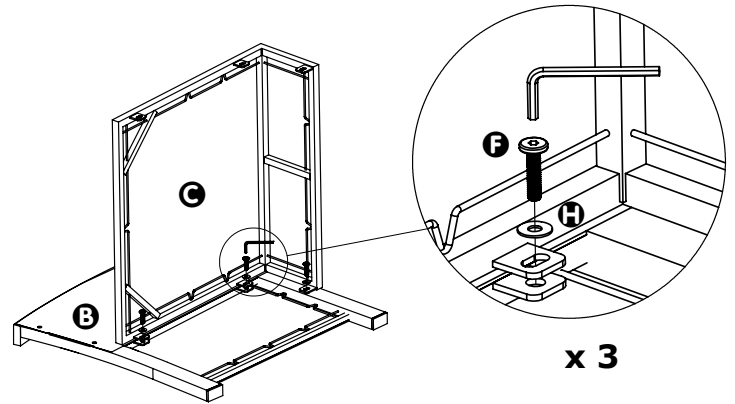

- 2** Attach the **Back Panel (D)** to the **Right Side Panel (B)**: Place a **Washer (H)** on each of 2 **Bolts (G)**. Align the eyelets on the **Back Panel** with the holes in the **Right Side Panel** as shown, then insert a **Bolt with Washer** into each of the 2 aligned sets of eyelets.

Tighten using the **Hex Key**, but do not over-tighten.



Hardware Used:

**G Bolt (M6x35) x2**

**H Washer x2**

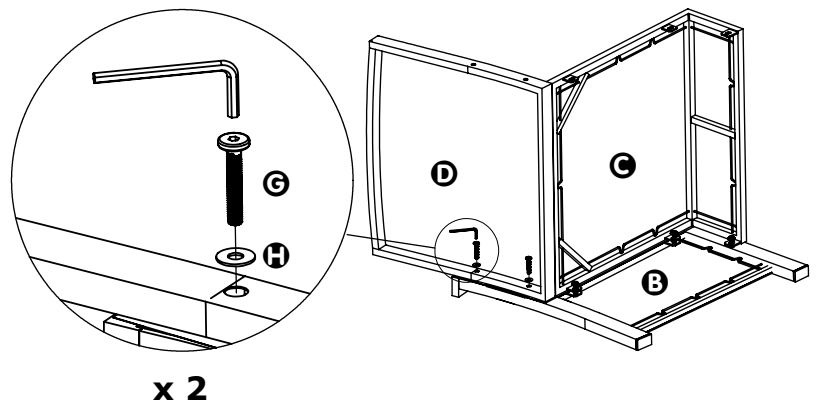

- 3** Locate the **Left Side Panel (D)**. Place a **Washer (H)** on each of 2 **Bolts (G)**. Place the partially-assembled chair on the **Left Side Panel** as shown. Align the eyelets on the **Back Panel** with the holes in the **Left Side Panel** and insert a **Bolt with Washer** through each of the 2 aligned sets of eyelets.

Tighten using the **Hex Key**, but do not over-tighten.



Hardware Used:

**G Bolt (M6x35) x2**

**H Washer x2**

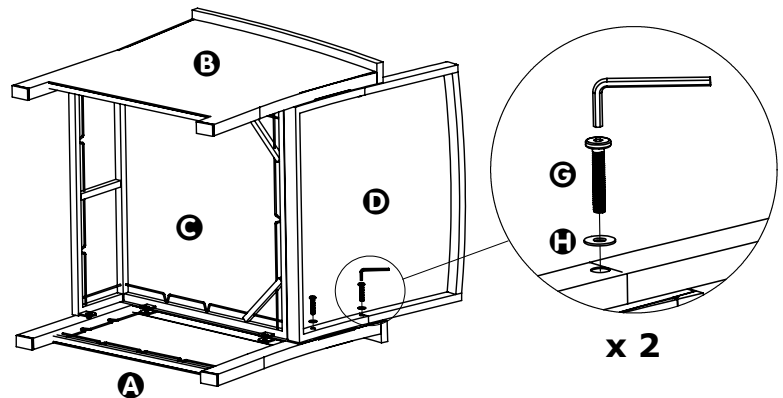

## ASSEMBLY - CHAIR (A & B)

**4** Place a **Washer (H)** on each of 3 **Bolts (F)**. To attach the **Left Side Panel (C)** to the **Seat Panel (B)**, insert a **Bolt** with **Washer** into the 3 aligned sets of eyelets.

Tighten Bolts using the **Hex Key**, but do not over-tighten.

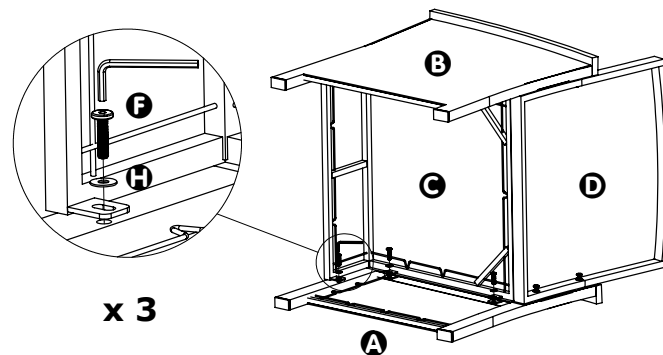

Hardware Used:

**F** Bolt (M6x25) x3

**H** Washer x3

**5** Turn assembled chair upright on a flat, level surface to ensure that it sits squarely and level on the ground. Adjust fastenings if needed, then firmly tighten all **Bolts**.

Place the **Seat Cushion** in the seat.

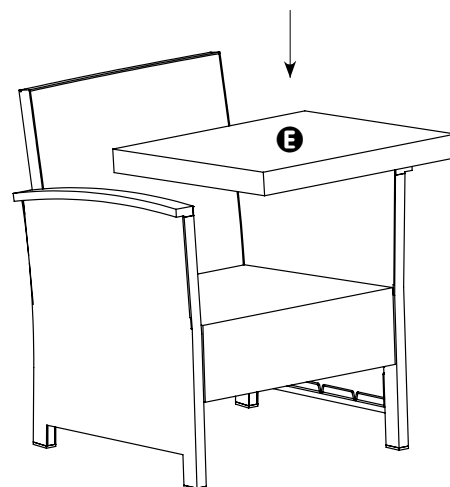

Your Chair is fully assembled!

Repeat these steps to assemble the second chair.

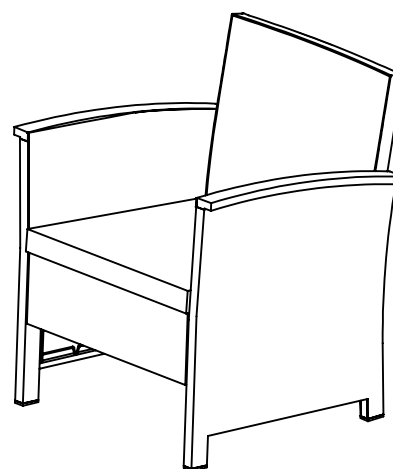

# PARTS LIST - SOFA (C)

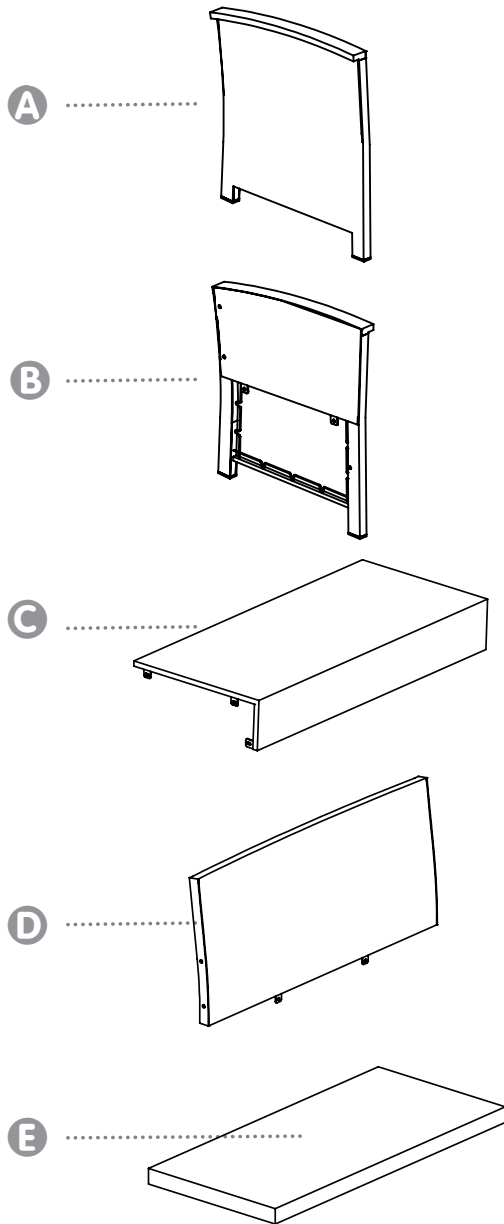

PART	DESCRIPTION	QUANTITY
A	Left* Side Panel	1
B	Right* Side Panel	1
C	Seat Panel	1
D	Back Panel	1
E	Seat Cushion	1

*\*When facing the front of the sofa*



## HARDWARE CONTENTS



**F**  
M6x25 Bolt  
Qty: 8



**G**  
M6x35 Bolt  
Qty: 4



**H**  
Washer  
Qty: 12



Hex Key

Assemble in a clear area on a spacious, nonabrasive surface such as a carpet or blanket. Wait to fully tighten hardware until final step. Do not over-tighten hardware.

# ASSEMBLY - SOFA (C)

**1** Locate the **Right Side Panel (B)** and **Seat Panel (C)**. Place a **Washer (H)** on each of 3 **Bolts (F)**. Align the panels as shown. Insert each **Bolt** with **Washer** through the eyelets in the **Seat Panel** and into the holes in the edge of the **Right Side Panel**.

Tighten using the **Hex Key**, but do not over-tighten.



Hardware Used:

**F Bolt (M6x25) x3**

**H Washer x3**

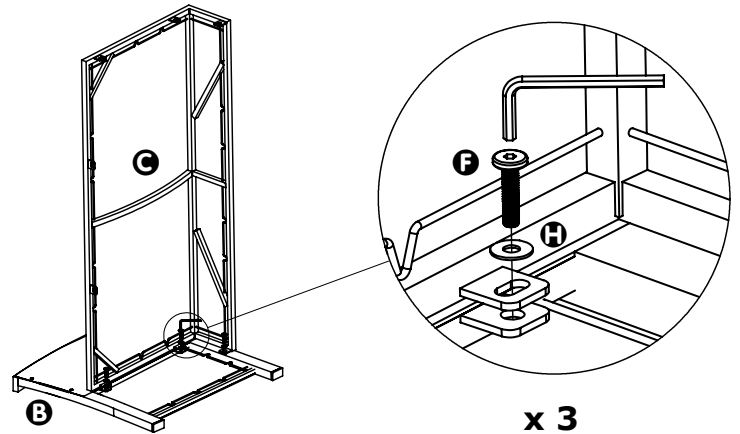

**2** Attach the **Back Panel (D)** to the **Right Side Panel (B)**: Place a **Washer (H)** on each of 2 **Bolts (G)**. Align the eyelets on the **Back Panel** with the holes in the **Right Side Panel** as shown, then insert a **Bolt** with **Washer** into each of the 2 aligned sets of eyelets.

Tighten using the **Hex Key**, but do not over-tighten.



Hardware Used:

**G Bolt (M6x35) x2**

**H Washer x2**

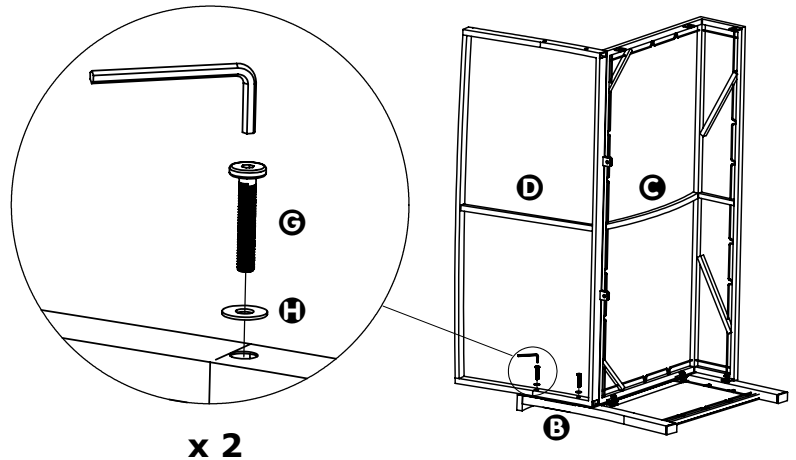

**3** Fasten the **Back Panel (D)** to the **Seat Panel (C)**: Place a **Washer (H)** on each of 2 **Bolts (F)**. Insert each **Bolt** with **Washer** into one of the 2 aligned sets of eyelets on the underside of the **Seat Panel**.

Tighten using the **Hex Key**, but do not over-tighten.



Hardware Used:

**F Bolt (M6x25) x2**

**H Washer x2**

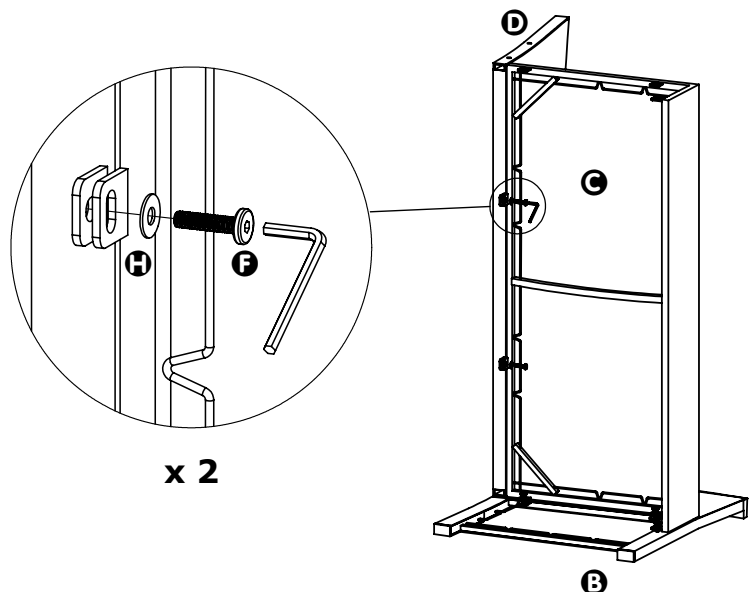

## ASSEMBLY - SOFA (C)

- 4** Locate the **Left Side Panel (D)**. Place a **Washer (H)** on each of 2 **Bolts (G)**. Place the partially-assembled sofa on the **Left Side Panel** as shown. Align the eyelets on the edge of the **Back Panel** with the holes in the **Left Side Panel** and insert a **Bolt** with **Washer** through each of the 2 aligned sets of eyelets.

Tighten Bolts using the **Hex Key**, but do not over-tighten.

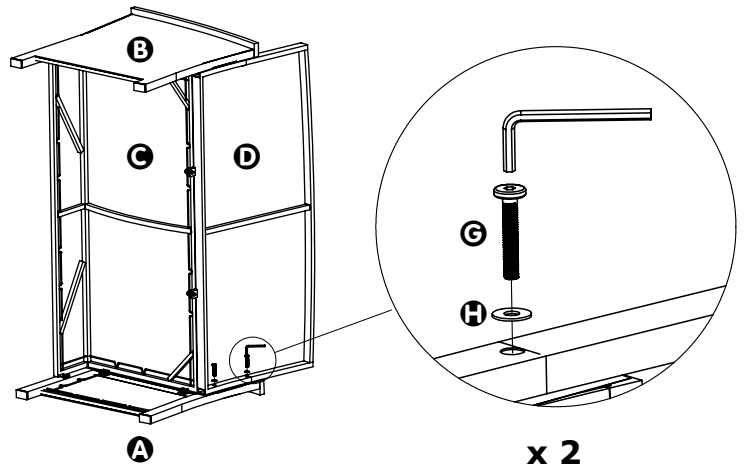

Hardware Used:

**G** Bolt (M6x35) x2

**H** Washer x2

- 5** Place a **Washer (H)** on each of 3 **Bolts (F)**. To attach the **Left Side Panel (C)** to the **Seat Panel (B)**, insert a **Bolt** with **Washer** into the 3 aligned sets of eyelets on the underside of the **Seat Panel**.

Tighten Bolts using the **Hex Key**, but do not over-tighten.

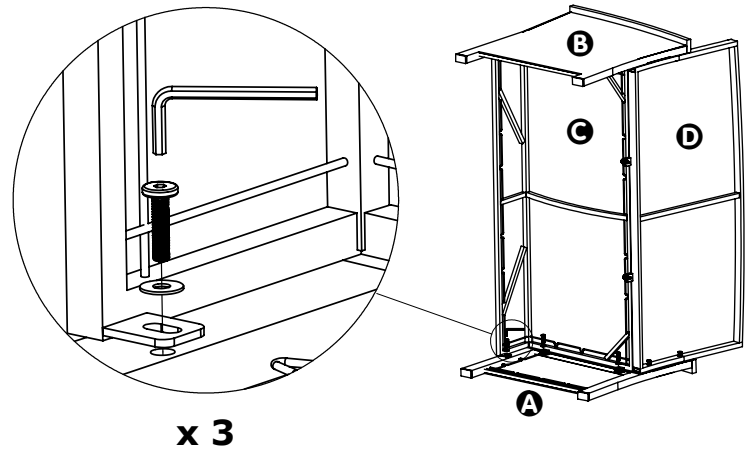

Hardware Used:

**F** Bolt (M6x25) x3

**H** Washer x3

- 6** Turn assembled sofa upright on a flat, level surface to ensure that it sits squarely and level on the ground. Adjust fastenings if needed, then firmly tighten all **Bolts**.

Place the **Seat Cushion (E)** in the seat.

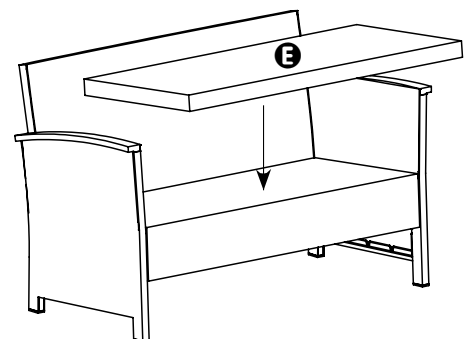

Your Sofa is fully assembled!

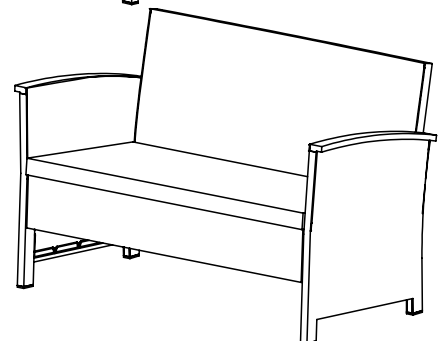

# PARTS LIST - TABLE (D)

PART	DESCRIPTION	QUANTITY
A	Glass Tabletop	1
B	Table Frame	1
C	Leg	4
D	Shelf	1

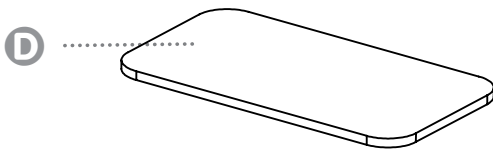
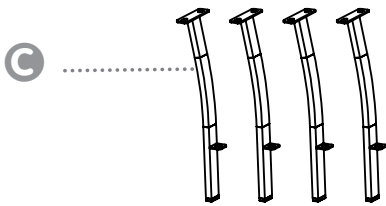
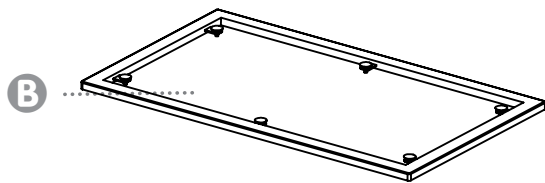
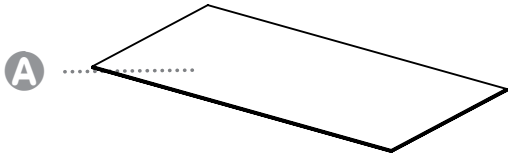

## HARDWARE CONTENTS



**E**  
M6x15 Bolt  
Qty: 12



**F**  
Washer  
Qty: 12



Hex Key

Assemble in a clear area on a spacious, nonabrasive surface such as a carpet or blanket. Wait to fully tighten hardware until final step. Do not over-tighten hardware.

## ASSEMBLY - TABLE (D)

**1** Place the **Table Frame (B)** upside-down on a protected surface (Bolt holes will be visible at each corner). Place a **Washer (F)** on each of 8 **Bolts (E)**.

Position a **Leg (C)** at the corner of the **Table Frame** as shown, aligning the eyelets in the top plate of the **Leg** with the threaded holes in the **Table Frame**. Insert a **Bolt** with **Washer** into each of the the aligned sets of eyelets.

Repeat to install remaining 3 **Legs**.

Tighten **Bolts** with the **Hex Key**, but do not over-tighten.

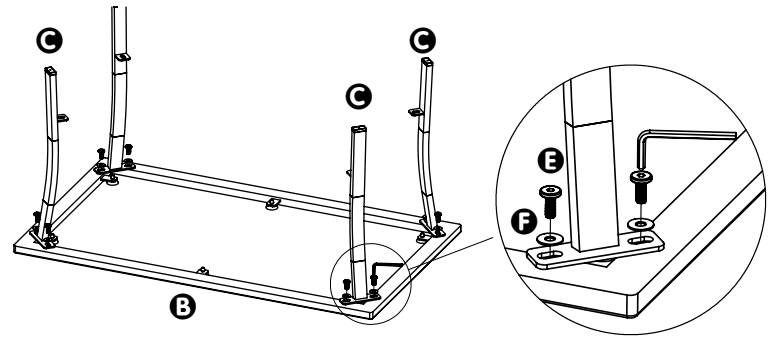

x 4



**Hardware Used:**  
**E Bolt (M6x15) x8**  
**F Washer x8**

**2** Place a **Washer (F)** on each of 4 **Bolts (E)**. Position the **Shelf (D)** between the installed **Legs** as shown, then insert a **Bolt** with **Washer** through each bracket eyelet and into the threaded holes in the bottom of the **Shelf**.

Tighten **Bolts** with the **Hex Key**, but do not over-tighten.

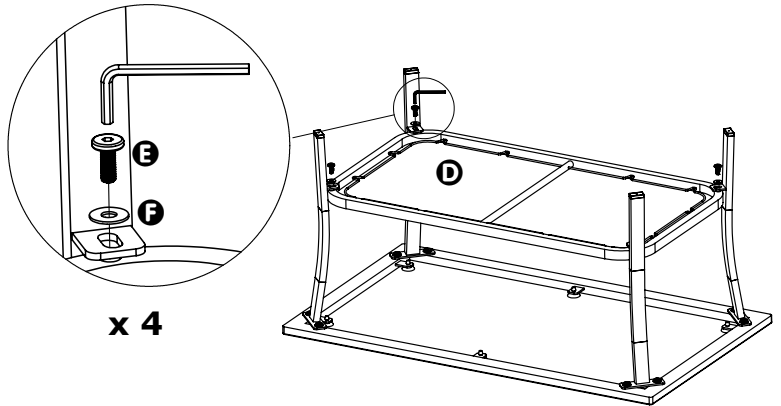

x 4



**Hardware Used:**  
**E Bolt (M6x15) x4**  
**F Washer x4**

**3** Turn assembled table upright on a flat, level surface to ensure that it sits squarely and level on the ground. Adjust fastenings if needed, then firmly tighten all **Bolts**.

Carefully place the **Glass Tabletop (A)** on the **Table Frame**.

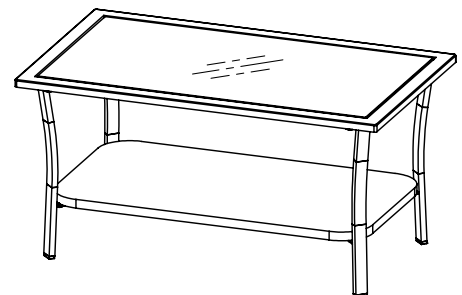
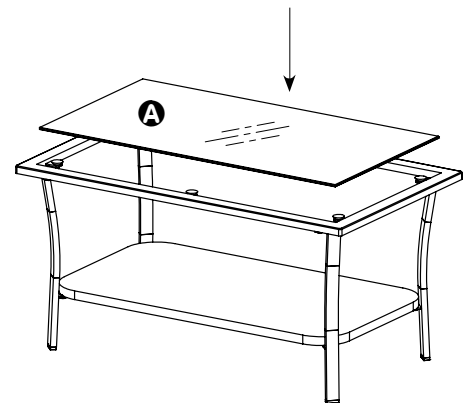

Your Table is fully assembled!



# 1 YEAR LIMITED WARRANTY

## Customers in the Contiguous US

All components are warranted for a period of 1 year after date of purchase by the original owner against defects in materials and workmanship under normal use. This warranty does not cover normal wear and weathering,, assembly and/or maintenance or use in a commercial application if model is not designated as a commercial model. At our sole discretion, products under warranty will be repaired and/or replaced at no charge to the customer. In returns sent back to us must be sent via prepaid freight and in the original retail packaging.

For warranty service contact us at the address, phone numbers or internet site and email listed in this owner's manual. Be sure to have your sales receipt, date of purchase and catalogue/model numbers available when calling. All warranty service will be coordinated by service center.

This warranty is extended only to the original purchaser. Proof of purchase will be required before warranty service is rendered. The sales receipt is the only valid proof of purchase. This warranty only covers failures due

to defects in materials or workmanship which occur during normal use. Failures and/or damage which result from accident, negligence, misuse, abuse, neglect, mishandling,,alteration, or modification, failure to maintain, improper assembly or maintenance, service by unauthorized agency, use of unauthorized components, or damage that is attributable to acts of God are NOT covered.

THIS LIMITED WARRANTY GIVES YOU SPECIFIC LEGAL RIGHTS AND YOU MAY ALSO HAVE OTHER RIGHTS WHICH VARY FROM JURISDICTION TO JURISDICTION. THE PROVISIONS OF THE UNITED NATIONS CONVENTION ON CONTRACTS FOR THE SALES OF GOODS SHALL NOT APPLY TO THIS LIMITED WARRANTY OR THE SALE OF PRODUCTS COVERED BY THIS LIMITED WARRANTY.

·THERE ARE NO EXPRESS WARRANTIES EXCEPT AS LISTED HERE

·PURCHASER ASSUMES ALL RISKS IN THE ASSEMBLY AND OPERATION OF THIS UNIT

·FAILURE TO FOLLOW WARNINGS AND OPERATIONAL INSTRUCTIONS CONTAINED IN THIS MANUAL CAN RESULT IN SEVERE PROPERTY DAMAGE AND/OR PERSONAL INJURY

·IN NO EVENT WILL DIRECTORS, OFFICERS OR AGENTS BE LIABLE TO THE PURCHASER OR ANY THIRD PARTY, WHETHER IN CONTRACT, IN TORT, OR ON ANY OTHER BASIS, FOR ANY INDIRECT, SPECIAL, PUNITIVE, EXEMPLARY, CONSEQUENTIAL, OR INCIDENTAL LOSS, COST, OR DAMAGE ARISING OUT OF OR IN CONNECTION WITH THE SALE, MAINTENANCE, USE, OR INABILITY TO USE THE PRODUCT, EVEN IF DIRECTORS, OFFICERS OR AGENTS HAVE BEEN ADVISED OF THE POSSIBILITY OF SUCH LOSSES, COSTS OR DAMAGES, OR IF SUCH LOSSES, COSTS, OR DAMAGES ARE FORESEEABLE. IN NO EVENT WILL OFFICERS, DIRECTORS, OR AGENTS BE LIABLE FOR ANY DIRECT LOSSES, COSTS OR DAMAGES THAT EXCEED THE PURCHASE PRICE OF THE PRODUCT.

·SOME JURISDICTIONS DO NOT ALLOW THE EXCLUSION OR LIMITATION OF INCIDENTAL OR CONSEQUENTIAL DAMAGES, SO THE ABOVE LIMITATION OR EXCLUSION MAY NOT APPLY TO THE PURCHASER.



## Important Notice

Do NOT return to place of purchase—for customer service and warranty issues contact our customer service center, email us, or goonline and live chat.