

PRODUCT GUIDE & ASSEMBLY INSTRUCTIONS

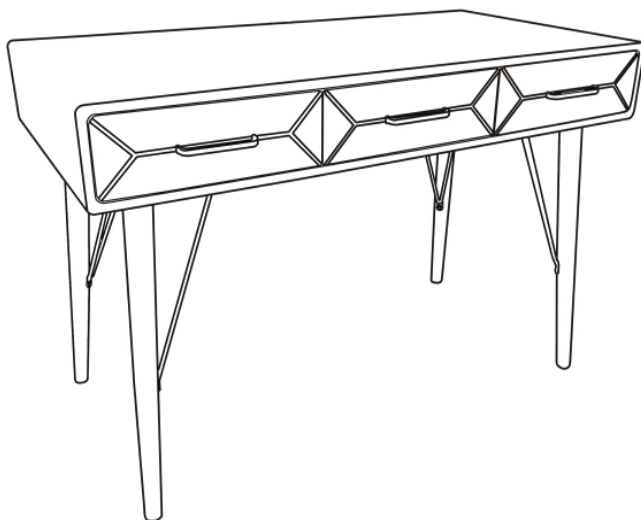

Console Table

Should you prefer to speak with a customer service representative, you may call toll free

Guidelines

**FAILURE TO FOLLOW THESE WARNINGS
WHEN IN USE COULD RESULT IN INJURY**

- Do not stand on the item or use as a step ladder
- Do not use this item unless all bolts and screws are firmly secured and fastened.
- Check all bolts and screws every 90 days. As necessary tighten if any are loose.
- Lift up then move. Pushing over or dragging this product can result in an injury or cause damage to the floor and piece.

WARNING:

DO NOT LET CHILDREN PLAY IN OR AROUND THE UNIT DUE TO THE POSSIBLE RISK OF INJURY.

Pre-Assembly Preparation:

Please read through this instruction booklet before beginning assembly of this item.

Two adults are recommended for assembly.

- Clear out the space for assembly and lay out all parts on Parts List, extra room will allow you to easily determine if all the pieces are present.
- Save all packing materials until assembly is complete to avoid accidentally discarding smaller parts or hardware.
- Keep small parts and pieces away from children and pets until fully assembled.
- Please check for any loose screws and tighten them before you use.

Parts List

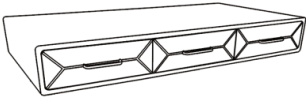

(A) Top (1)



(B) Legs (4)



(C) Leg Supports (4)



(D) Flat Washer (20)



(E) Long Bolts (8)



(F) Short Bolts (12)



(G) Allen Key 5mm (1)



(H) Leveler (4)



(I) Spring Washer (20)



(J) Allen Key 4mm (1)

Step 1

1. Ensure all parts have been removed from the carton and place on a protected surface or carpet.
2. Check all parts and hardware are the same as the "Parts List".
3. Attach Leg (B) to Top (A), fasten with Long Bolt (E), Spring Washer (I) and Flat washer(D) then tighten with Allen Key (G).

Noted: Ensure the assembly hole on Leg(B) were face inside for Leg Support (C) assembled.

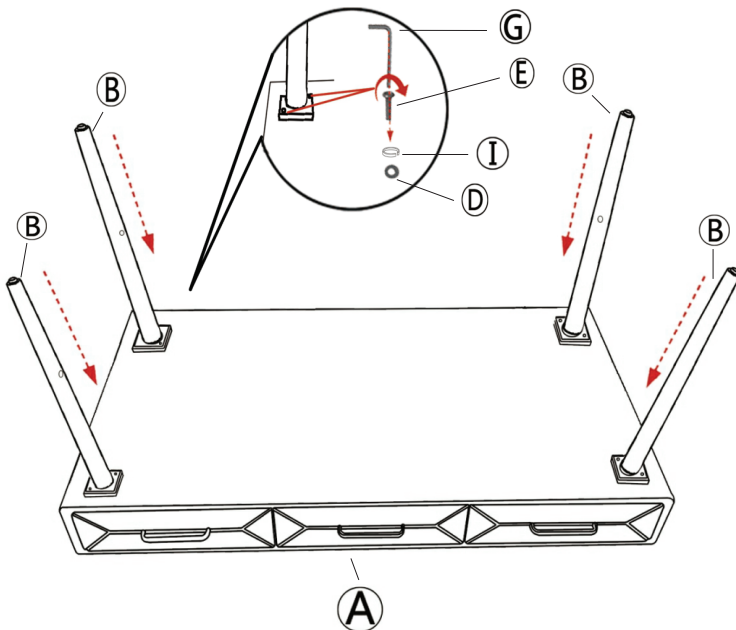

Step 2

1. Attach Leg Support (C) to Top (A) and Leg (B), fasten with Short Bolt (F), Spring Washer (I) and Flat washer(D) then tighten with Allen Key (J).

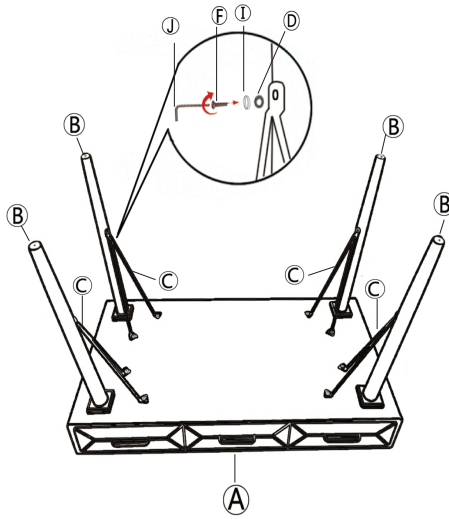
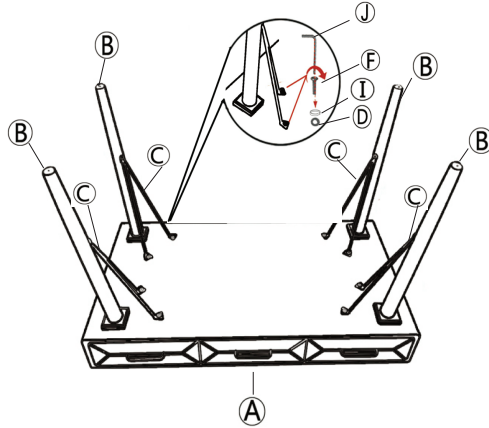

Step 3

1. Attached the Levelers (G) onto the Legs (B).

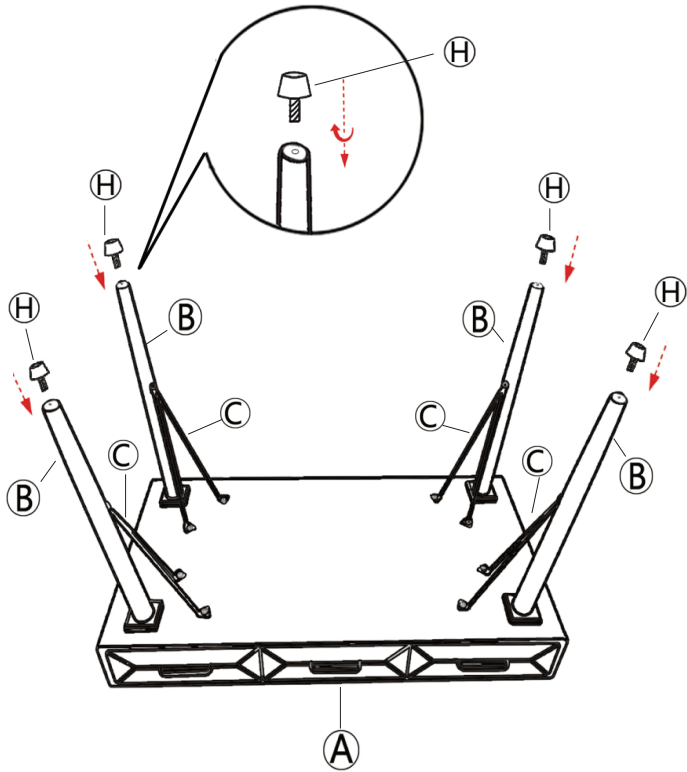

Step 4

1. Place the table onto a flat level surface and level the console by using the Foot Levelers (E). Tighten all bolts by using the Allen Key.

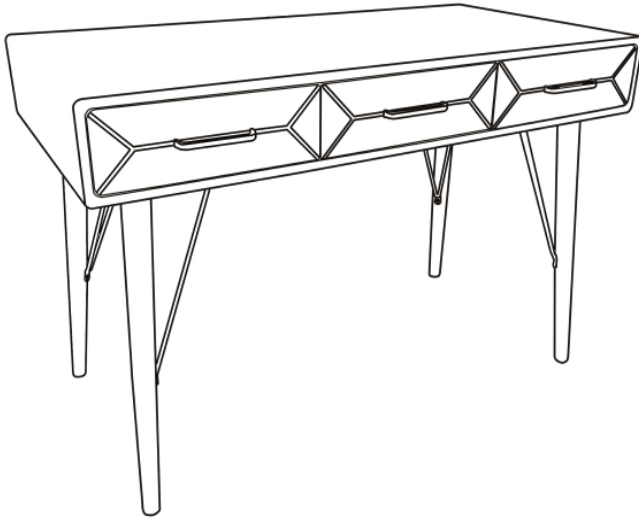

**Periodically (every 90 days) make sure that the screws are still fully tightened.
ATTENTION: Be certain that all screws are fully tightened before using table.**

Step 5

WE STRONGLY RECOMEND ATTACHING THIS UNIT TO THE WALL TO PREVENT THE TABLE FROM TOPPLING OVER.

Wall straps are already pre-assembled on table.

Assembly Steps to attach your table to the wall

1. Use a pencil to mark the fixing positions on the wall.
2. Drill holes and insert appropriate wall plugs into the wall (not provided).
3. Place the product against the wall and ensure that the strap is under top panel.
4. Secure the wall straps to the wall with appropriate screws for your wall type (not provided) and tighten with a screwdriver.

Warning:

1. Please note this item needs to be attached to the wall to prevent falling forward when product is in use.
2. Always ensure the intended wall area to be drilled is free from hidden electrical wires, water and gas pipes.

NB: Wall fixings are not included. Please source suitable fixings for your wall type. If in, consult a qualified trades professional.

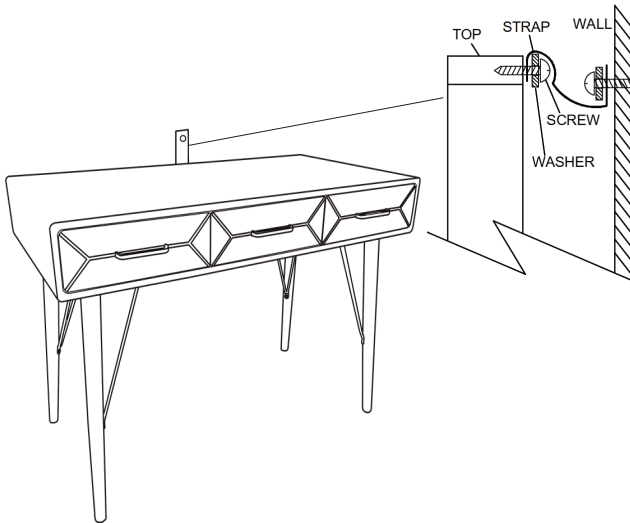

Product Dimension

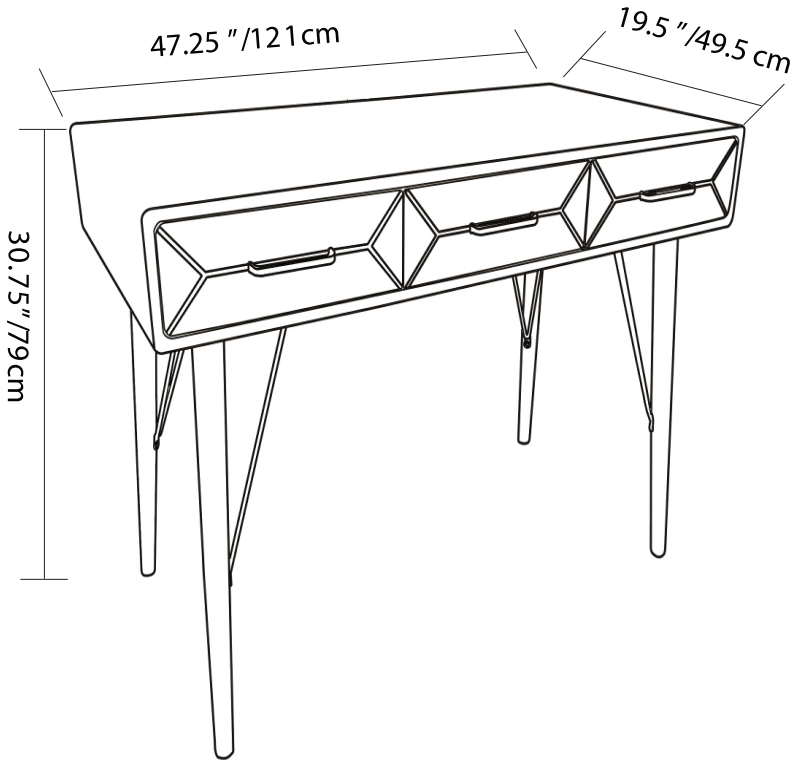

Limited Warranty

The manufacturer's products are warranted against defects in material and workmanship while owned by the "Original Purchaser". The term "Original Purchaser" is defined as the party or entity which purchases this manufacturer's furniture from an authorized retailer as shown by the original sales receipt. This warranty does not apply to "as is" or previously owned products.

The manufacturer warrants its products to be free from defects in materials and workmanship (normal wear and tear, fading and stretching excepted), for one year from the date of purchase, except as provided below under the limited warranty. The exceptions or exclusions to this warranty are as follows:

1. Any warranty claim that is submitted after the limited warranty period, or without proper proof of purchase will not include the cost of parts, labor, or delivery.
2. This warranty shall not apply to the manufacturer's products which have been subjected to misuse, neglect, alteration, modification, or attachments, either caused by the Original Purchaser, shipping, storage, accident, fire, flood, or acts of God.

In the event of a defect in material or workmanship covered by this warranty, the manufacturer will repair or replace, at their discretion, without charge the warranted parts within a reasonable amount of time. We reserve the right to require damaged parts be returned to us upon request. Natural markings such as scars, brands, grain variations, wrinkles, color variations, etc. will be considered normal characteristics and not construed as defects.

For claims or questions concerning this warranty, please contact customer service department on the web. Be prepared to provide your name, address, daytime phone number, the model and purchase order number of the product, date of purchase, and the website where it was purchased. The manufacturer requires that the original sales receipt be submitted with all requests to confirm that you are the Original Purchaser according to our written warranty.

This warranty gives you specific rights, and you may also have other rights, which vary from state to state (or country to country). All warranties are limited to the Original Purchaser for normal use. Should you prefer to speak with a service representative, you may call toll free.