

# Assembly Instructions

**CAUTION : You must read these Assembly Instructions before you proceed.**



## **SAFETY WARNING**

Never adjust chaise lounge or recliner backrest while seated.

Always make sure the backrest is flat before moving the chaise lounge.



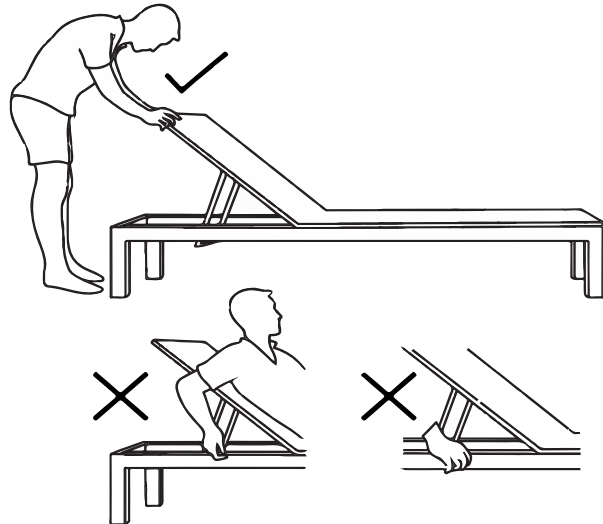

Keep all limbs clear from under the backrest when it is in a raised position.

Serious finger, hand, or other bodily injuries may result from adjusting the chaise lounge backrest position while seated.



The examples pictured above are non exhaustive and are for your reference only

## Care & Maintenance

- ⊘  ● Not for commercial use. For residential use only.
- ⊘  ● Prolonged exposure to rain may cause rusting which can stain floors.
- ⊘  ● Do not put hot items directly on furniture surface.
- ⊘  ● Do not clean furniture with harsh cleansers or polish.
- ✓  ● To obtain the longest lifespan of your outdoor products, minimizing exposure to direct sunlight is recommended.
- ⊘  ● Children should not climb or jump on the furniture.
- ⊘  ● Do not write on furniture without a padded barrier to protect the surface.
- ✓  ● To obtain the longest lifespan of your outdoor products, avoid extended and lengthy exposure to rain, snow, and direct sunshine. Whenever possible cover the product and /or place under patio or awnings.
- ⊘  ● Stains may be removed with mild soap solution and damp cloth.
- ✓  ● Keep away from sources of ignition.
- ✓  ● Dust and pick-up spills using a clean, non-colored, lint-free cloth.

Please look underneath the Chaise Lounge for hardware packs



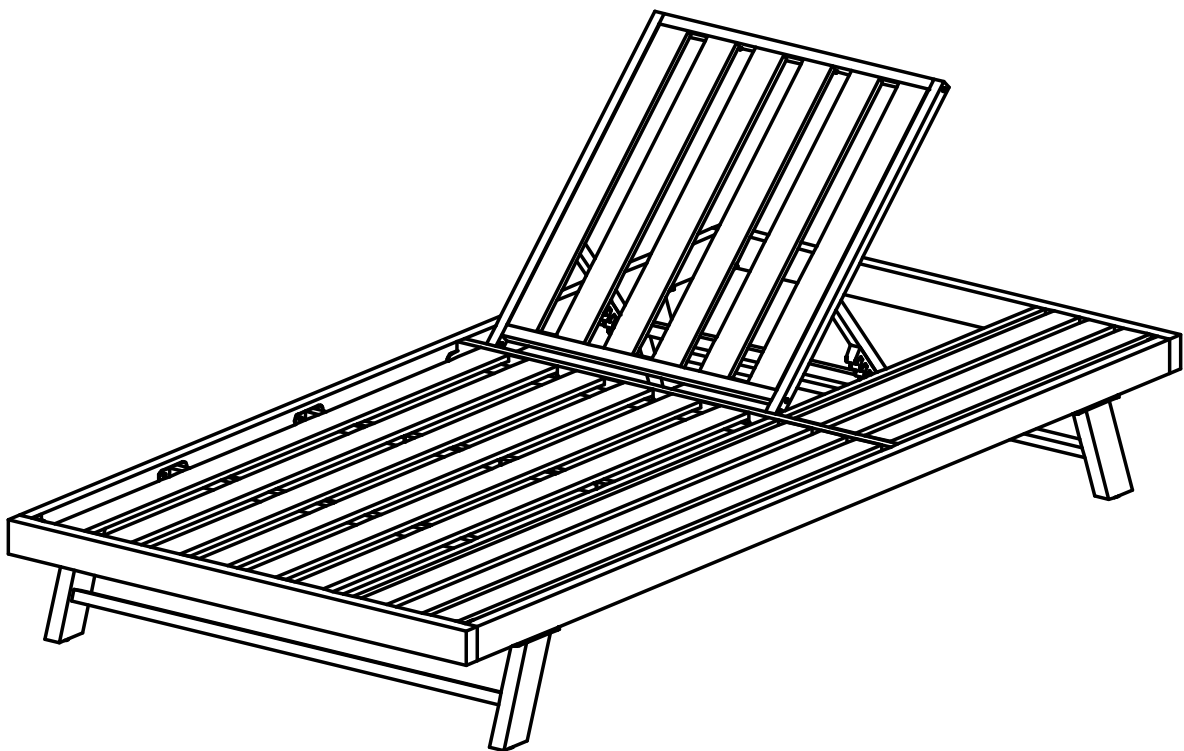

# CHAISE LOUNGE

N770P469100



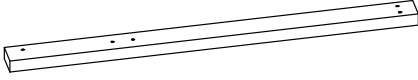
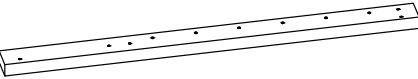
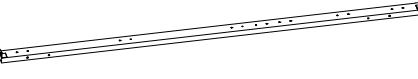
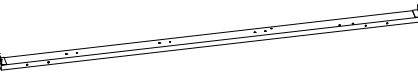
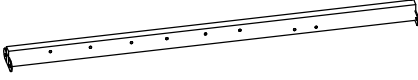

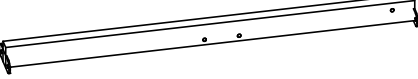

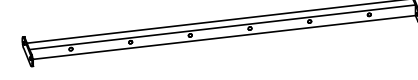

**CAUTION:** This Chaise Lounge is NOT a TOY.  
Keep your child / children at bay during the assembly process.  
For turning the Chaise Lounge and to prevent damage to the Chaise Lounge, 02 adults may be needed to execute this action.

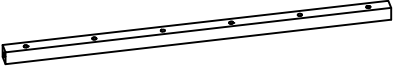
# Parts List

Label	Picture	Description	Q.TY
A		Seat Upper Frame	1
B		Seat Lower Frame	1
C		Seat Right Frame	1
D		Seat Left Frame	1
E		Seat Center Frame	1
F		Seat Lower Center	1
G		Seat Upper Center	1
H		Seat Slat	3
I		Seat Support Bar	2

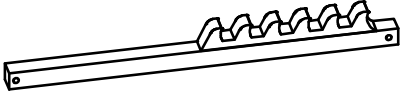
# Parts List

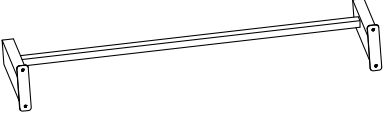
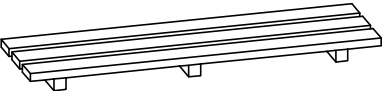
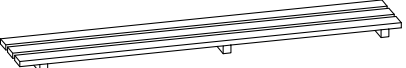
Label	Picture	Description	Q.TY
J		Backrest Slat	3
K		Backrest Crossbar	2
L		Right Backrest	1
M		Left Backrest	1
N		Backrest Support Crossbar	1
O		Backrest Support Bracket	2
P		Backrest Support Bar	1
Q		Support Bar	6
R		Leg	2
S		Wooden Seat Slat	1
T		Wooden Backrest Slat	1

# Hardware

Label	Picture	Description	Q.TY
①		Bolt (M6x15mm)	99
②		Bolt (M6x35mm)	9
③		Bolt (M6x45mm)	3
④		Washer (6x16x1mm)	113
⑤		Washer plastic (6x16x2mm)	3
⑥		Washer plastic (6x16x10mm)	3
⑦		Eru (M6)	3
⑧		Allen Wrench	2
⑨		Spanner	1

## Assembly Preparation

Before Beginning Assembly

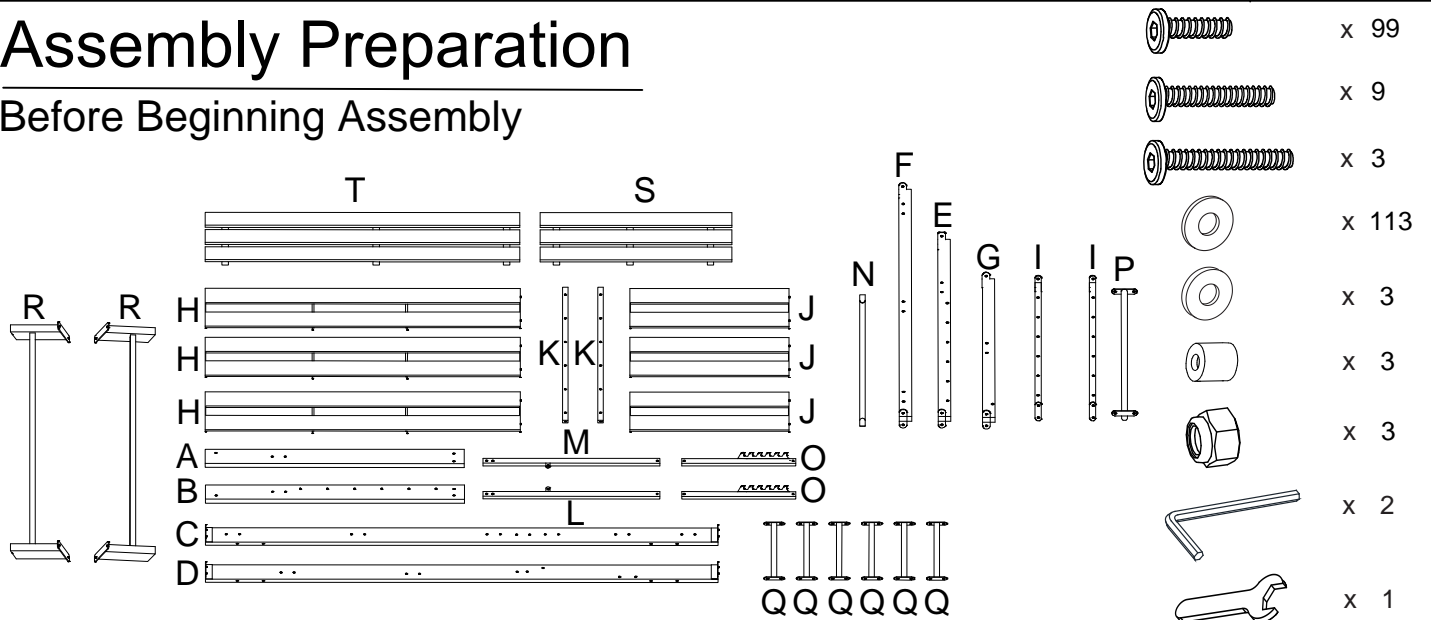

- Read instructions, cover to cover-
- Have 2 adults on hand for assembly-
- Do not assemble on flooring or carpet-
- Assemble on a clean non-marring surface (packing foam)-
- Save all packaging until finished-



## Step 2

### Step 2.1

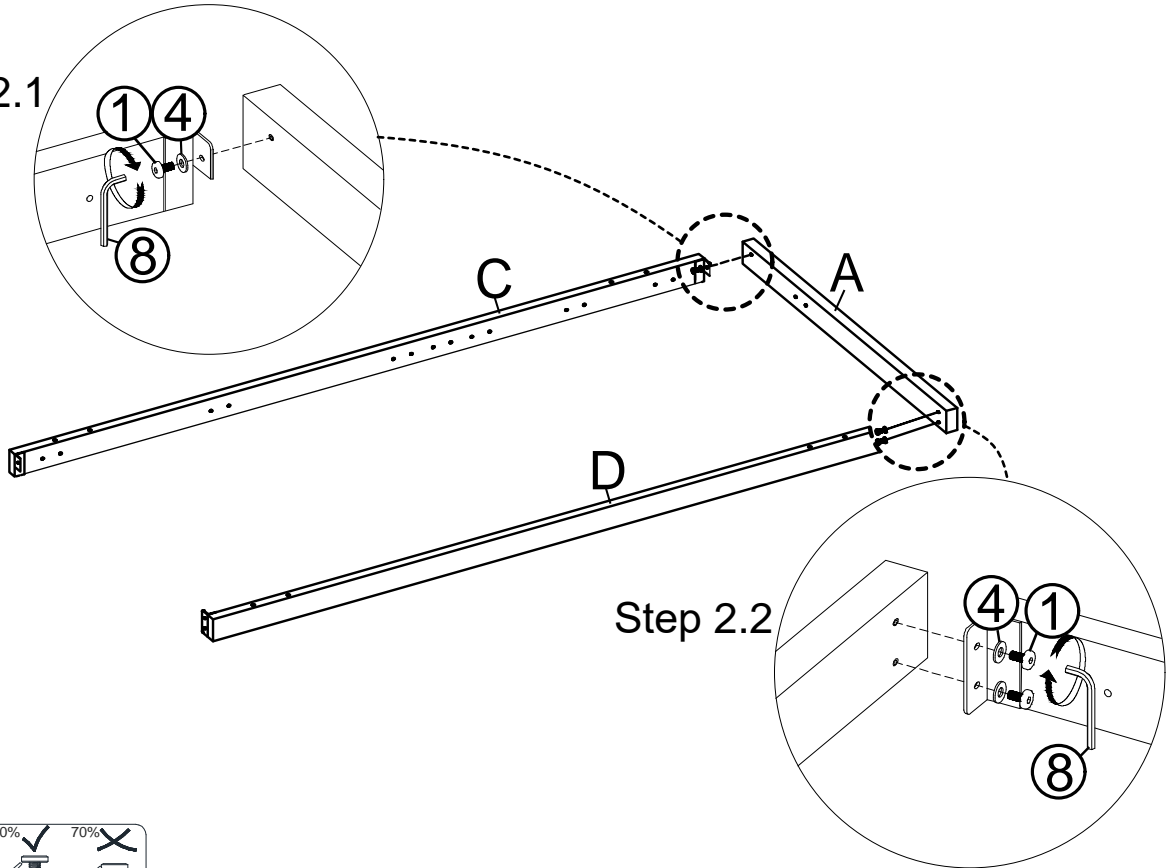

With the help from your partner. Attach the Seat Upper Frame (A):

2.1: To the Seat Right Frame (C) by using Bolt (1), Washer (4) and Allen Wrench (8) as shown above.

2.2: To the Seat Left Frame (D) by using Bolt (1), Washer (4) and Allen Wrench (8) as shown above.

**DO NOT fully tighten the Bolts at this time.**

## Step 3

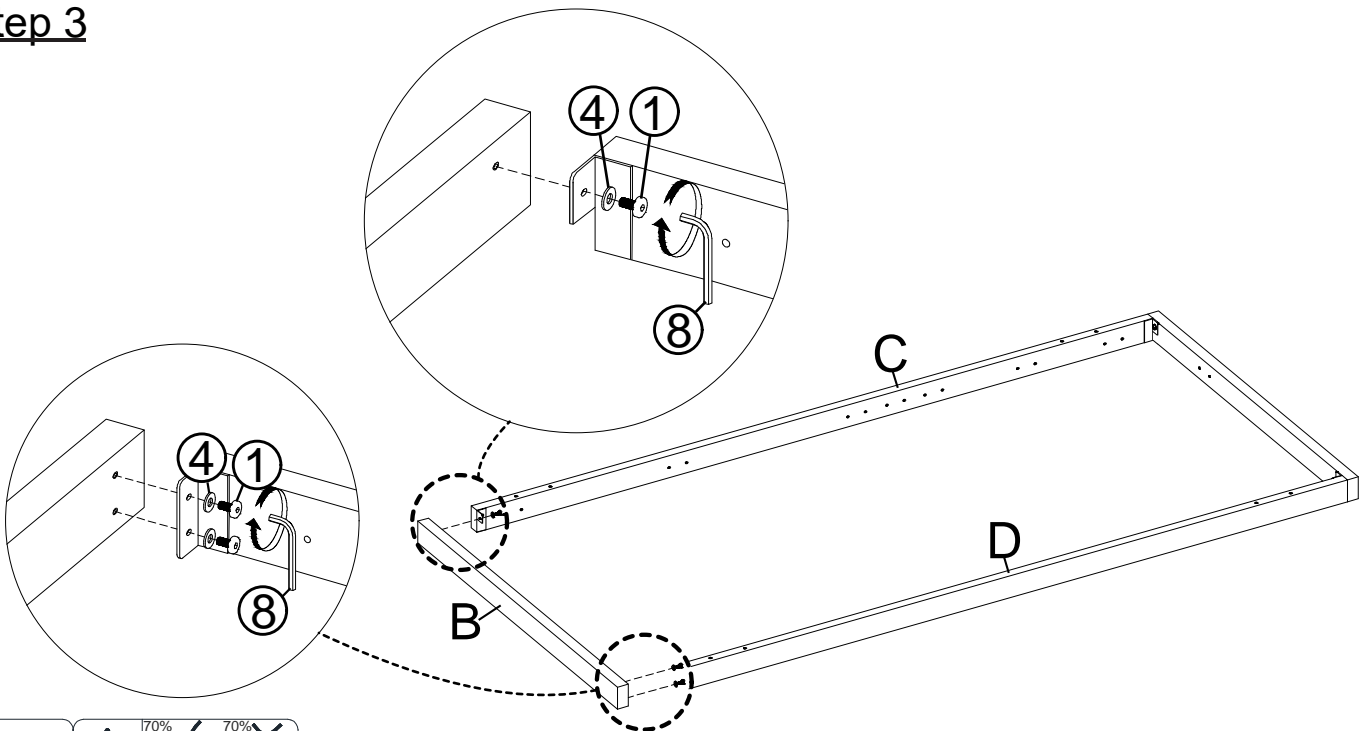

From Step 2. Attach the Seat Lower Frame (B) to the assembled part in Step 2 by using Bolt (1), Washer (4) and Allen Wrench (8) as shown above.

**DO NOT fully tighten the Bolts at this time.**

## Step 4

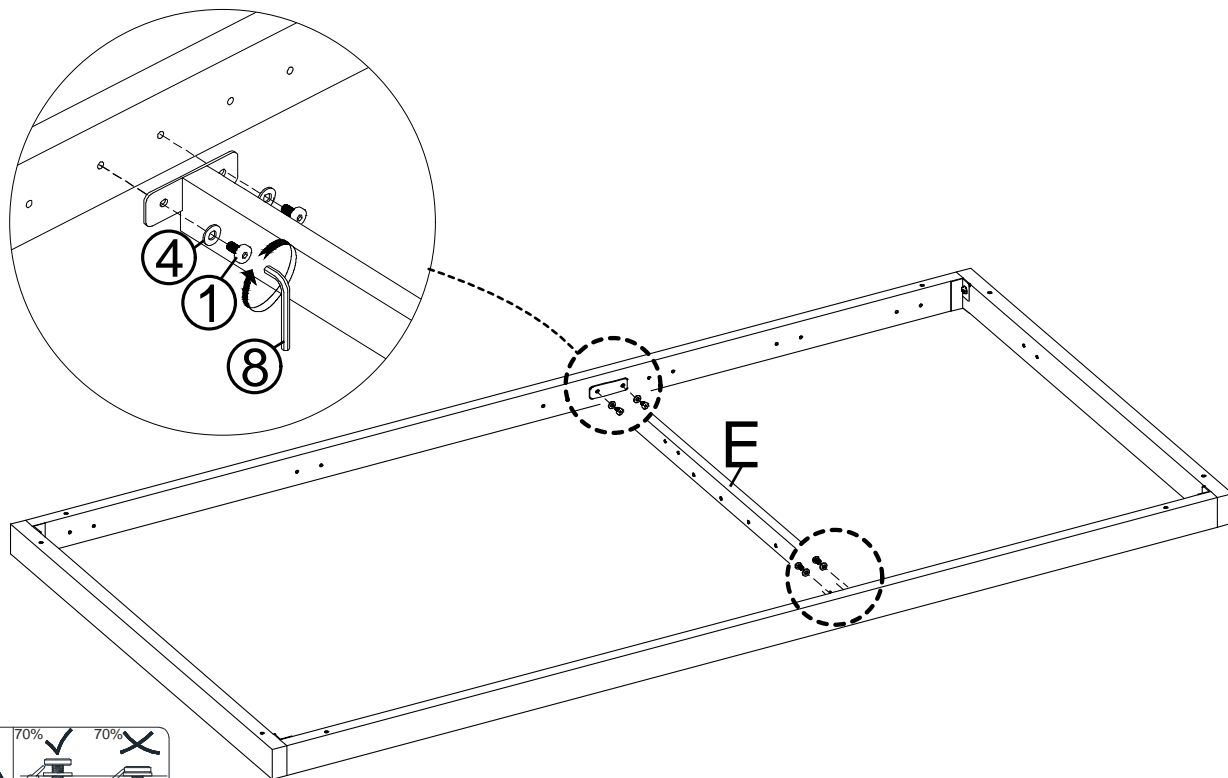

From Step 3. Attach the Seat Center Frame (E) to the assembled part in Step 3 by using Bolt (1), Washer (4) and Allen Wrench (8) as shown above.  
**DO NOT fully tighten the Bolts at this time.**

## Step 5

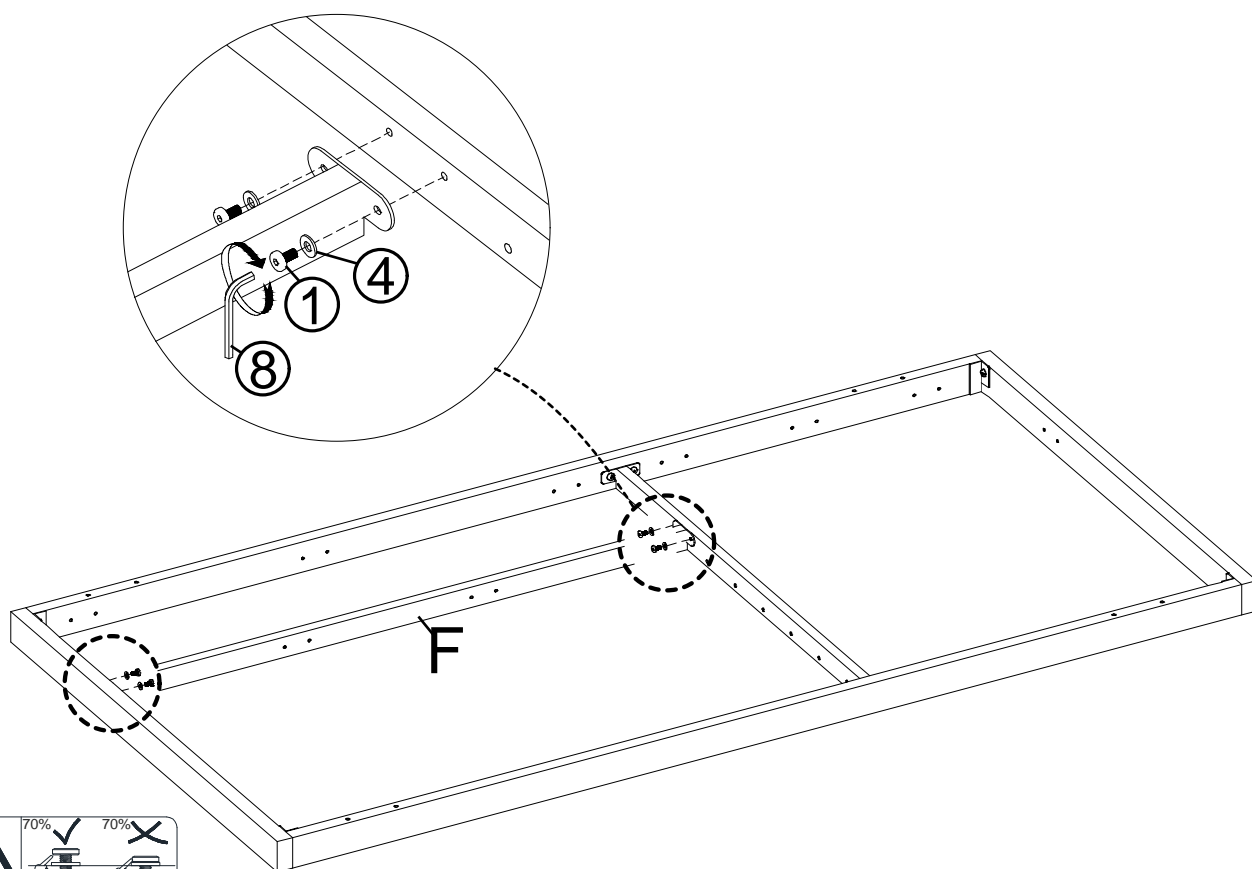

From Step 4. Attach the Seat Lower Center (F) to the assembled part in Step 4 by using Bolt (1), Washer (4) and Allen Wrench (8) as shown above.  
**DO NOT fully tighten the Bolts at this time.**

## Step 6

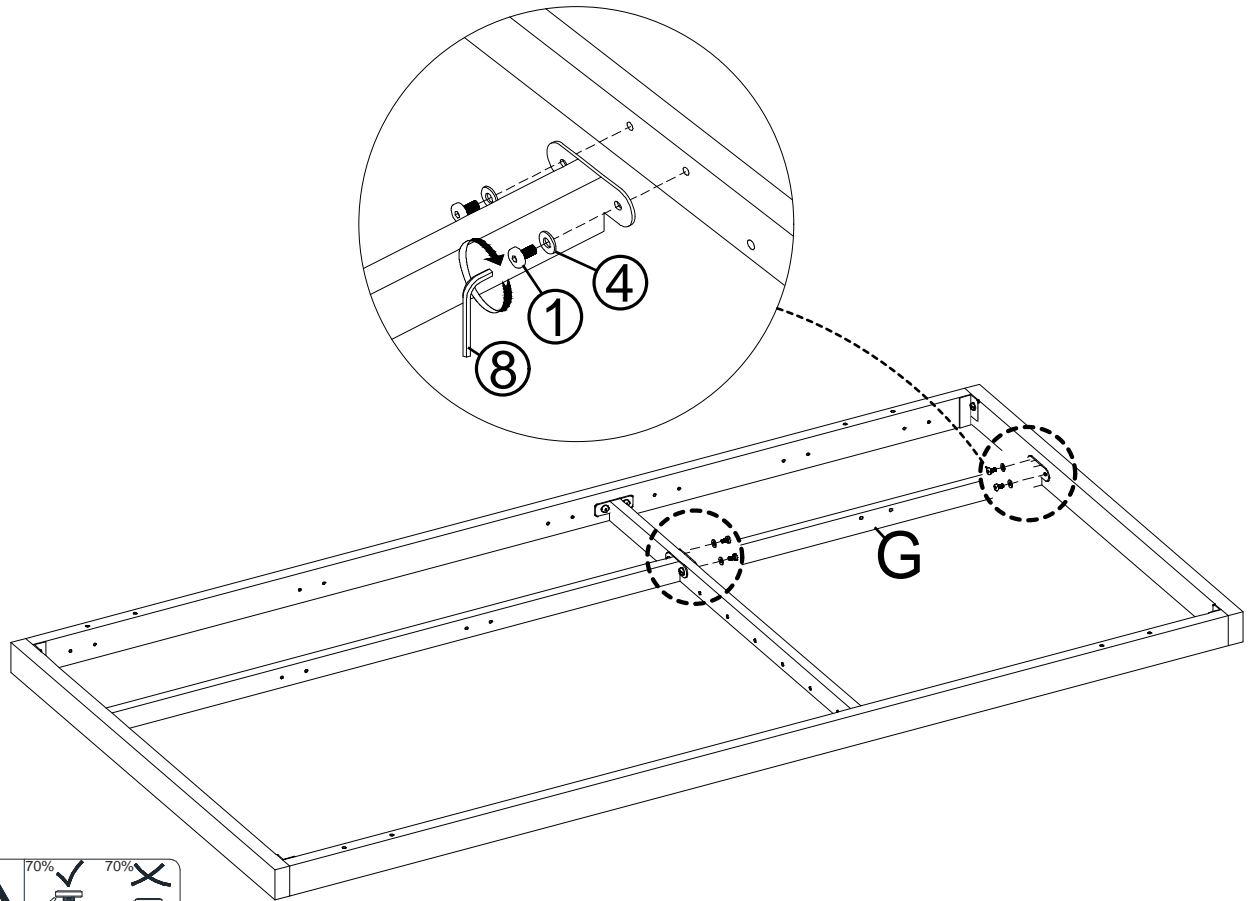

From Step 5. Attach the Seat Upper Center (G) to the assembled part in Step 5 by using Bolt (1), Washer (4) and Allen Wrench (8) as shown above.  
**DO NOT fully tighten the Bolts at this time.**

## Step 7

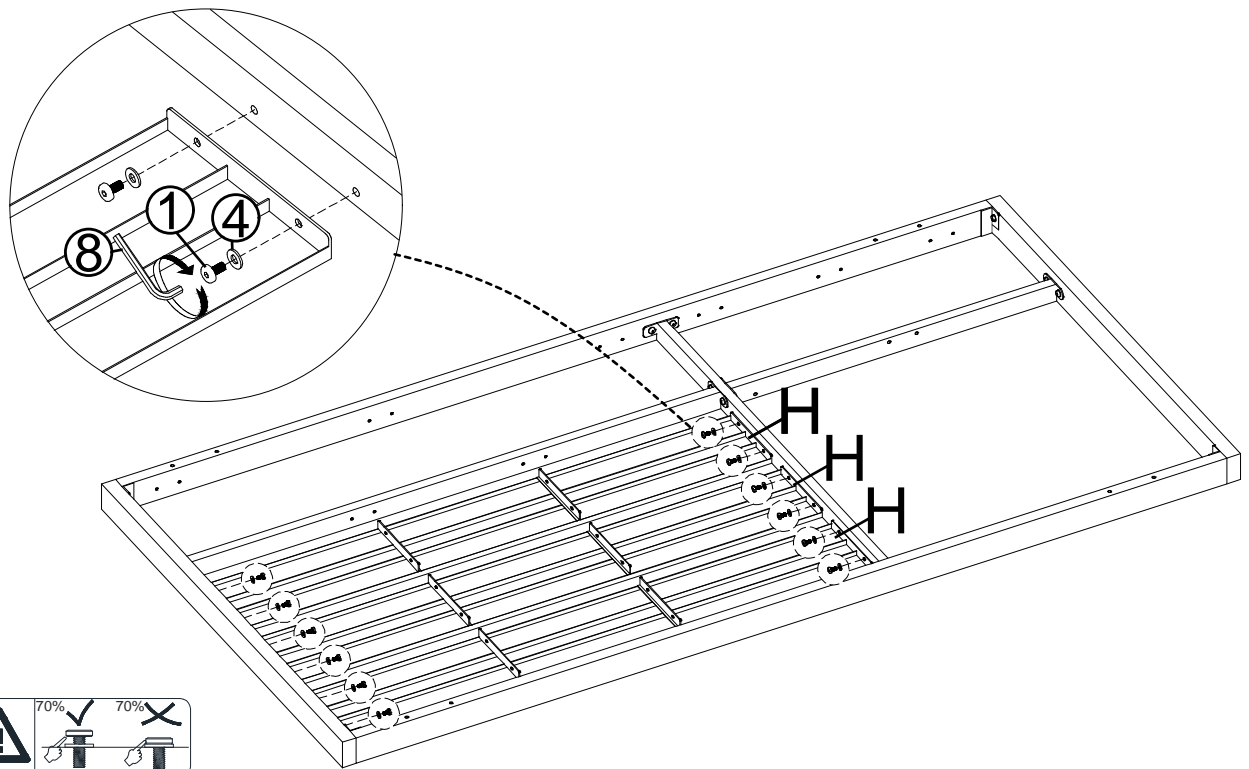

From Step 6. Attach the Seat Slat (H) to the assembled part in Step 6 by using Bolt (1), Washer (4) and Allen Wrench (8) as shown above.  
**DO NOT fully tighten the Bolts at this time.**

## Step 8

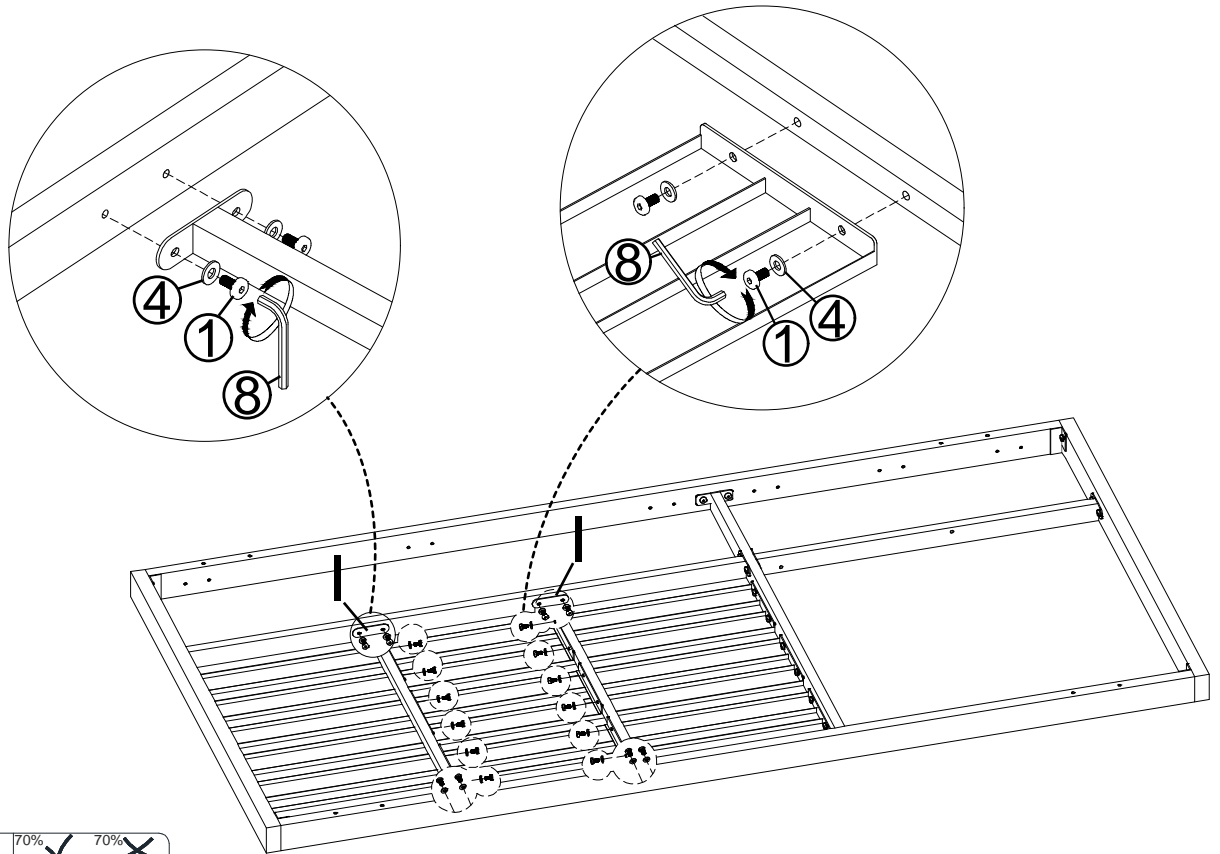

From Step 7. Attach the Seat Support Bar (I) to the assembled part in Step 7 by using Bolt (1), Washer (4) and Allen Wrench (8) as shown above.  
**DO NOT fully tighten the Bolts at this time.**

## Step 9

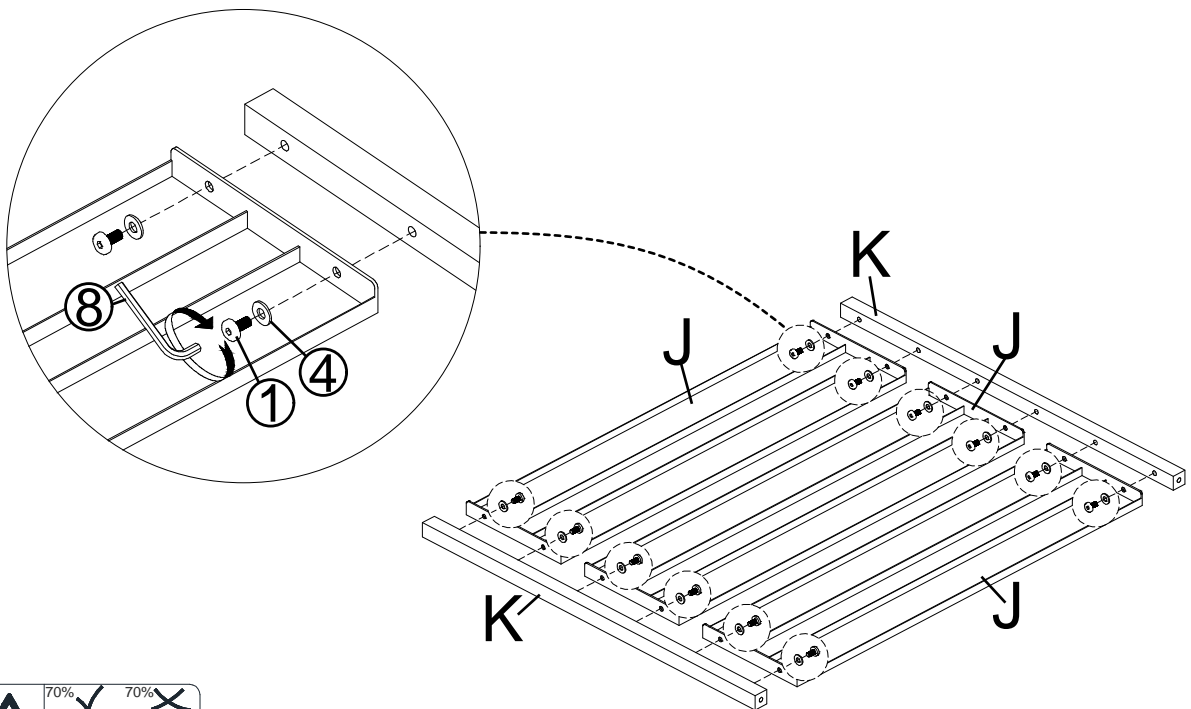

With the help from your partner carefully flip the frame over. Attach the Backrest Crossbar (K) to the Backrest Slat (J) By using Bolt (1), Washer (4) and Allen Wrench (8) as shown above.  
**DO NOT fully tighten the Bolts at this time.**

## Step 10

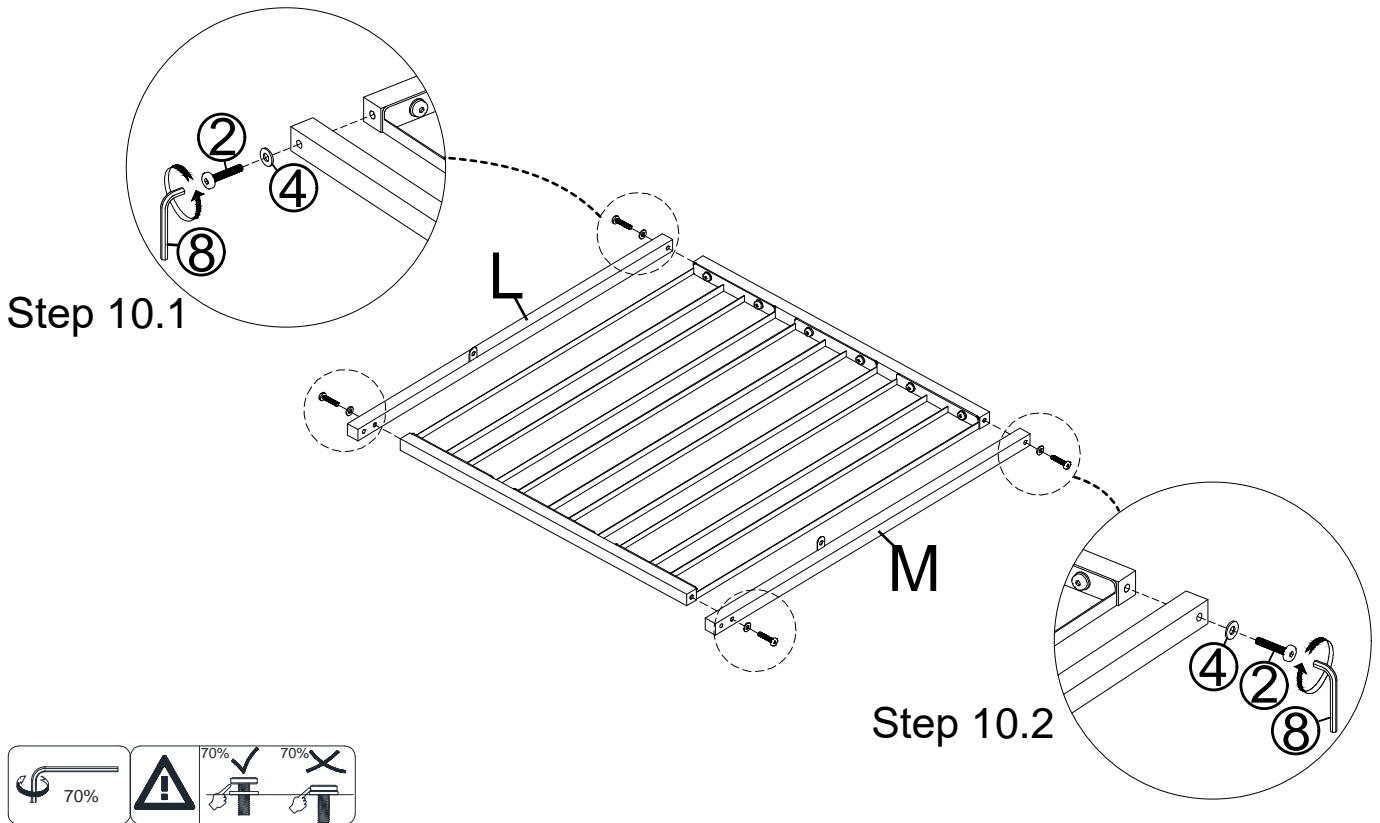

From Step 9 carefully flip the frame over:

10.1: Attach the Right Backrest (L) to the assembled part in Step 9 by using Bolt (2), Washer (4) and Allen Wrench (8) as shown above.

10.2: Attach the Left Backrest (M) to the assembled part in Step 9 by using Bolt (2), Washer (4) and Allen Wrench (8) as shown above.

## Step 11

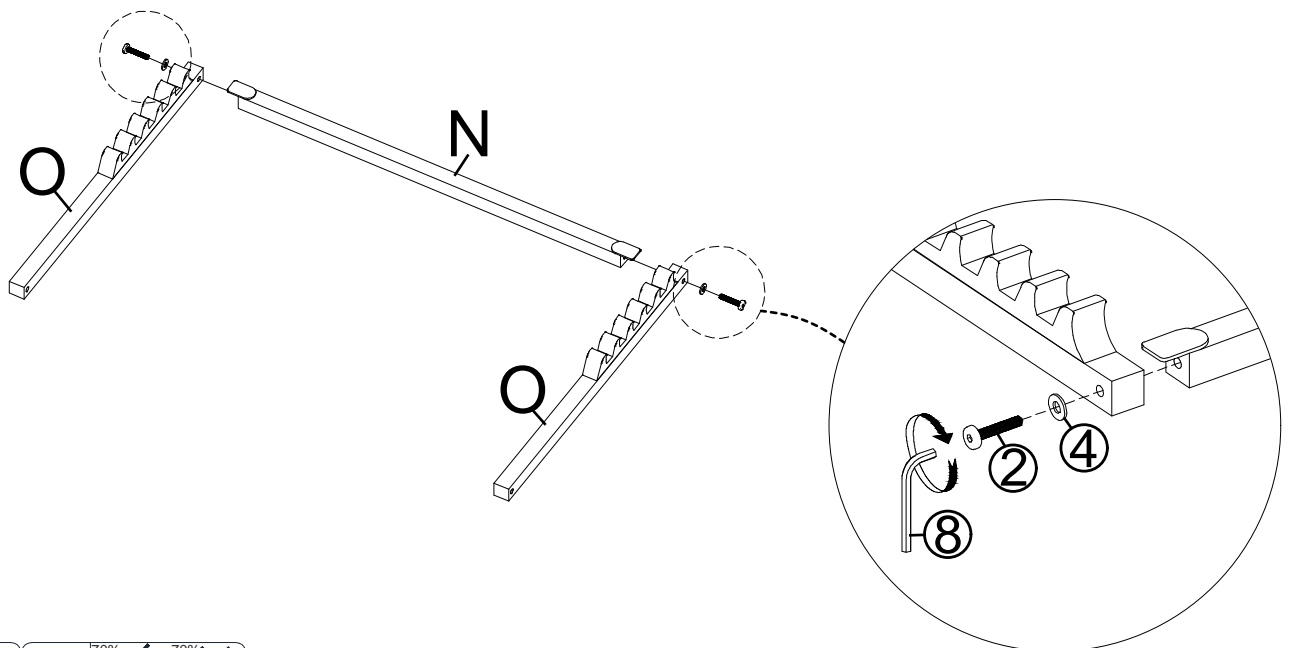

With the help from your partner. Attach the Backrest Support Crossbar (N) to the Backrest Support Bracket (O) By using Bolt (2), Washer (4) and Allen Wrench (8) as shown above.

**DO NOT fully tighten the Bolts at this time.**

## Step 12

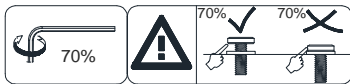
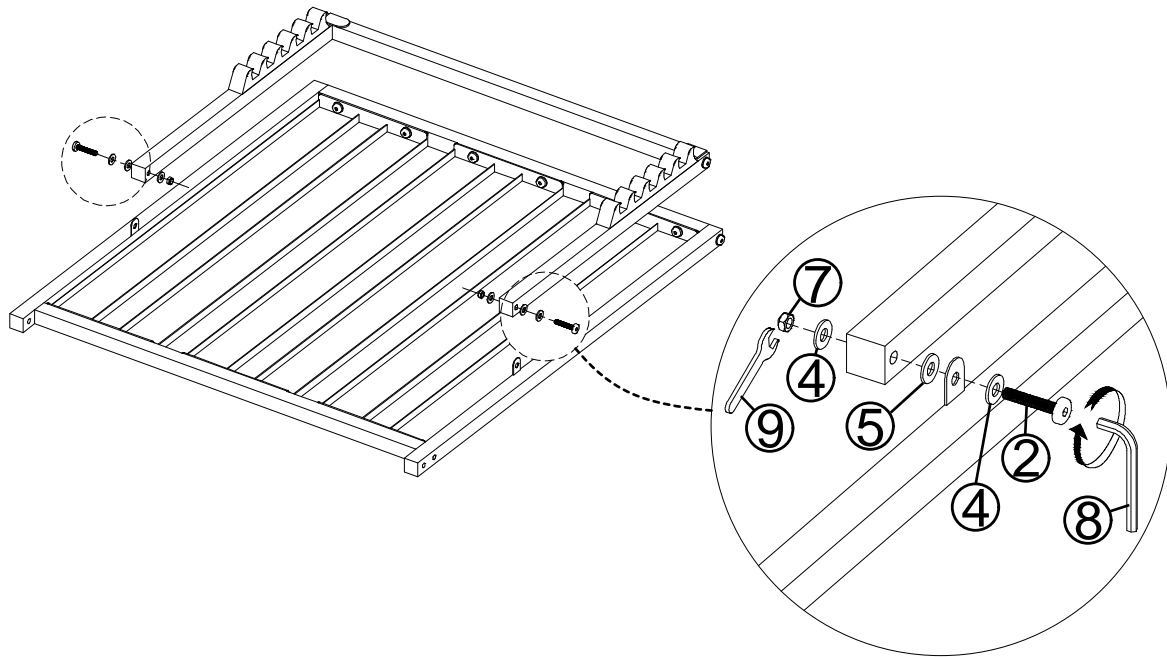

Attach the From Step 11 to the assembled part in Step 10 by using Bolt (2), Washer (4), Washer plastic (5), Eru (7), Spanner (9) and Allen Wrench (8) as shown above.  
**DO NOT fully tighten the Bolts at this time.**

## Step 13

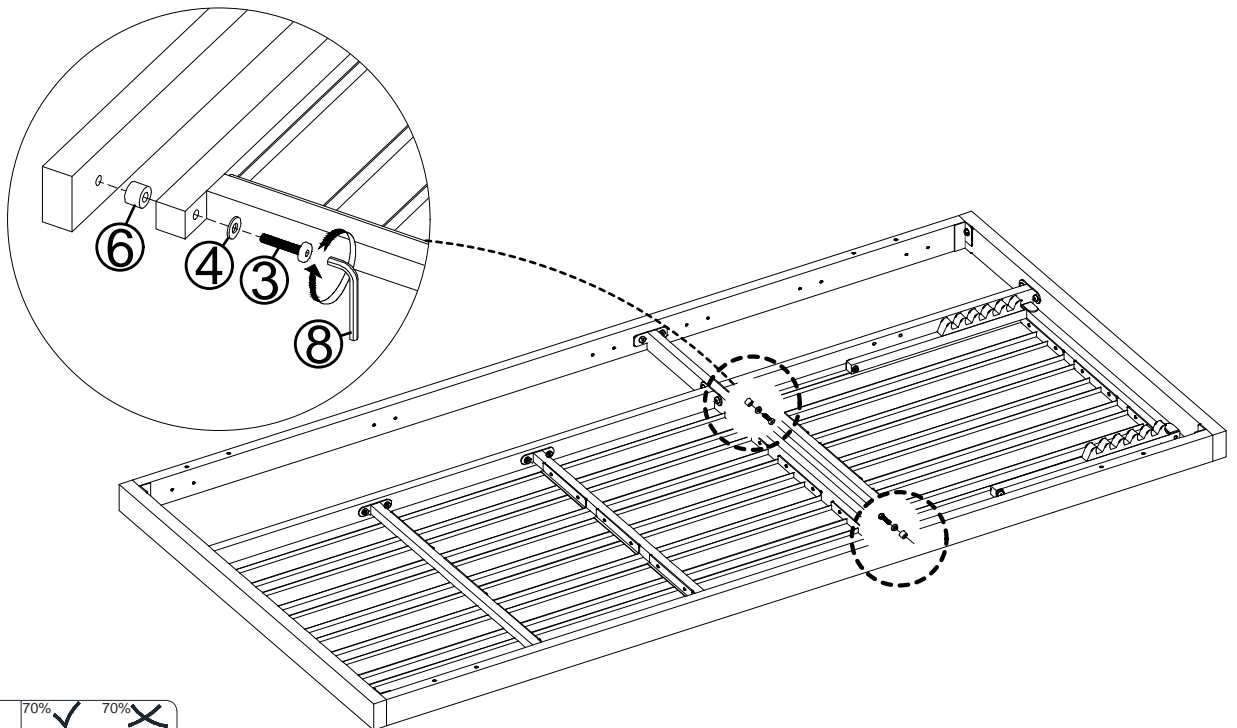

Attach the From Step 12 to the assembled part in Step 8 by using Bolt (3), Washer (4), Washer plastic (6) and Allen Wrench (8) as shown above.  
**DO NOT fully tighten the Bolts at this time.**

## Step 14

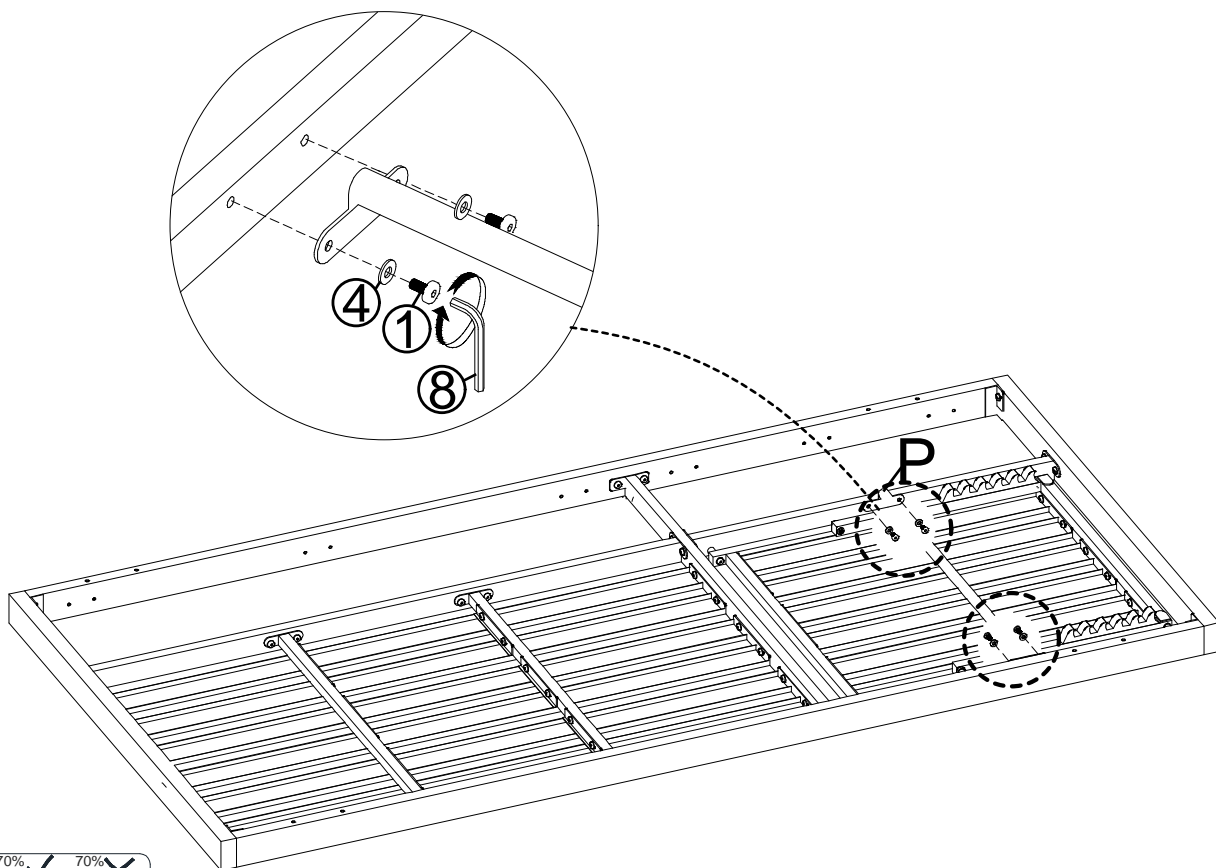

From Step 13. Attach the Backrest Support Bar (P) to the assembled part in Step 13 by using Bolt (1), Washer (4) and Allen Wrench (8) as shown above.  
**DO NOT fully tighten the Bolts at this time.**

## Step 15

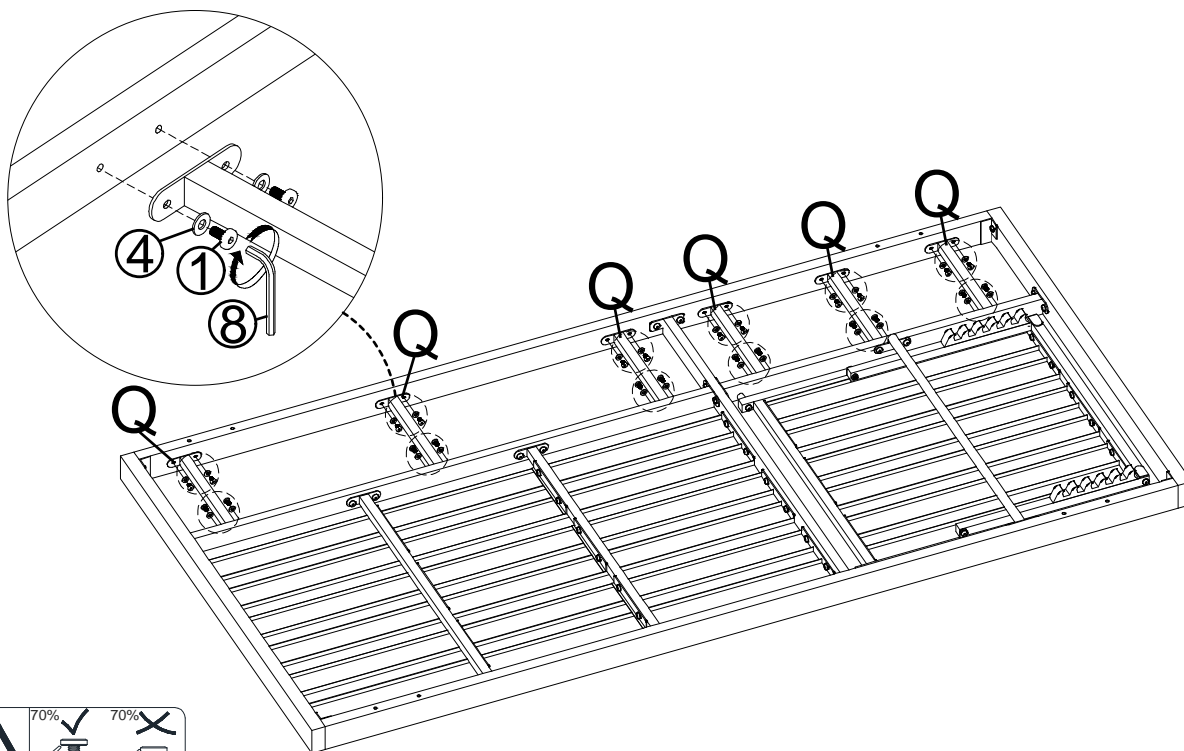

From Step 14. Attach the Support Bar (Q) to the assembled part in Step 14 by using Bolt (1), Washer (4) and Allen Wrench (8) as shown above.  
**DO NOT fully tighten the Bolts at this time.**

## Step 16

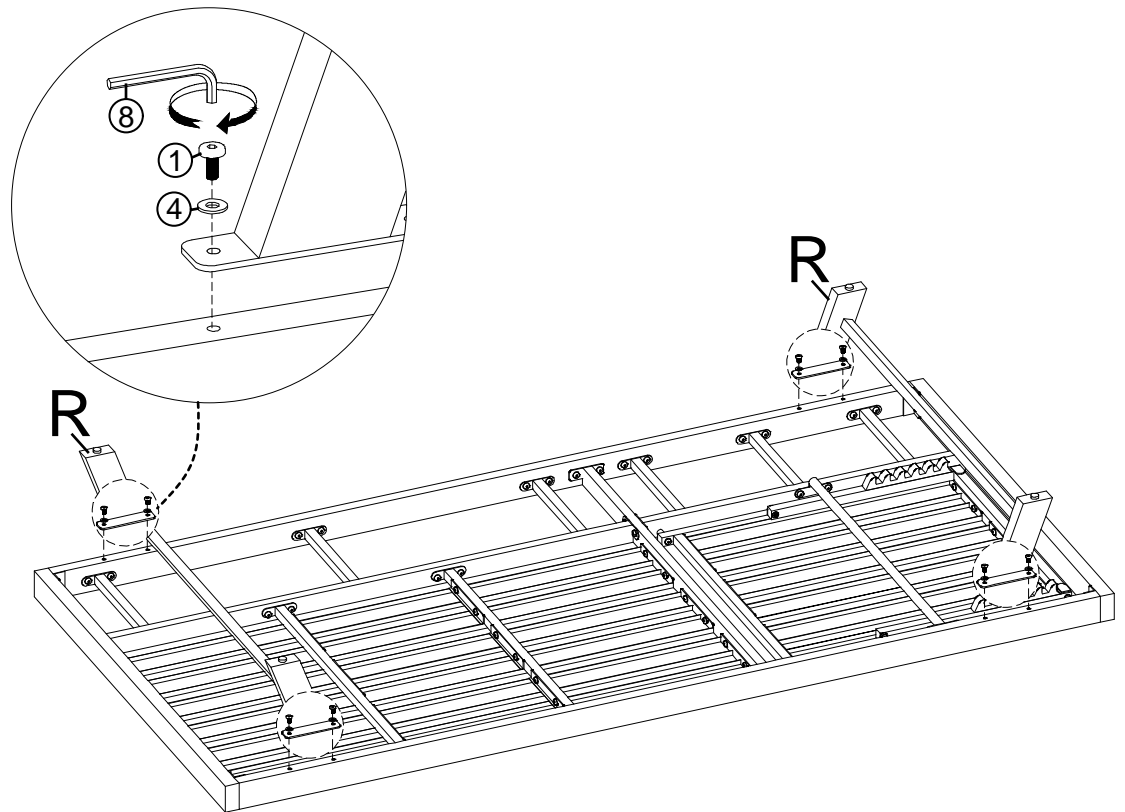

From Step 15. Attach the Leg (R) to the assembled part in Step 15 by using Bolt (1), Washers (4) and Allen Wrench (8) as shown above.  
**DO NOT** fully tighten the Bolts at this time.

## Step 17

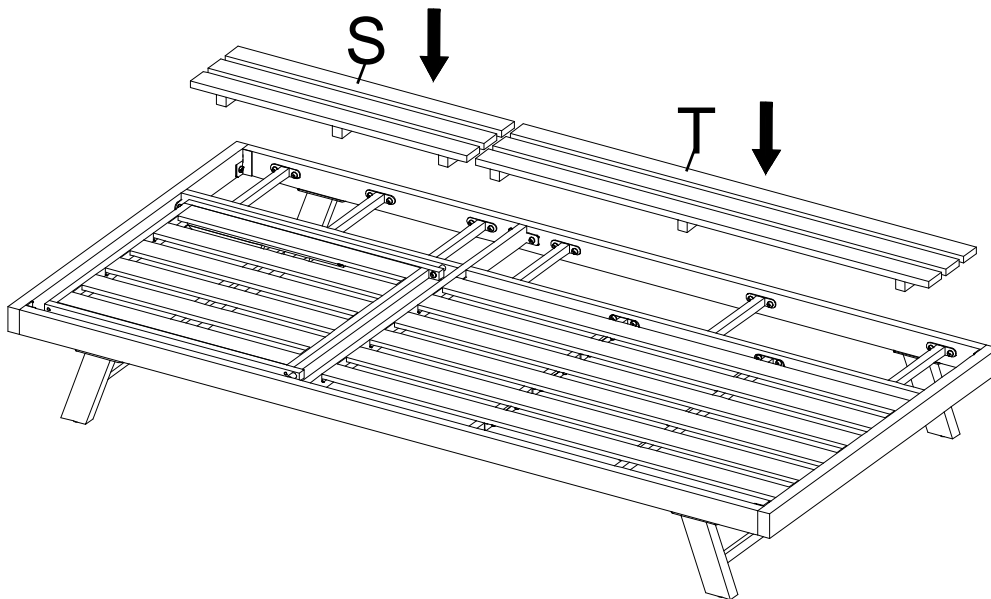

From Step 15. Attach the Wooden Seat Slat (S) and Wooden Backrest Slat (T) as shown above.  
**DO NOT** fully tighten the Bolts at this time.

## Step 17

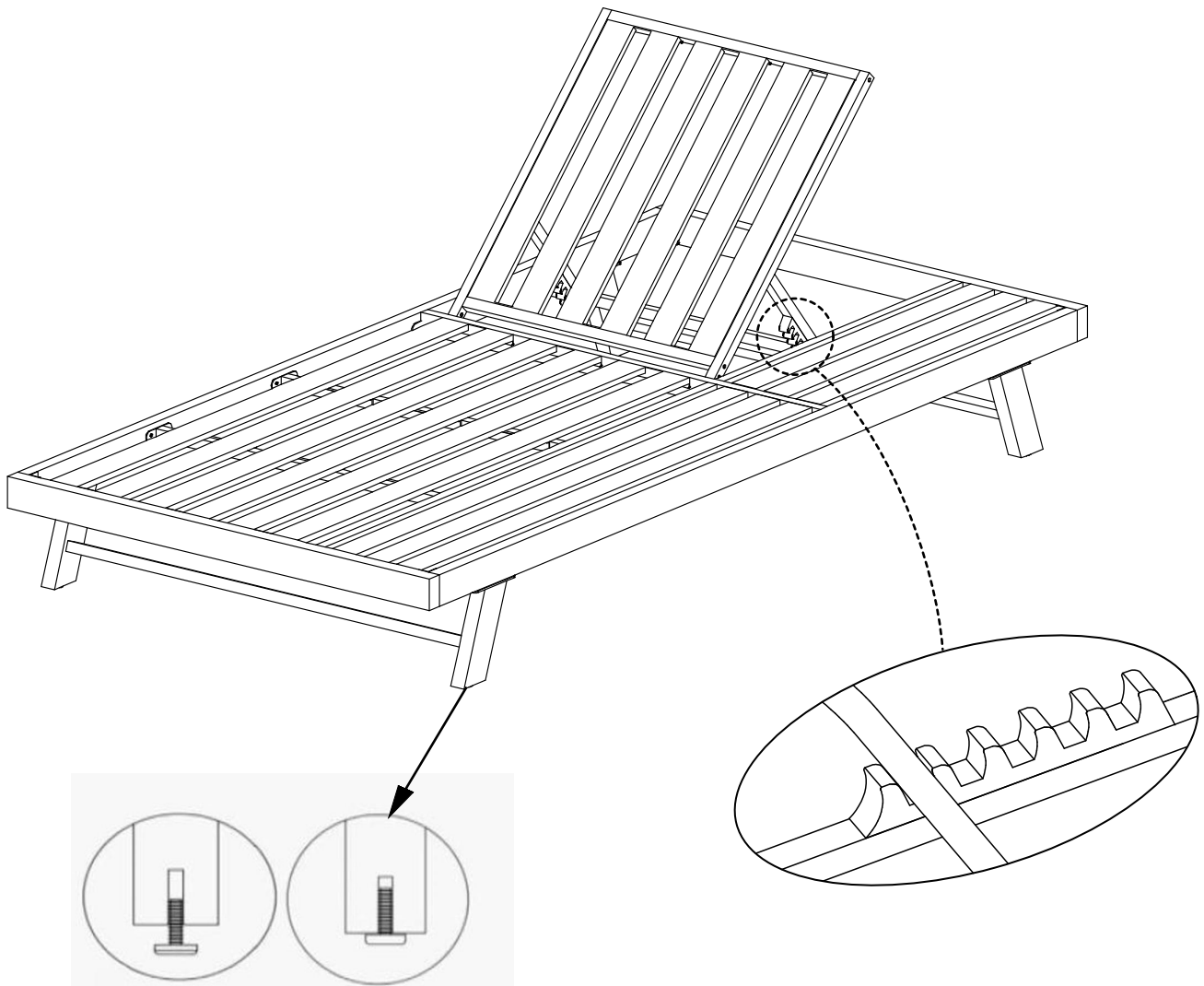

Adjust height for balance    Adjust low balance

Adjust Pre-installed Levellers height for blance



With assistance from your adult partners, turn the Chaise Lounge back to normal flat ground.

Place the Chaise Lounge on a LEVEL surface.

Inspect it and make sure all parts are adequately connected.

Check for wobbles on a LEVEL surface. If no wobbles are found, proceed to tighten the Bolts and Screws in a sequential manner, until evenly secured.

Adjust the Levelers until the Chaise Lounge is level with the ground.

To adjust the Levelers, get assistance from an adult partner to lift/lean and hold the Chaise Lounge while you are working.

Your Chaise Lounge is ready for use.

This Chaise Lounge can only be used on a flat, level surface.

## Questions & Answers about Proposition 65

- What is Proposition 65?

Proposition 65 requires businesses to provide warnings to Californians about significant exposures to chemicals that cause cancer, birth defects or other reproductive harm. These chemicals can be in the products that Californians purchase, in their homes or workplaces, or that are released into the environment. By requiring that this information be provided, Proposition 65 enables Californians to make informed decisions about their exposures to these chemicals. Proposition 65 also prohibits California businesses from knowingly discharging significant amounts of listed chemicals into sources of drinking water.

Proposition 65 requires California to publish a list of chemicals known to cause cancer, birth defects or other reproductive harm. This list, which must be updated at least once a year, has grown to include approximately 900 chemicals since it was first published in 1987.

- What types of chemicals are on the Proposition 65 list?

The list contains a wide range of naturally occurring and synthetic chemicals that include additives or ingredients in pesticides, common household products, food, drugs, dyes, or solvents. Listed chemicals may also be used in manufacturing and construction, or they may be byproducts of chemical processes, such as motor vehicle exhaust.

- What does a warning mean?

If a warning is placed on a product label or posted or distributed at a workplace, a business, or in rental housing, the business issuing the warning is aware or believes that it is exposing individuals to one or more listed chemicals.

By law, a warning must be given for listed chemicals unless the exposure is low enough to pose no significant risk of cancer or is significantly below levels observed to cause birth defects or other reproductive harm.

- Where can I get more information on Proposition 65?

If you have specific questions on the administration or implementation of Proposition 65, you can contact OEHHA's Proposition 65 program at [P65.Questions@oehha.ca.gov](mailto:P65.Questions@oehha.ca.gov), or by phone at (916) 445-6900.