

1-Drawer Coffee Table

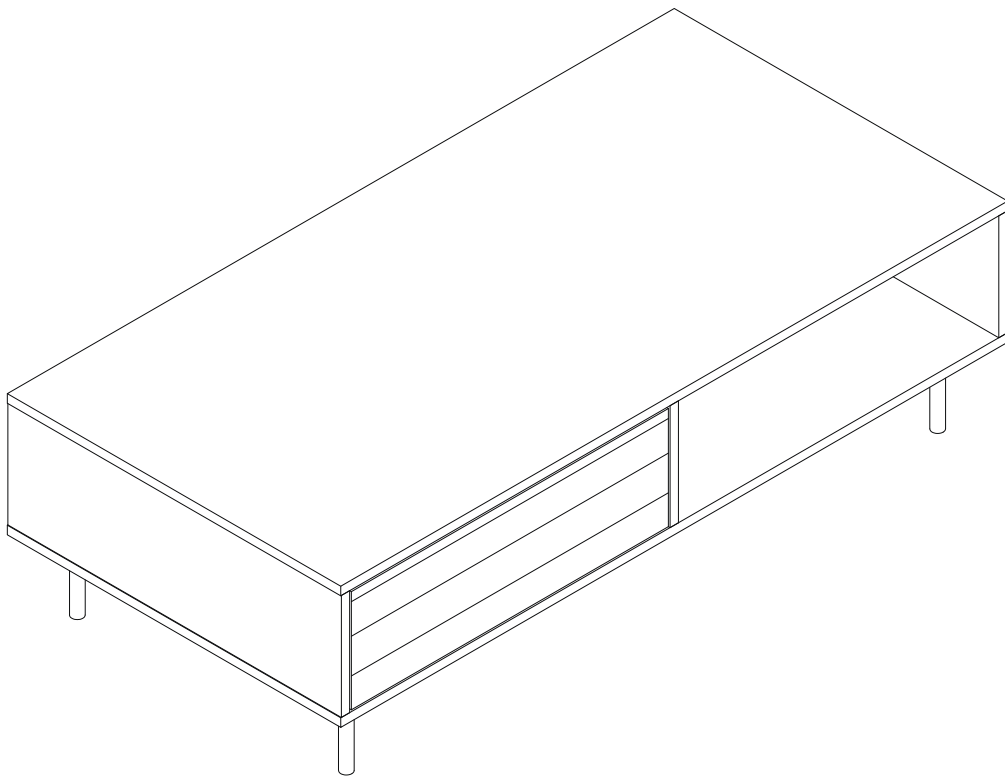

ASSEMBLY INSTRUCTIONS



60 min. assembly

2 person

*The estimated assembly time may vary depending on the individual.

Hey, there

Now is assembly time!

Deeeeeeep breathe.... and again....
Tools ready,
Easy peasy!

Estimated



60 min. assembly
2 person

Tools Required

- Allen Wrench (included)
- Phillips screwdriver (not included)
- Power Drill (not included)

important: *Cautious when you use power tools*

Thank you for purchasing this LuxenHome product. This product has been manufactured with the highest standards of safety and quality.

PLEASE READ ALL INSTRUCTIONS CAREFULLY BEFORE ASSEMBLY.

Un pack all parts from the packaging inside the carton to ensure there are no missing or damaged parts. Lay out all the parts on a clean, flat, and soft surface to prevent scratches. Refer to the steps provided as assembling guide.

Do not attempt to assemble or use the product if any parts are missing or damaged.

REMINDERS

SAFE USAGE IS KEY

Your well-being is our top priority when you use our product. Please prioritize your safety by diligently following the assembly guidelines and inspecting the product carefully both when it arrives and before each use.

Please be aware that LuxenHome and Winsome House, Inc. cannot be held liable for any injuries or fatalities that occur due to not adhering to the provided instructions or misuse of the product.

DO NOT MODIFY

Our products undergo rigorous testing to ensure they meet established safety standards before being released for sale. Altering the product in any way can lead to serious safety concerns, for which LuxenHome cannot assume responsibility.

What's in the box

Parts

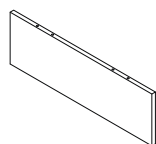

1 X 1

Left side panel

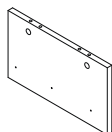

2 X 1

Middle support panel

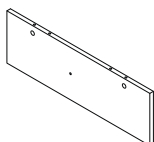

3 X 1

Right side panel

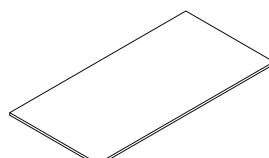

4 X 1

Top panel

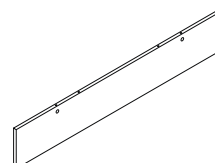

5 X 1

Back panel

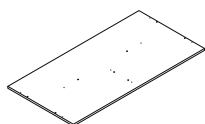

6 X 1

Bottom panel



7 X 4

Metal leg

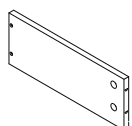

8 X 1

Left drawer side panel

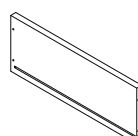

9 X 1

Right drawer side panel

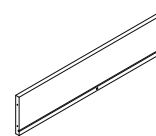

10 X 1

Drawer back panel

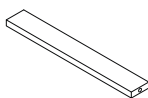

11 X 1

Drawer support bar

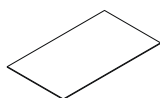

12 X 1

Drawer bottom panel

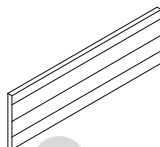

13 X 1

Drawer front panel



14 X 1

Center adjustable metal leg

Hardware & Accessory



A X 15+2

M6 x 36mm



B X 15+2

M15 x 9mm



C X 16+2

M5.8 x 30mm

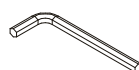

D X 1



E X 12+2

M3.5 x 12mm

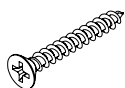

F X 8

M4 x 35mm

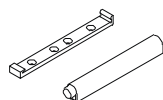

G X 1



H X 20+3

M6 x 12mm

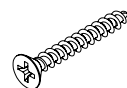

I X 5

M4 x 30mm



J X 2

M3 x 12mm

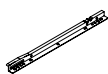

DL X 1

Left inner drawer runner

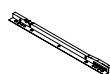

DR X 1

Right inner drawer runner



CL X 1

Left outer drawer runner

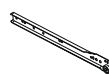

CR X 1

Right outer drawer runner

Assembly

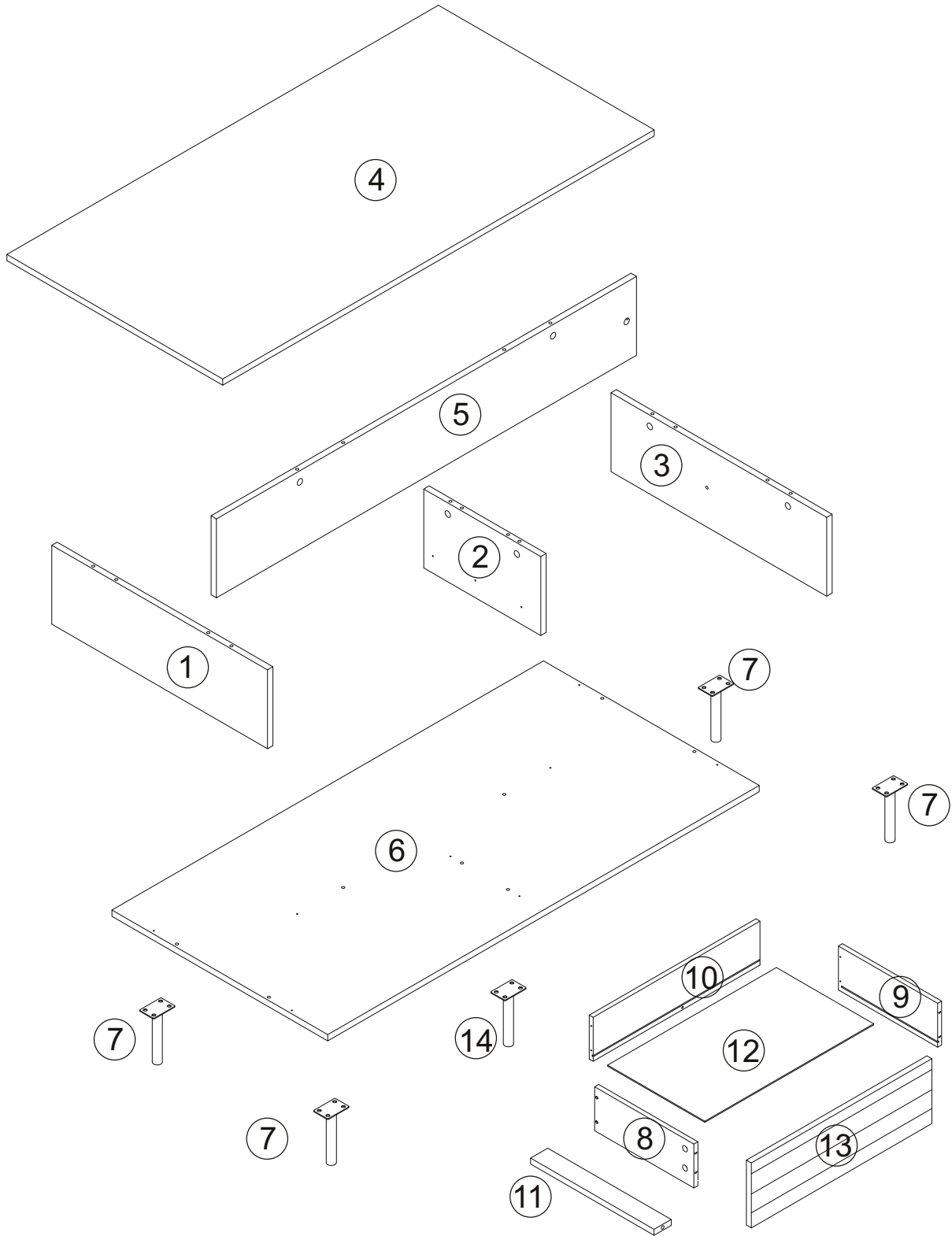

Step 1

Insert quickfit screw (A) into part 1, as shown. Fix left outer drawer runner (CL) and right outer drawer runner (CR) to parts 1 and 2 using screws (E), as shown.

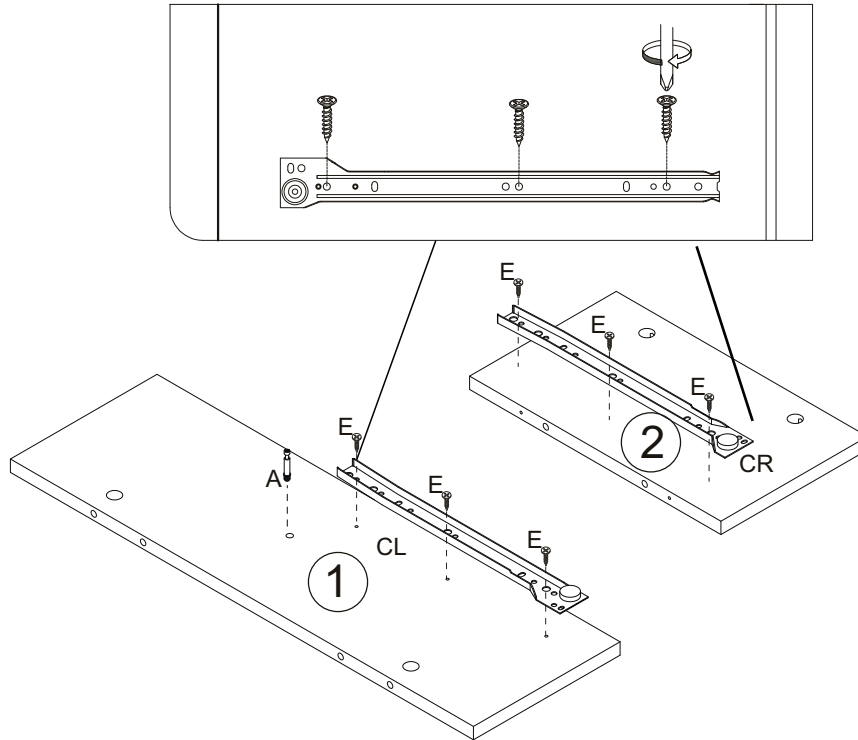

Ax1
M6 x 36mm
CRx1
CLx1
Ex6
M3.5 x 12mm

Step 2

Insert quickfit screws (A) into parts 3 and 4, as shown.

Fix door opener (G-1) to part 4, as shown.

Insert catch (G-2) into opener (G-1), as shown.

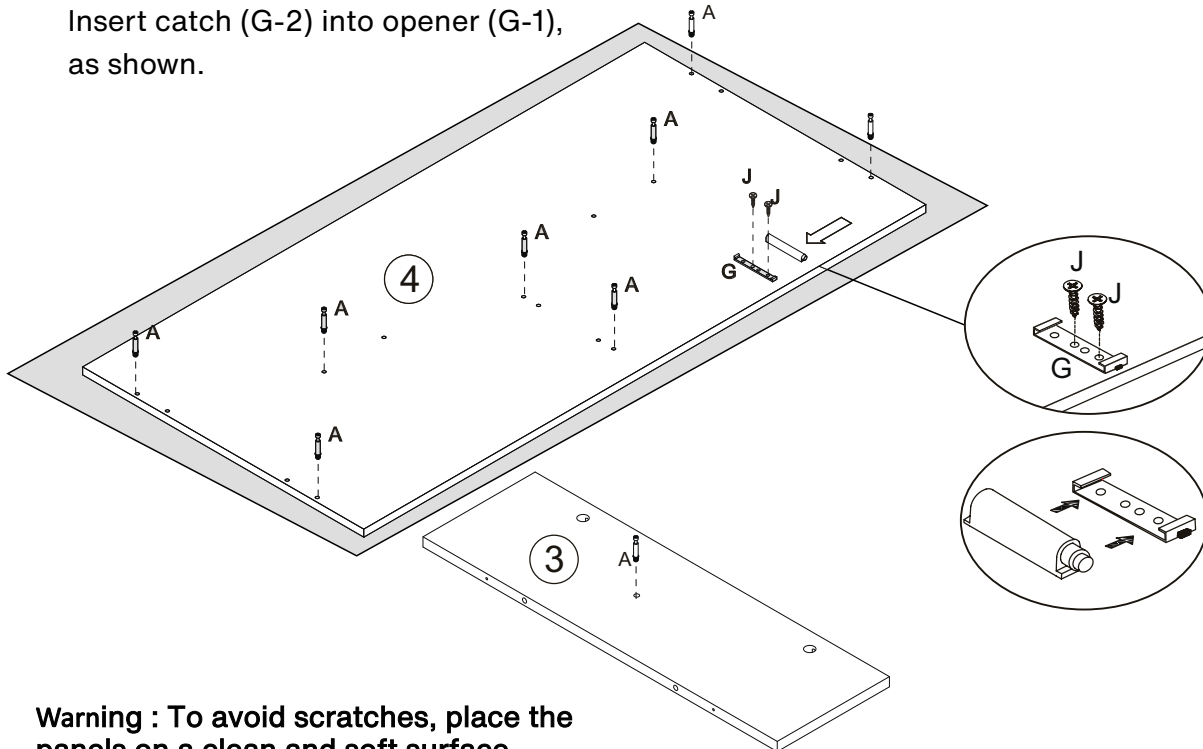

Ax9
M6 x 36mm
Gx1
Jx2
M3 x 12mm

Warning : To avoid scratches, place the panels on a clean and soft surface.

Step 3

Insert cam locks (B) into part 5, as shown.

Fit parts 1 and 3 to part 5.

Turn cam locks clockwise to tighten.

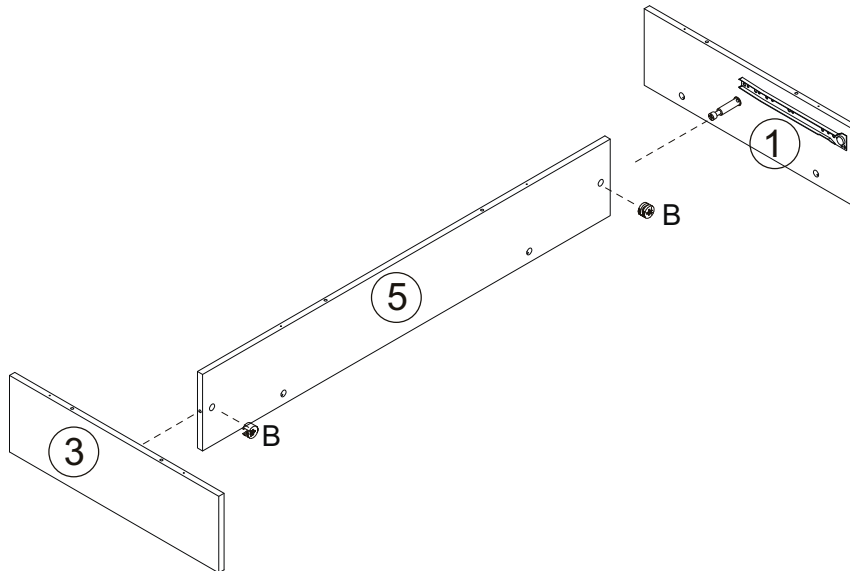
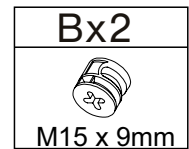

Step 4

Insert cam locks (B) and wooden dowels (C) into parts 1, 2, 3 and 5, as shown.

Fit parts 1, 2, 3 and 5 to part 4.

Turn cam locks clockwise to tighten.

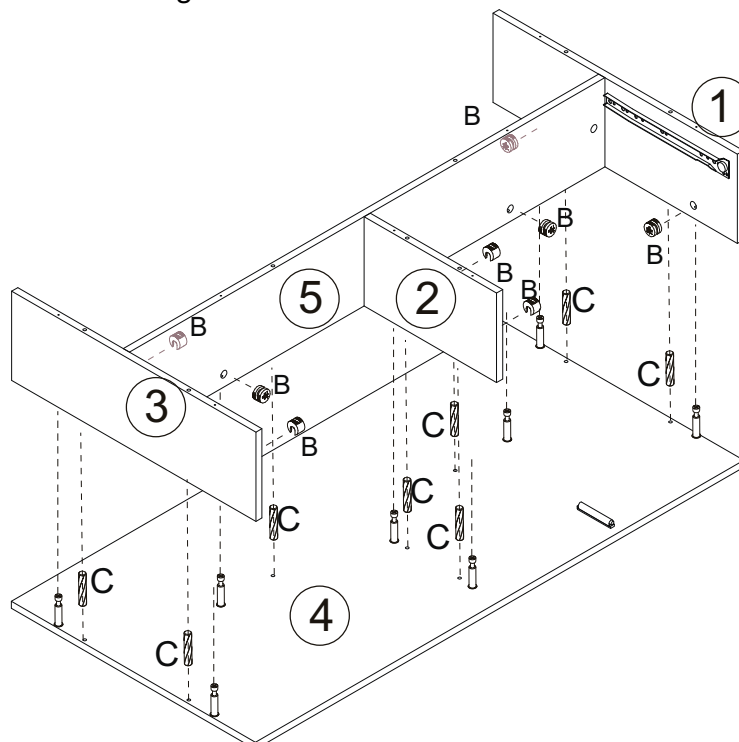
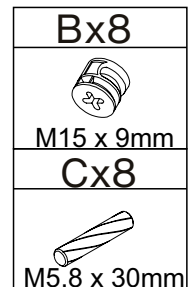

Step 5

Insert wooden dowels (C) into parts 1, 2, 3 and 5.

Fix part 6 to parts 1, 2, 3 and 5 using screws (F).

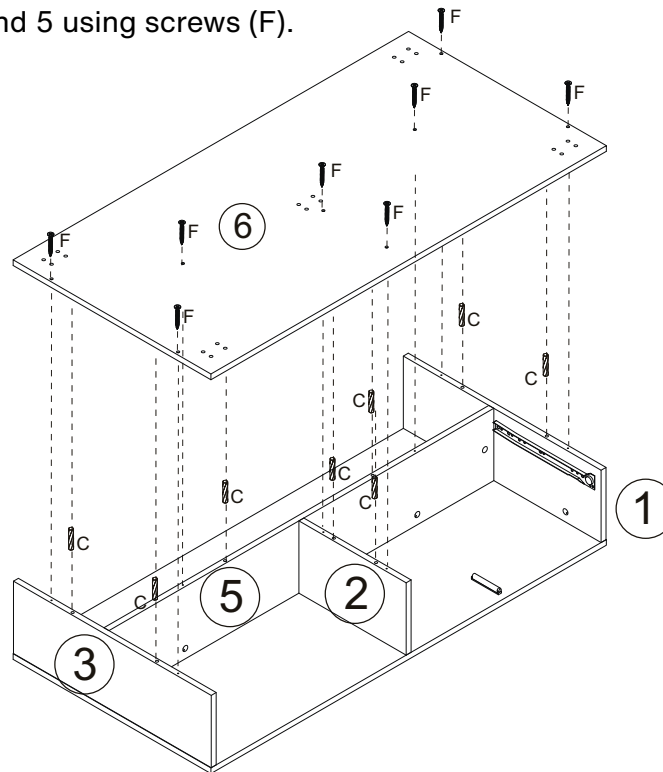

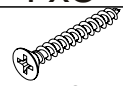
Cx8

M5.8 x 30mm
Fx8

M4 x 35mm

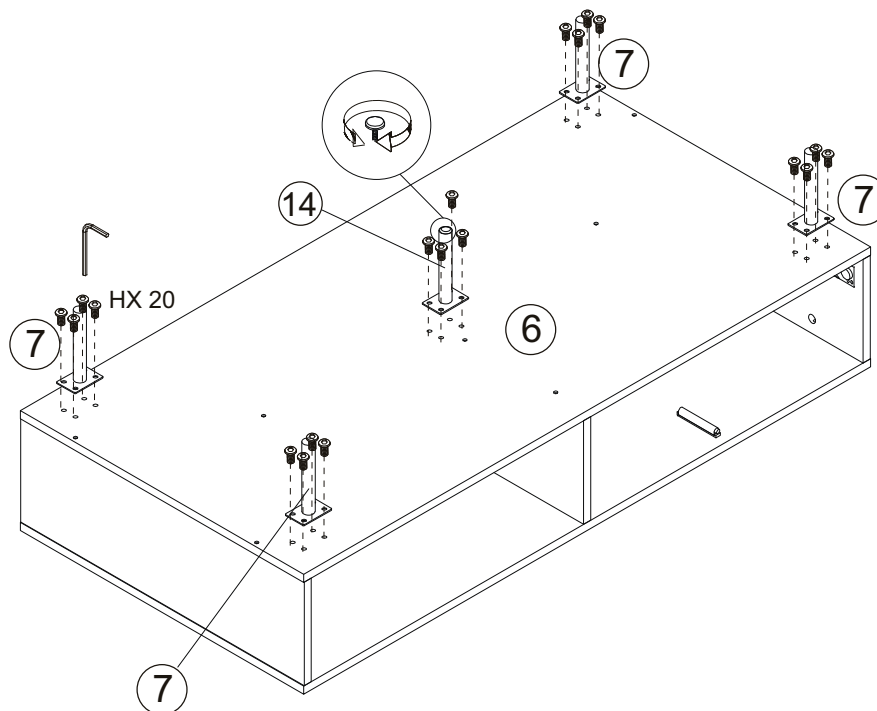
Step 6

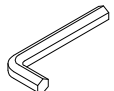
Fix legs 7 and 14 to part 6 using screws (H) and allen key (D), as shown.





Hx20

M6 x 12mm
Dx1

Step 7

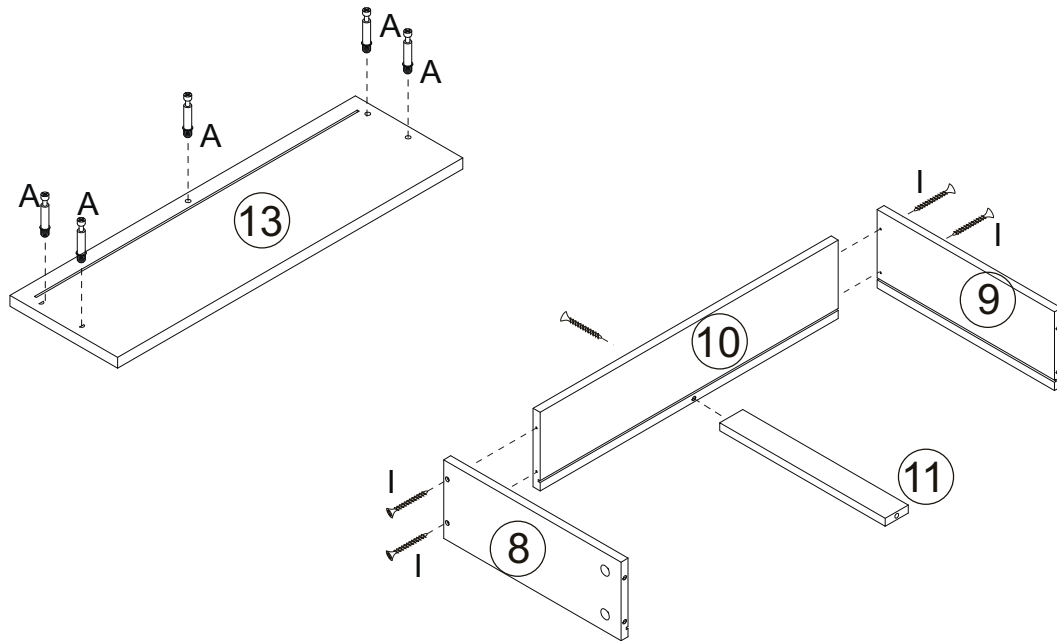
Insert quickfit screw (A) into part 13, as shown.

Fix parts 8, 9 and 11 to part 10 using screws (I), as shown.



Ax5
 M6 x 36mm
Ix5
 M4 x 30mm

Step 8

Insert cam locks (B) into parts 8, 9 and 11.

Insert part 12 into grooves between parts 8, 9 and 10.

Fit part 13 to parts 8, 9, 11 and 12.

Turn cam locks clockwise to tighten.

Bx5
 M15 x 9mm

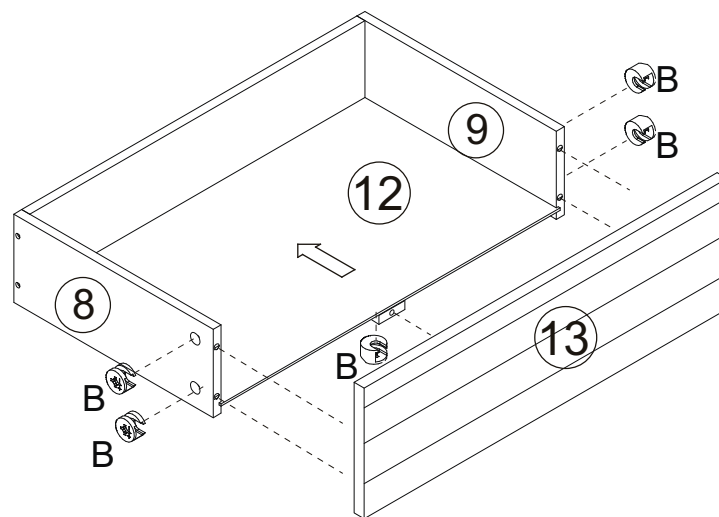

Step 9

Fix right inner drawer runner (DR) and left inner drawer runner (DL) to parts 8 and 9 using screws (E), as shown.

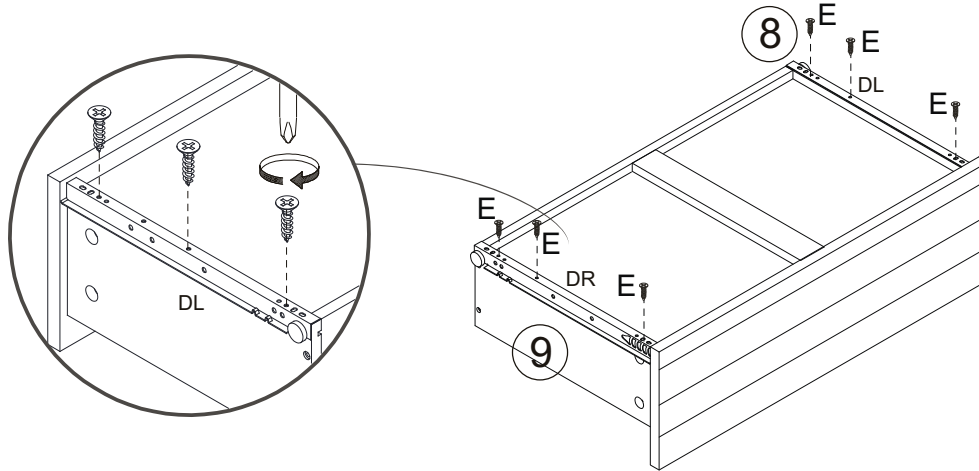

DRx1
DLx1
Ex6
 M3.5 x 12mm

Step 10

Insert drawer to assembled unit, as shown.

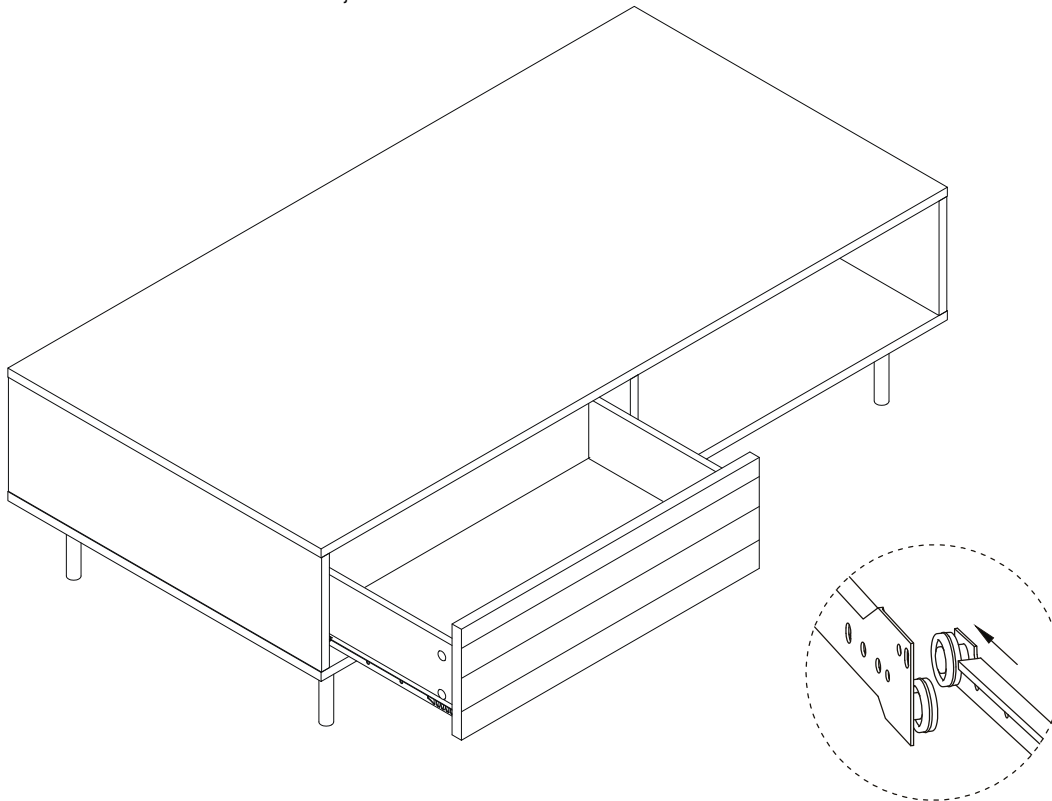

VOILA!
Now enjoy.

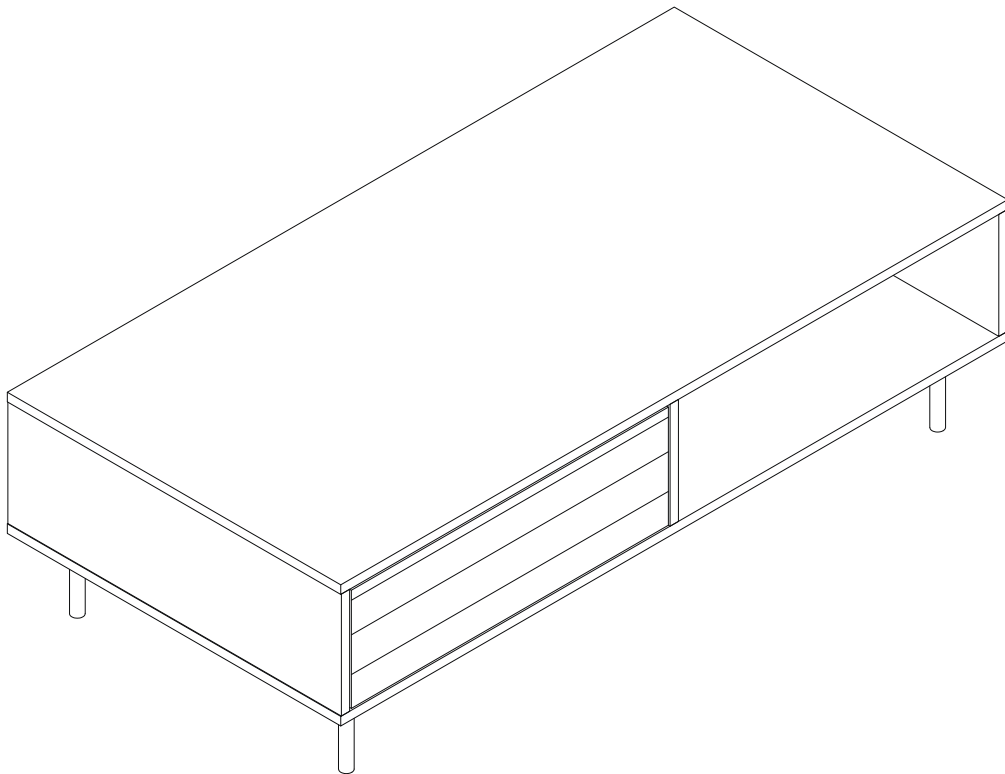

Warning

DO NOT sit or stand on the Coffee table as this may damage the product and cause serious bodily injury.

Something not right?

We are always here to help.

We make mistakes like every human does.

Though we always strive to provide the best possible products at competitive prices and the best service in the industry, it's not possible to completely eliminate mistakes. If you experience any dissatisfaction, feel free to contact us immediately. Our in-house customer care team will respond ASAP.

Things to do to expedite the process

- Have your order# ready
- Take photos/videos to help us better identify the issues
- DO NOT throw away the packaging