

# Installation & Assembly

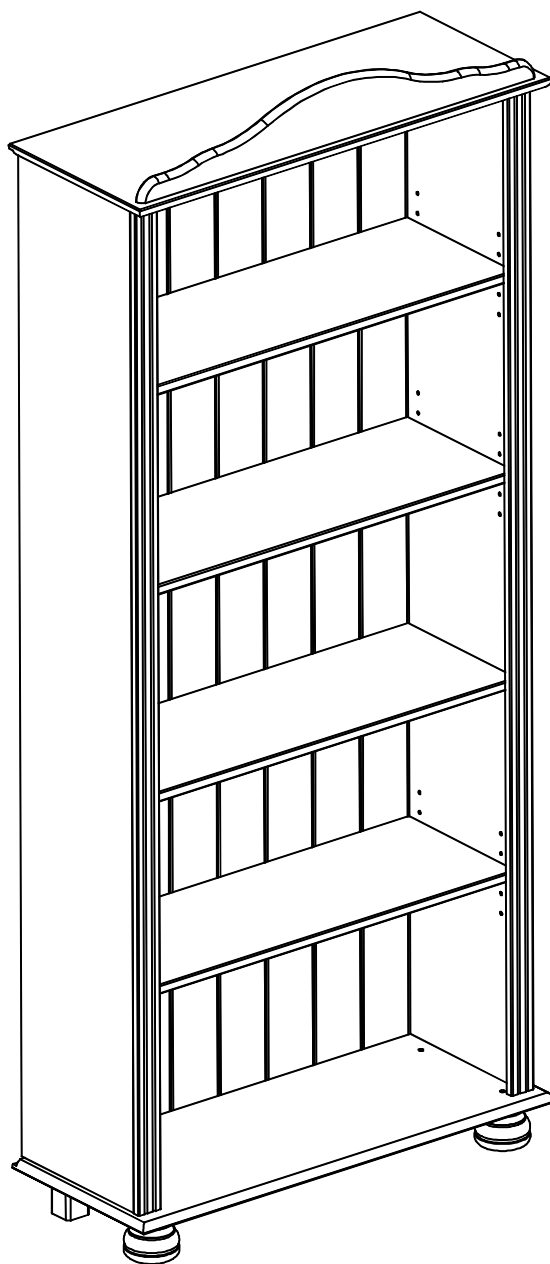

- |   |                                     |
|---|-------------------------------------|
| <b>(D)</b> Montageanleitung             | <b>(GB)</b> Assembly Instructions   |
| <b>(FR)</b> Notice de montage           | <b>(IT)</b> Istruzioni di montaggio |
| <b>(NL)</b> Handleiding voor de montage | <b>(PL)</b> Instrukcja montażu      |
| <b>(CZ)</b> Montážní návod              | <b>(SK)</b> Návod na montáž         |
| <b>(HU)</b> Szerelési útmutató          | <b>(RO)</b> Instrucțiuni de montaj  |
| <b>(TR)</b> Montaj talimatı             | <b>(RU)</b> ИНСТРУКЦИЯ ПО МОНТАЖУ   |

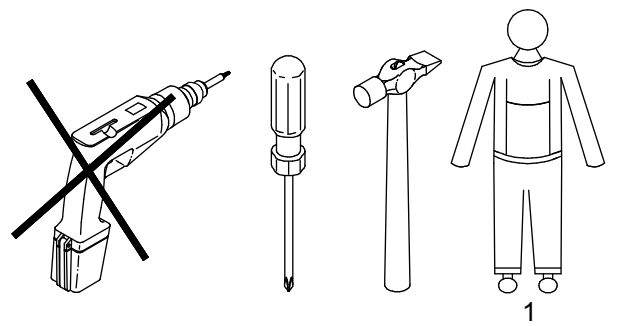
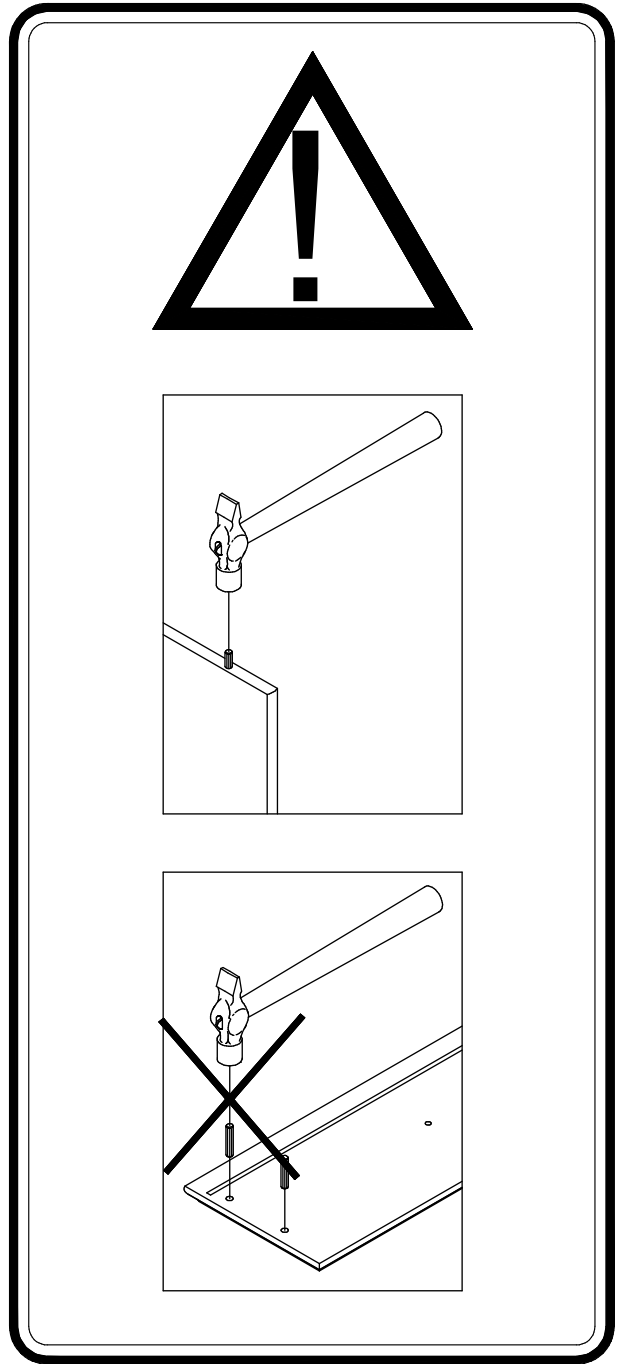
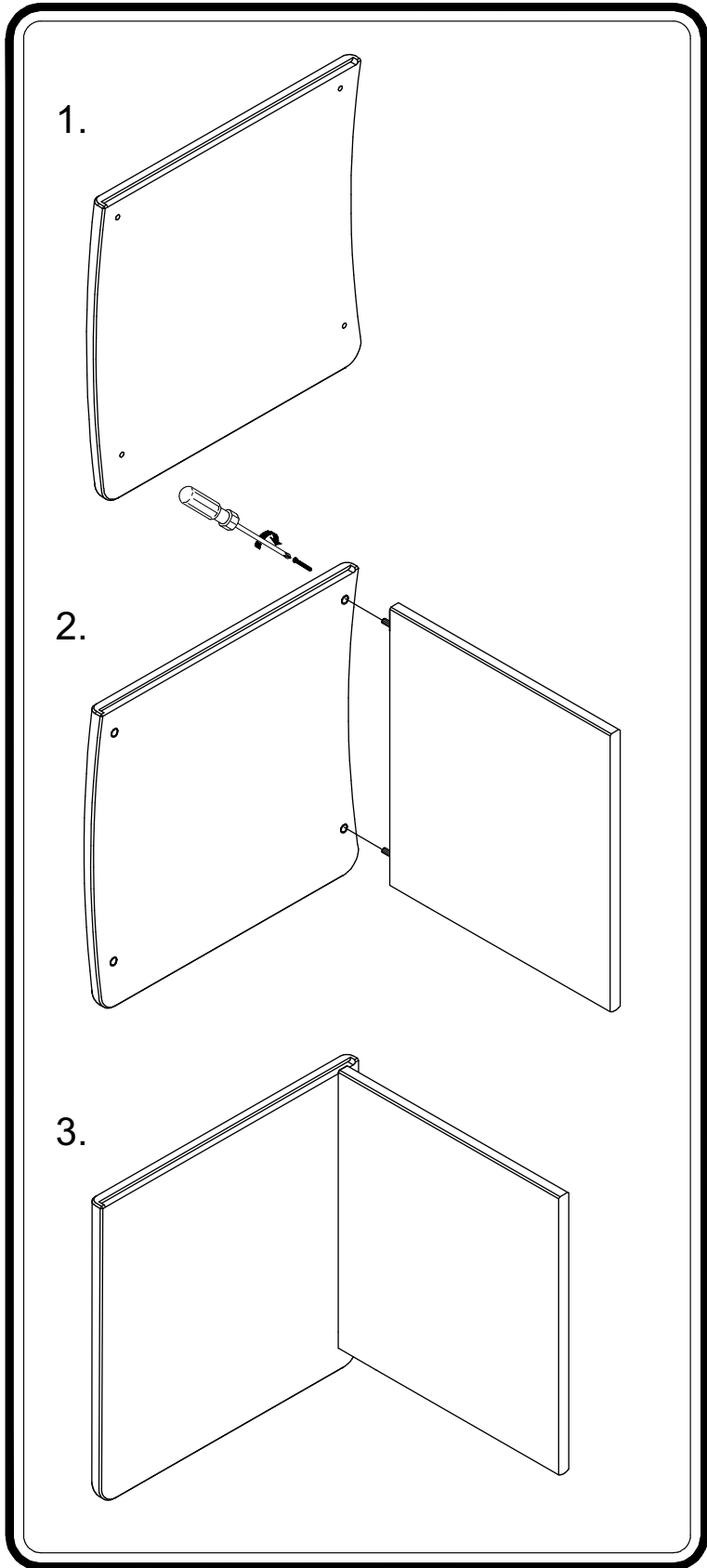

**Service • Assistenza • Dienstverlening • Serwis  
Servis • Szerviz • Сервисная служба**



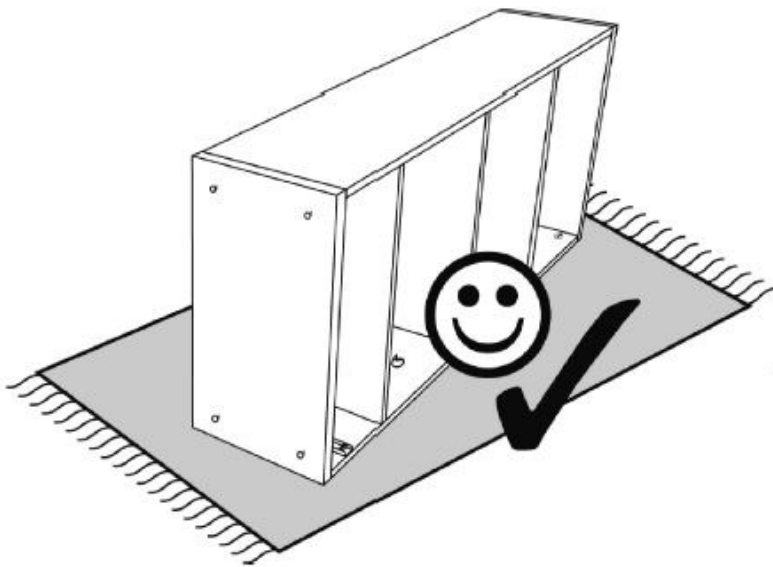
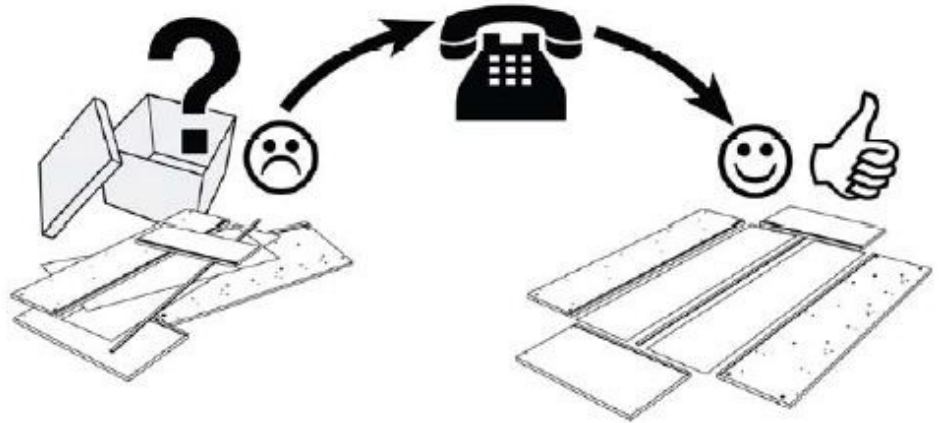
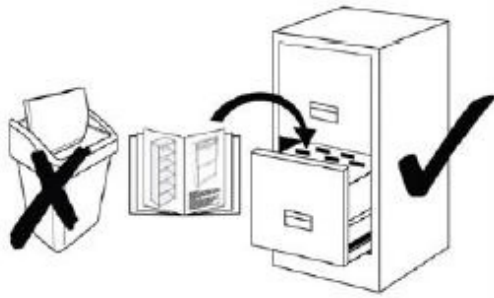

Name • Nom • Nome • Naam •  
Nazwa • Иméно • Názov • Név •  
Denumire • Ísim • Название

Nr. • No. • N° • Номер • Č • Sz

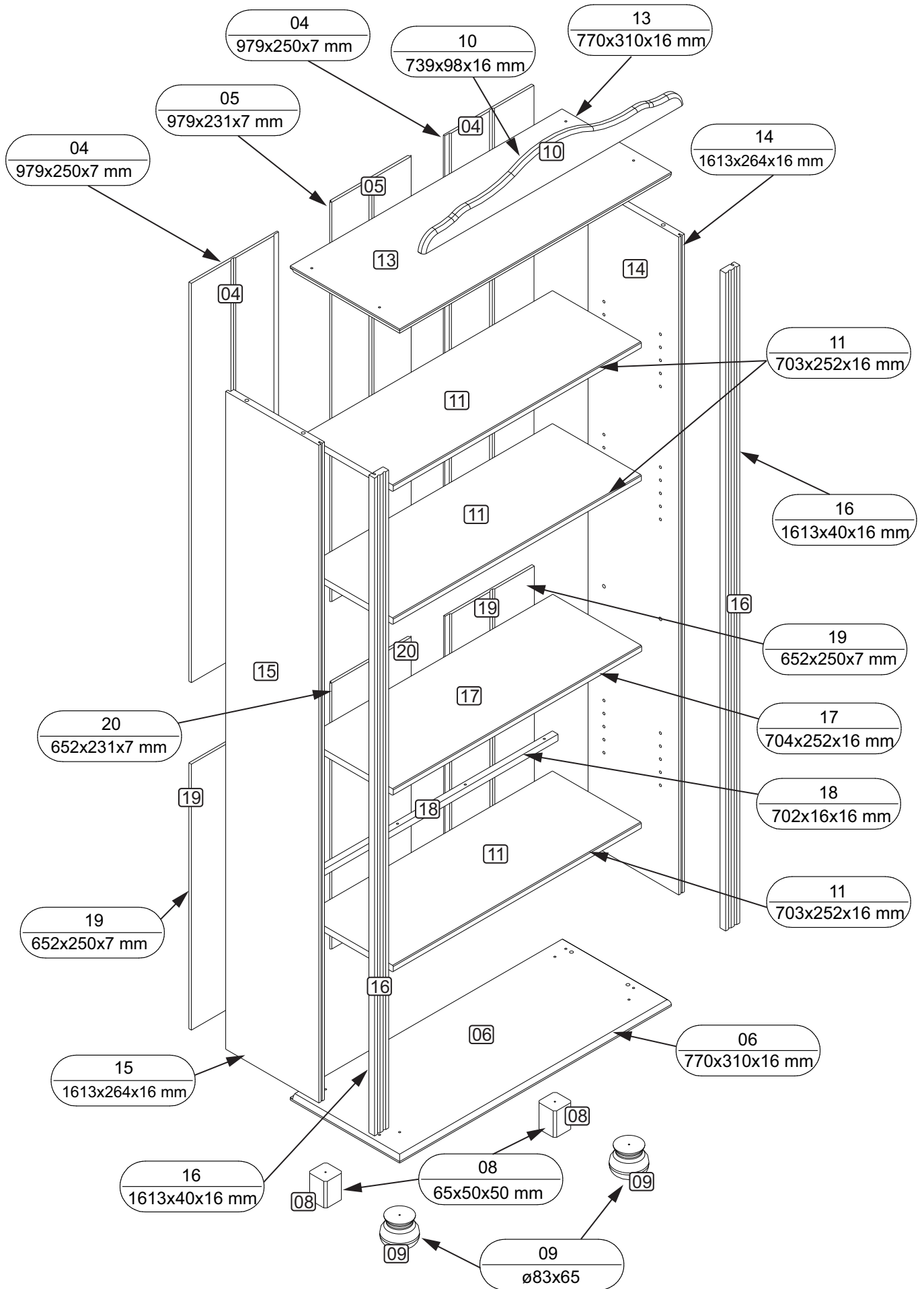
Tур • Type • Tip • Típus • Tipo •  
Тип

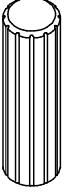
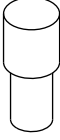
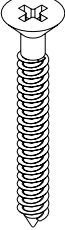
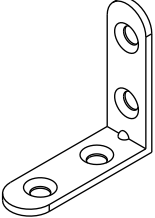
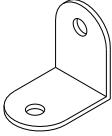
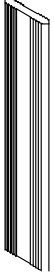
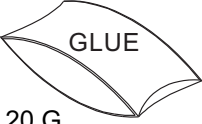

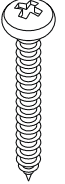

<p><b>A</b> 12 X ø8x25 mm</p> 	<p><b>B</b> 12 X 6/8 mm</p> 	<p><b>C</b> 13 X Ø4,0x40 mm</p> 	<p><b>D</b> 01 X 42x42x2 mm</p> 	<p><b>E</b> 02 X 17x13x1 mm</p> 	<p><b>F</b> 10 X 14,5x80 mm</p> 
<p><b>G</b> 01 X GLUE 20 G</p> 	<p><b>H</b> 05 X Ø3,5x14 mm</p> 	<p><b>J</b> 08 X Ø4,5x25 mm</p> 	<p><b>Z</b> 60 X 10 x 10</p> 		

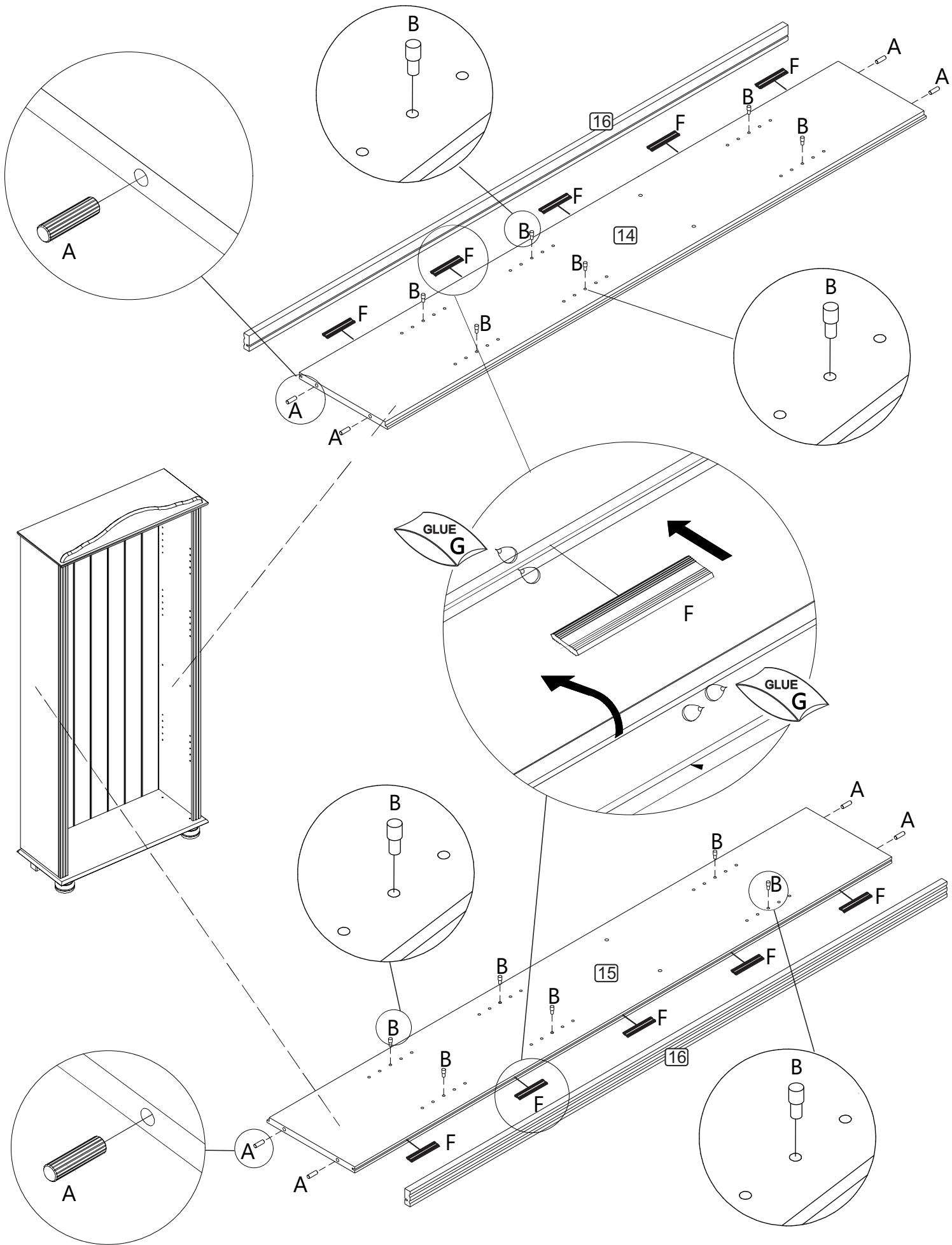

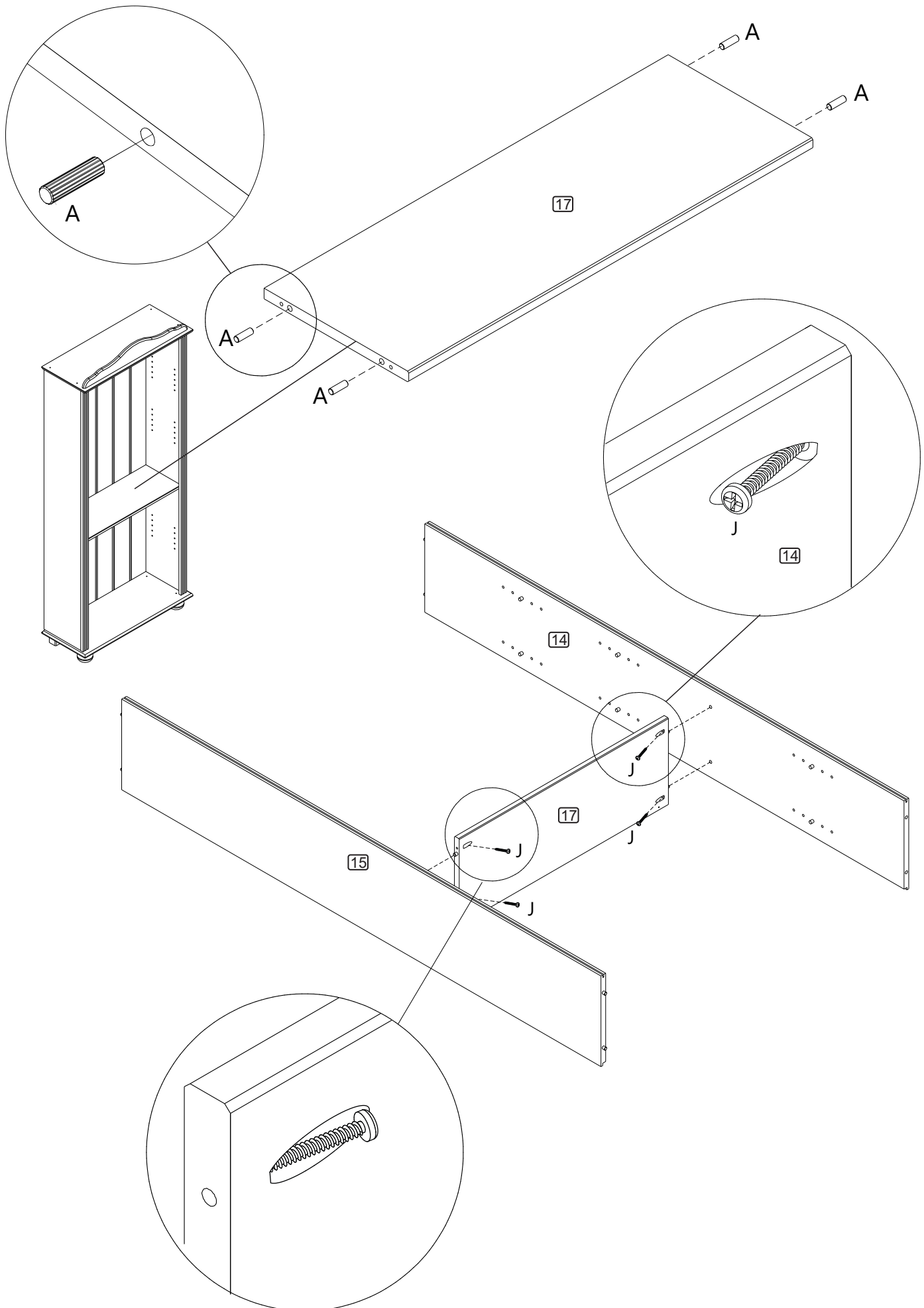

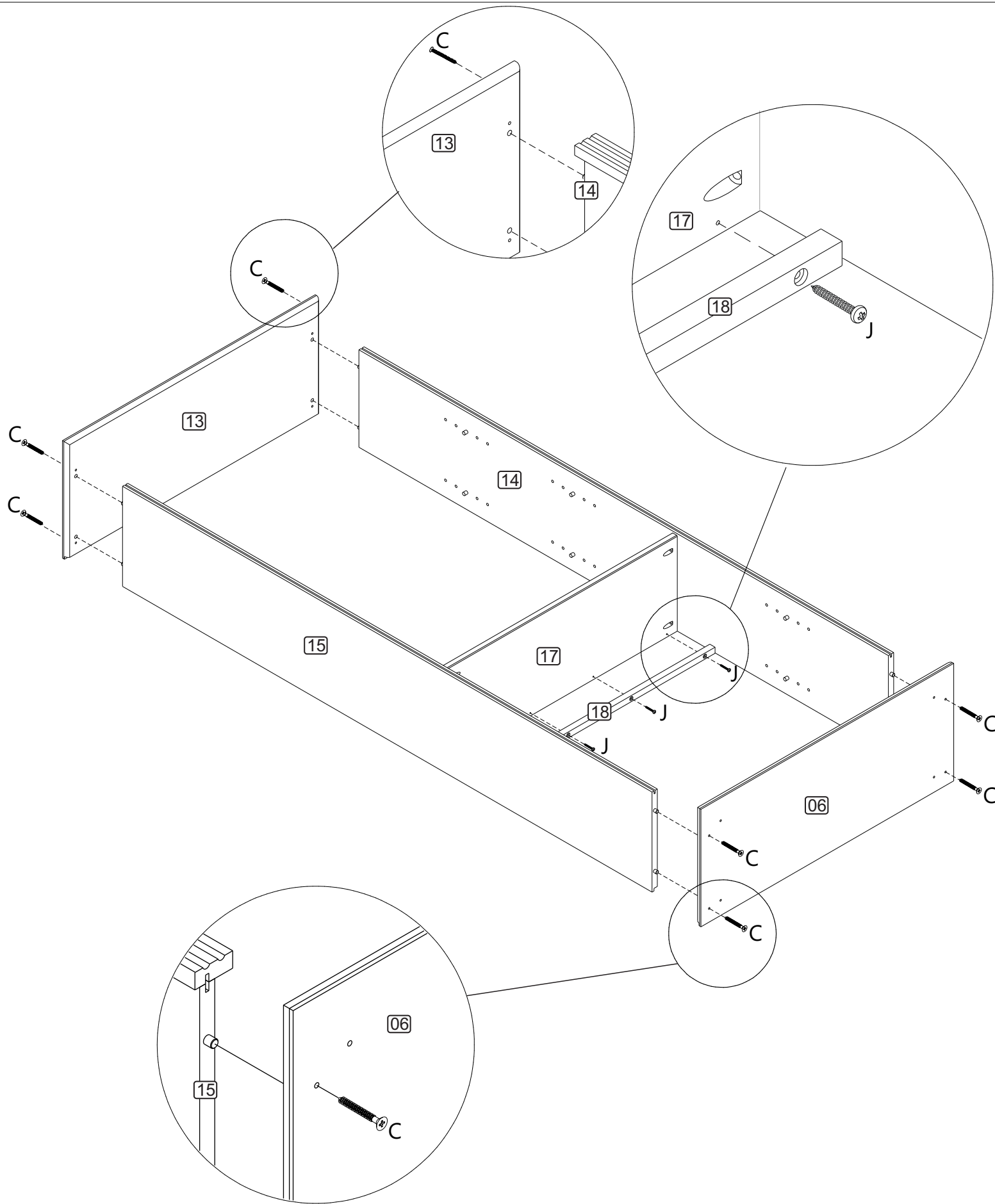

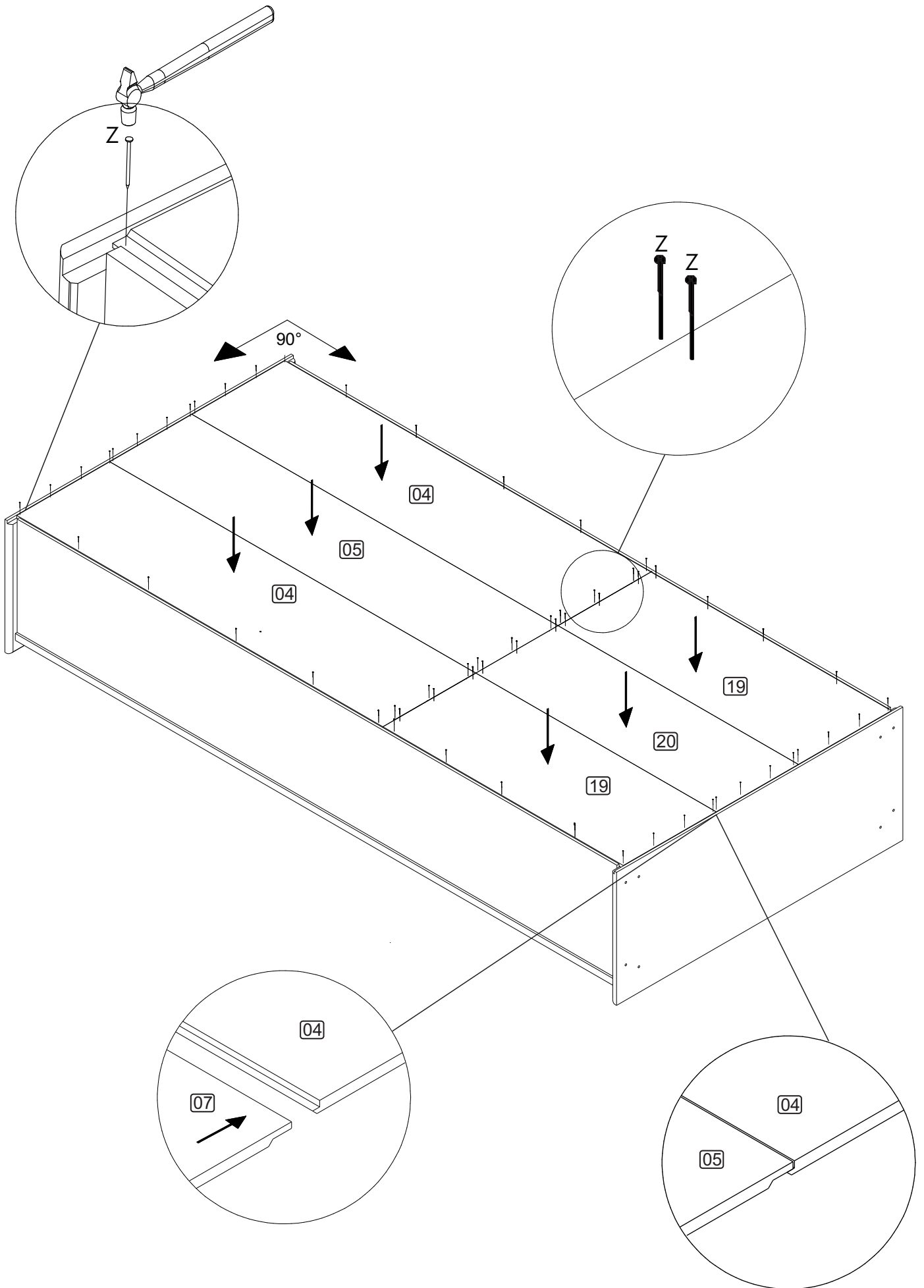

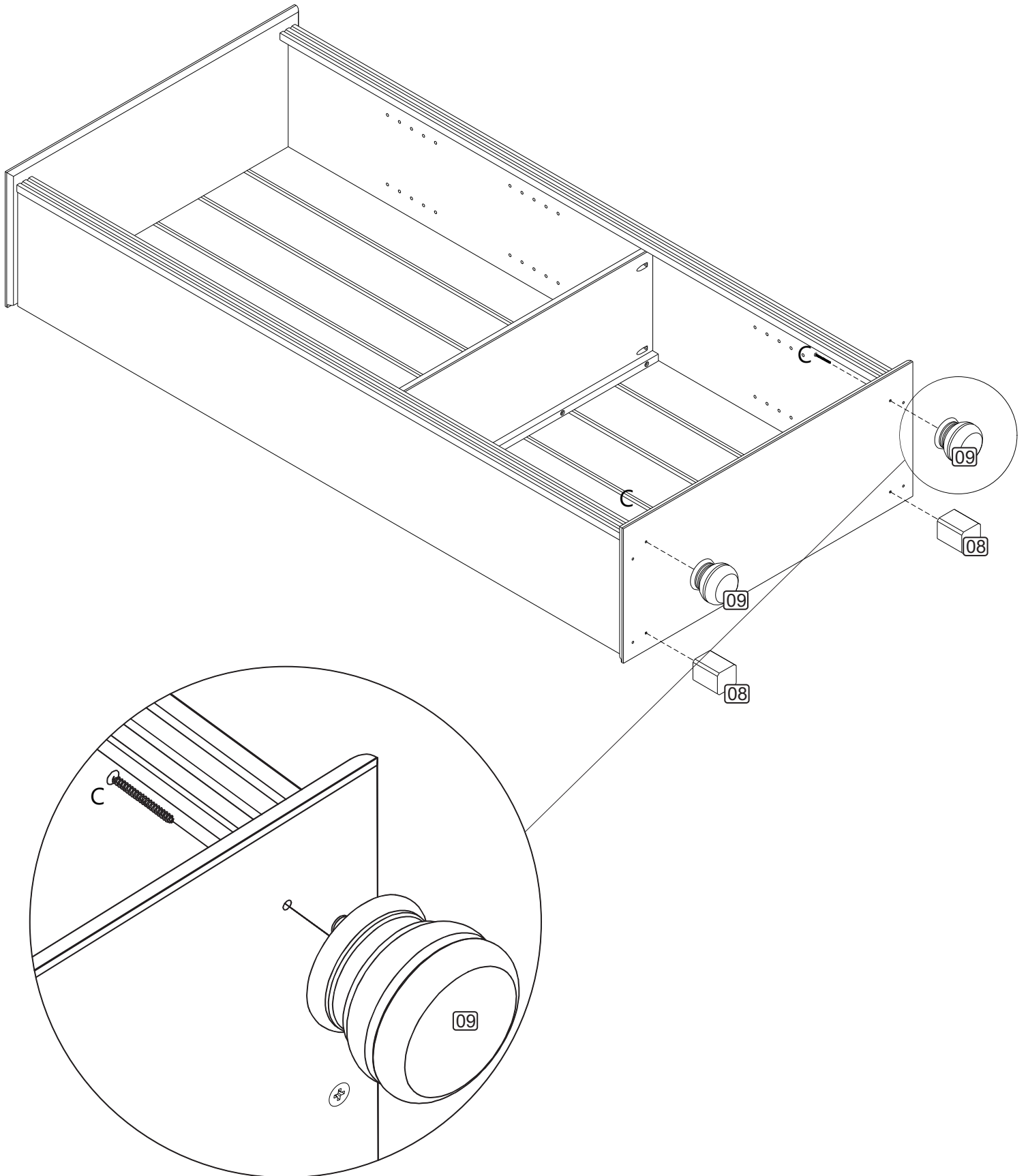

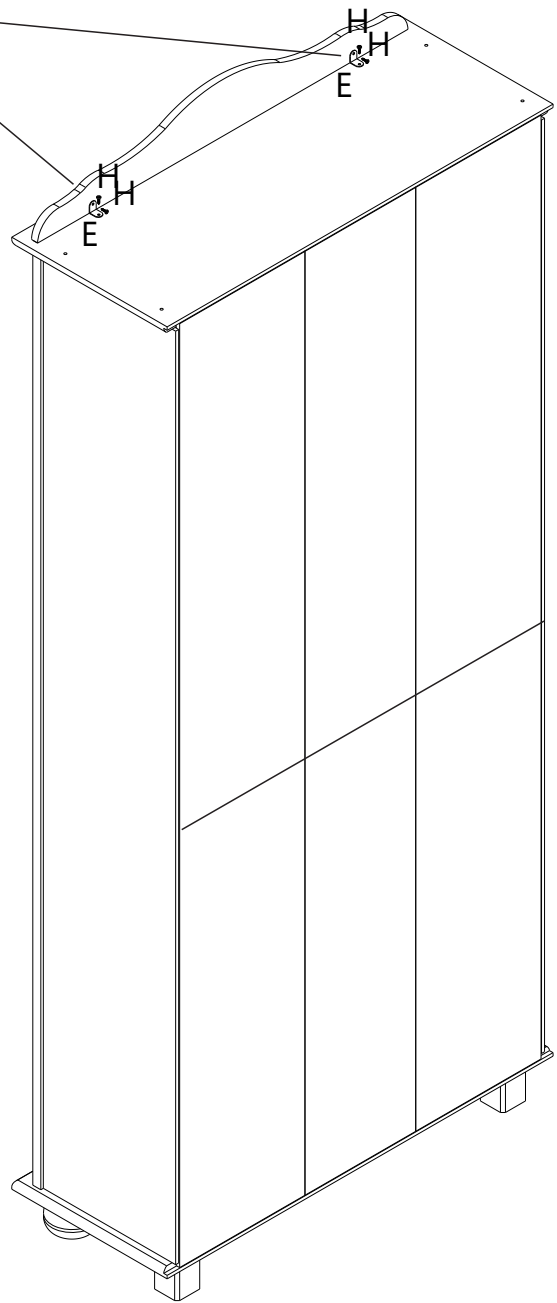
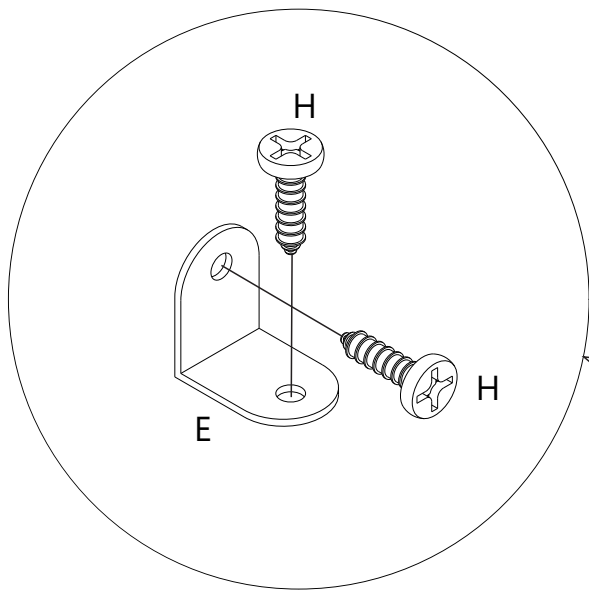

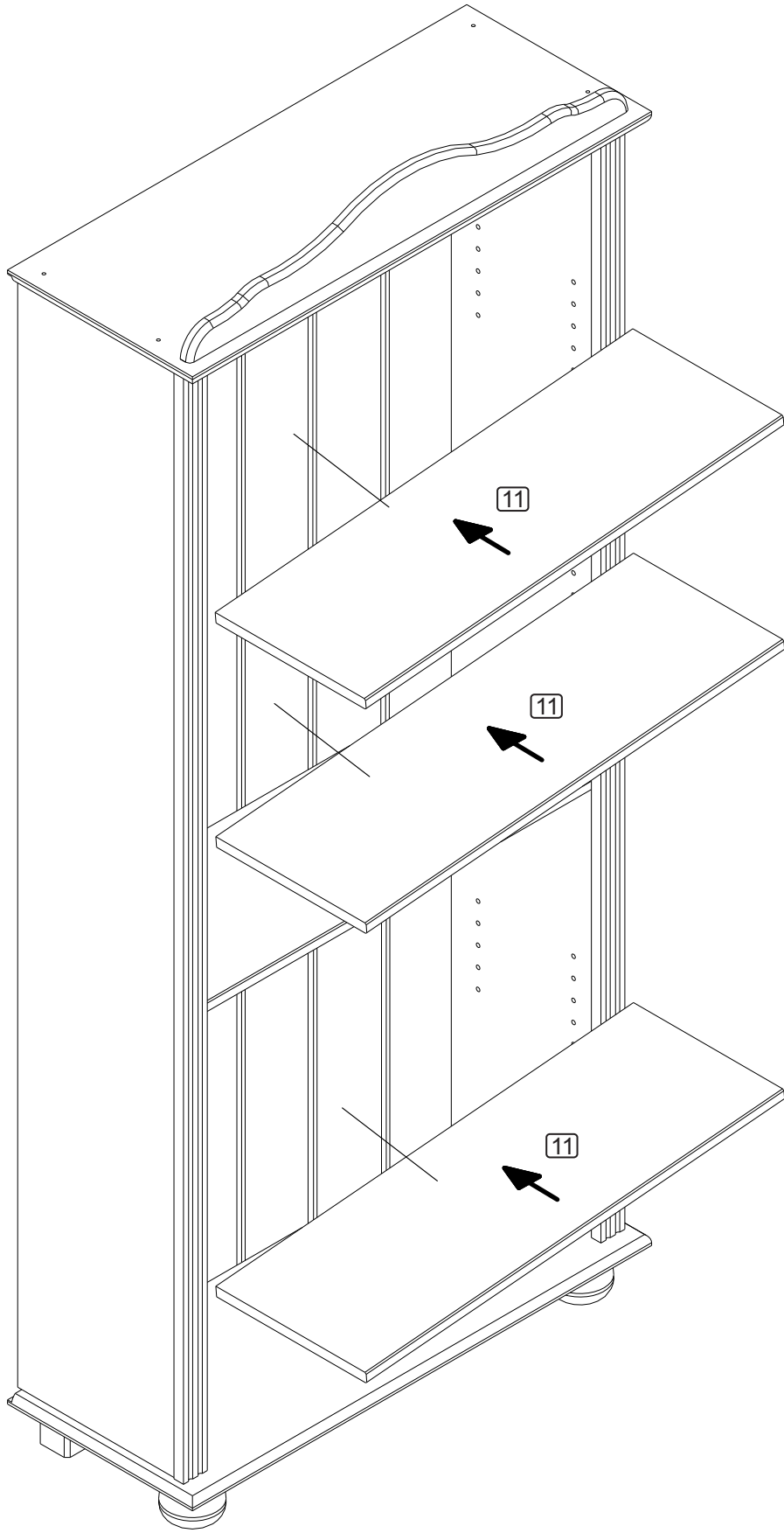

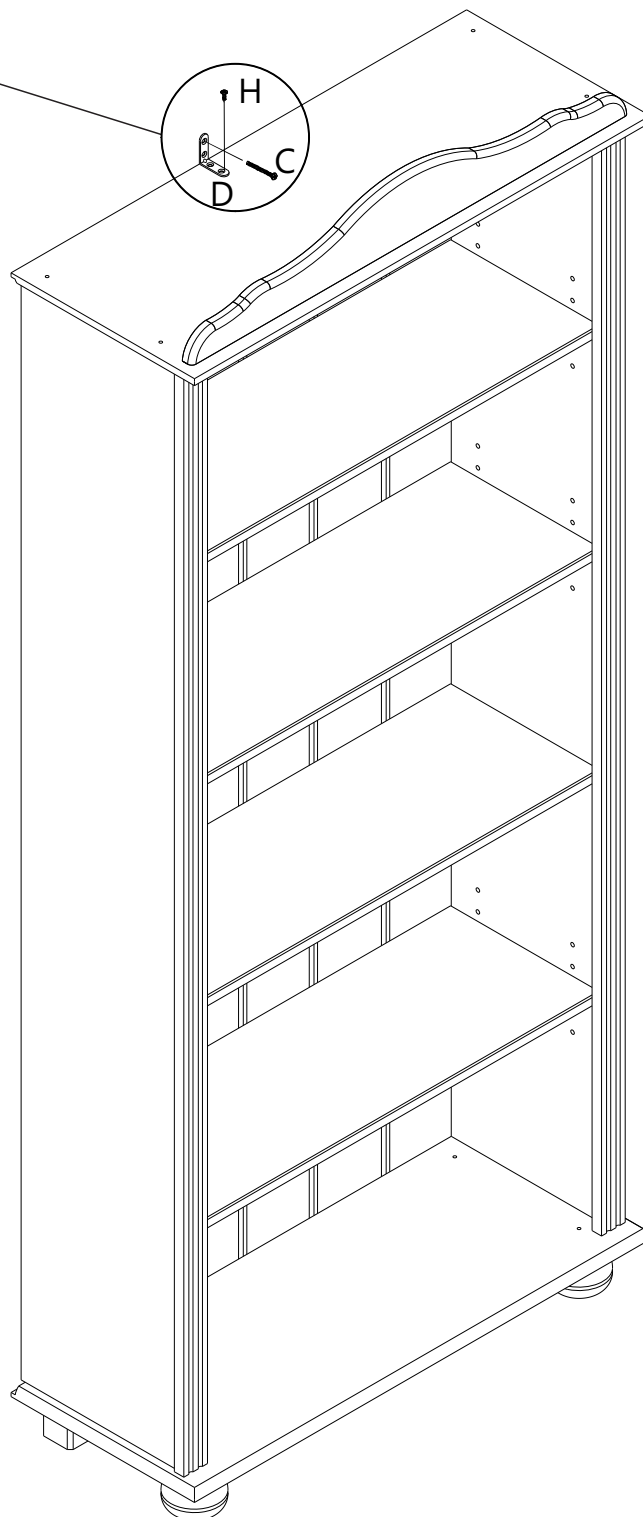
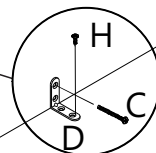
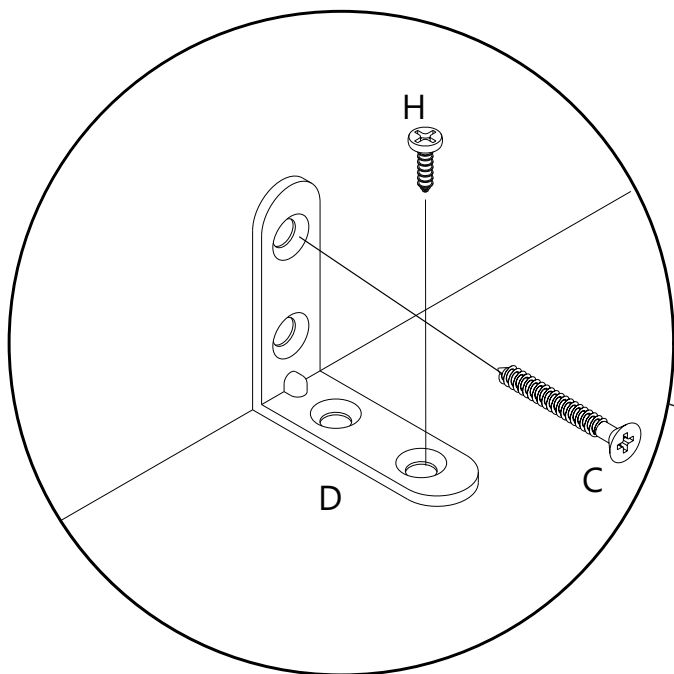

<b>Achtung • Attention • Attenzione</b> <b>Opgelet • Uwaga • Pozor • Figyelem</b> <b>Atenție • Dikkat • Внимание</b>	
<b>(D)</b>	Wandbefestigung dient als Kippschutz – unbedingt anbringen! Bei einigen Wandtypen kann ein Spezialdübel erforderlich sein!
<b>(GB)</b>	The wall fastening serves to prevent tipping – be absolutely sure to mount it! For certain wall types, a special wall plug may be necessary!
<b>(FR)</b>	La fixation murale sert de protection contre le basculement – à installer impérativement ! Pour certains types de murs il faut des chevilles spéciales !
<b>(IT)</b>	Il fissaggio alla parete serve da protezione anti-ribaltamento – attaccarla assolutamente! Per alcune strutture di parete può essere necessario un tassello speciale!
<b>(NL)</b>	Bevestiging aan de muur dient als kantelbescherming – zeker en vast bevestigen! Bij enkele muurtypes is een speciale plug misschien vereist!
<b>(PL)</b>	Mocowanie do ściany jest jednocześnie zabezpieczeniem przed przewróceniem – koniecznie zamontować! Do niektórych rodzajów ścian koniecznie zastosować specjalne kołki mocujące.
<b>(CZ)</b>	Montáž na stěnu slouží jako ochrana proti převrnutí – bezpodmínečně umístěte! U některých typů stěn může být zapotřebí speciální hmoždinka!
<b>(SK)</b>	Upevnenie na stenu slúži ako ochrana proti prevráteniu – bezpodmienečne použite! Pre niektoré druhy stien môže byť potrebná špeciálna hmoždinka!
<b>(HU)</b>	A terméket a falhoz kei rögzíteni, különben az felborulhat! Egyes fal típusoknál speciális tiplőt kell használni!
<b>(RO)</b>	Sistemul de fixare la perete servește ca protecție la răsturnare – de montat obligatoriu! Pentru unele tipuri de pereți este posibil să fie necesar un diblu special!
<b>(TR)</b>	Duvardaki sabitleme, devrilmeye karşı bir emniyet tedbiridir ve mutlaka monte edilmelidir! Bazı duvar tiplerinde bunun için özel bir dübel gerekli olabilir!
<b>(RU)</b>	Обязательно установите крепление на стене во избежание опрокидывания! Для некоторых типов стен может потребоваться специальный дюбель!