



# SPEC SHEET

## KoolMore 45 in. Two-Door Merchandiser Refrigerator - 38 Cu. Ft.

Model: MDR-2GD-35C

### FEATURES

- Customizable top lighted panel and a LED light 2 strips.
- 8 adjustable corrosion resistant shelves.
- External digital temperature control and monitor.
- Anti-fogging system.
- Self-closing glass doors.
- ETL Listed for Safety and Sanitation.



### CLOSE UP IMAGES



# TECHNICAL SPECS

## Dimensions

Length	44.49
Height	79.65
Width	28.35
Interior Depth	23.43
Interior Width	40.66
Interior Height	61.48
Shelf Width	19.88
Shelf Depth	21.73
Depth Excluding Handles	27.16
Depth Including Handles	28.35
Depth Less Door	25.39
Depth With Door Open 90 Degrees	48.9
Minimum Back Air Clearance In	4 in.
Minimum Side Air Clearance In	4 in.
Power Cord Length	98

## Capacity

Gross Cubic Feet	31
Net Cubic Feet	26.8
Individual Shelf Capacity	71.65

## Features & Materials

Door Style	Swing
Number Of Doors	2
Number Of Shelves	8
Defrost Type	Automatic
Refrigerant Type	R-290
Temperature Control Type	
Temperature Range	32-50 F
Ambient Temperature Range	100.4
Light Type	
Casters	4
Interior Material	Galvanized Steel
Exterior Material	Precoated Steel
Shelf Material Type	Coated Metal
Noise	56 db

## Electric & Certifications

Amps	3.3
Phase	1
Voltage	115
Wattage	380
Hertz	60
Plug Type	NEMA 5-15P
Certifications	ETL Listed for Safety and Sanitation

# Plan View

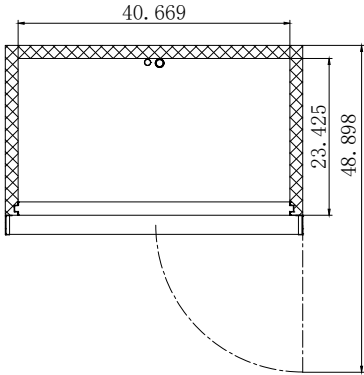
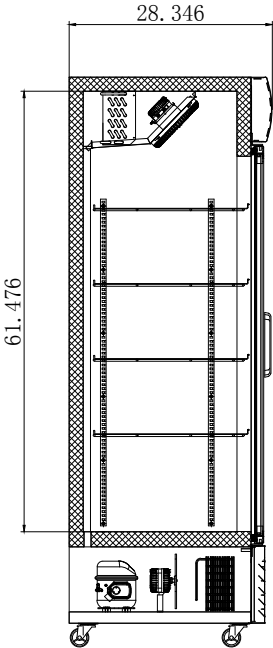
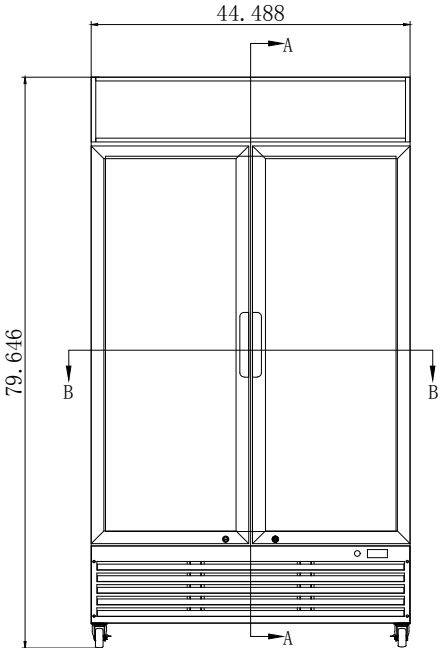

**CERTIFICATIONS**



706 Eastern Parkway STE 1G, Brooklyn NY 11213  
 718-576-6342  
 info@koolmore.com