

ASSEMBLY INSTRUCTIONS FOR WORK & MOBILE TABLE

PART LIST

A	4 LEGS
B	4 LEG EXTENSION
C	1 TOP
D	1 LOWER SHELF
*	24 1/4-20 X 20 X 5/8 BOLTS/NUTS

MODEL FOR WORK TABLE

WT182418	WT243030
WT182430	WT244818
WT243618	WT244830
WT243630	WT243018

HOW TO ASSEMBLE WORK TABLE

- Step 1
Attach 4 Legs to Steel Top. Use (2) ea, 1/4-20 x 5/8 Bolts & nuts in each corner. (See Detail A)
- Step 2
Attach 4 Legs to Lower Shelf. Use (2) 1/4-20 Bolts in each corner.
- Step 3
Attach Leg Extension to each leg, setting position at desired table height. Use 2 bolts for each leg extension for maximum strenght.
- Step 4
Check all bolts for tightness.

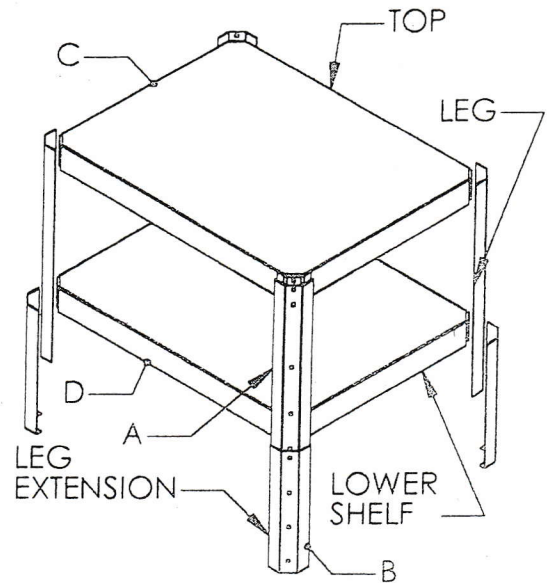

PART LIST

A	4 LEGS
B	4 LEG EXTENSION
C	1 TOP
D	1 LOWER SHELF
E	4 SWIVEL CASTERS W/BRAKES (3" HIGH)
*	40 1/4-20 X 5/8 BOLTS/NUTS

MODEL FOR MOBILE TABLE

WTM 182418	WTM 243618
WTM 182430	WTM 243630
WTM 243018	WTM 244818
WTM 243030	WTM 244830

HOW TO ASSEMBLE MOBILE TABLE

- Step 1
Attach 4 Legs to Steel Top. Use (2) ea. 1/4-20 x 5/8 Bolts & Nuts in each corner. (See detail A)
- Step 2
Attach 4 legs to Lower Shelf. Use (2) 1/4-20 Bolts in each corner.
- Step 3
Attach Leg Extensions to each leg under bottom tray and setting position at desired table height Use 2 bolts for each leg extension for maximum strenght.
- Step 4
Attach (4) swivel casters to lower shelf with (16) bolts and nuts.

