

Wall Hugging
Adjustable BED BASE
#WN7029 OKIN Motor

- 3 Individual Motors for Head-Tilt, Back Incline & foot Incline
- Wall Hugger / Dual Massage / USB Ports / Bluetooth / UnderBed Lighting
- Free APP for Bluetooth Smart Device Controlling (IOS & Android)

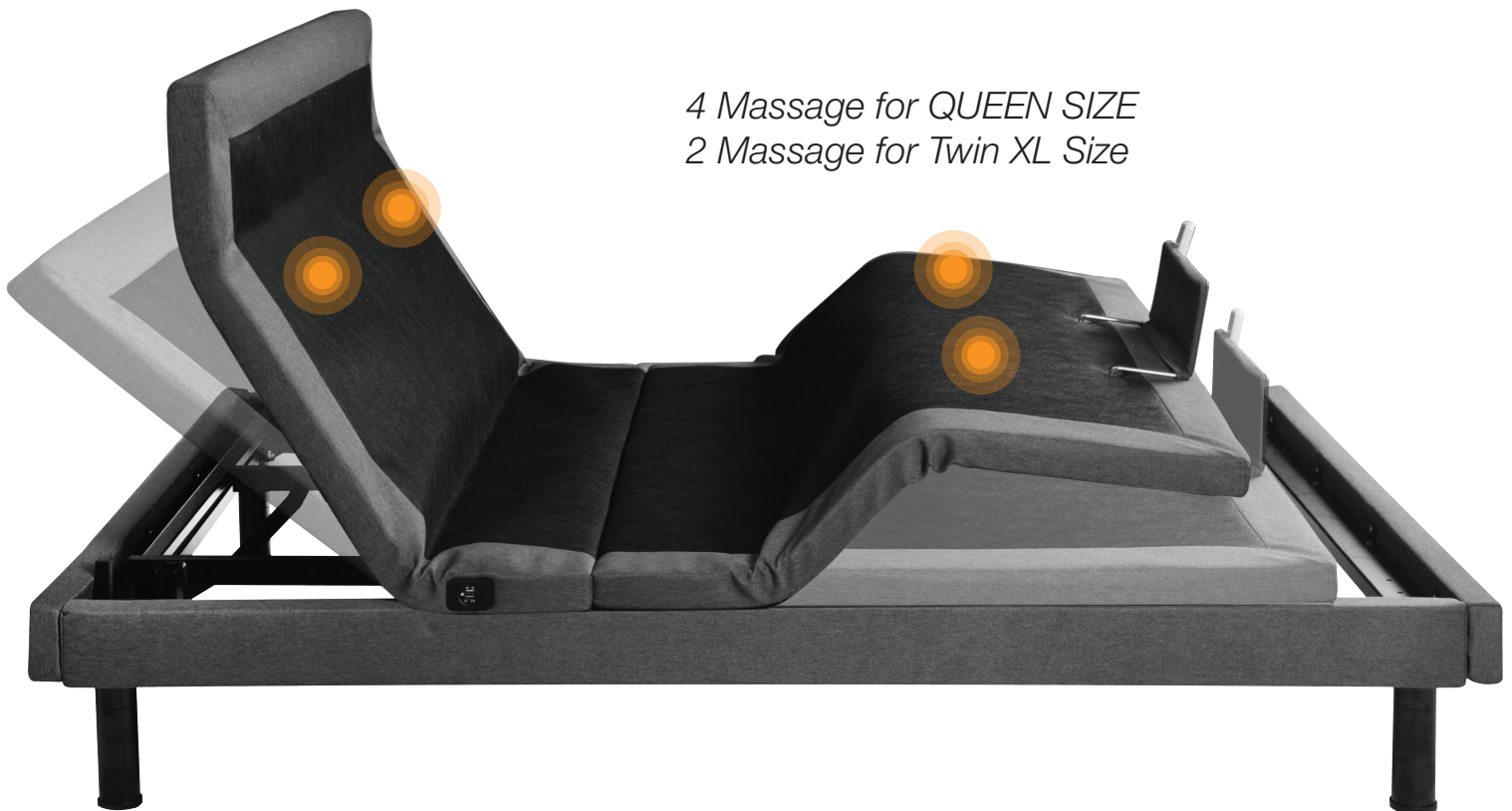

*4 Massage for QUEEN SIZE
2 Massage for Twin XL Size*

Owner's Manual

CONTENTS

Advisory
Setup and Installation
Wireless Hand Control

ADVISORY

Attention: Read the following information before using this product . Failure to use a surge protection device could compromise safety or cause product malfunction could void the electrical portion of your warranty.

- Electrical surges are by far the biggest cause of problems with electrical circuits. In order to help protect your investment in case of a power surge or outage, use an electrical surge protection device (not included).

WARRANTY WARNING!

Do not open or tamper with the transformer, control box, motors, or remote control (with the exception of battery compartments). The product warranty will be void if these components are tampered with.

SMALL CHILDREN AND PETS:

Immediately dispose of all packing materials as it can smother small children and pets. Do not allow any person or pets under the bed. Children, convalescents and disabled person should not operate the bed without adult supervision.

HOSPITAL OR CONVALESCENT USE DISCLAIMER:

Adjustable beds are designed and engineered for a life style of in-home comfort and are not intended for hospital use or for a bed-ridden patient on an extended recovery. Adjustable beds are not equipped with bars to help patients get safely in and out of bed and are not intended to be used around tent type oxygen therapy or explosive gases.

PACEMAKER WARNING:

The massagers in this bed produce mechanical vibrations that may activate a special sensor in your pacemaker that detects motion. This can fool the pacemaker into “thinking” you are engaged in some sort of physical activity and require a faster heart rate and you may experience a sensation similar to when you are exercising. Consult your physician for further information.

PRODUCT RATINGS:

PRODUCT RATINGS: The product’s lift motors are not designed for continuous use of more than 2 minutes in an 18 minute period, or approximately 10% duty cycle. For every 30 minutes the massage motor is used, the massage motor needs 30 minutes of rest. The massage function should be used for a maximum of 2 hours in a 12 hour period. Any attempt to circumvent or exceed this rating will shorten the life expectancy of the product and may void the warranty.

WEIGHT UNITS:

The limitation for this adjustable bed is 750 lbs. The bed will structurally support these weights, provided it is evenly distributed across the head and foot sections. This product is not designed to support or lift this amount in the head or foot section alone. Exceeding this weight restriction could damage the bed and/or cause injury and void the warranty. Enter or exit the bed in a flat position and do not sit on the head or foot sections while in the raised position.

LIFTING AND LOWERING MECHANISMS AND MASSAGE UNITS:

It is normal for the raising and lowering feature on this bed will emit a minimal humming sound during operation. The massage feature creates a vibrating hum during operation and the resonance will increase accordingly with a higher intensity motor setting.

LOCATION ENVIRONMENT:

The level of sound experienced in a room is directly related to the environment within that location. In a room with hardwood floors and the massagers turned on, a vibrating noise can be noticeable. To reduce the resonance, place a piece of carpet or rubber casters cups under the legs. The rubber caster cups also prevent the bed sliding when located on smooth or hard surface flooring.

TO REDUCE THE RISK OF SHOCK, BURNS, FIRE OR INJURY:

Make sure the base is in a flat position, the vibrating motors are off before unplug from power source. Always unplug the base from the electrical outlet before cleaning or servicing the base. If the cord or plug is damaged, discontinue use of the bed base and contact qualified service personnel for examination and repair.

FCC COMPLIANCE:

This device complies with part 15 of the FCC Rules for residential use.

Operation is subject to the following two conditions:

- (1) This device may not cause harmful interference, and
- (2) this device must accept any interference received, including interference that may cause undesired operation.

Radio Frequency: 2.4 GHz

EMERGENCY BATTERY BACKUP:

In the event that the base is stuck in an articulated position during a power outage-the battery backup in the transformer will return the base to flat position. Batteries are not to be used for normal operation of the base. Install two 9 volt alkaline batteries into the battery backing transformer. Use the reset button on the control box or the extension cord from the control box to the transformer to return the base to a flat position.



GERMAN
Technology

2 x 9V alkaline batteries



Batteries Not Included



PAIR button









SETUP & INSTALLATION

**Important: We strongly recommend
Two able-bodied adults setup and
assemble this product.**

Step 1:

Check and verify all parts are included before discarding any packing materials.

All electronics and components that need to be installed are located in boxes under the base or attached to the frame.

A) Wireless Remote Control (1)	A) 	B) 	C) 	D) 
B) Mattress Retainer Bar (1)	E) 	F) 	G) 	H) 
C) Legs 4" +6"(6)	H) SYNC Cord (1) (only for TXL bed)			

I) Rail: Right, Left, Head, Foot

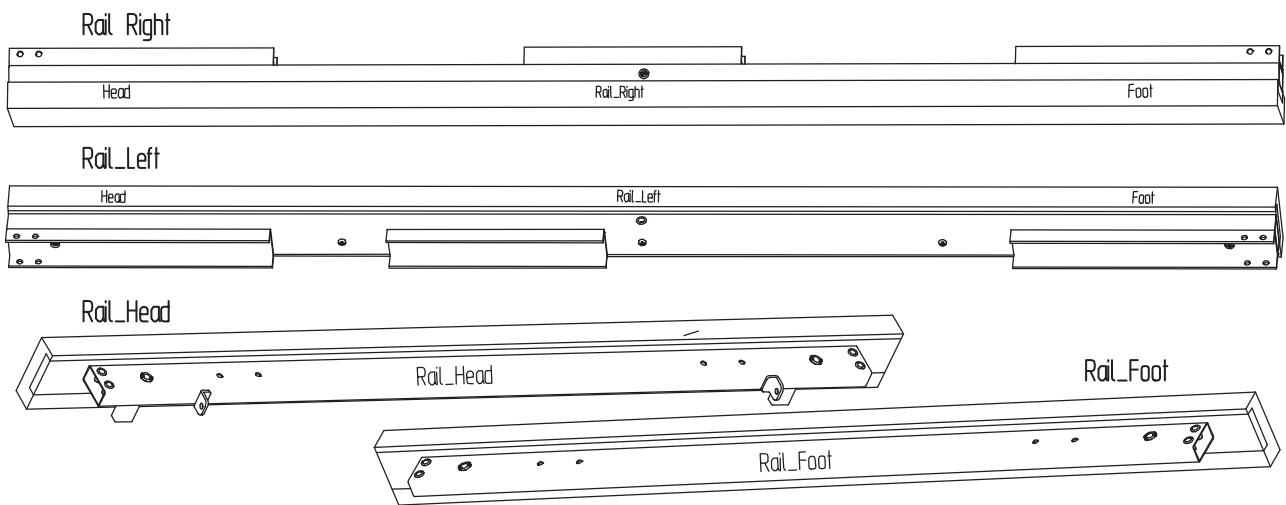

J) Connecting Rod



K) Pull Rod x 2pcs

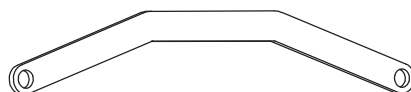

- L) Bolt_M8*20 10pcs Nut_M8 4pcs Bolt 4pcs Spring Washer 4pcs Plastic Washer 4pcs Steel Washer_D10 4pcs



Allen Wrench_S6

Wrench_S13

Wrench_S17

Plastic Washer_D10 4pcs



Step 2:

With the help of your able-bodied assistant, place carton on floor with arrows point downwards.

Step 3: Install diagram, Overview

Please follow **Step 3-1** to **Step 3-5**, do not disturb the Steps.

Overview

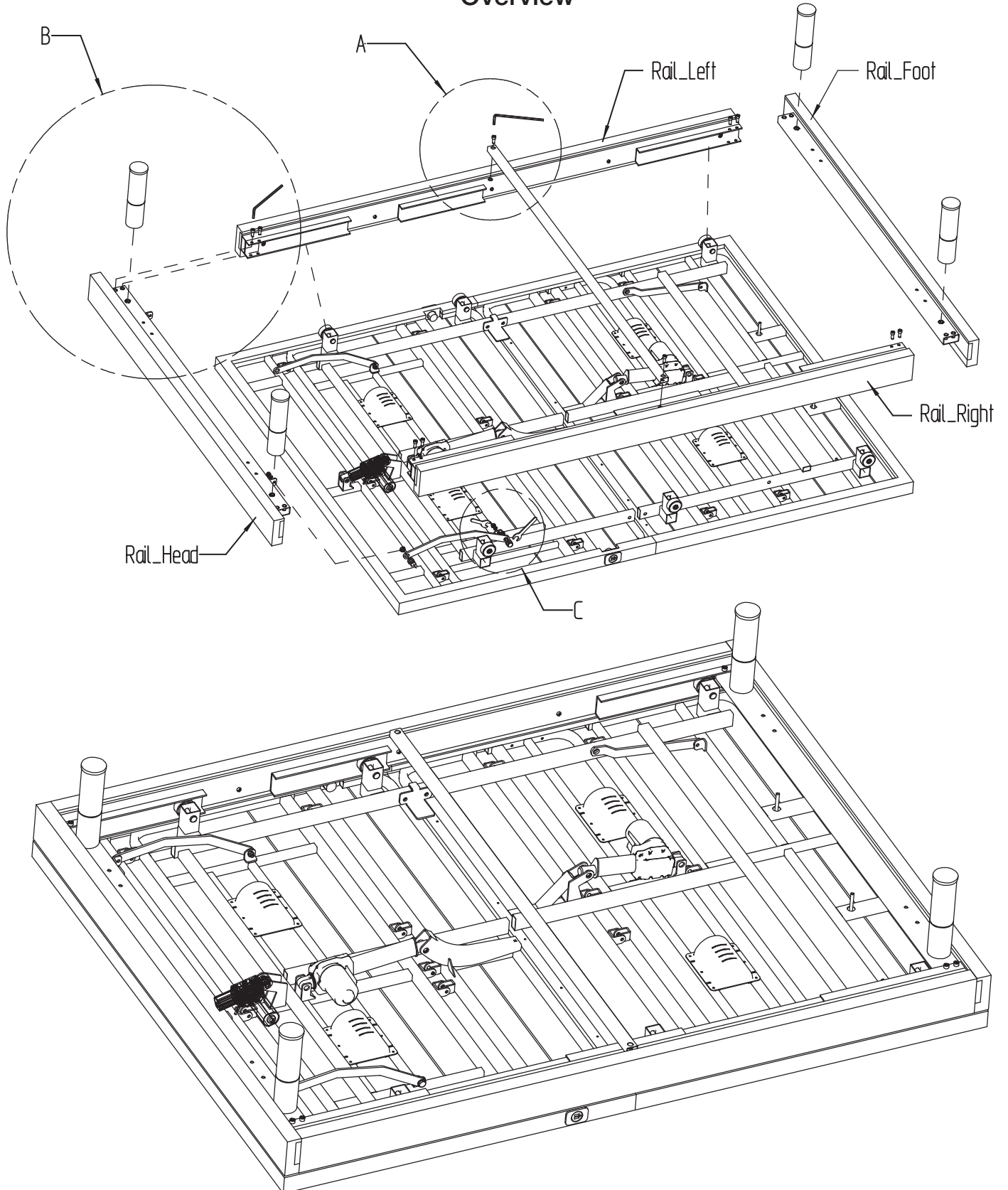

Step 3-1

Open the Outer Cartons and Place the **Rail_Right** & **Rail_Left** to the right side like below

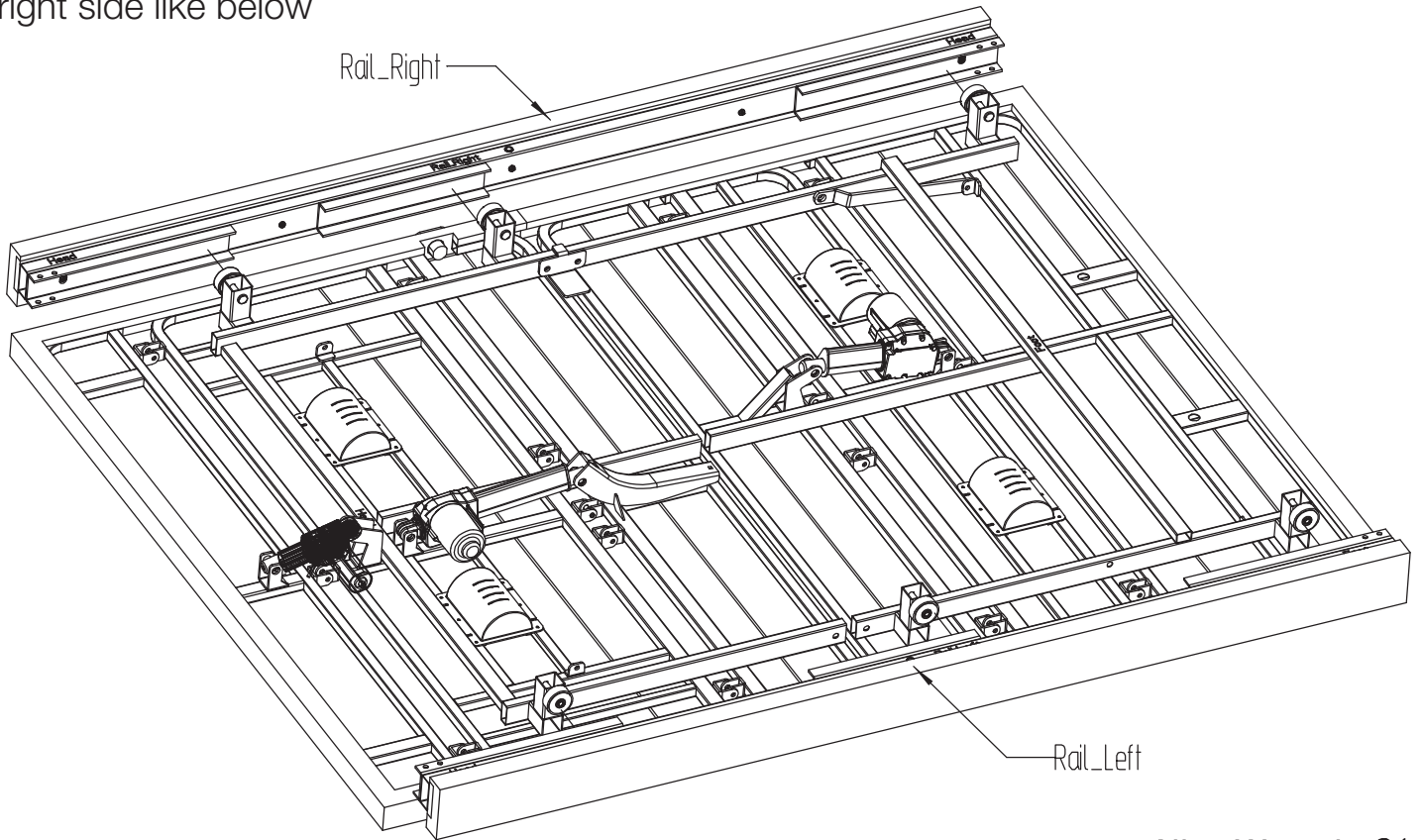

Step 3-2

Install the **Connecting Rod**.

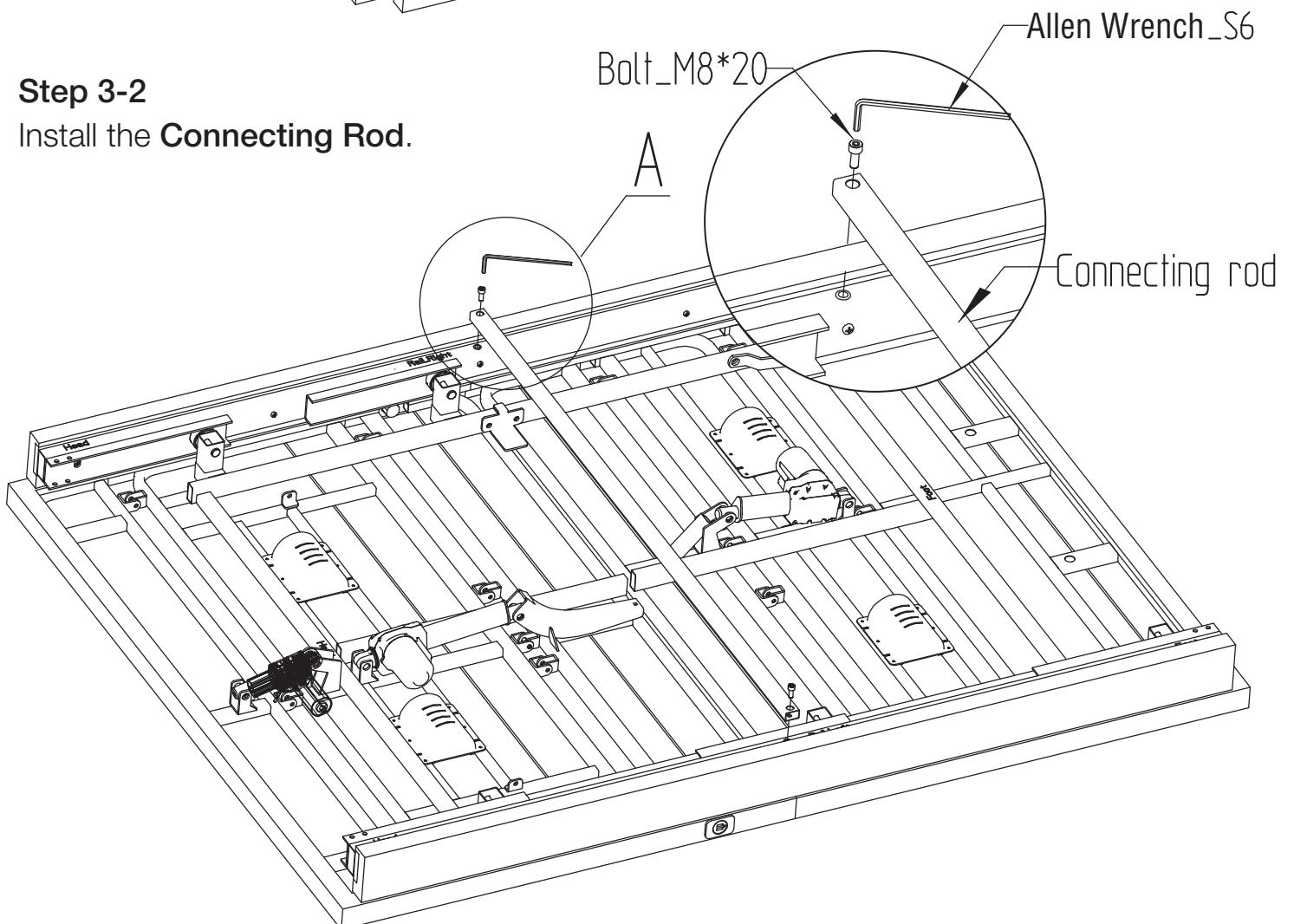

Step 3-3

Install the **Rail_Head & Rail_Foot**.

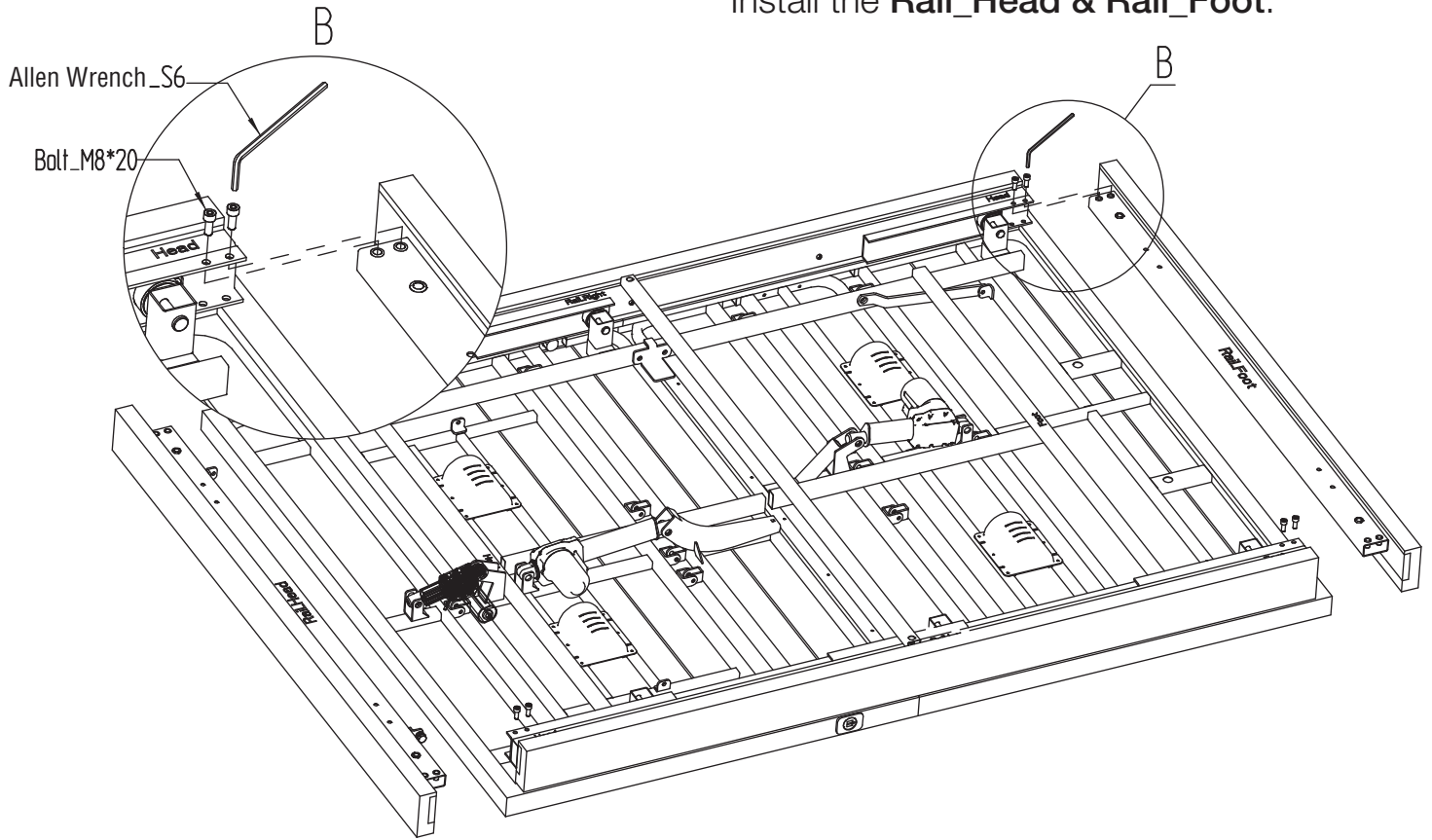

Step 3-4

Install **Pull_Rod**

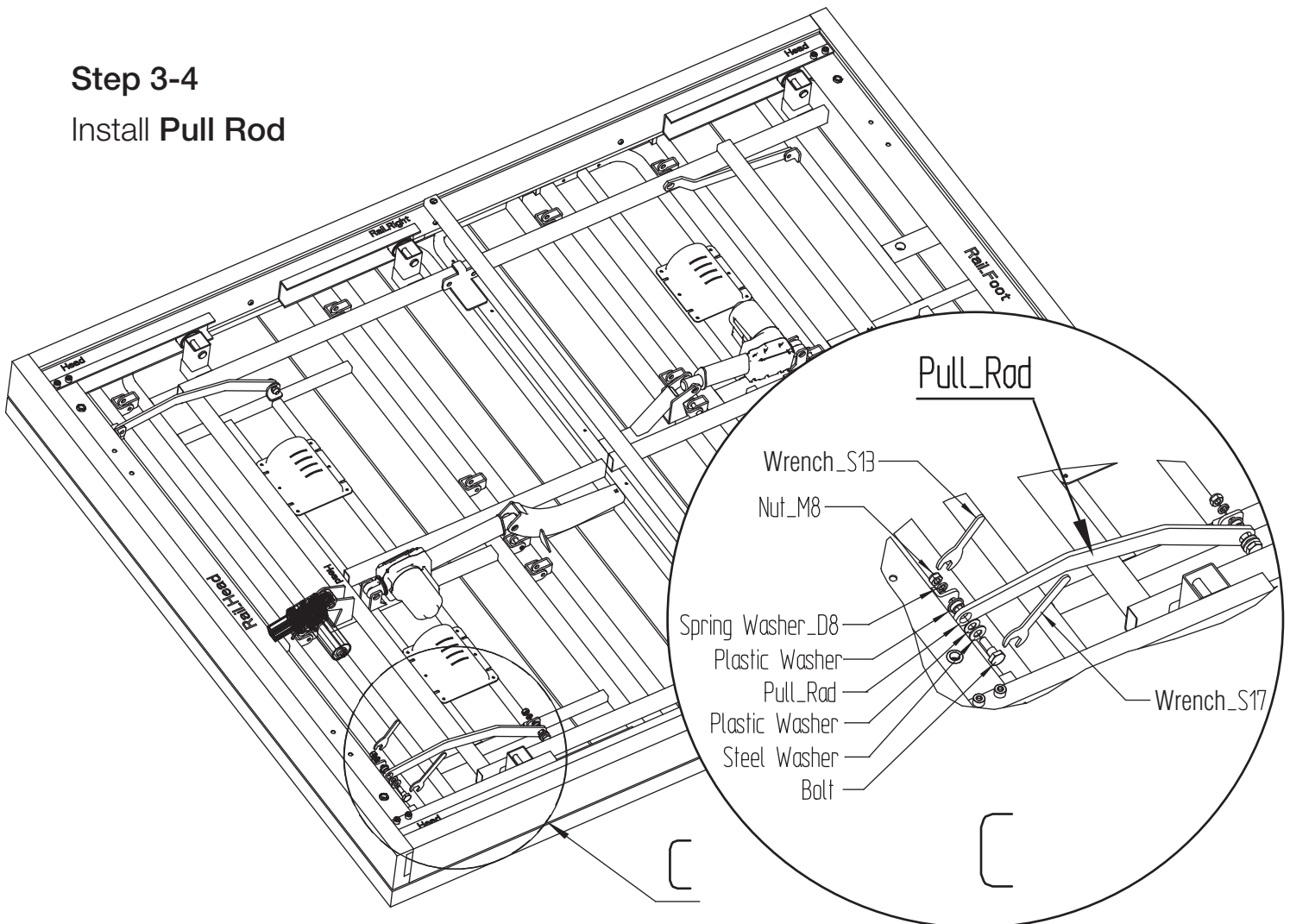

Step 3-5

- Install the four legs firmly into the base of the frame.
The four legs screw into the threaded holes in each corner of the adjustable base frame.
The legs are stackable. The combination give you a set of six 4", 6" or 10" legs.
- Note: The minimum leg height:4", The warranty is void if the minimum leg height is not used.
- Do not over tighten.

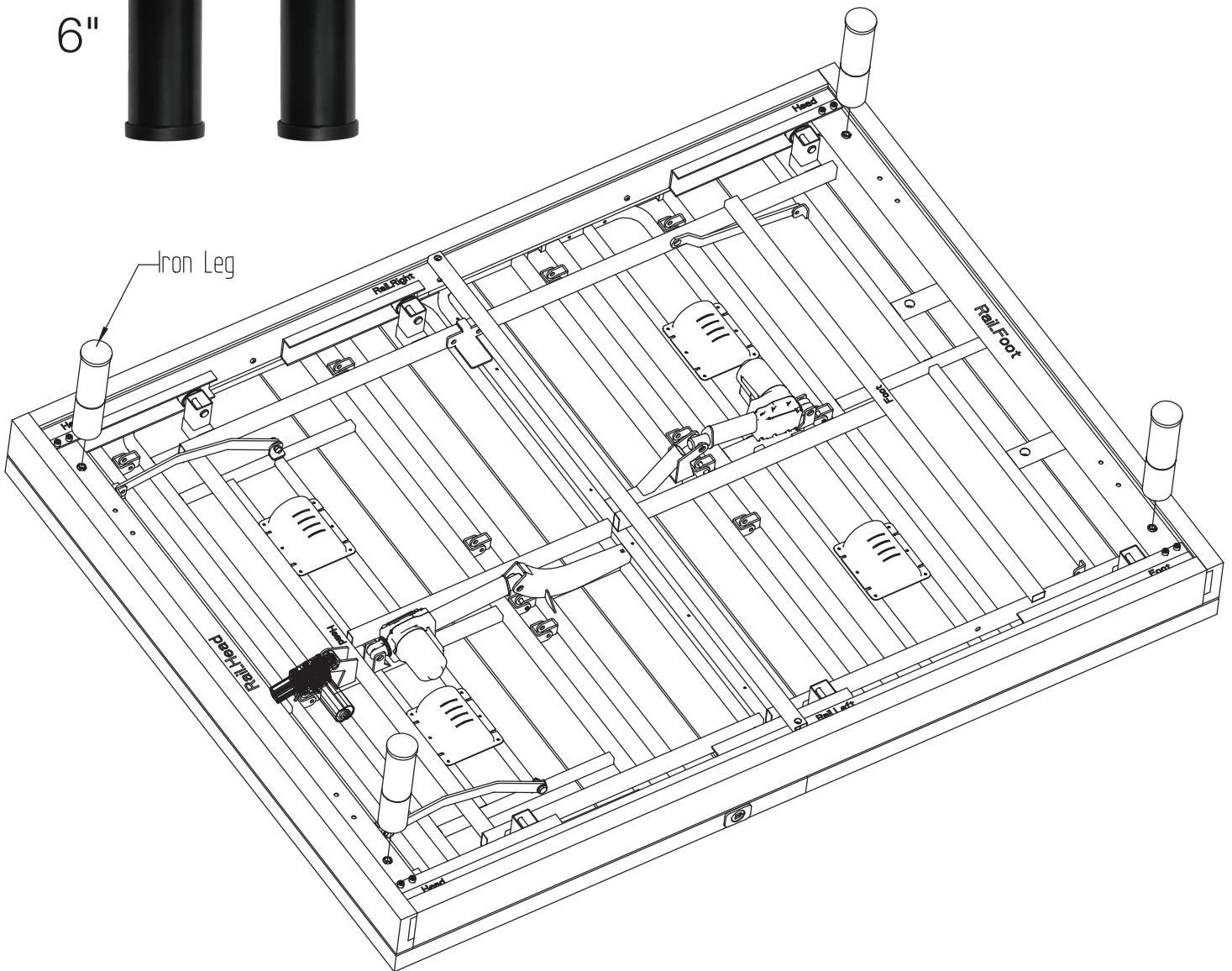
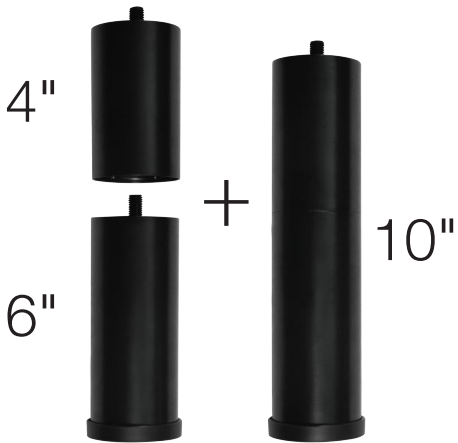

Step 4:

Connect the Transformer “E” to Control Box “F” with Cord “G” : The Control Box is the Black Box attached to the bottom of the bed . Plug one side of Power Cord DC “G” into the Control Box “F” and Plug another side of “G” into Transformer “E” .
Extend the Power Cord AC “D” and plug it into the Transformer “E” .
Connect the Plug to 110V Power socket.

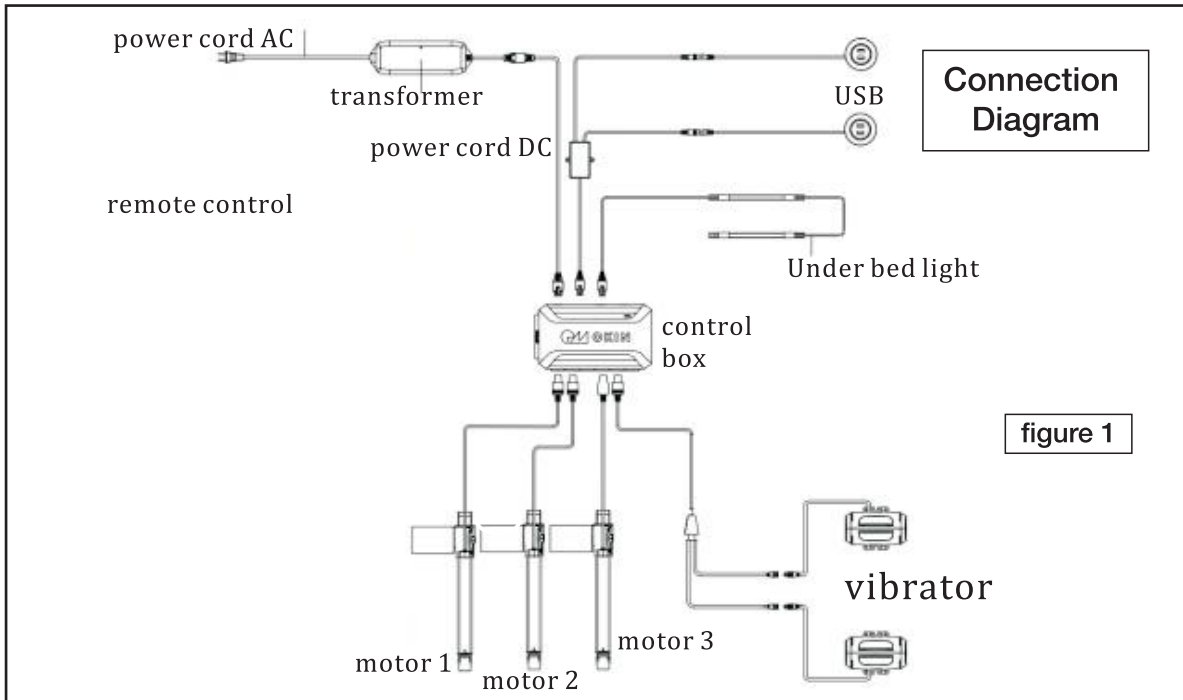

Step 5:

With the help of your able-bodied assistant , carefully lift the adjustable bed frame and set it in place upright on its legs . Excessive pressure may damage the legs. Remove all protective plastic covering. Note: check and make sure that all power cords clear and do not interfere with any Adjustable Bed Mechanisms;
Dispose of covering property to avoid injury.

Step 6:

Note: The Mattress Retaining Bar is tied to the underside of the base for shipping. Install the Mattress Retaining Bar upright by carefully aligning and pushing the bar into place. Insert the Mattress Retaining Bar into the holders at the foot of the bed.(Figure 3,4)
The Mattress Retaining Bar prevents the mattress from slipping off the base and should not be used as a handle of the base. Using as a handle will damage the retaining bar holders. Screws come out from the retainer bar holders will be considered as a damaged part and not a defective part and is not covered by the warranty.

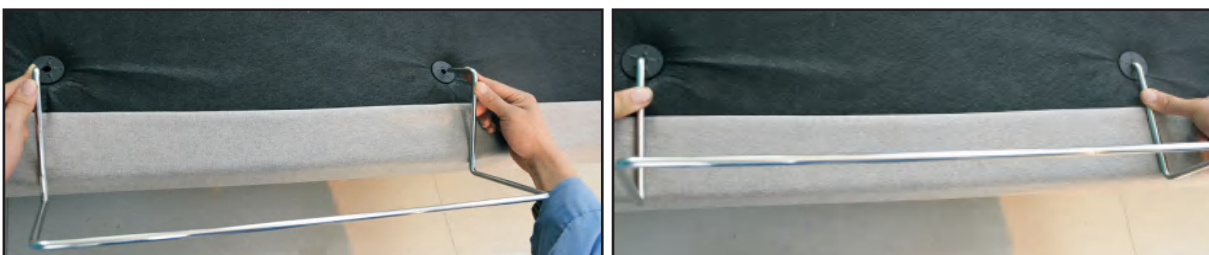

figure 3 & 4

Step 7:

Scan QR Code to download Free Bluetooth APP "OKIN ComfortBed II".
(IOS & Android)



(Android)



(IOS version 8.0 and above)



How to pair the bed to APP:

Please open BLUETOOTH on your phone settings,
then open the "OKIN ComfortBed II" app and follow below steps:

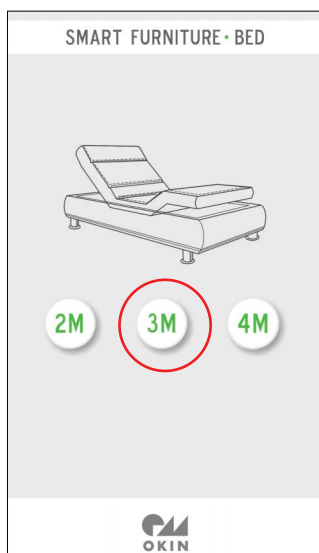

Step1:
CHOOSE
"3M"

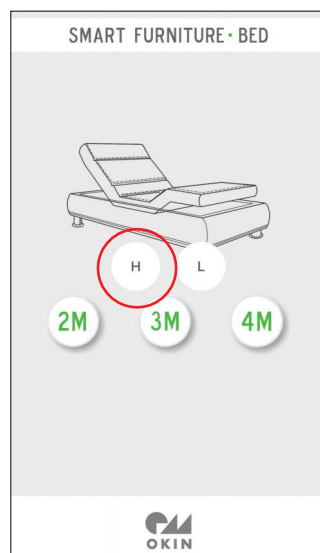

Step2:
TOUCH
"H"



Step3:
Click
"Setting"

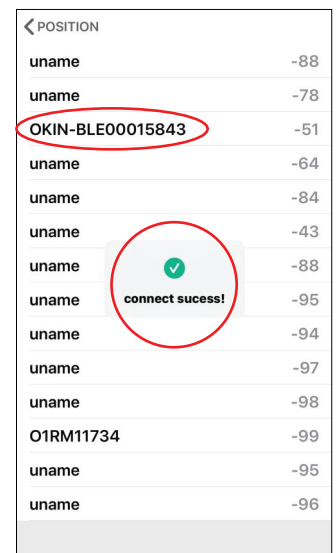

Step4:
Select the device named
"OKIN-xxxxxxx"
the APP will be connected and says
"connect success!"

APP Functions

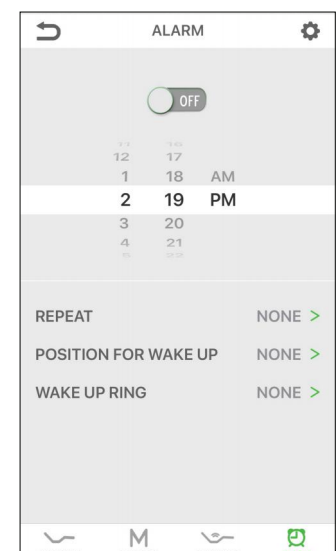
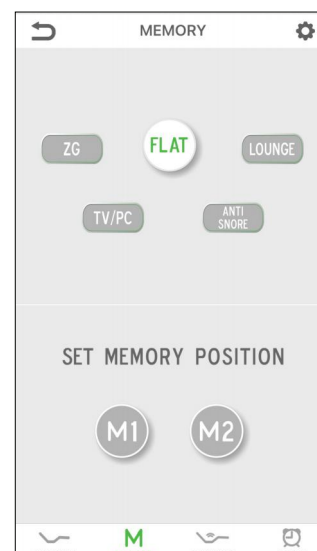
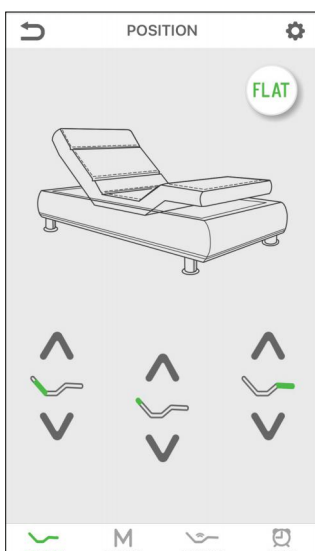

***** **ATTENTION** *****

The remote control has already been synchronized and preset during production. Please skip Step 8 unless the remote does not work.

Step 8:
Synchronize the remote with the control box.

First find the black box mounted under the bed. Double-click the black **PAIR button**, the **Indicator Light** of the control box change to blue and the under bed light flashes, At this time, it enters the pairing state. Then press the **PAIR button** on remote control , the back light of the remote control flashes, At this time, the remote enters the pairing state. until the back Light on remote control stop flashing and constant, the **Indicator Light** of the control box changes from blue to green and constant or the under bed light stop flashing and turn off (See Figure 5).

The adjustable bed should be working after matching the remote with the control box. Press the Head Up button , Foot Up button , and Flat Button to test.

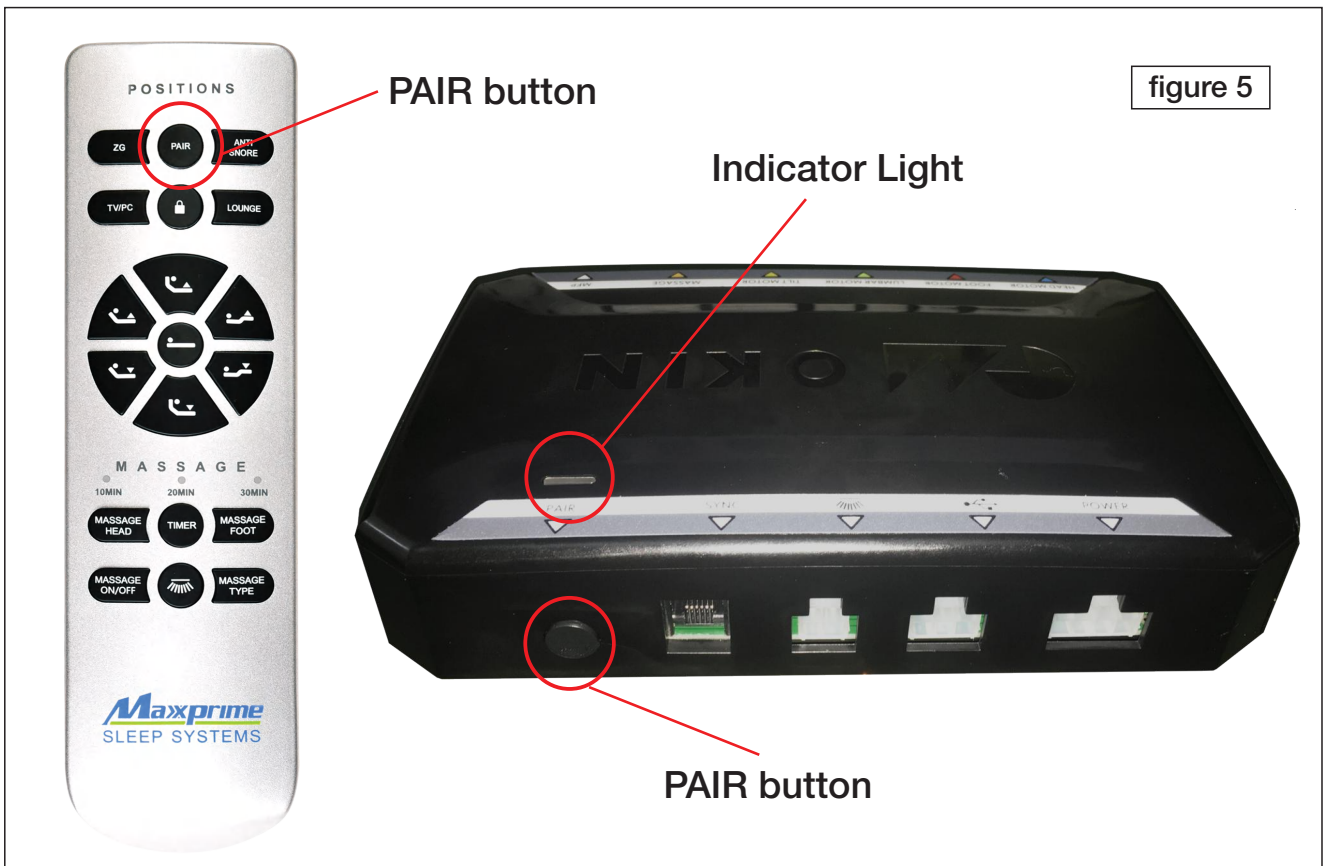

USING SAME REMOTE

The bed base is designed to allow two Twin X-Long bases to become an Split-King base. Owner can use the same remote to control two side-by-side beds bases by Connecting the two control boxes with the SYNC cord (H). Plug one side of the cable into the “SYNC” on the side of the control box and plug another side into the “SYNC” on the side of another control box , then you can connect two control boxes(See figure 6&7) .

It is important that the two control boxes expected to work synchronously must be still configured differently to pair with the different remote control with different DIP-Switch position. Do not pair both control boxes with the same remote control , Each remote must have a different DIP-switch setting.

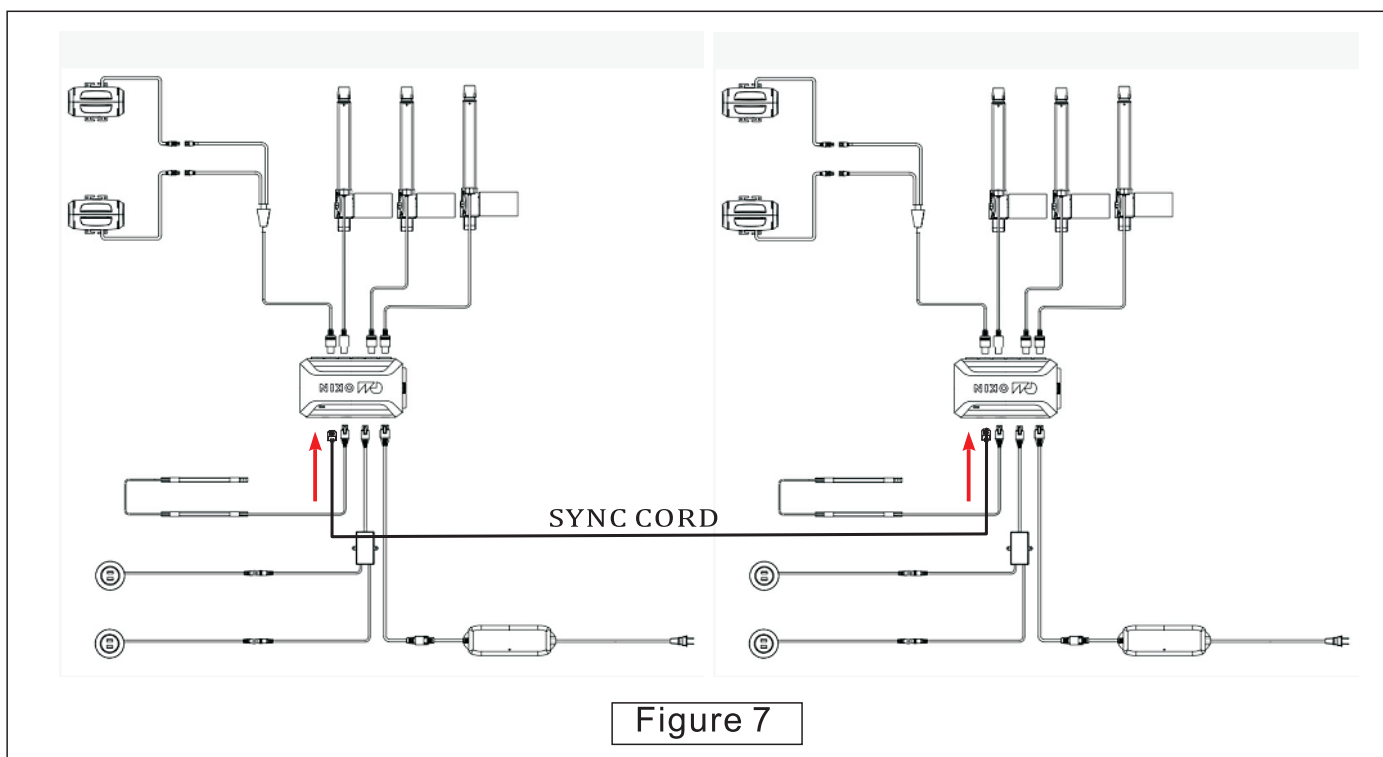
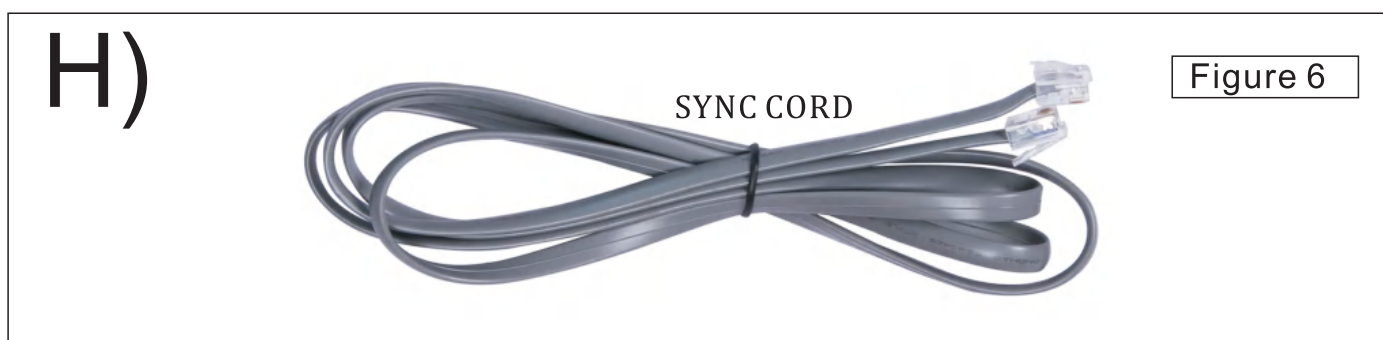

The synchronise cord is not on the full warranty list. We will replace it for free if it is defective.

Setup is now complete. Enjoy.

Wireless Remote

#WN7029 Wall Hugging Adjustable Bed Base with OKIN Motor

Memory Button ZG, ANTI- SNORE, TV, LOUNGE.
Press once to raise to Preset position.

● **Preset Position Button ZG, ANTI- SNORE, TV, LOUNGE.**

1. Press the "FLAT" button to return the bed to flat position .
2. Adjust the head and foot to desired positions .
3. Press and continue holding in the 'ZG' 、 button for around 5 seconds until until timer LED flashes confirm the successful setting.
4. You can reset the 4 position button by repeating the above steps .

● **PAIR Button**

Use to Synchronize the remote control with the control box.

● **Head Up Button**

Used to raise the head of the bed base

● **Head Down Button**

Used to lower the head of the bed base

● **Pillow Tilt Raise/Down Buttons**

Use to raise or lower the Pillow tilt of the bed

● **Head Massage Button**

- Turn the head massage on and off.
- Adjust massage intensity for the head.

● **Massage ON/OFF**

Use to turn ON/OFF HEAD/FOOT massage

● **Timer Button**

- Use to set the desired time,
Select 10-20-30 MIN first and then turn the HEAD/FOOT massage button on.

Children Safety Lock and Unlock Buttons

Press and hold child lock button, the red backlight of this button flashes, after press for 5s, the red backlight stop flashing, the remote enters locking mode. Press the child lock button for 5s, the red backlight flashing until off, remote enters unlocking mode.

Foot Up Button

Used to raise the foot of the bed base

Flat Button

Press to return to flat position

Foot Down Button

Used to lower the foot of the bed base

Foot Massage Button

- Turn the foot massage on/off.
- Adjust massage intensity for the foot.

Massage Type Button

Offer 3 massage actions:
Pulse, Wave & Constant

Under Light Button

Use to turn on and off the under light

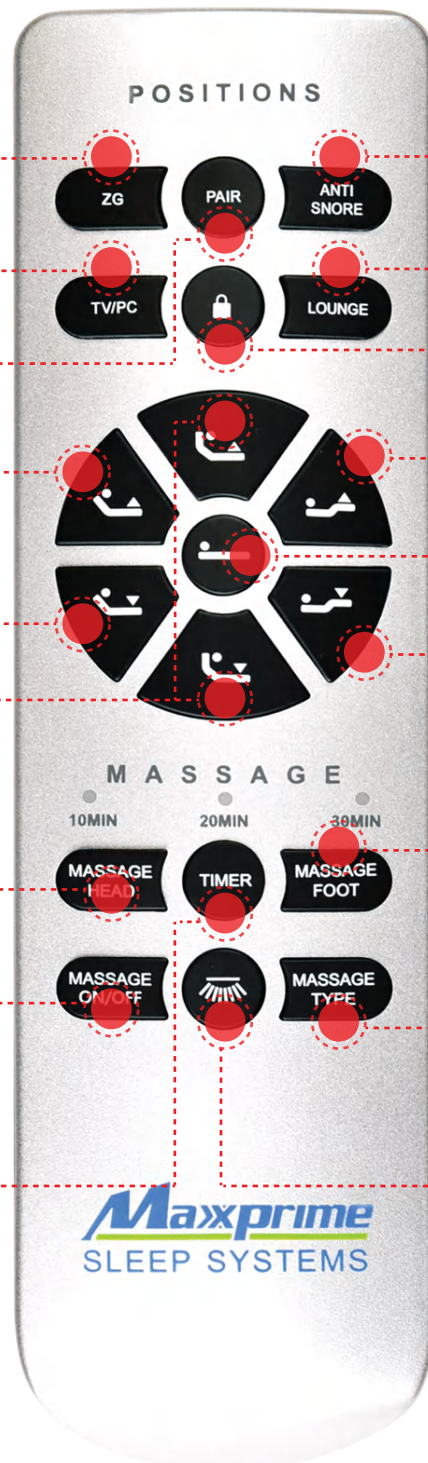

GERMAN
Technology



0-30 DEGREES
Individual Head/Pillow Tilt

0-60 DEGREES
Individual Back Incline

0-45 DEGREES
Individual Foot Incline



Wall Hugger Technology

WallHugger Technology to
keep you within reach of
your night stand/side table
up to 9inch / 23cm

WHEN TWO BEDS DO NOT ALIGN:

on the higher angled bed of the two, use a 19mm wrench to turn the nuts on the new "LEVEL RIGHT" counterclockwise to adjust the angle until the higher angle bed match the level of the lower angle bed and lock the nut with the reinforce nuts. The two beds are now aligned. (For Twin XL and SPLIT CK)



Dear Valued Customer,

Thank you so much for your order, we sincerely hope that you would be satisfied with our product and service.

Your satisfaction will be a great motivation for us. We would do our best to offer you a pleasure shopping experience on Amazon, if you have any concern about our product and service, please do not hesitate to contact us via support@maxxprime.com



We are looking forward to hearing from you in the near future and also we expect have a long term corporation with you.

Yours sincerely,
Thank you,

Maxxprime Customer Support
E-mail: support@maxxprime.com