

NOTICE

- * Please make sure that you have all parts indicated and they are in good condition before you begin assembly of this item. Refer to part list and hardware list below for guidance.
- * This item should be assembled on a soft surface to prevent scratching the finish during assembly.
- * This item may require periodic tightening.

PREPARATION

- * Before beginning assembly of product, make sure all parts are present. Compare parts with part contents list and hardware contents list.
- * If any part is missing or damaged, do not attempt to assemble the product.
- * Estimated Assembly Time: 10 minutes.
- * Tools required for assembly: Allen Key (included)

CARE AND MAINTENANCE

Always use felt pads under all articles to prevent discoloration or softening of the lacquer. Plastic and rubber bases on items can discolor wood. Wipe up spills immediately and avoid common hazards such as hot dishes, harsh solvents, and abrasives. Cleaning should be done with a soft lint free cotton cloth dampened with water.

Model #: SFV7231A

Product Dimensions: 94.0"D x 39.0"W x 29.5"H

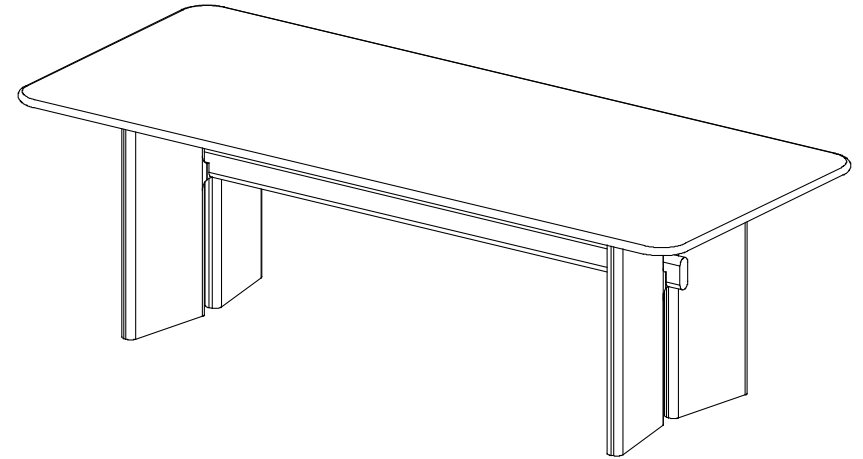

Part List and Hardware List

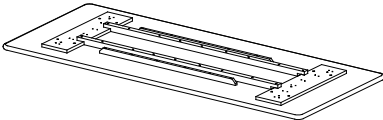
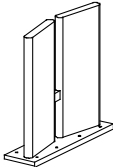
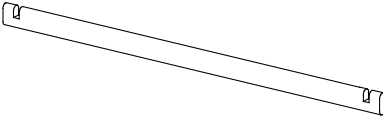
PIECE	DESCRIPTION	PICTURE	QUANTITY	CARTON CALL
A	Table top		1X	1 of 2
B	Leg		2X	2 of 2
C	Strecher		1X	1 of 2

▲ WARNING ▲

Weight capacity - 280 LBS
 Warning: Do not stand on Table
 Warning: Do not over torque bolts

HW1	Bolt: M6x1x65 mm		2X	2 of 2
HW2	Bolt: M8x1.25x40 mm		20X	2 of 2
HW3	Split Lock Washer: M6x11mm		2X	2 of 2
HW4	Flat Washer: M6x18 mm		2X	2 of 2
HW5	Split Lock Washer: M8x14mm		20X	2 of 2
HW6	Flat Washer: M8x20 mm		20X	2 of 2
HW7	Allen key		1X	2 of 2

PREPARATION

- * Before beginning assembly of product, make sure all parts are present. Compare parts with part contents list and hardware contents list.
- * If any part is missing or damaged, do not attempt to assemble the product.
- * Estimated Assembly Time: 10 minutes.
- * Tools required for assembly: Allen Key (included)
- *

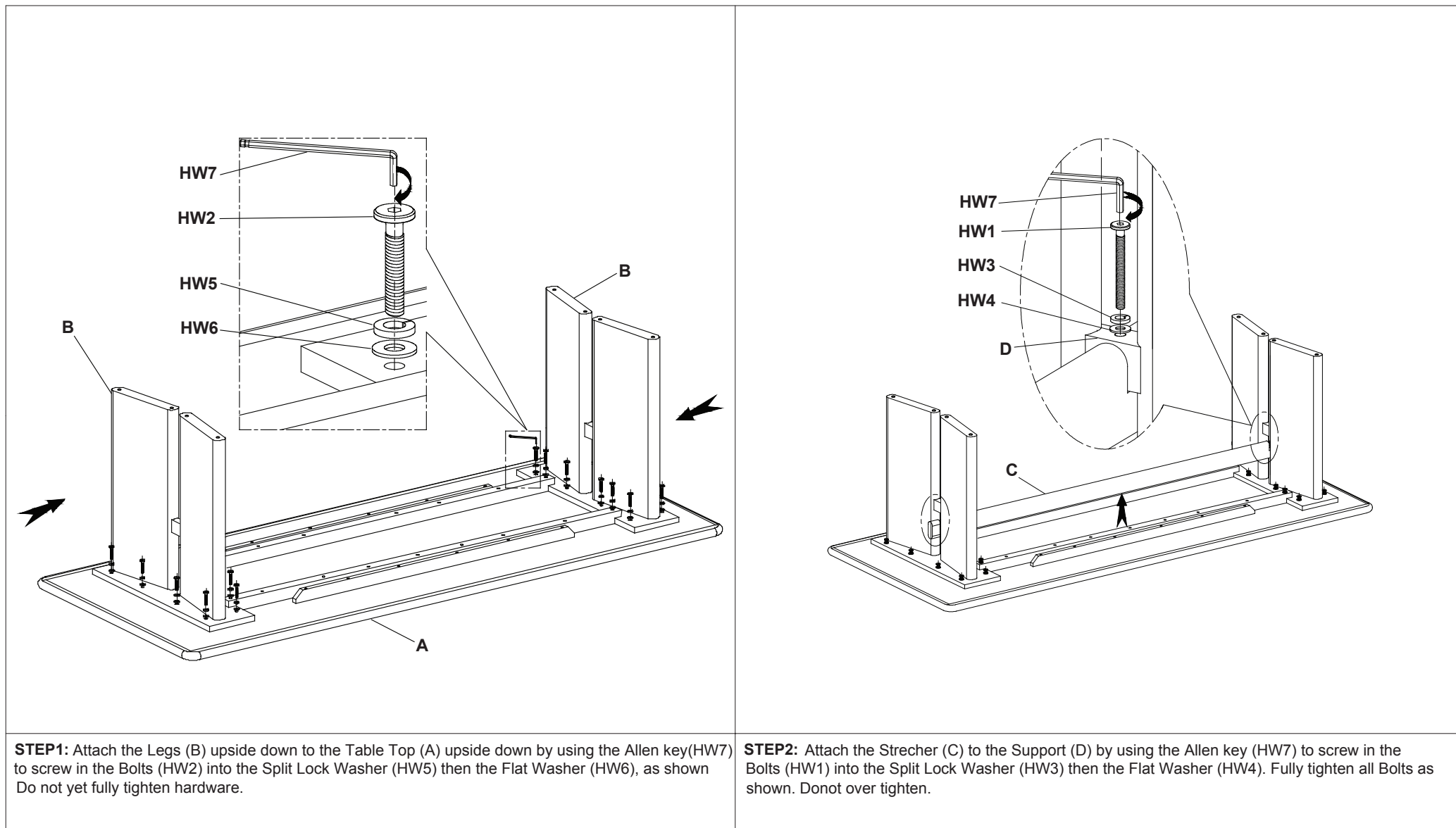

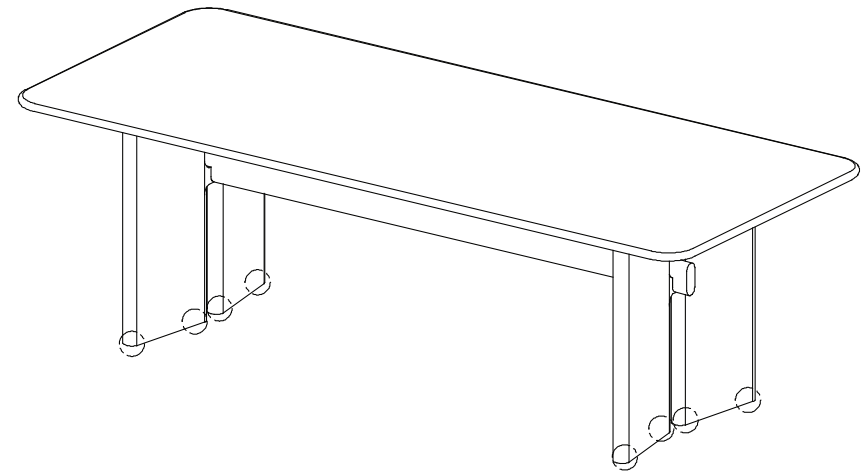
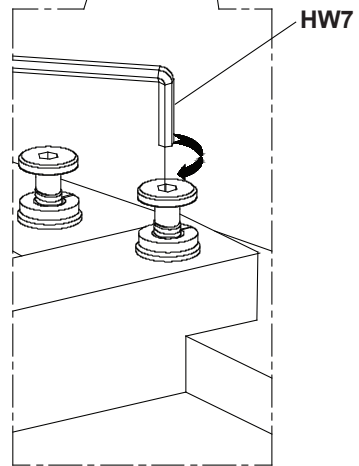
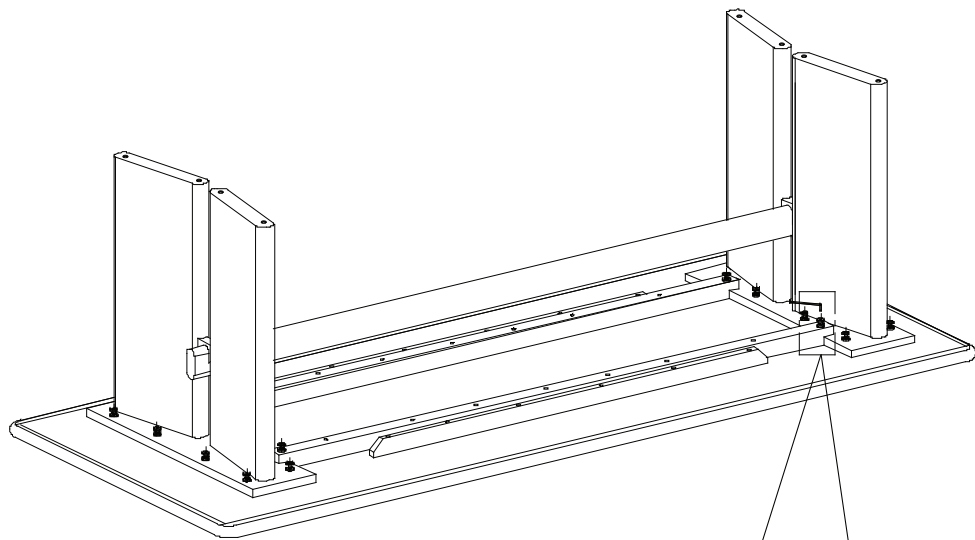

NOTE: Adjust levelers under foot if needed.

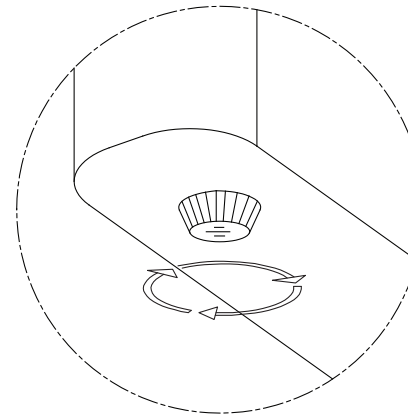

STEP3: Using the Allen Key (HW7) fully tighten all Bolts from previous. Do not over tighten.

STEP4: Assembly is now complete and the Product is ready for use.