

Assembly Instructions

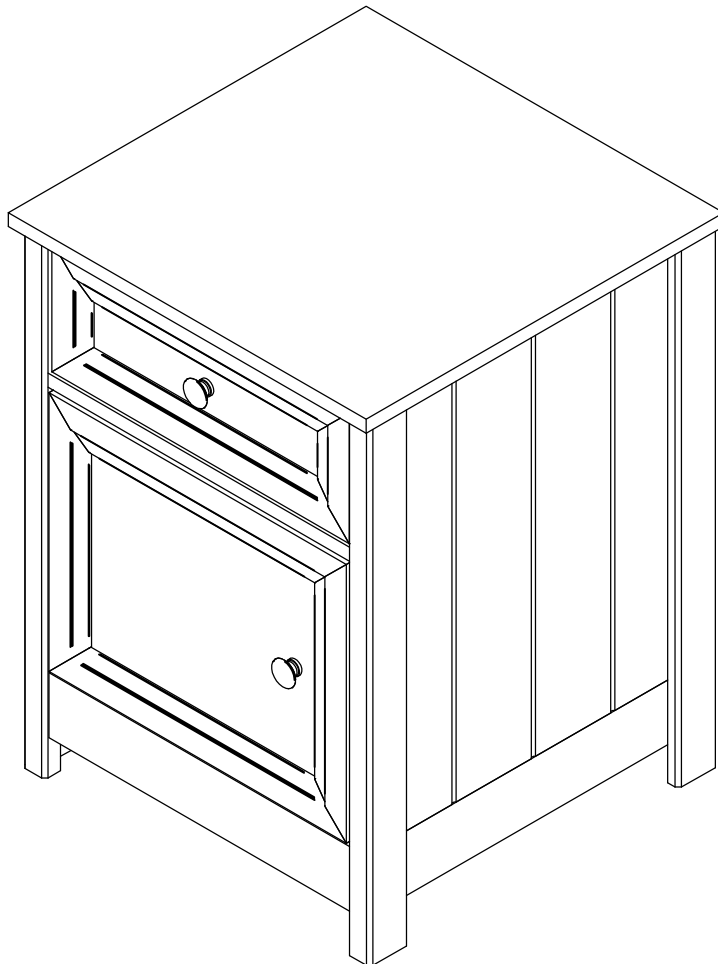

General Assembly Guidelines

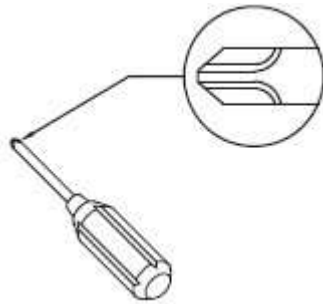



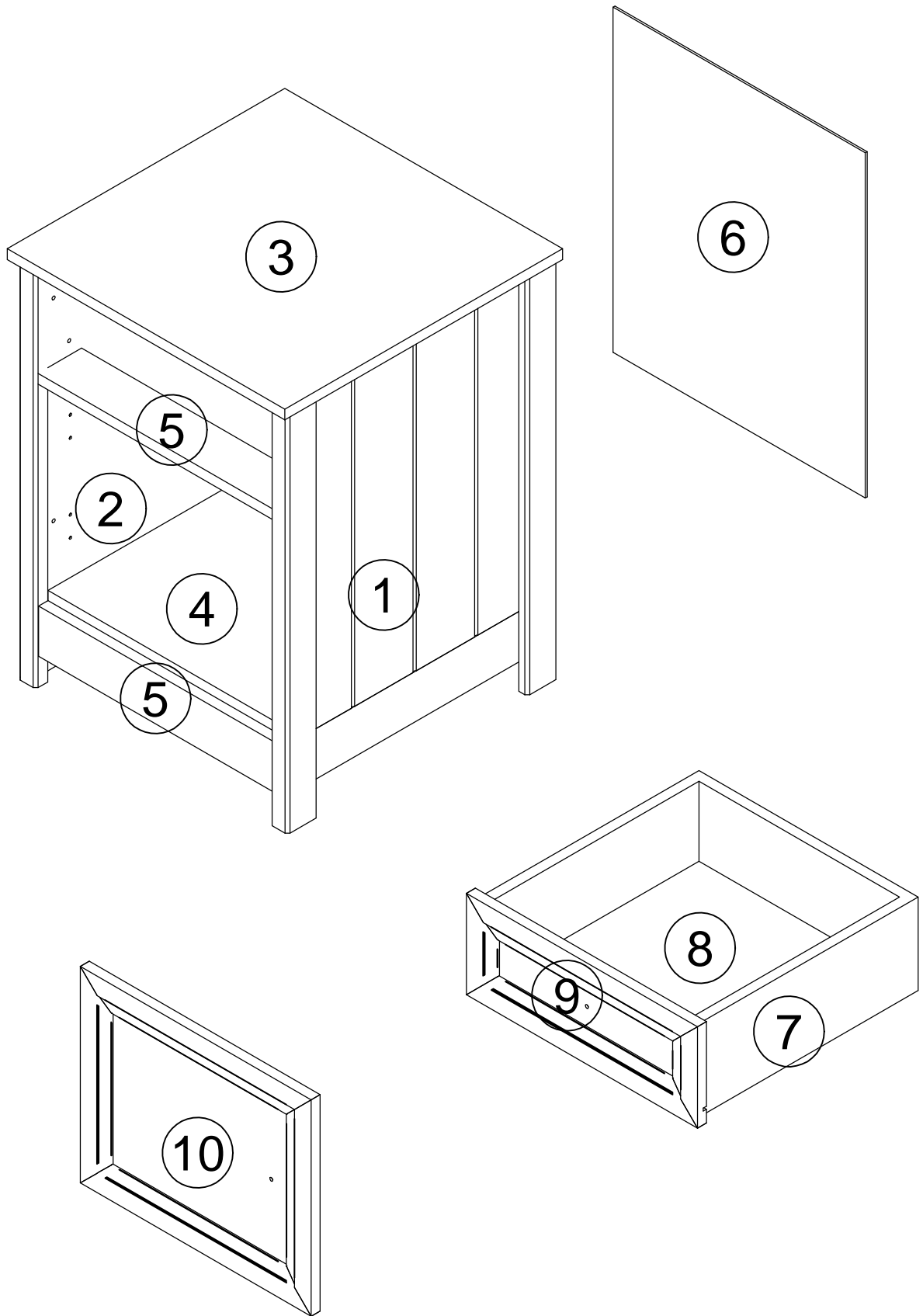

- I. Ensure that all parts and hardware are available before beginning assembly.
- II. Follow each step carefully to ensure the proper assembly of this product.
- III. Two people are recommended for ease in the assembly of this product.
- IV. The two main types of hardware used to assemble this product are: wood dowels and screws.
- V. A Phillips head screwdriver is required for the assembly of this product (not included)

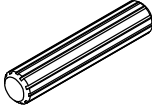

Parts List

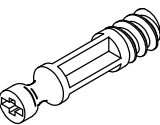
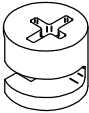
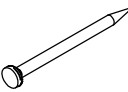
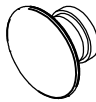
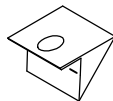

Hardware List

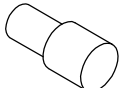
A		Ø 6x30mm	Wood Dowel	4pcs
B		Ø 5x14mm	Foot	4pcs
C		Ø 3,5x14mm	Screw	20pcs
D		Ø 6x10mm	Screw	4pcs
E		Ø M4x10mm	Screw	2pcs
F		Ø 6x35mm	Cam Bolt	16pcs
G		Ø 15mm	Cam Lock	16pcs
H		Ø 1,5x22mm	Nail	25pcs
I		Ø 30x20mm	Handle	2pcs
J		Ø 14x14mm	Back Support	4pcs
K			Hinge	2pcs
L		350mm	Slider	1pcs
M		Ø13x3,5mm	Silicone Backstop	1pcs
N		Ø6x8mm	Plastic Pin	1pcs

STEP 1. Secure cam bolts (F) into parts (1,2,3,9). Insert dowels (A) and plastic pin (N) into part (5).

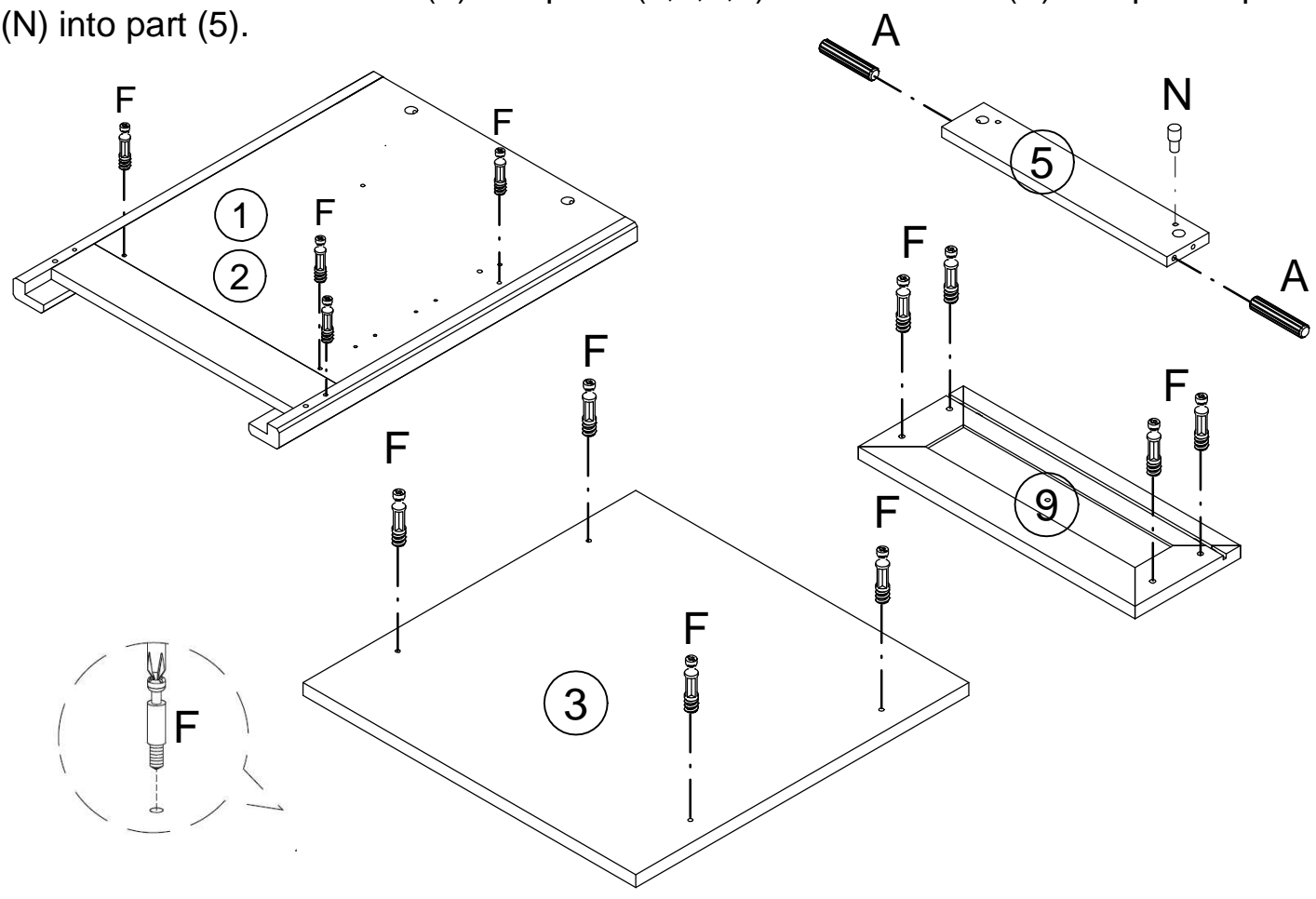

STEP 2. Attach sliders (L) to parts (1,2) using screw (D). Secure feet (B) to parts (1,2) using nail (H).

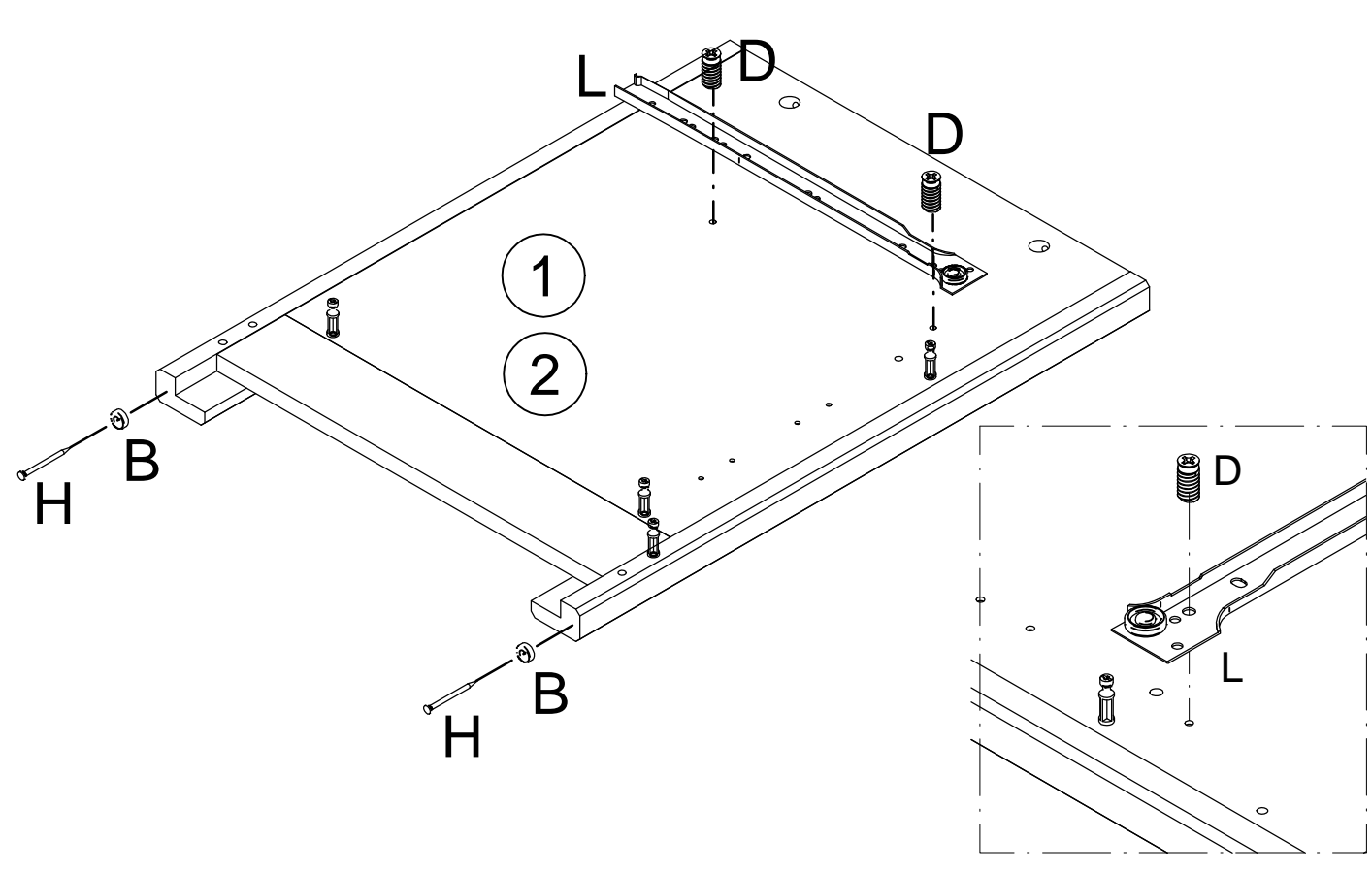

STEP 3. Insert panel (8) into drawer frame (7). Secure part (9) to part (7) using cam lock (G).

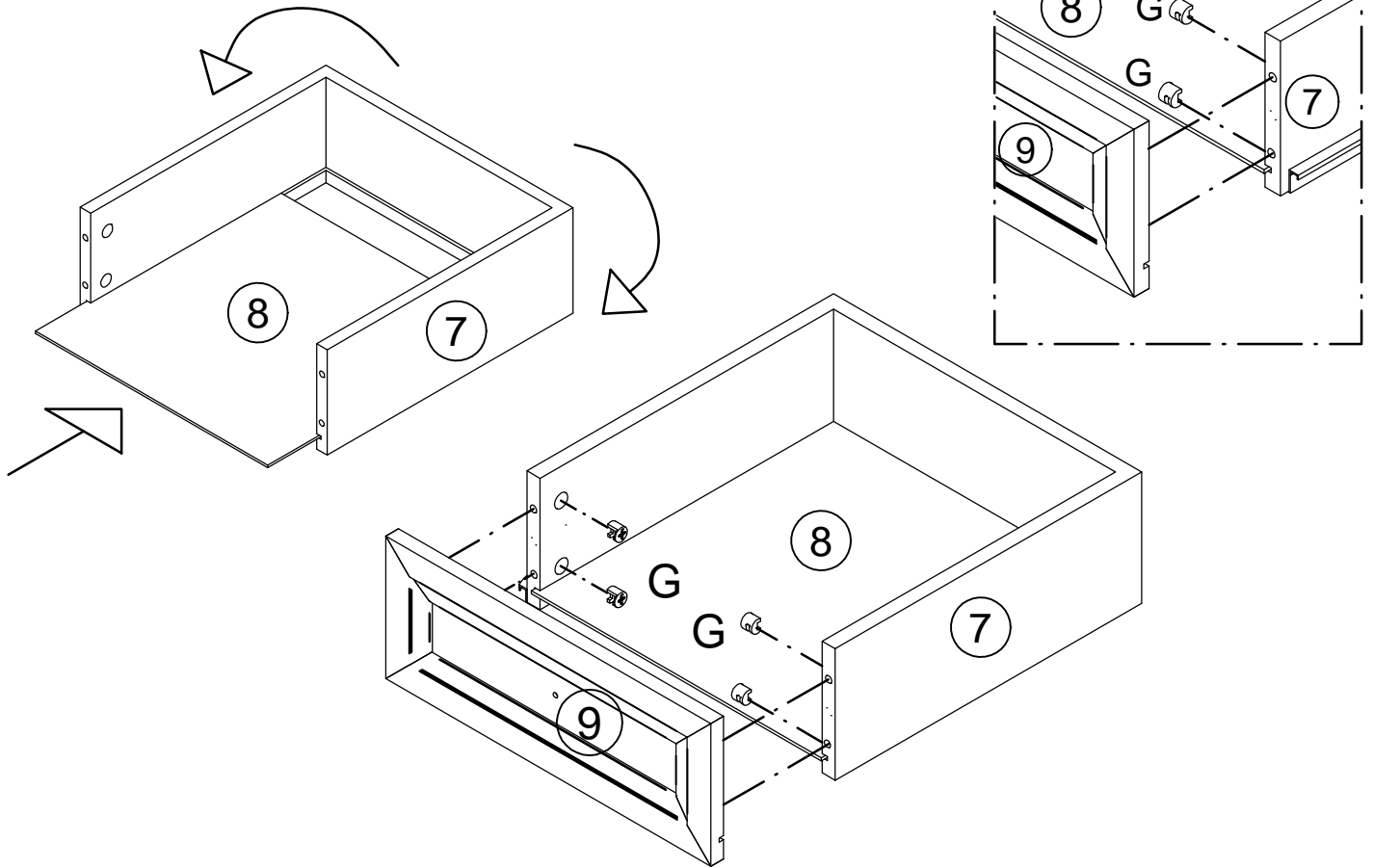

STEP 4. Secure sliders (L) to the bottom of part (7) using screw (C). Attach support (J) to the bottom of part (7) using screw (C). Attach handle (I) to the part (9) using screw (E).

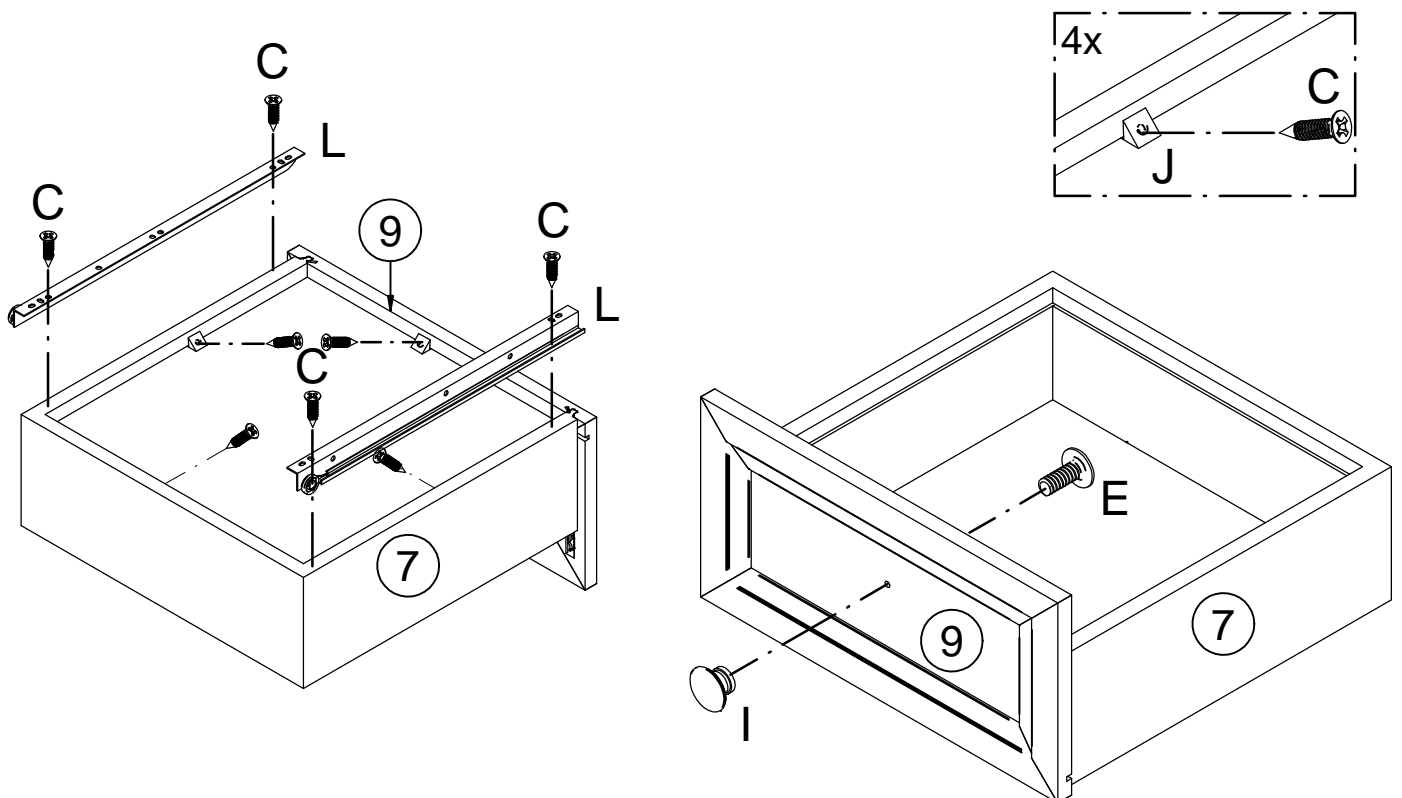

STEP 5. Secure hinge (K) to part (10) using screw (C), then attach handle (I) to part (10) using screw (E)

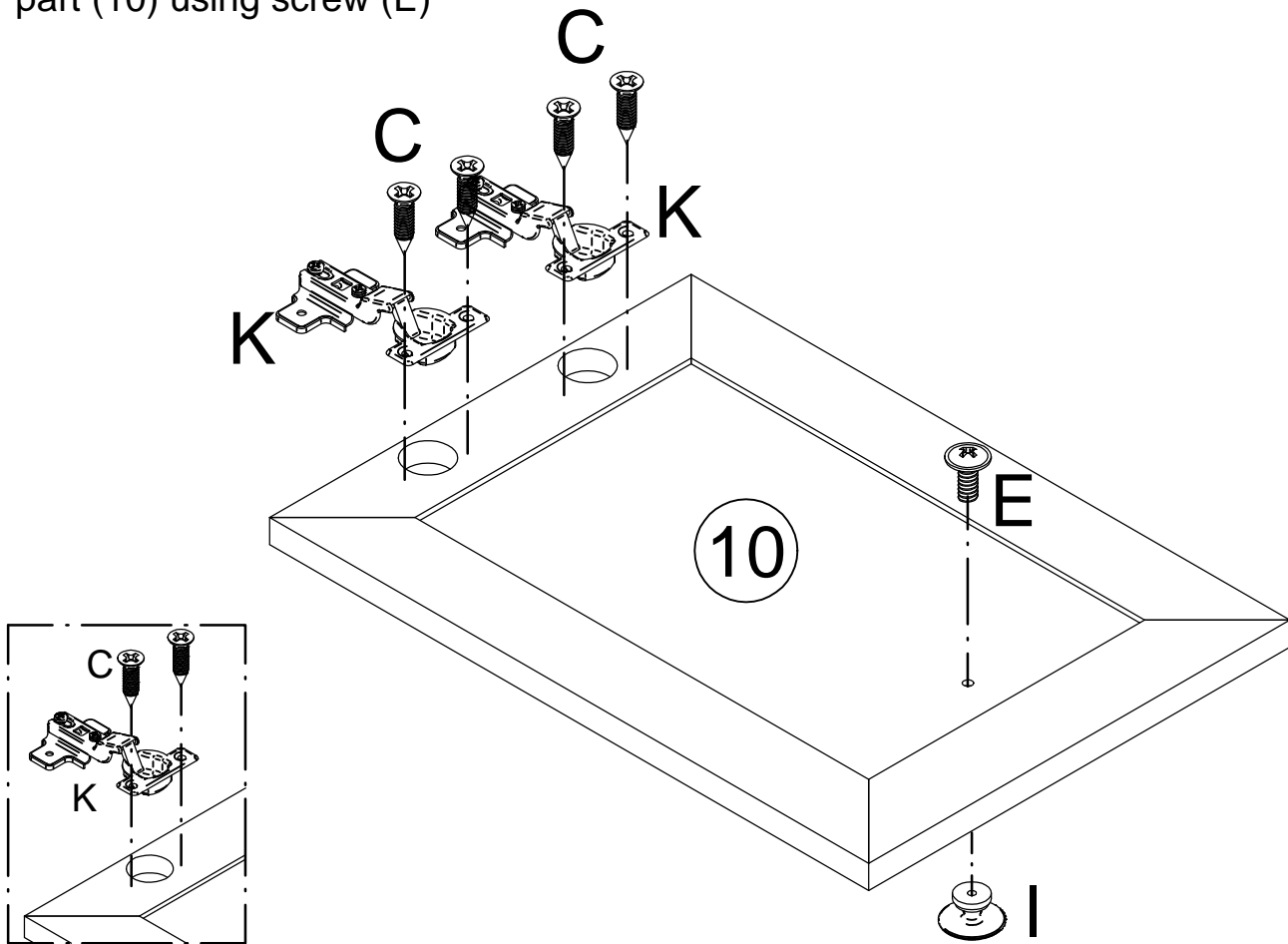

STEP 6. Secure parts (4,5) to part (1,2) using cam lock (G)

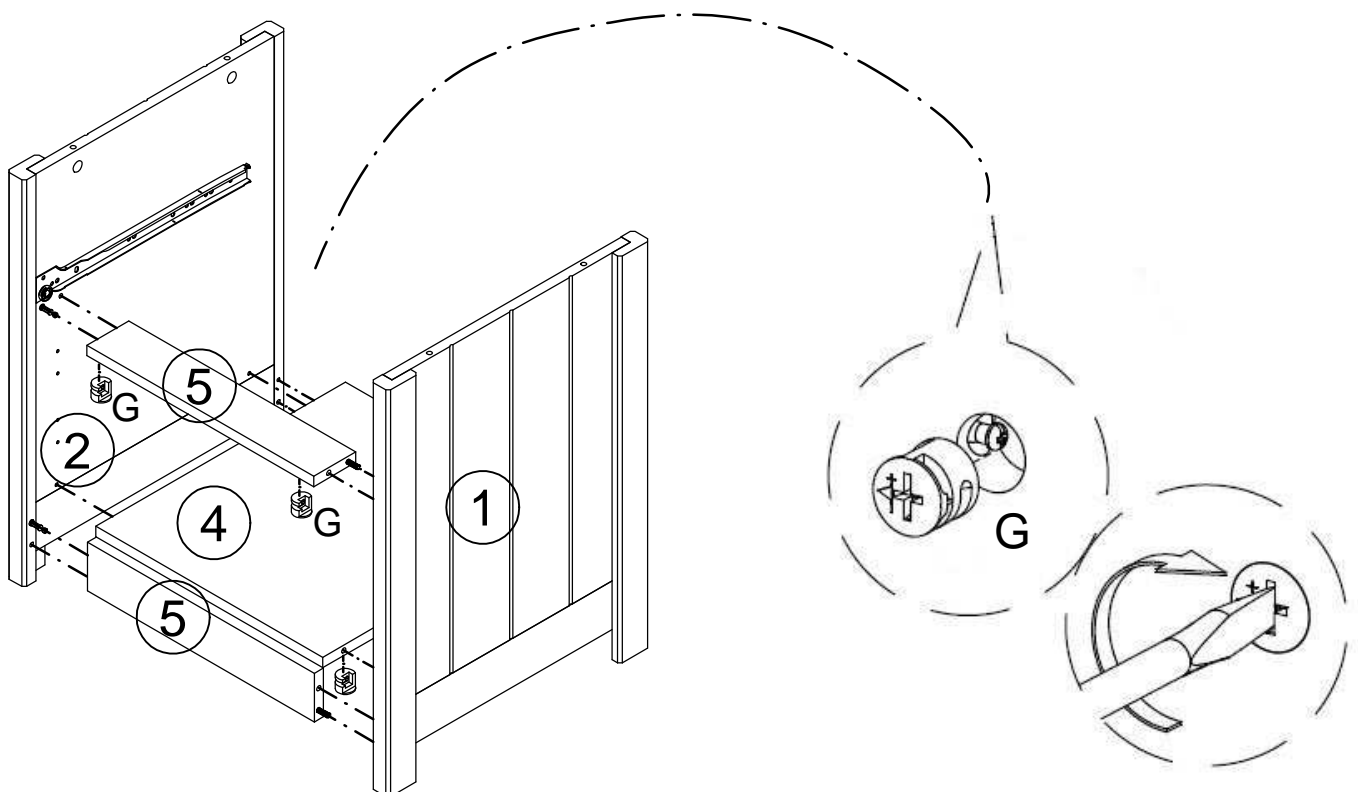

STEP 7. Secure part (3) to parts (1,2) using cam lock (G)

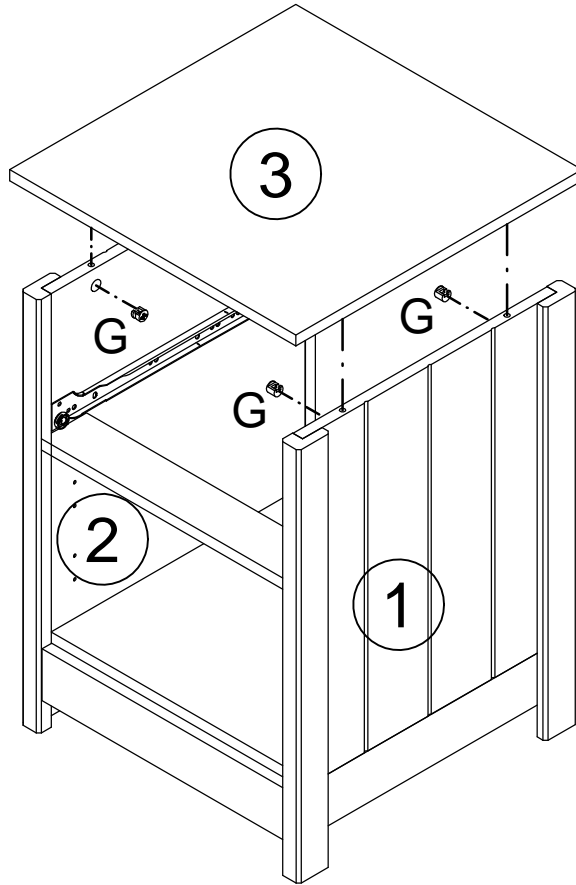

STEP 8. Attach back panel (6) to frame using nail (H)

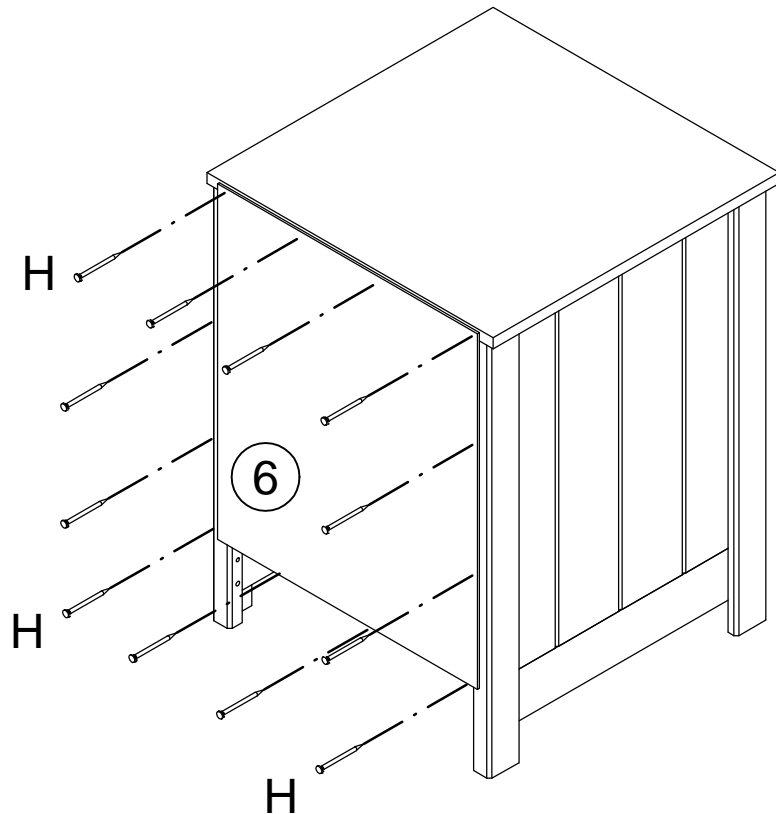

STEP 9. Attach door (10) to body using screws and fix the silicone backstop (M) to part (4).

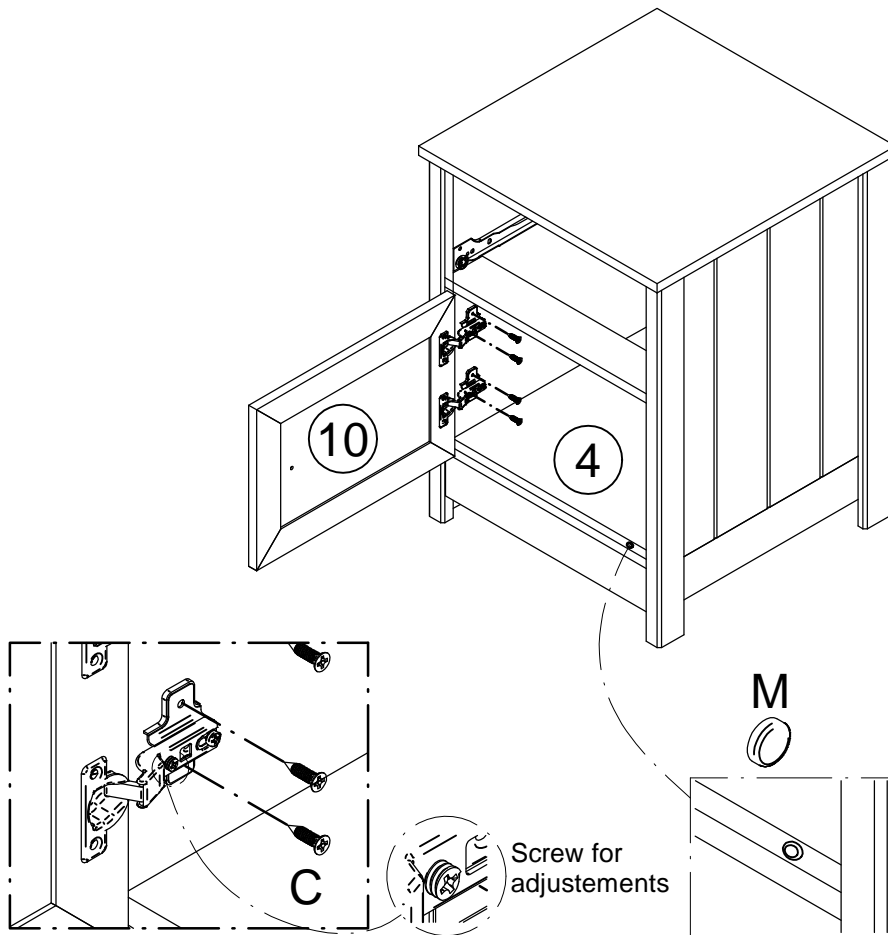

STEP 10. Insert drawer into frame.

