

ASSEMBLY INSTRUCTIONS

DINING TABLE

Please read instructions carefully



Remove all wrapping materials, staples and packing straps from the carton. Refer to Parts List and Hardware List and ensure they are complete before you start assembling. Place all wooden parts on a clean, flat and soft surface (e.g carpet or rug) to prevent parts from being scratched.

- CAUTIONS: 1) DO NOT FULLY TIGHTEN BOLTS AND NUTS UNTIL ALL PARTS HAVE BEEN ASSEMBLED.
 2) DO NOT OVER-TIGHTEN BOLTS AND NUTS UNTIL ALL PARTS HAVE BEEN ASSEMBLED.
 3) KEEP ALL HARDWARE PARTS OUT OF REACH OF CHILDREN.

PARTS LIST

NO.	COMPONENT	QTY.
P1	TABLE TOP	1
P2	TRESTLE LEG FRAME	2
P3	TOP RAIL	1
P4	TRESTLE STRETCHER	1
P5	ANGLED STRETCHER	2

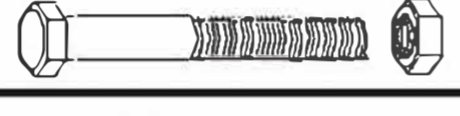
HARDWARE LIST

NO.	DESCRIPTION	QTY.
H1	M6 x 35 JCBC SCREW 	8
H2	BOLT & NUT 1/2" φ X 4" 	2
H3	M4 X 32 CSK SCREW 	13
H4	ALLEN KEY 	1

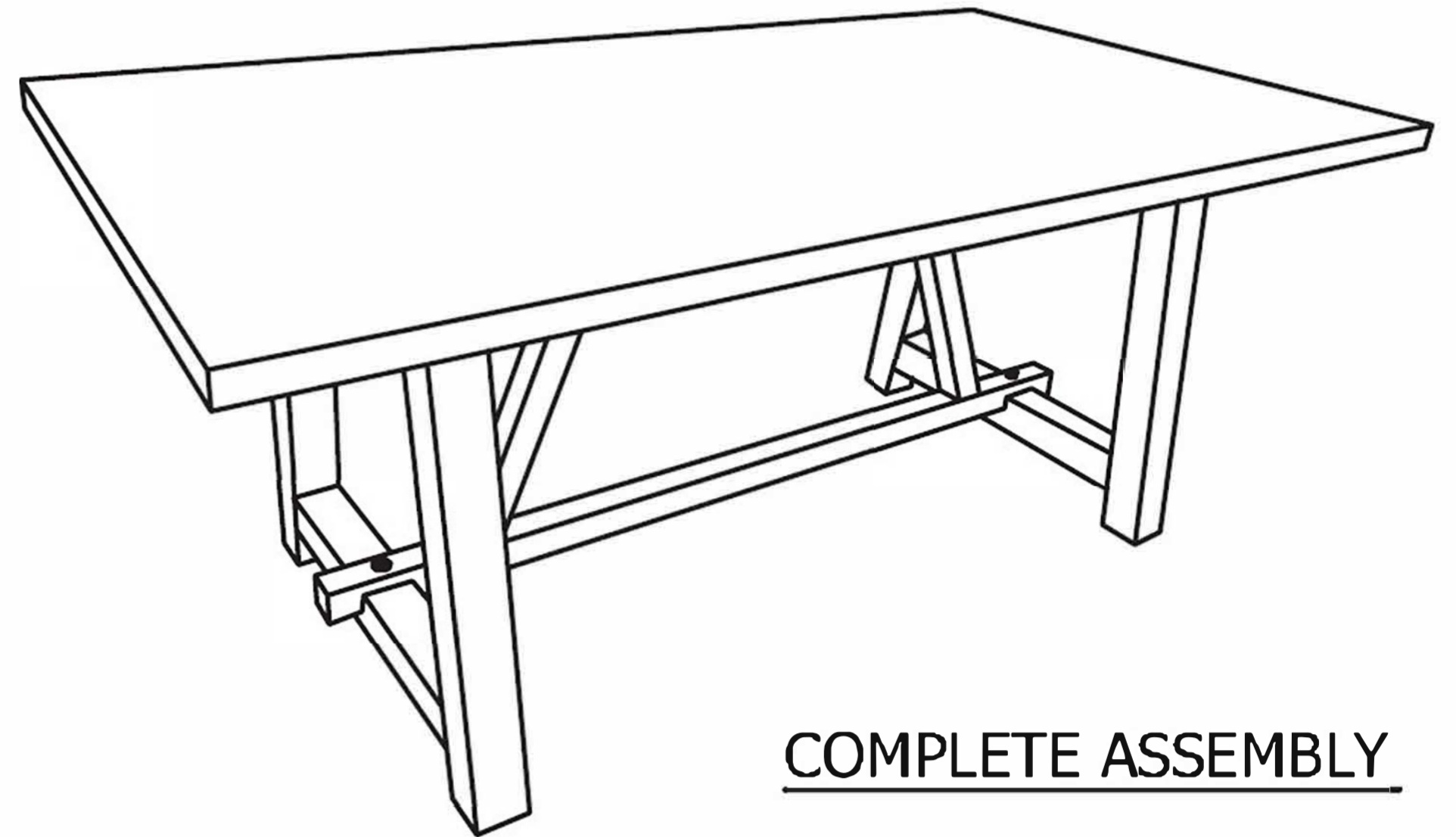

STEP 1

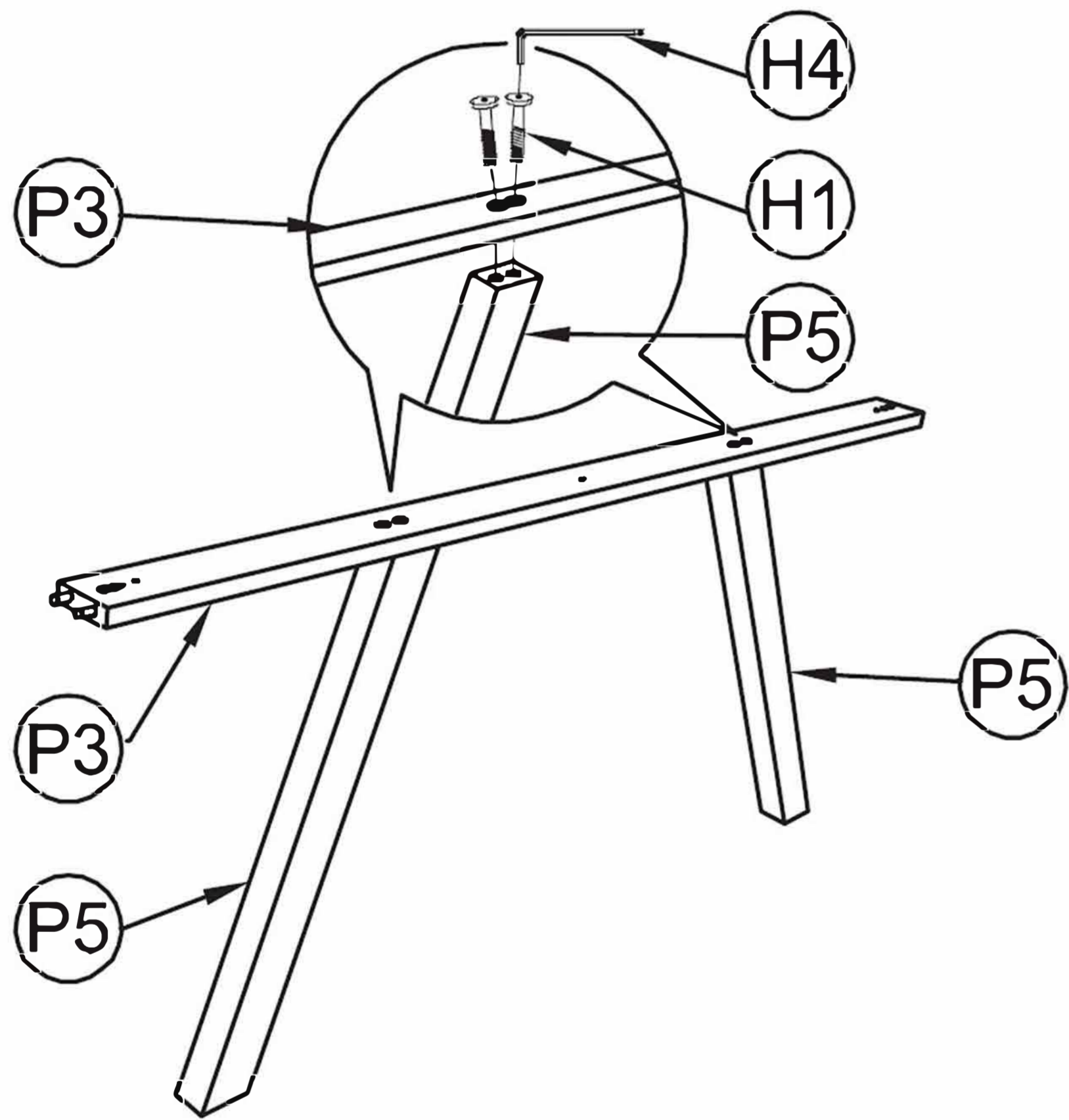

STEP 2

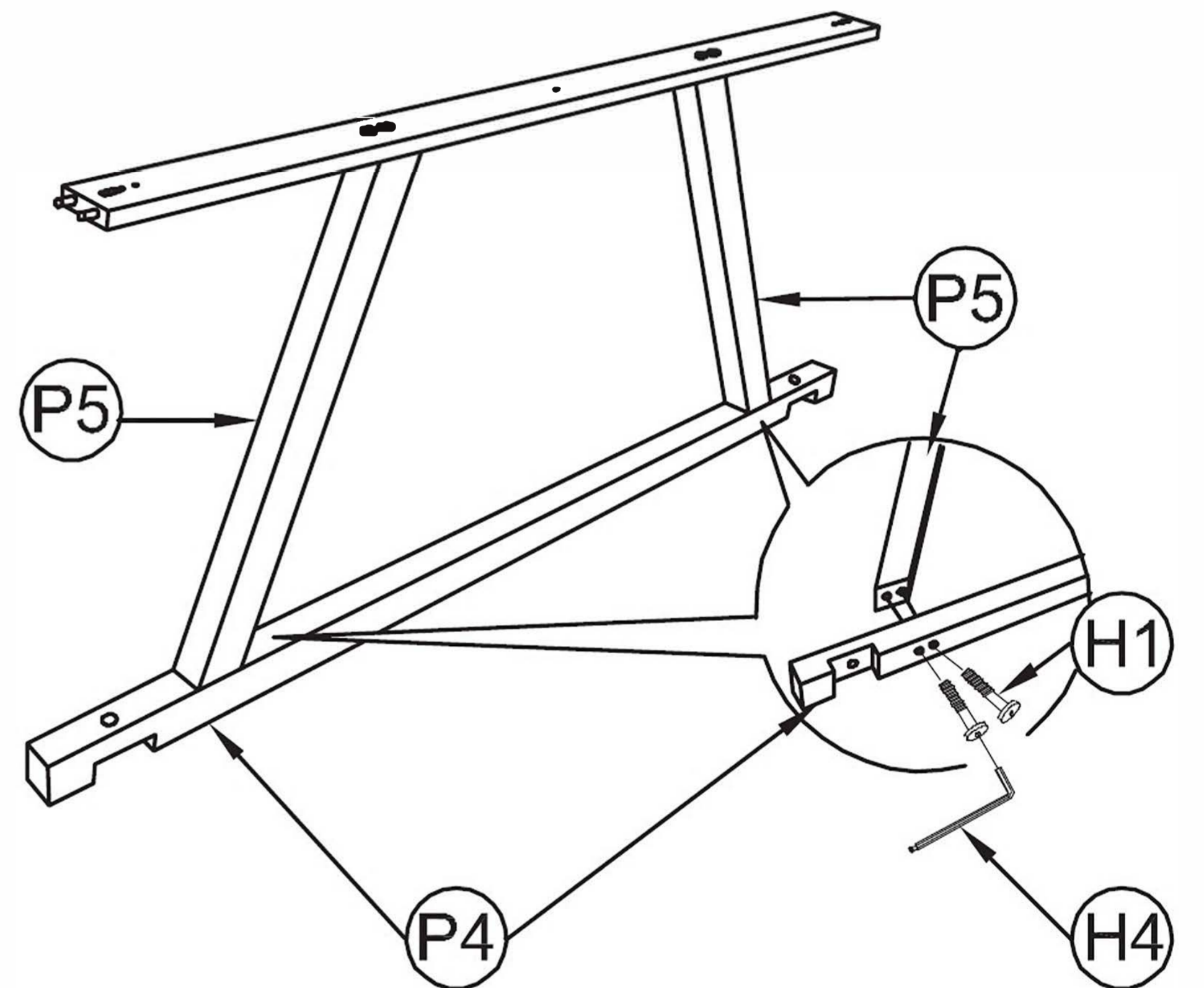

STEP 3

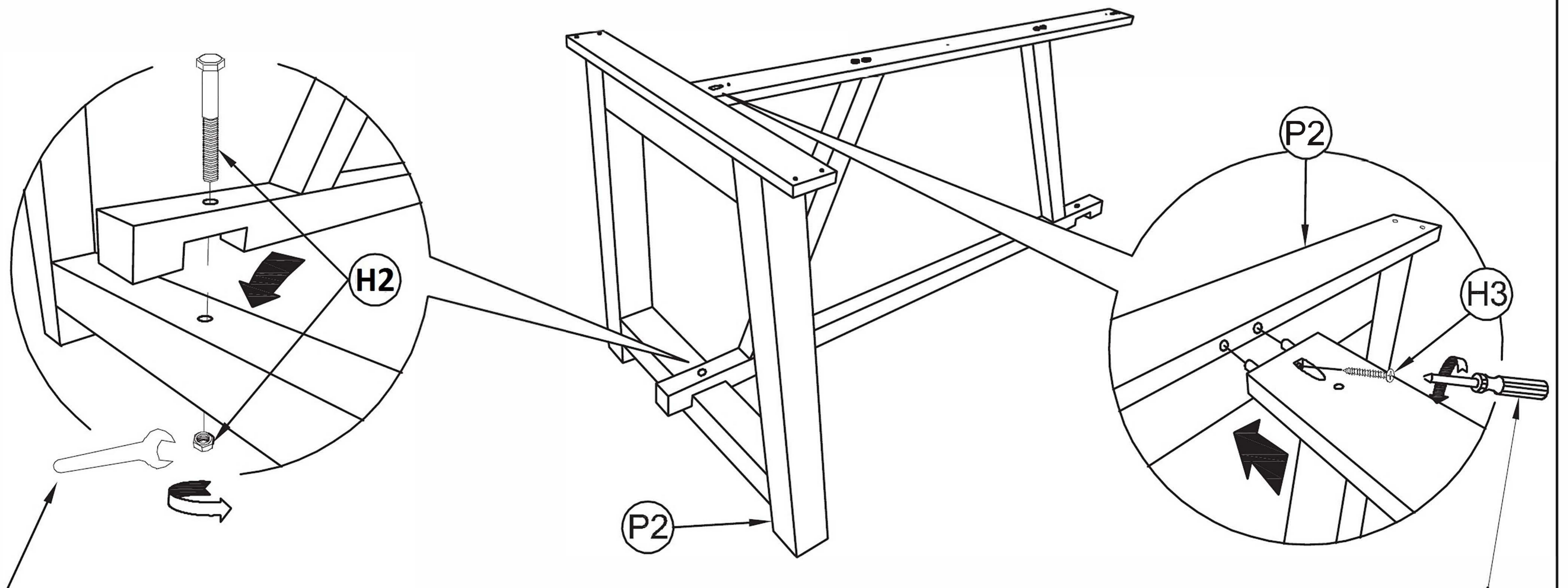

HOUSEHOLD WRENCH (not provided)

HOUSEHOLD SCREWDRIVER (not provided)

STEP 4

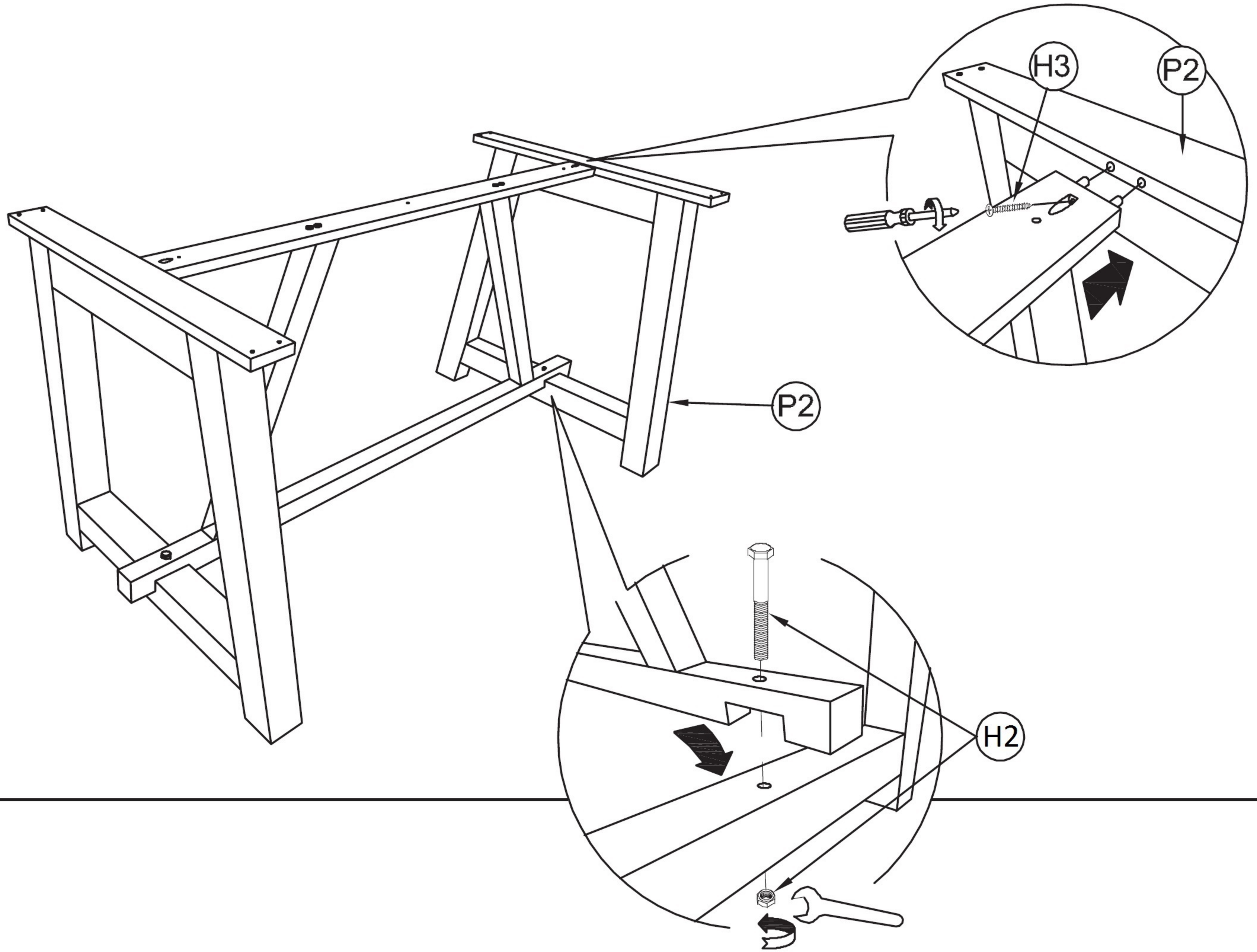

STEP 5

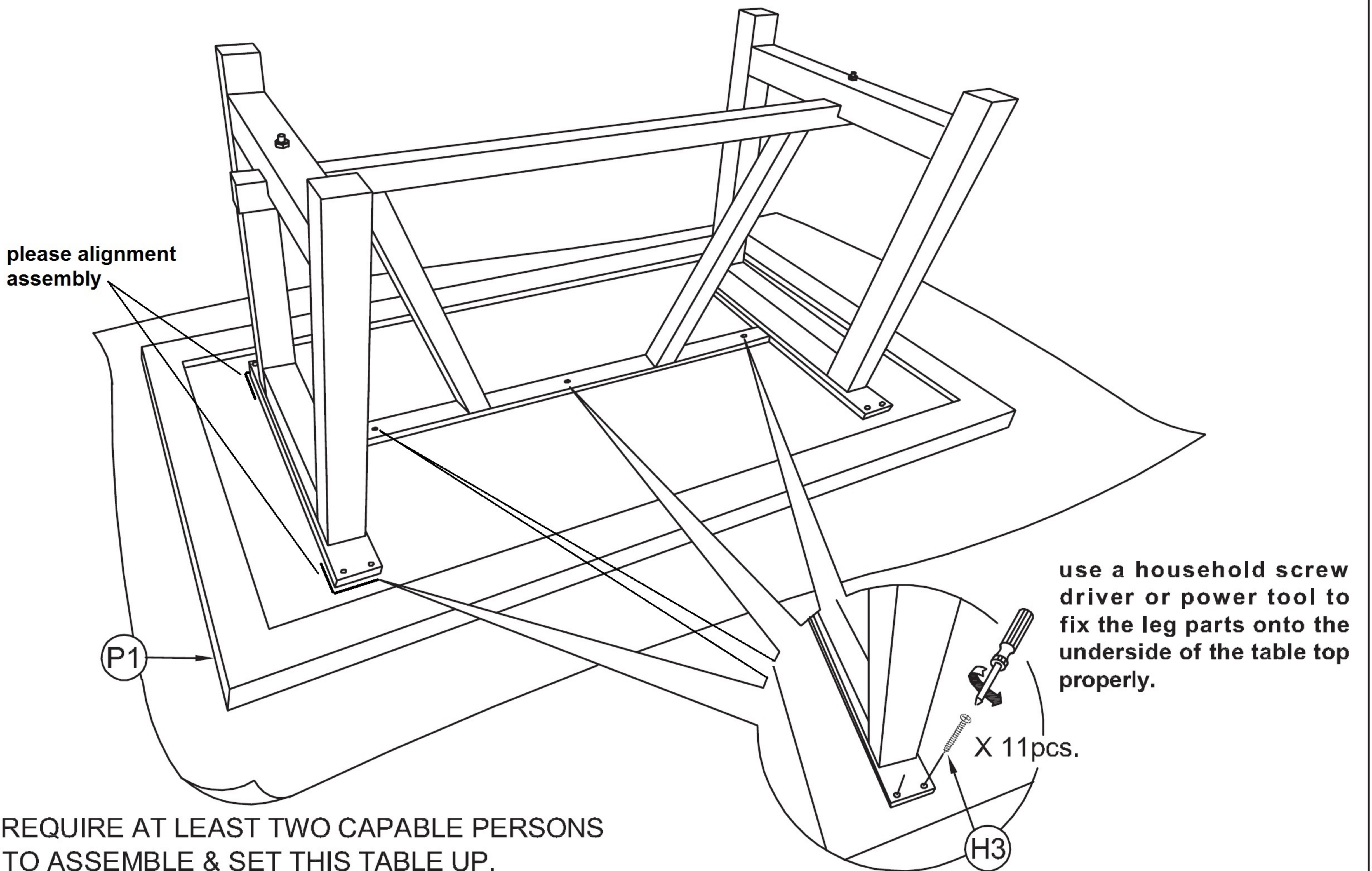

REQUIRE AT LEAST TWO CAPABLE PERSONS TO ASSEMBLE & SET THIS TABLE UP.

CARE AND MAINTENANCE

- SAFETY** - To avoid any risk of suffocation to children and animals, dispose off plastic bags immediately.
- CLEANING** - Clean with damp cloth and mild detergent. Do not use bleach or abrasive products.
- FITTINGS** - Tighten bolts and nuts from time to time to ensure all parts of product are securely fitted.

ASSEMBLY INSTRUCTIONS DINING CHAIR

Please read instructions carefully





Remove all wrapping materials, staples and packing straps from the carton. Refer to Parts List and Hardware List and ensure they are complete before you start assembling. Place all wooden parts on a clean, flat and soft surface (e.g carpet or rug) to prevent parts from being scratched.

- CAUTIONS: 1) DO NOT FULLY TIGHTEN BOLTS AND NUTS UNTIL ALL PARTS HAVE BEEN ASSEMBLED.
2) DO NOT OVER-TIGHTEN BOLTS AND NUTS UNTIL ALL PARTS HAVE BEEN ASSEMBLED.
3) KEEP ALL HARDWARE PARTS OUT OF REACH OF CHILDREN.

PARTS LIST (FOR 2 NOS. OF CHAIRS)

NO.	COMPONENT	QTY.
P1	CHAIR SEAT	2
P2	FRONT LEGS	4
P3	BACK LEG FRAMES	2

HARDWARE LIST (FOR 2 NOS. OF CHAIRS)

NO.	DESCRIPTION	QTY.
H1	M6 x 20 JCBC SCREW 	4
H2	M6 x 70 JCBC SCREW 	16
H3	SPRING WASHER 	20
H4	FLAT WASHER 2.0mm 	20
H5	ALLEN KEY 	1

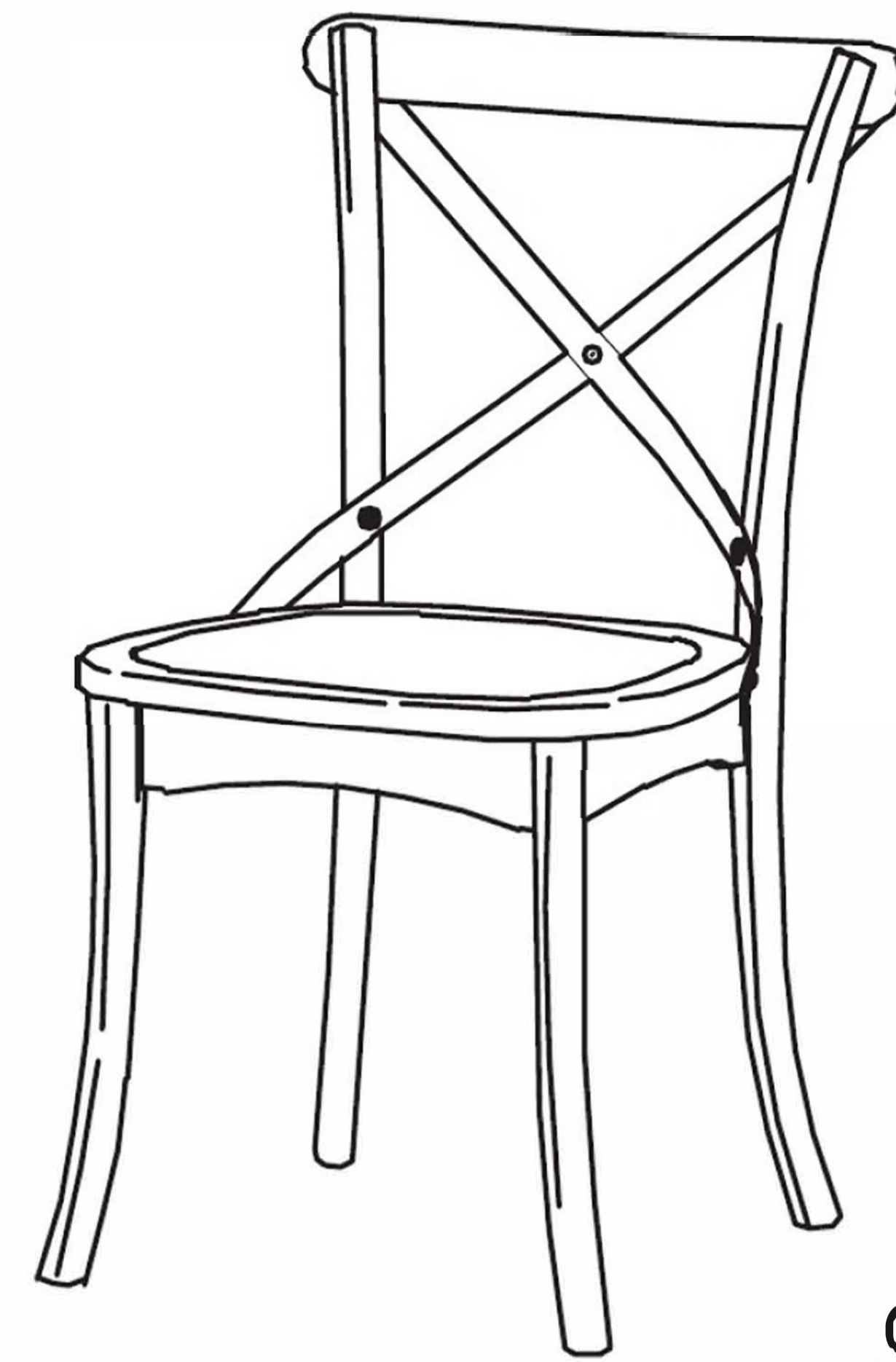

COMPLETE ASSEMBLY

STEP 1

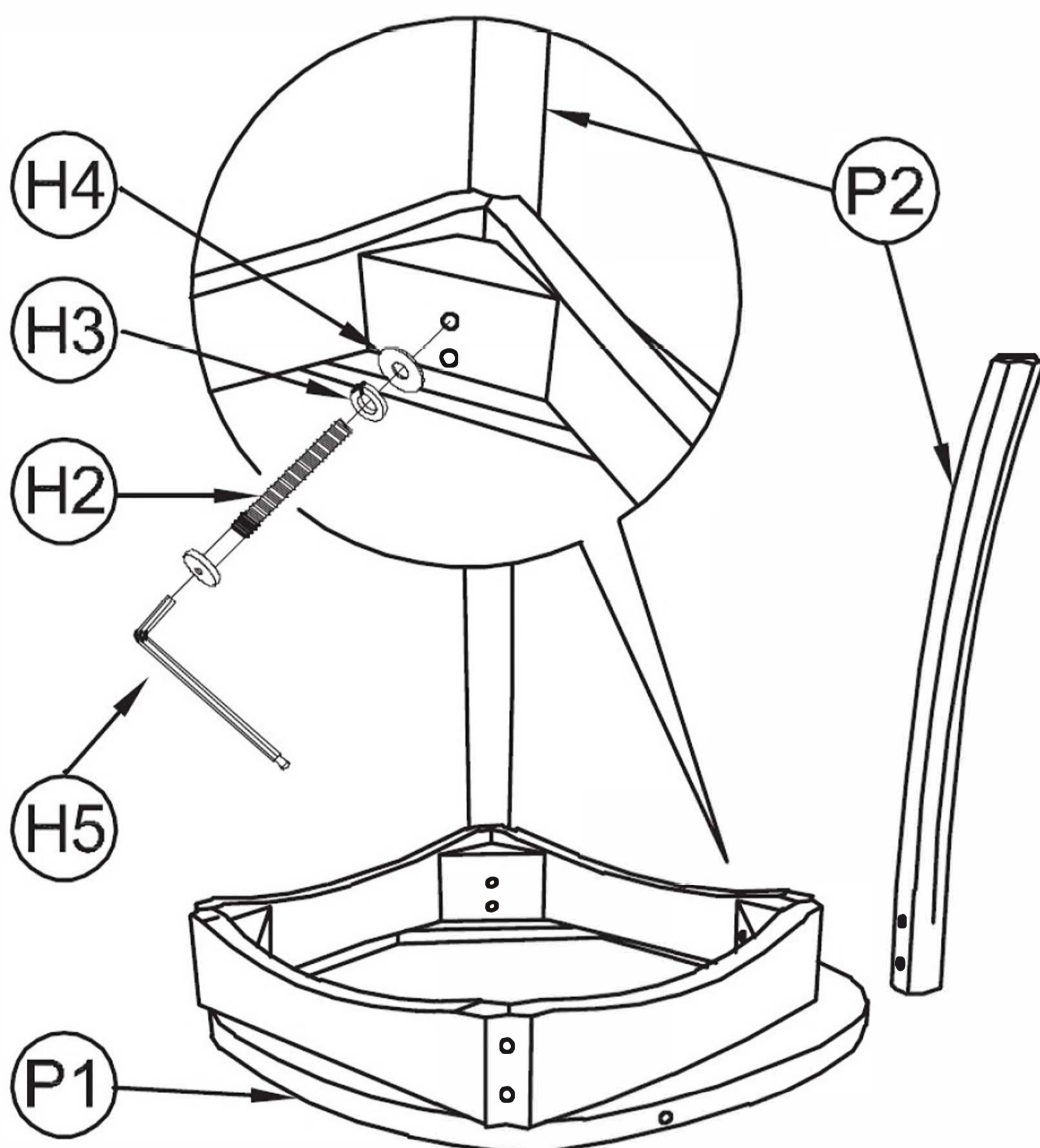

STEP 2

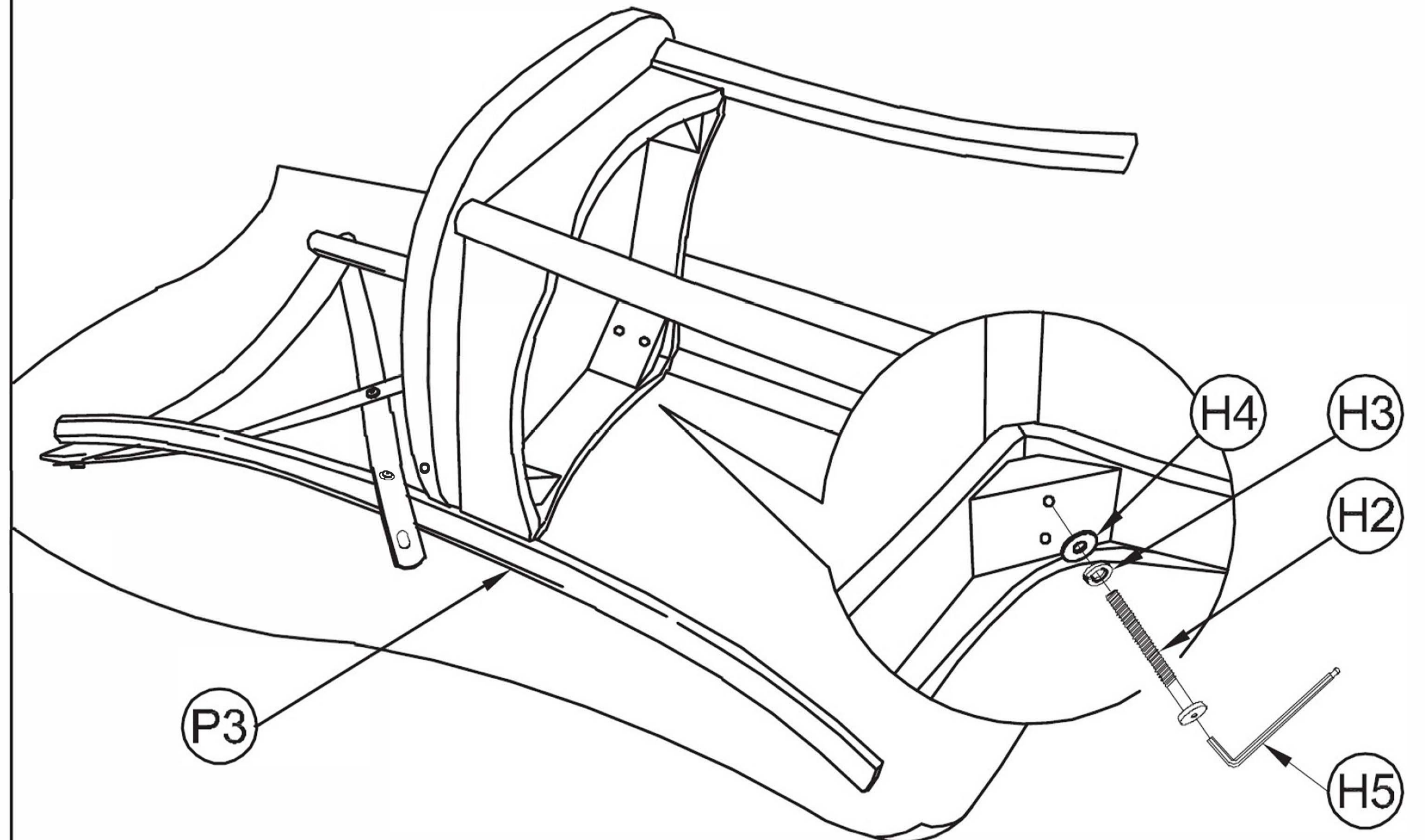

STEP 3

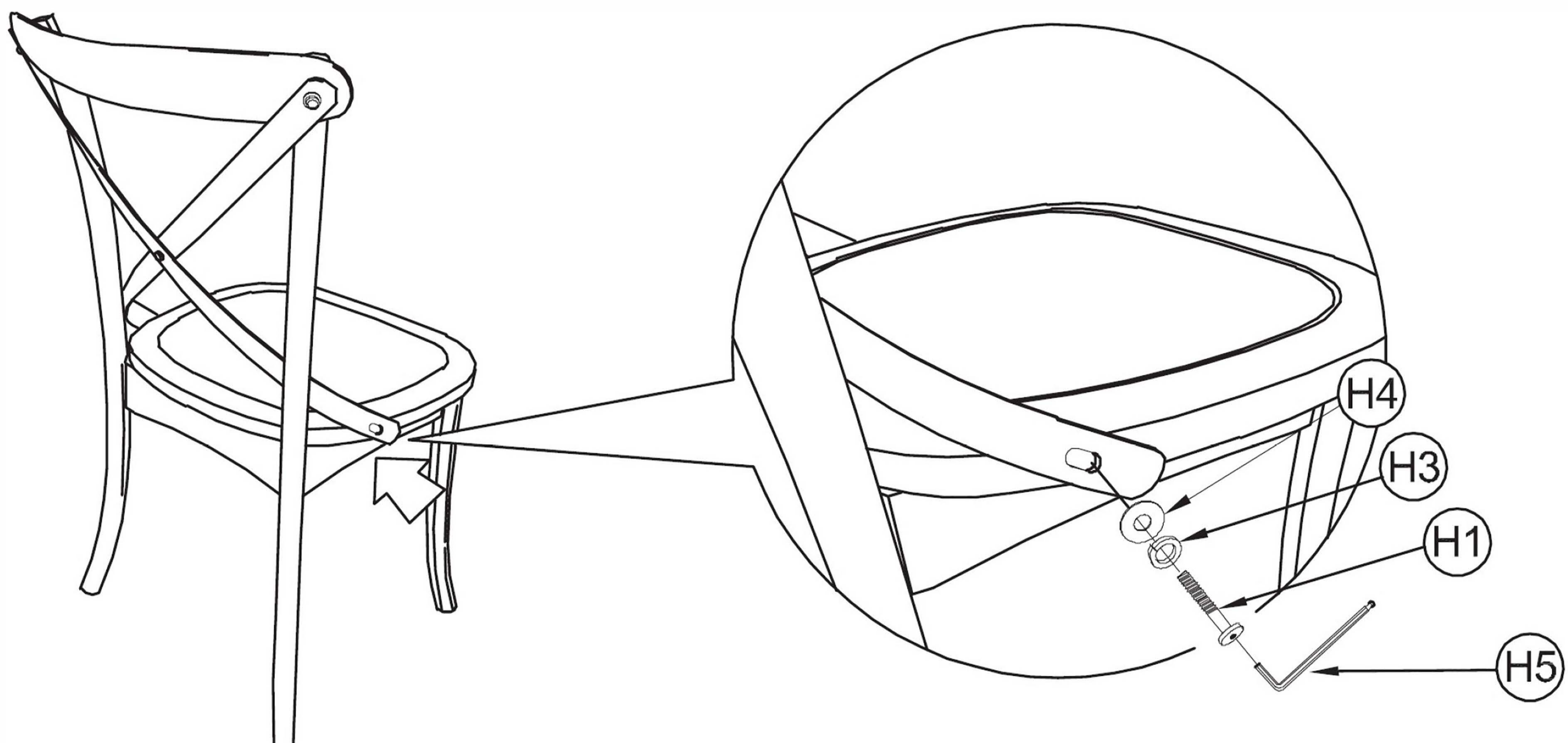

CARE AND MAINTENANCE

- SAFETY** - To avoid any risk of suffocation to children and animals, dispose off plastic bags immediately.
CLEANING - Clean with damp cloth and mild detergent. Do not use bleach or abrasive products.
FITTINGS - Tighten bolts and nuts from time to time to ensure all parts of product are securely fitted.

DO NOT FULLY TIGHTEN BOLTS AND NUTS UNTIL ALL PARTS HAVE BEEN ASSEMBLED.