

Assembly Instructions

Bookshelf

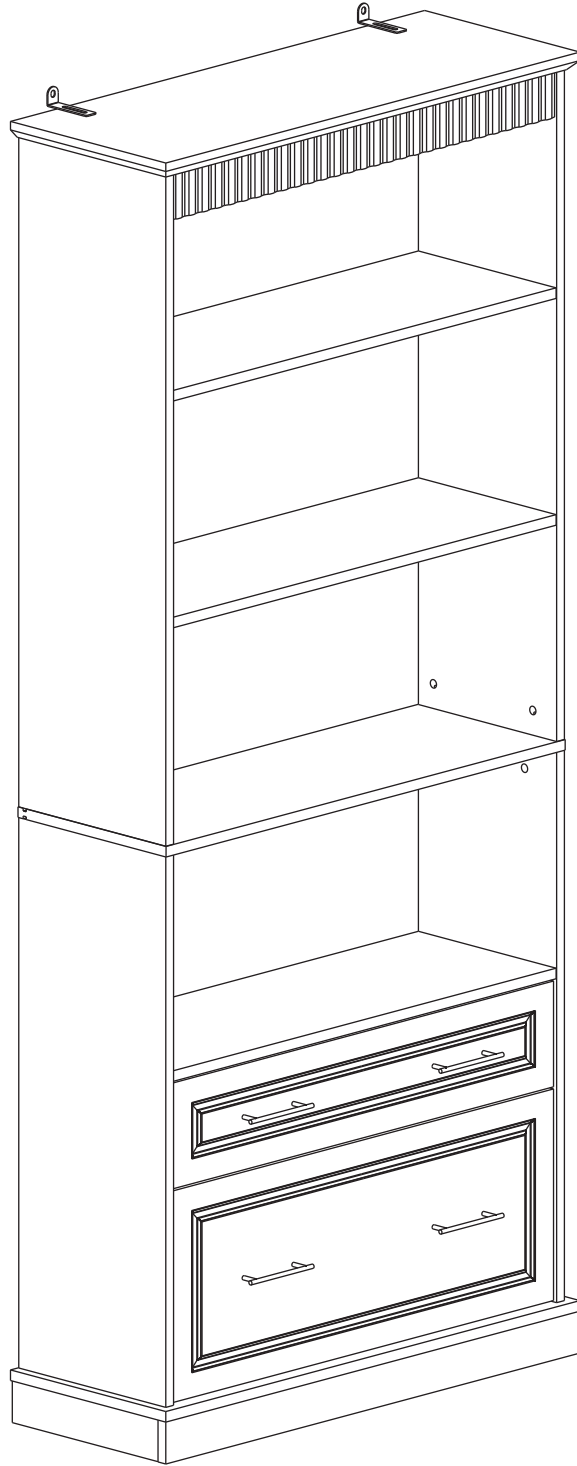

Contact Us

We're here to help you.

Your satisfaction is our top priority. If you encounter any issues with this product, such as missing or damaged parts, we're here to help. Please retain the original packaging and take photos of the packaging and the product, then contact us as soon as possible.

Warm Tips

1. Carefully read these instructions and keep them for future reference.
2. Check the parts list and confirm everything's there before starting assembly.
3. When assembling, put all parts on a soft, smooth surface like a carpet to avoid scratches.
4. Don't fully tighten screws until all parts are confirmed in place to avoid misalignment.

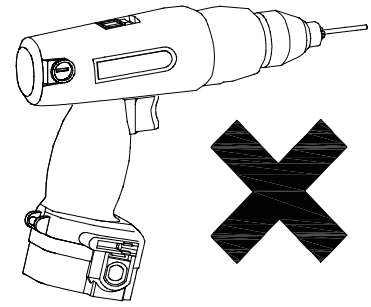
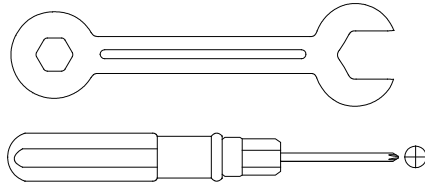
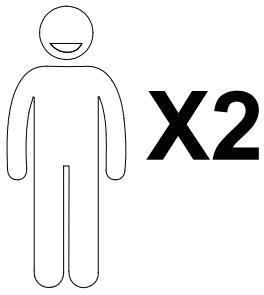

We recommend using hand tools for assembly.

If an electric screwdriver is used, reduce power and torque to avoid damage to the product.

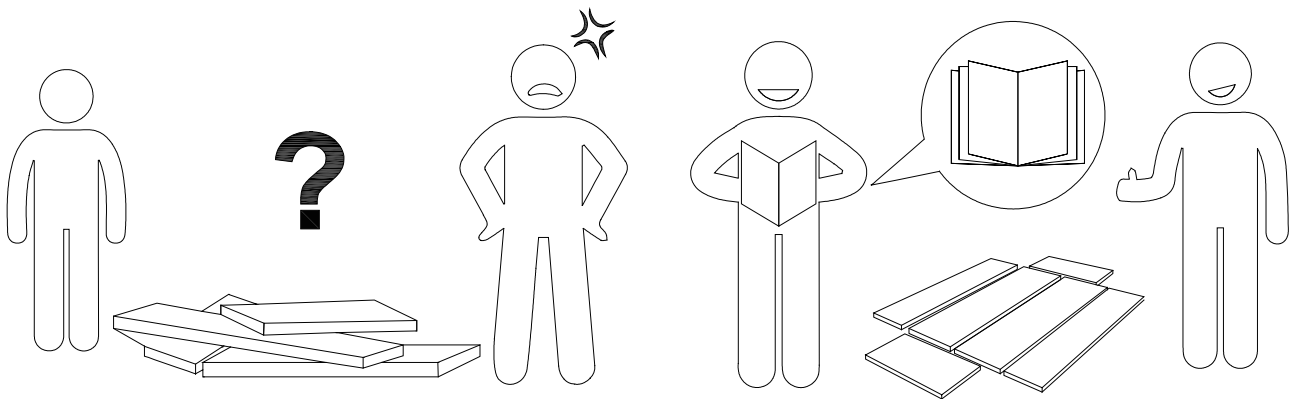

Install the Anti-Tip Straps

Using the anti-tip straps can reduce the risk of tipping over, but can not eliminate it.

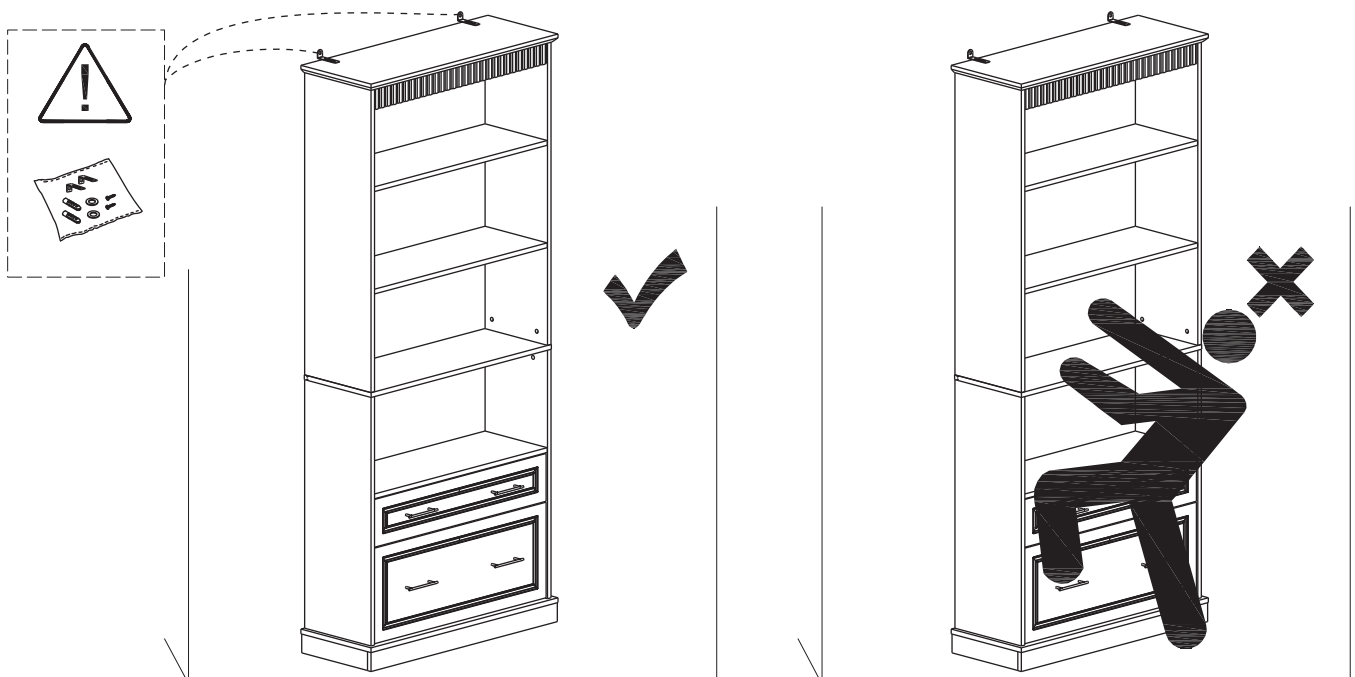

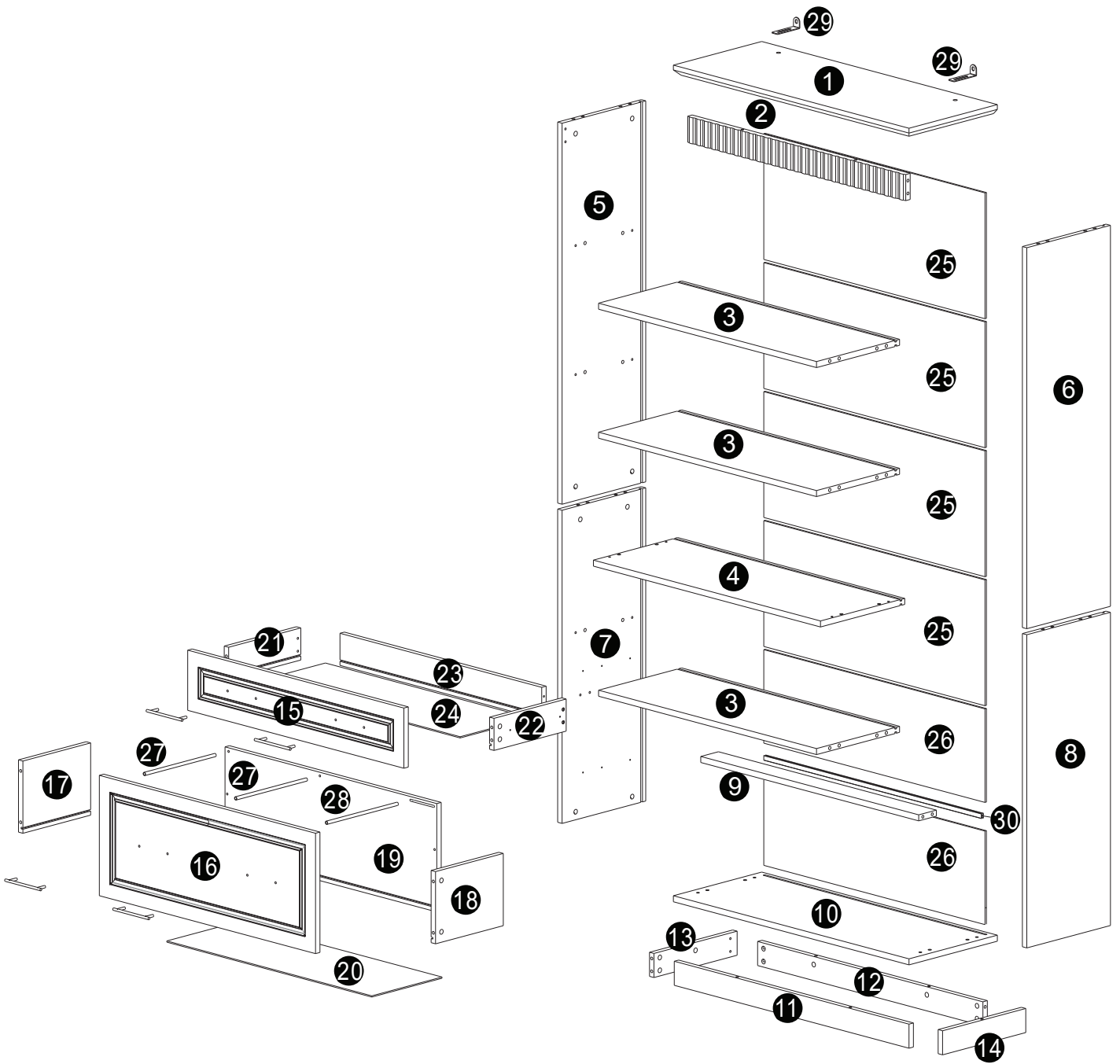







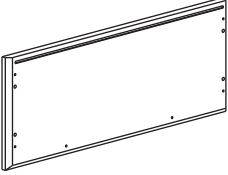
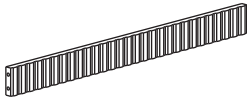
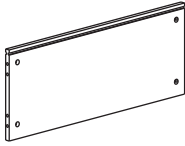
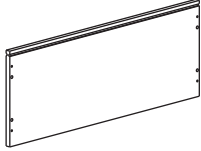



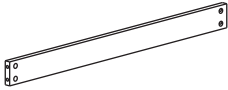
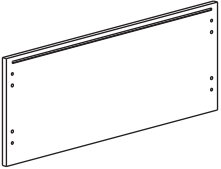
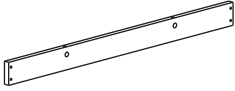
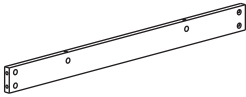
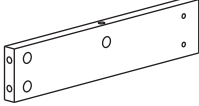
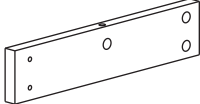
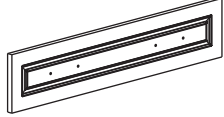
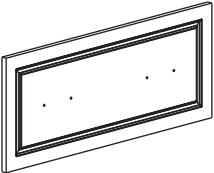
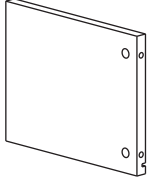
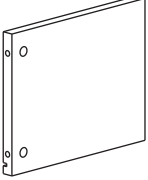
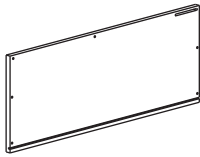
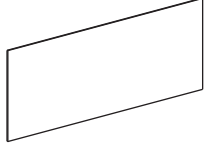
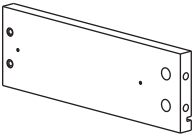
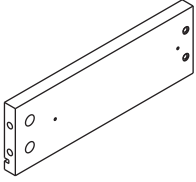
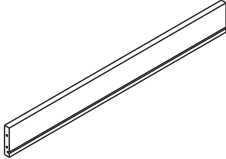
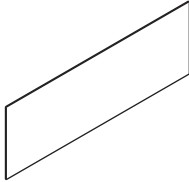
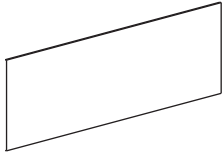
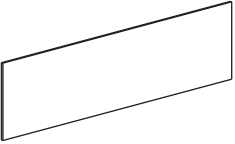
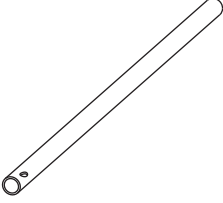
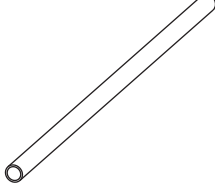
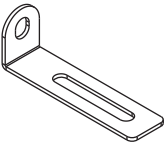
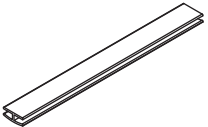



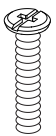

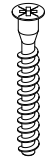

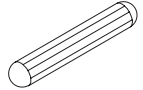

⚠ Caution

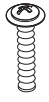
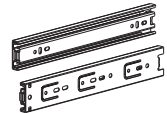
Make sure all parts are included. Most board parts are labeled or stamped on the raw edge. Contact us for a free replacement if you encounter any damaged or missing parts.

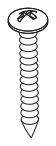
Parts List

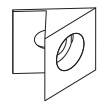
<p>1</p>  <p>1 pc</p>	<p>2</p>  <p>1 pc</p>	<p>3</p>  <p>3 pcs</p>	<p>4</p>  <p>1 pc</p>	<p>5</p>  <p>1 pc</p>
<p>6</p>  <p>1 pc</p>	<p>7</p>  <p>1 pc</p>	<p>8</p>  <p>1 pc</p>	<p>9</p>  <p>1 pc</p>	<p>10</p>  <p>1 pc</p>
<p>11</p>  <p>1 pc</p>	<p>12</p>  <p>1 pc</p>	<p>13</p>  <p>1 pc</p>	<p>14</p>  <p>1 pc</p>	<p>15</p>  <p>1 pc</p>
<p>16</p>  <p>1 pc</p>	<p>17</p>  <p>1 pc</p>	<p>18</p>  <p>1 pc</p>	<p>19</p>  <p>1 pc</p>	<p>20</p>  <p>1 pc</p>
<p>21</p>  <p>1 pc</p>	<p>22</p>  <p>1 pc</p>	<p>23</p>  <p>1 pc</p>	<p>24</p>  <p>1 pc</p>	<p>25</p>  <p>4 pcs</p>
<p>26</p>  <p>2 pcs</p>	<p>27</p>  <p>2 pcs</p>	<p>28</p>  <p>1 pc</p>	<p>29</p>  <p>2 pcs</p>	<p>30</p>  <p>1 pc</p>

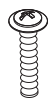
Hardware List

A	B	C	D	E	F
					
M6×40mm	M6×12mm	Ø5×38mm	Ø6×44.5mm	15mm	Ø6×28mm
4 pcs	2 pcs	8 pcs	24 pcs	24 pcs	32 pcs
G	H	I	J	K	L
					
12mm	Ø8×30mm		M4×18mm		M3.5×14mm
32 pcs	28 pcs	4 pcs	8 pcs	2 Sets	54 pcs
M	N	O	P	Q	R
					
Ø4×24.5mm	Ø16×Ø6.2mm			Ø21mm	Ø21mm
2 pcs	4 pcs	2 pcs	34 pcs	16 pcs	12 pcs
S	T				
					
M4×28mm					
1pc	1pc				

Installation of Cams and Pins

Read each step carefully before starting. Each step of instruction should be performed in the correct order. If these steps are not followed in sequence, assembly difficulties may occur.

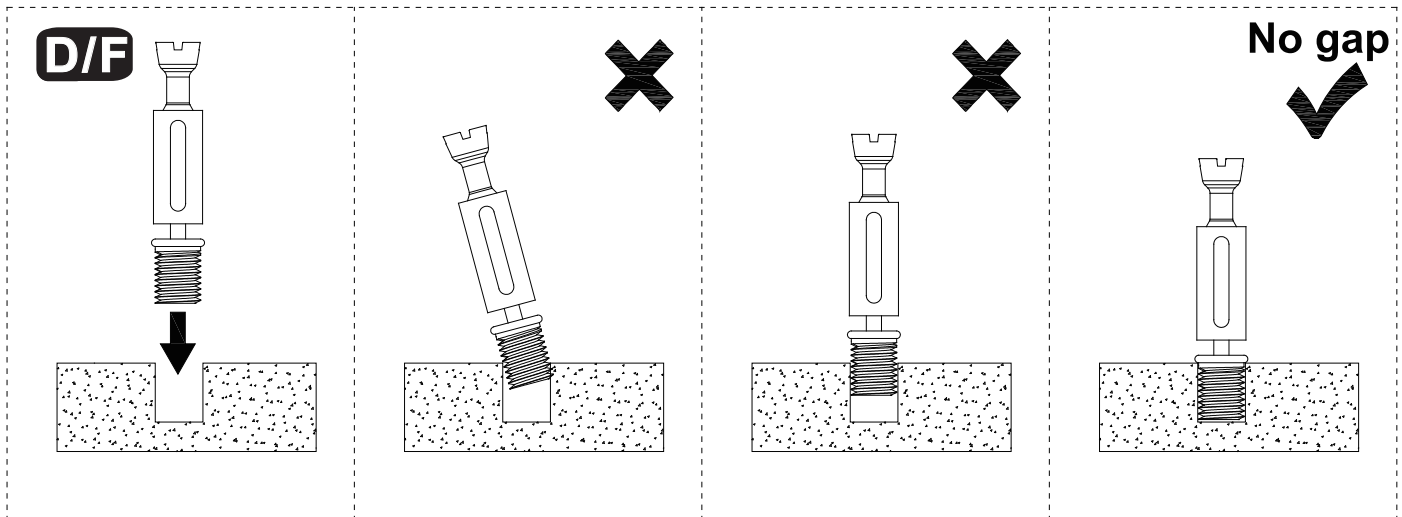
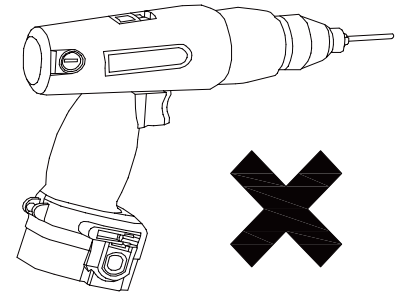

Screw the pin into the hole. Set the cams correctly by aligning the head of the cams with the lock pins. Lock the cam by turning the cam head with a screwdriver until it is tightened. Please do not use an electric screwdriver to assemble the unit.

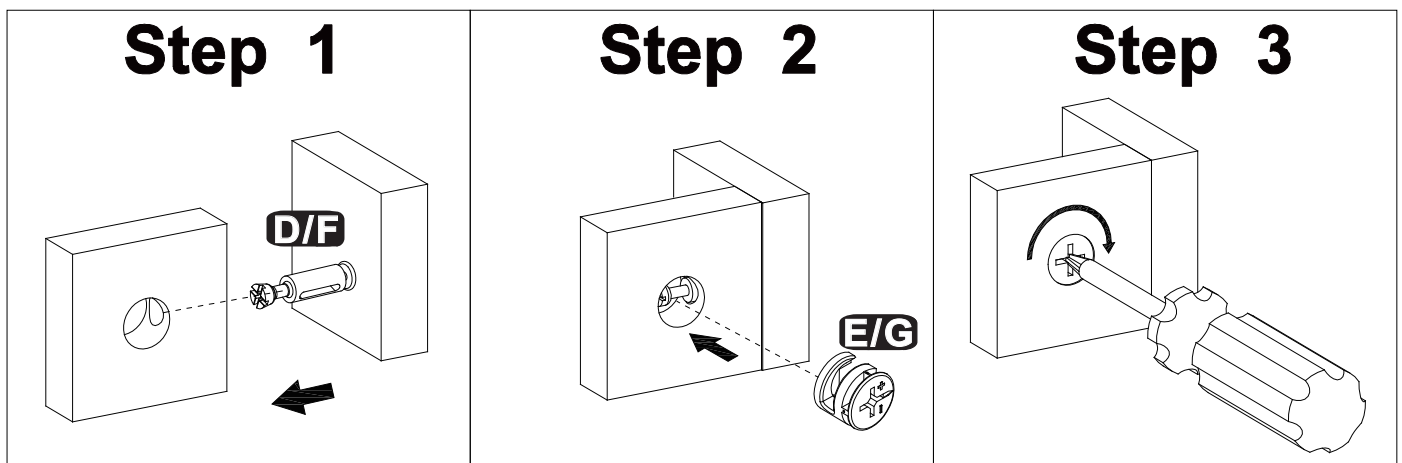

Please split component “K” into “K-a” and “K-b” before assembling the slide and then proceed to the next step of assembly

Step 1

Pull apart component "K" to each side, and then gently push up the lever of component "K-b"

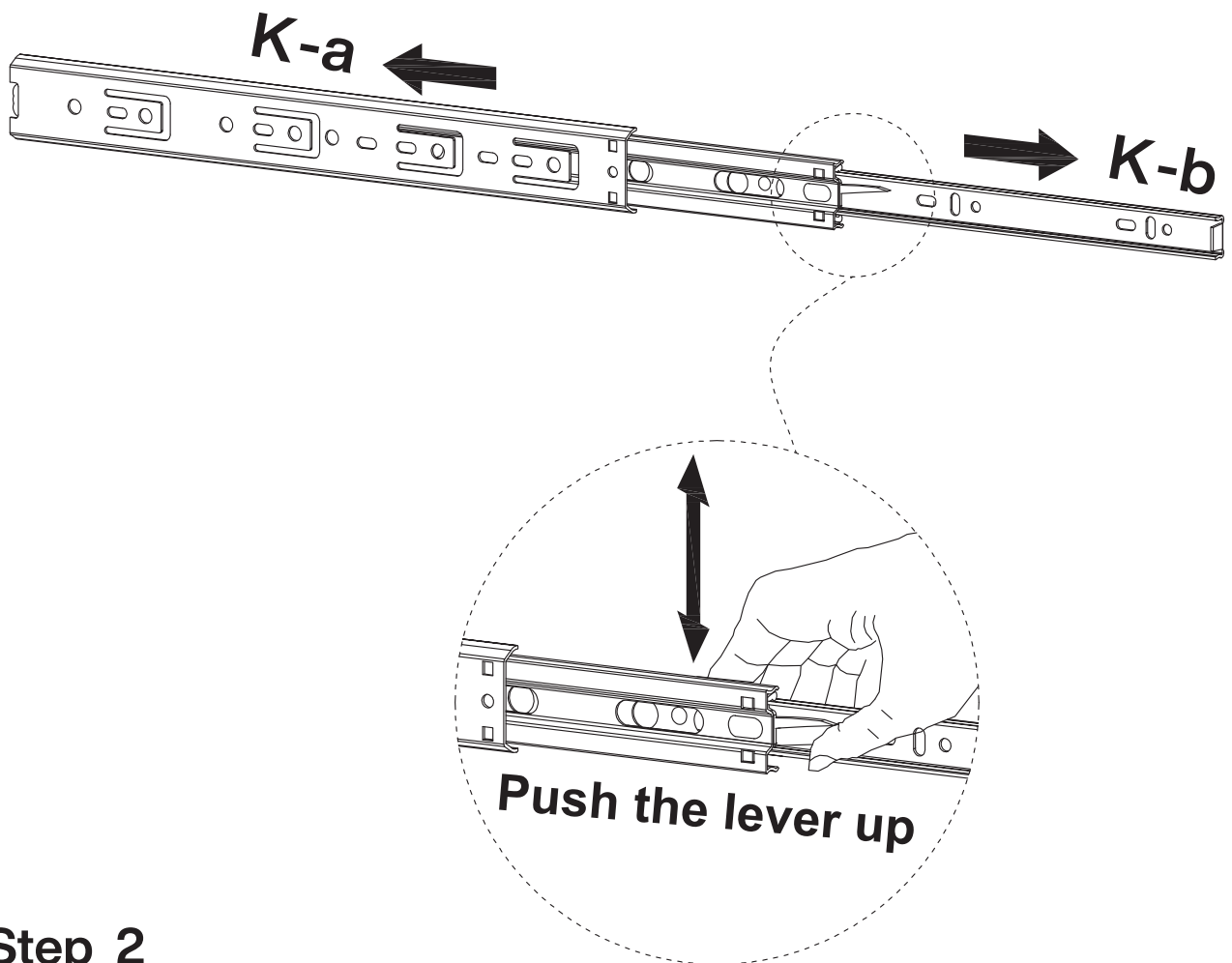

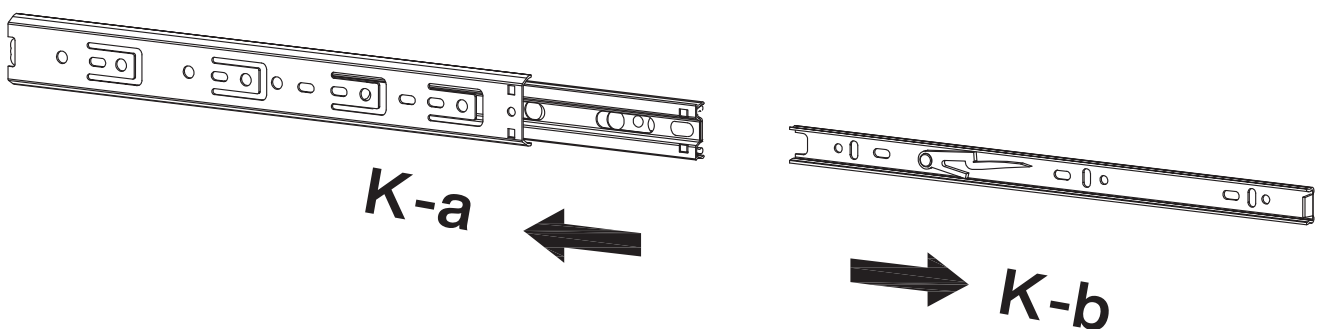

Step 2

Split component “K-a” and “K-b”

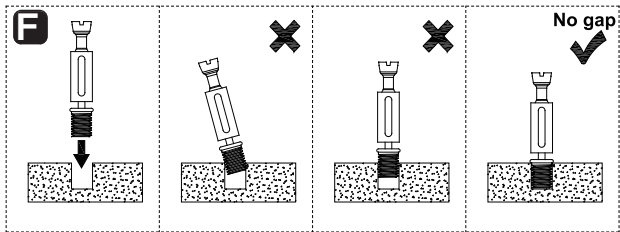

1

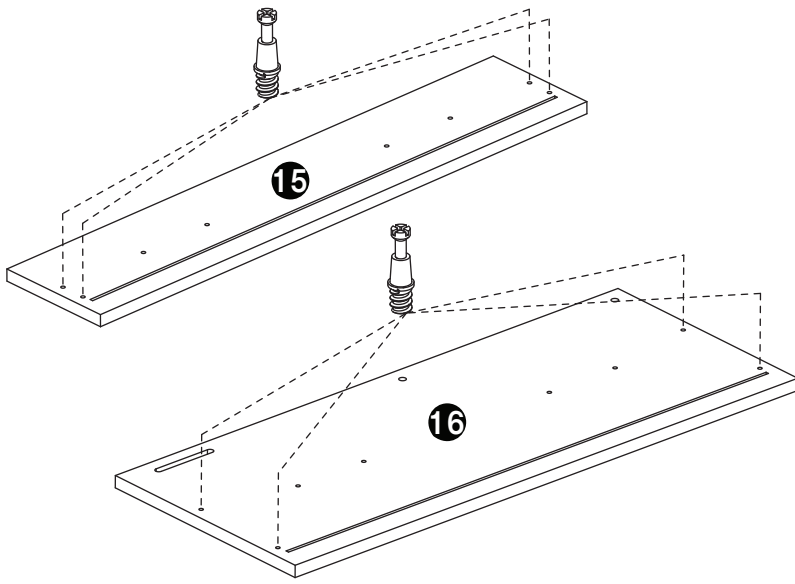

F

Ø6x28mm
8 pcs

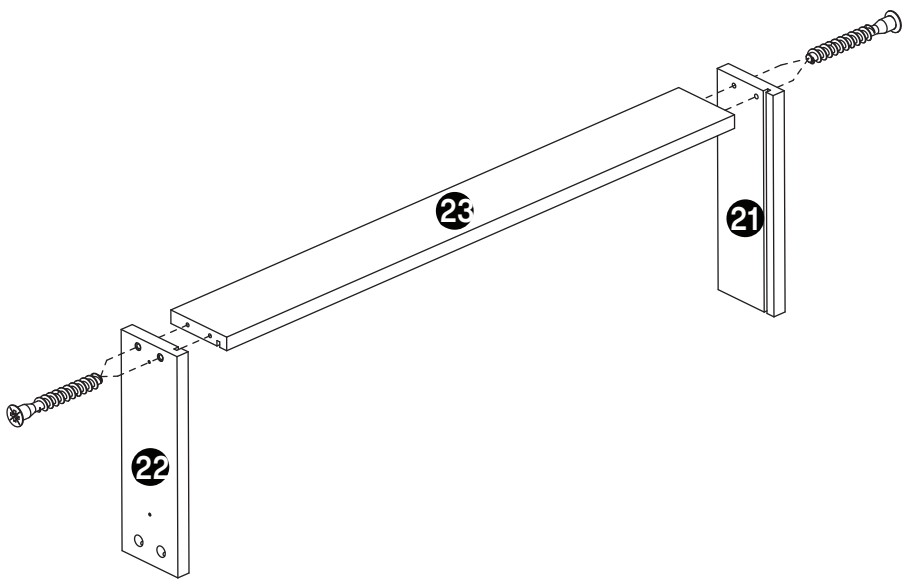

2

C

Ø5x38mm
4 pcs

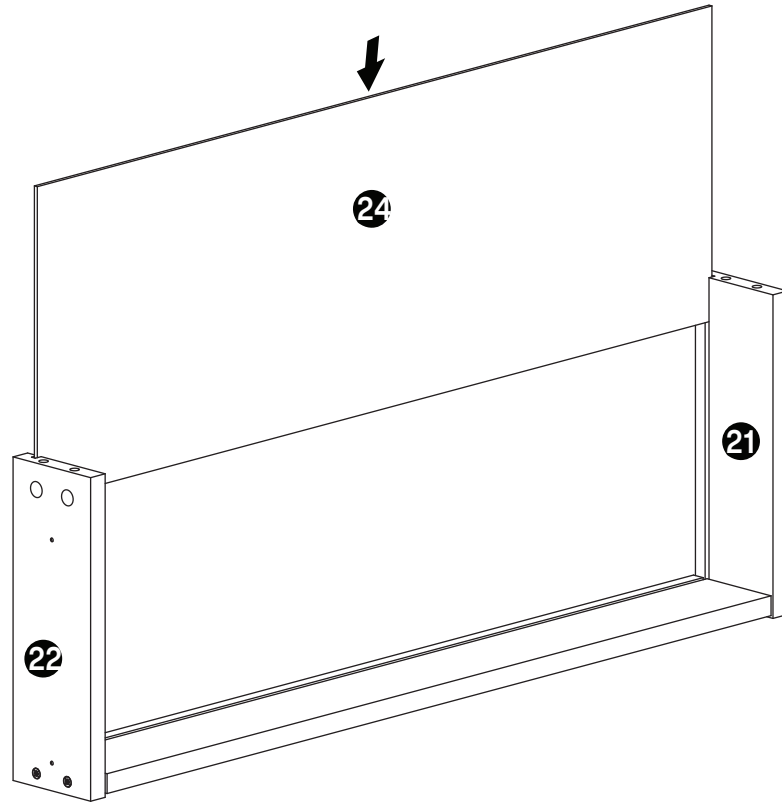

3

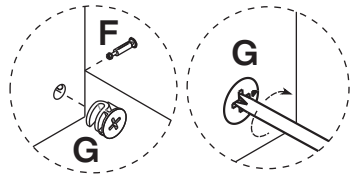

4



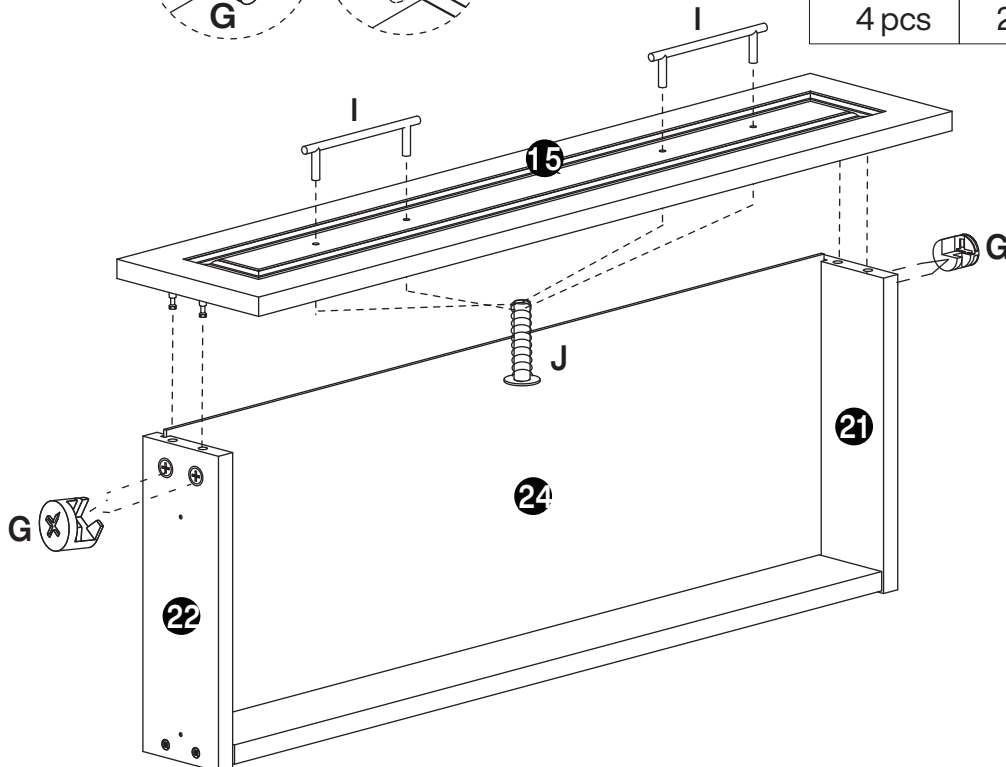

G	I	J
12mm 4 pcs	2 pcs	M4x18mm 4 pcs



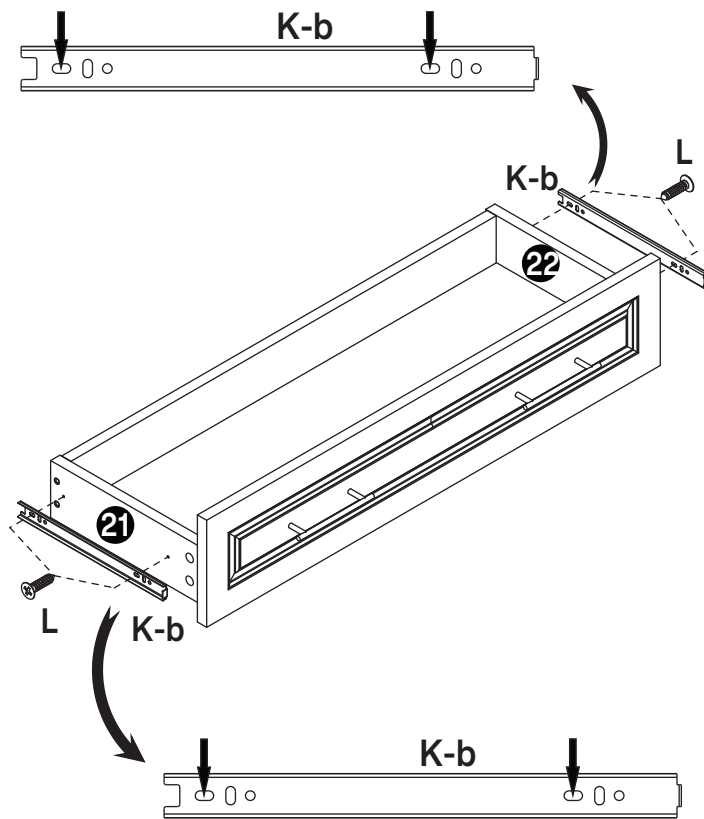

5

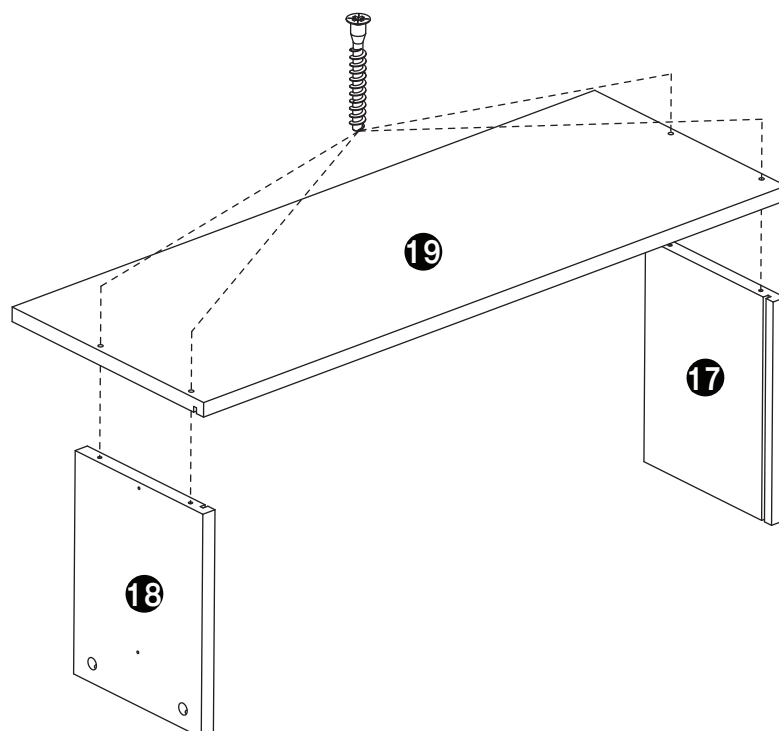

K-b	L
	 M3.5x14mm
2 pcs	4 pcs

6



C
 Ø5x38mm
4 pcs

7

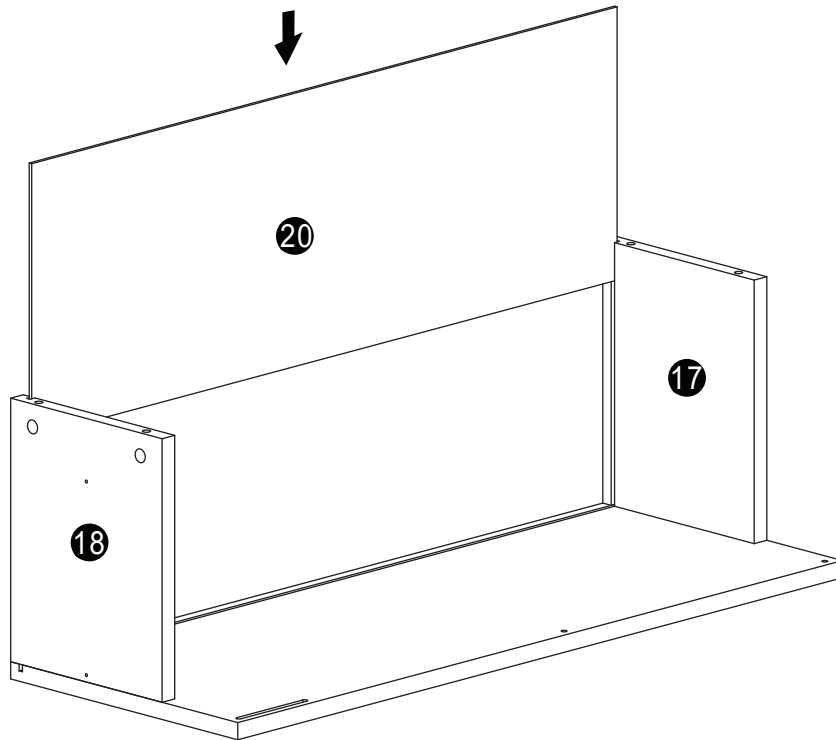

8

G	I	J	N	S
12mm		M4×18mm	Ø16×Ø6.2mm	M4×28mm
4 pcs	2 pcs	4 pcs	2 pcs	1 pc

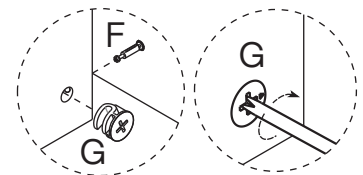
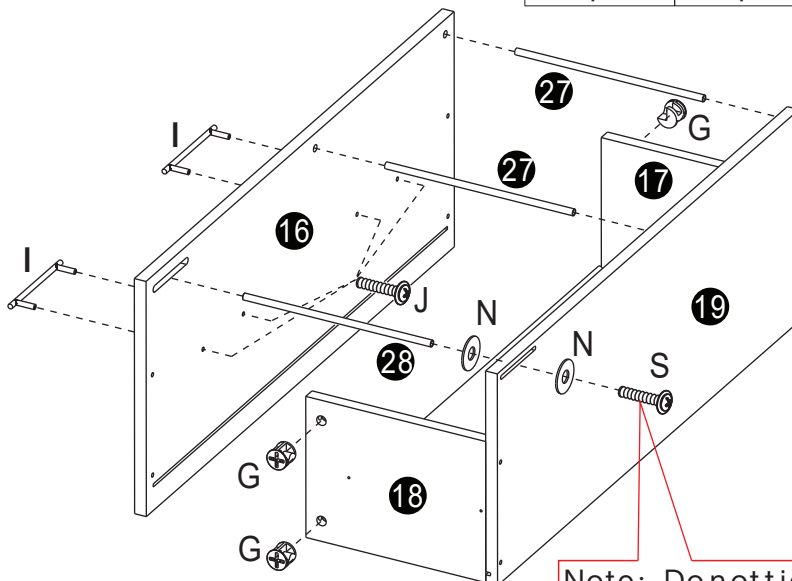

Note: Donottighten
the screws completely

9

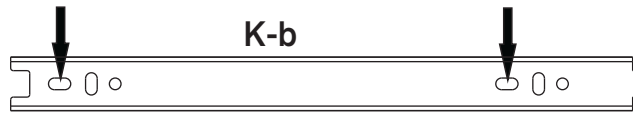

K-b	L
2 pcs	M3.5x14mm 4 pcs

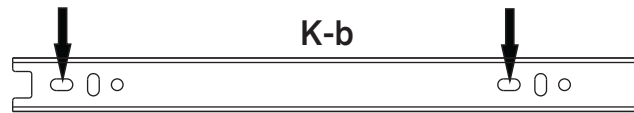
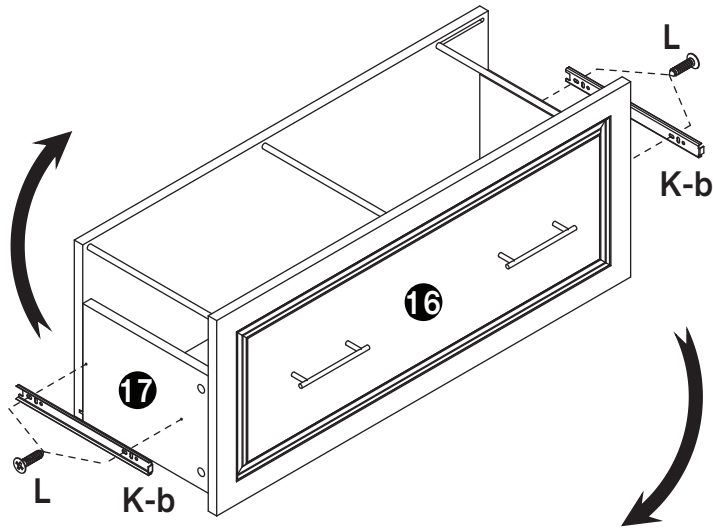

10

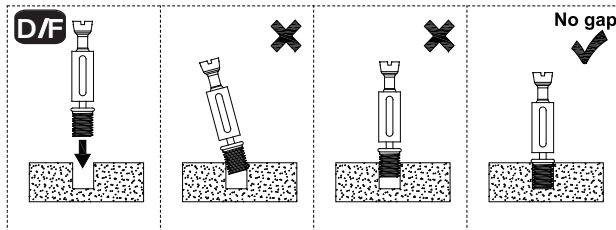

D	F	K-a	L
Ø6x44.5mm 2 pcs	Ø6x28mm 2 pcs	2 pcs	M3.5x14mm 6 pcs

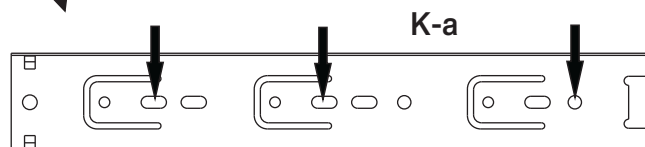
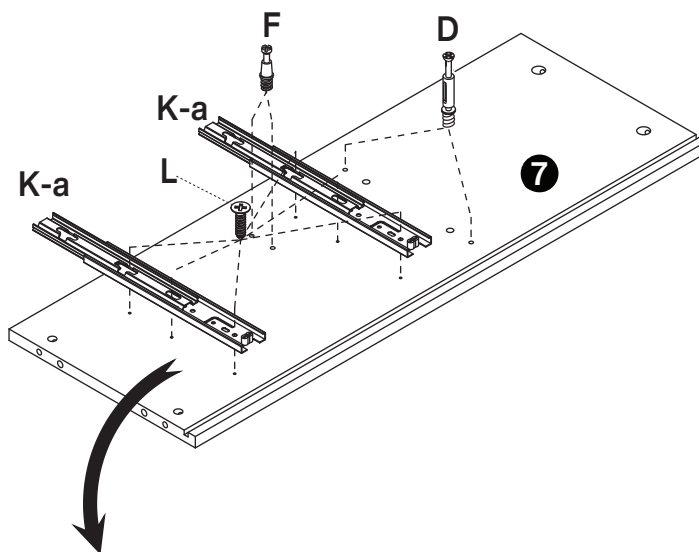

11

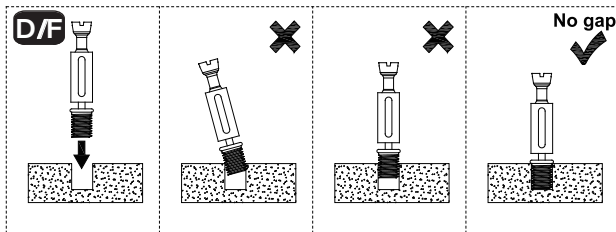

D	F	K-a	L
Ø6x44.5mm	Ø6x28mm		M3.5x14mm
2 pcs	2 pcs	2 pcs	6 pcs

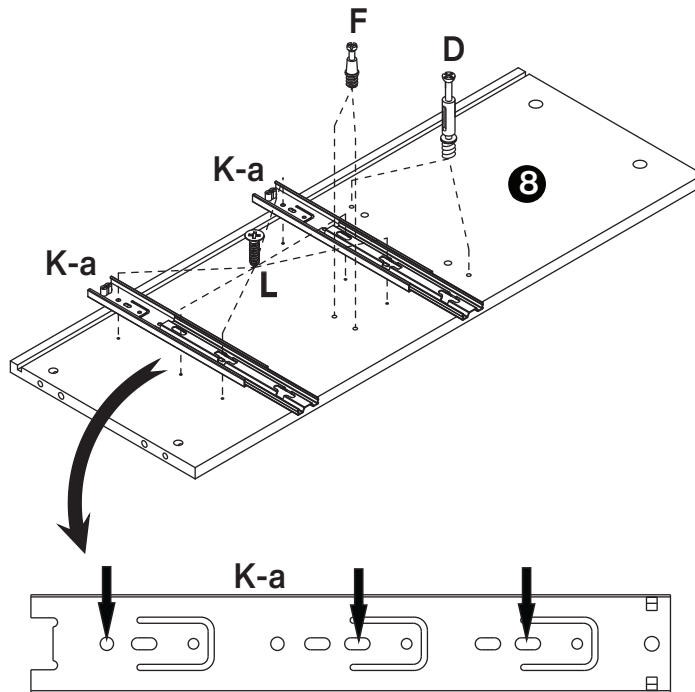

12

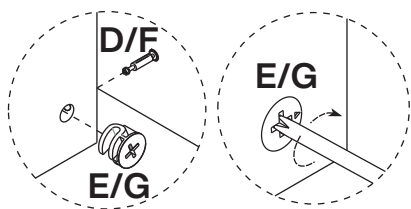

E	G	H
15mm	12mm	Ø8x30mm
4 pcs	4 pcs	4 pcs

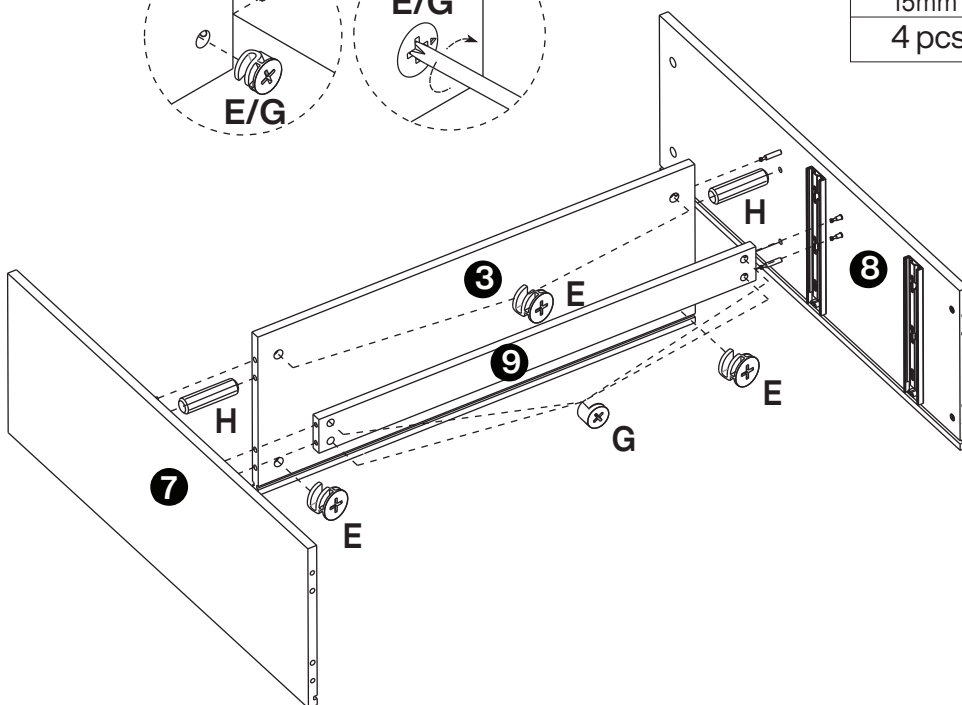

13

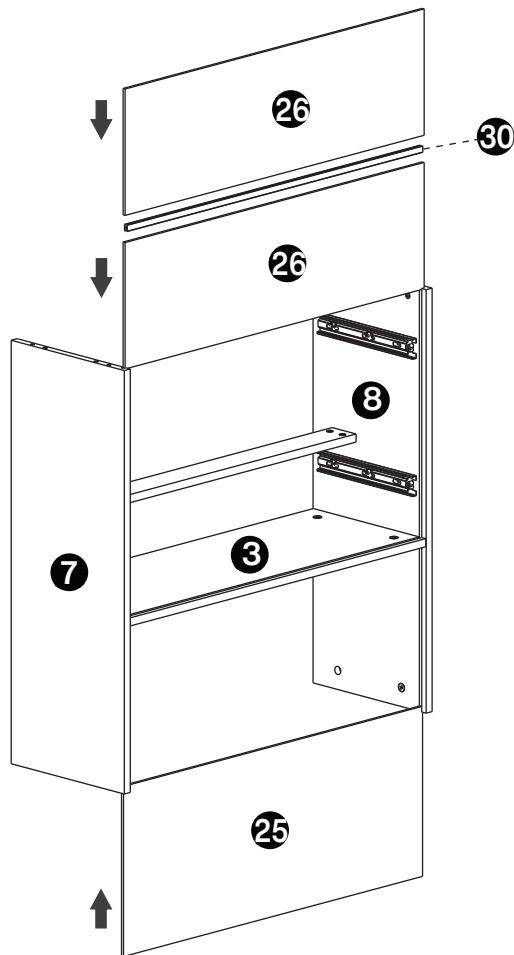

14

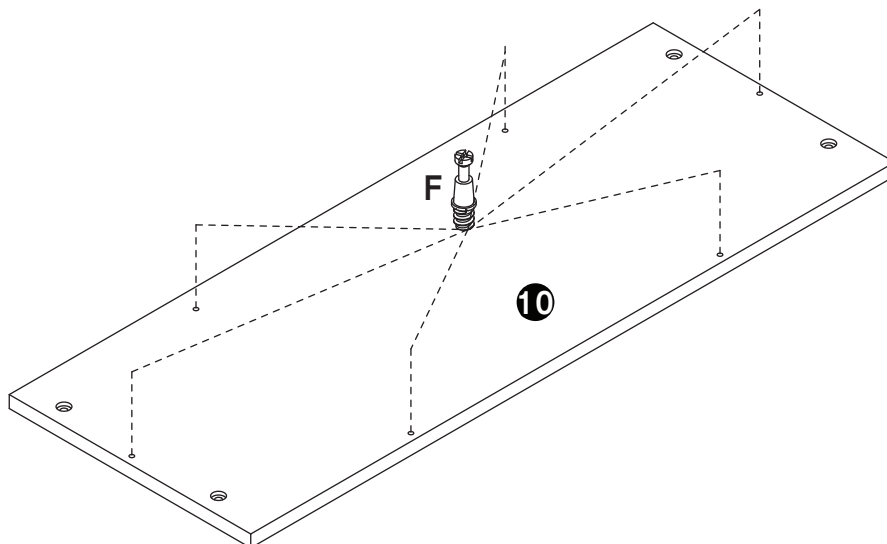
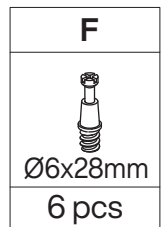
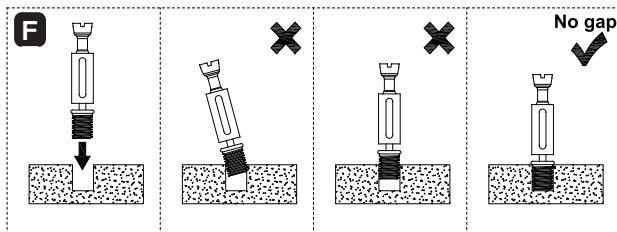

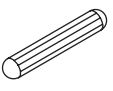

15

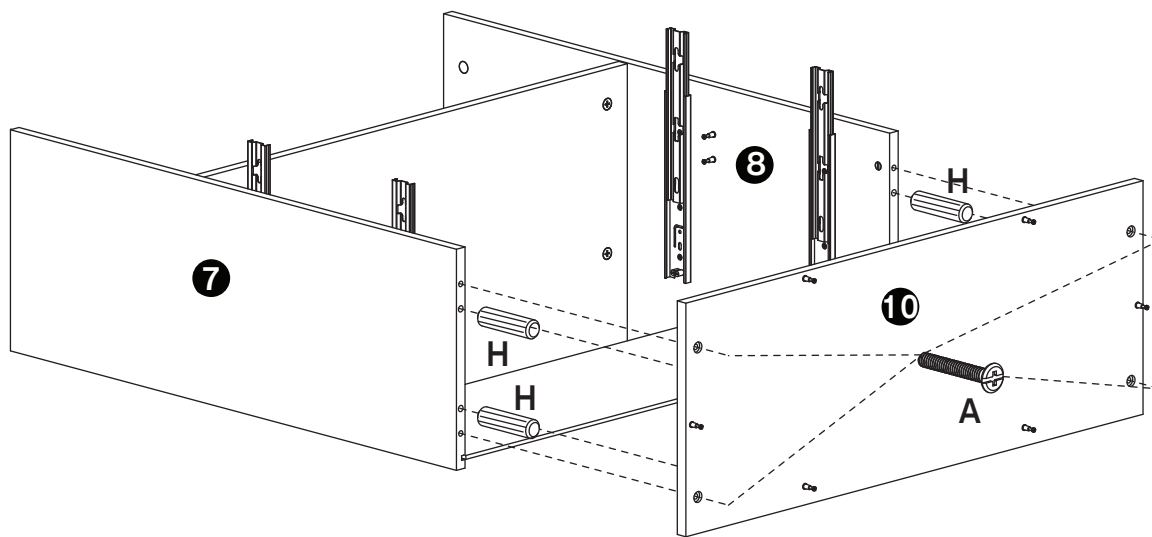
A	H
	
M6×40mm	Ø8×30mm
4 pcs	4 pcs

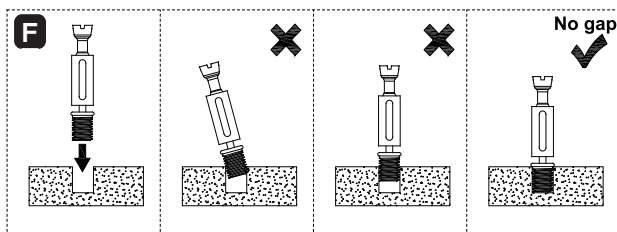

16



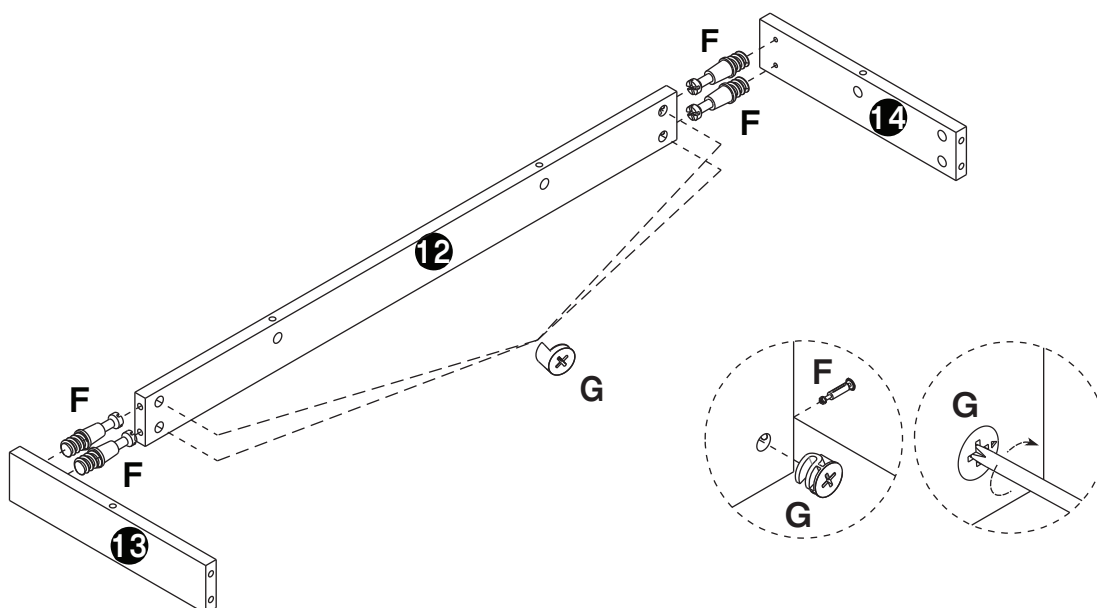

F	G
	
Ø6x28mm	12mm
4 pcs	4 pcs

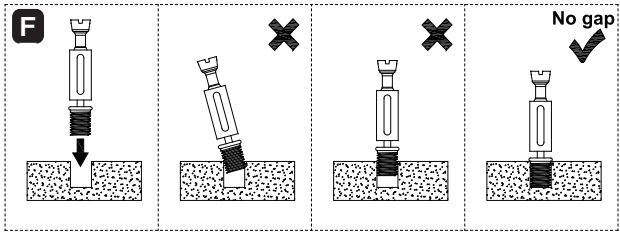

17



F	G
	
Ø6x28mm	12mm
4 pcs	4 pcs

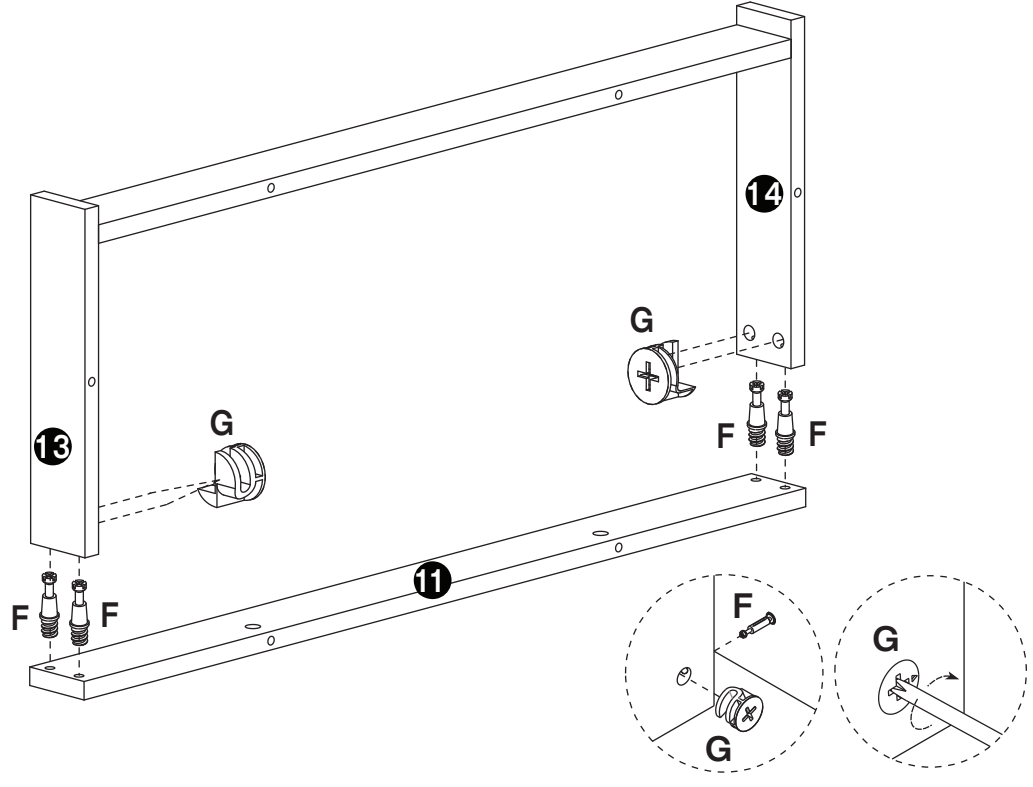

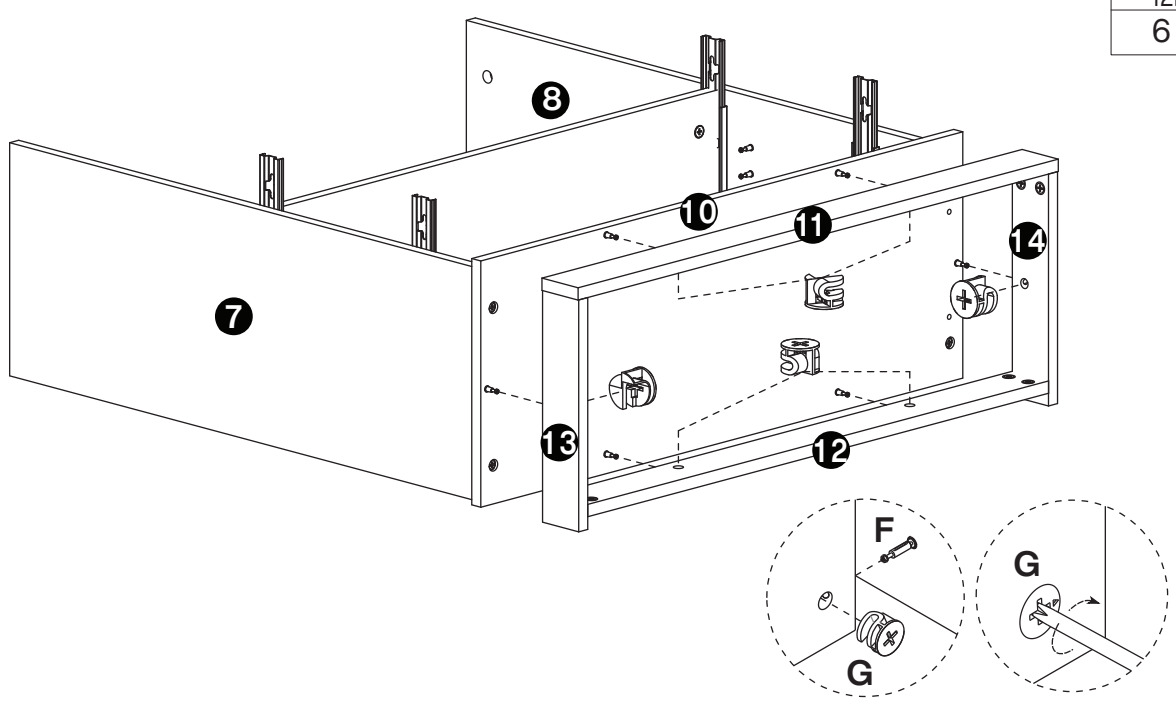

18

G

12mm
6 pcs

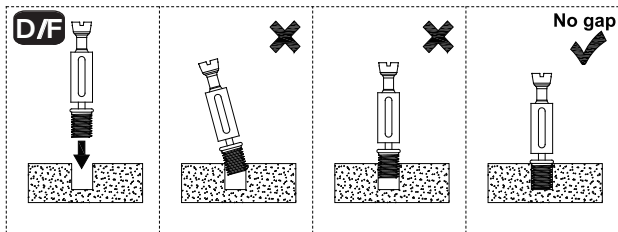

19

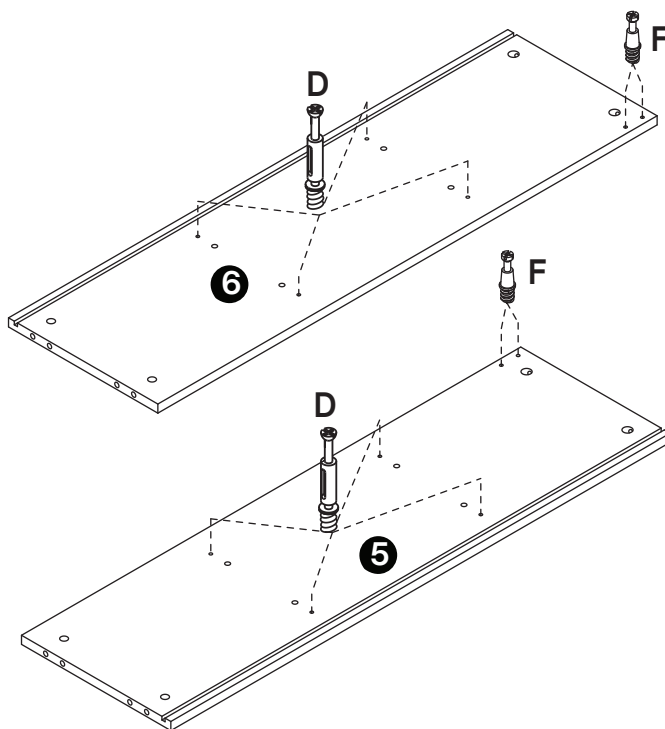

D	F
	
Ø6x44.5mm	Ø6x28mm
8 pcs	4 pcs



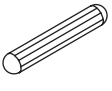

20

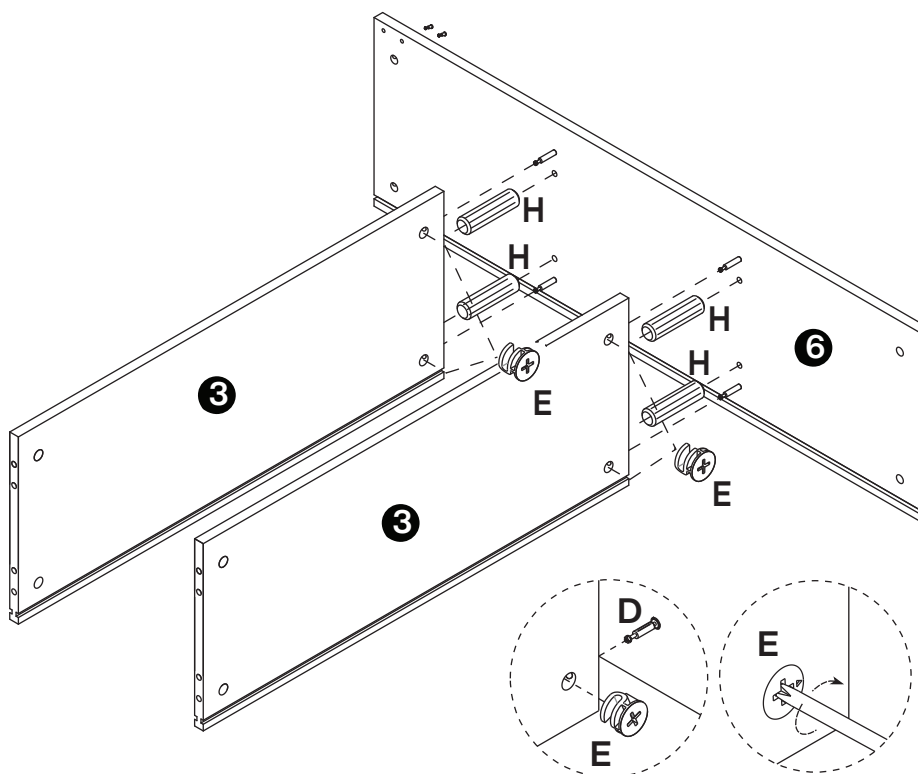
E	H
	
15mm	Ø8x30mm
4 pcs	4 pcs

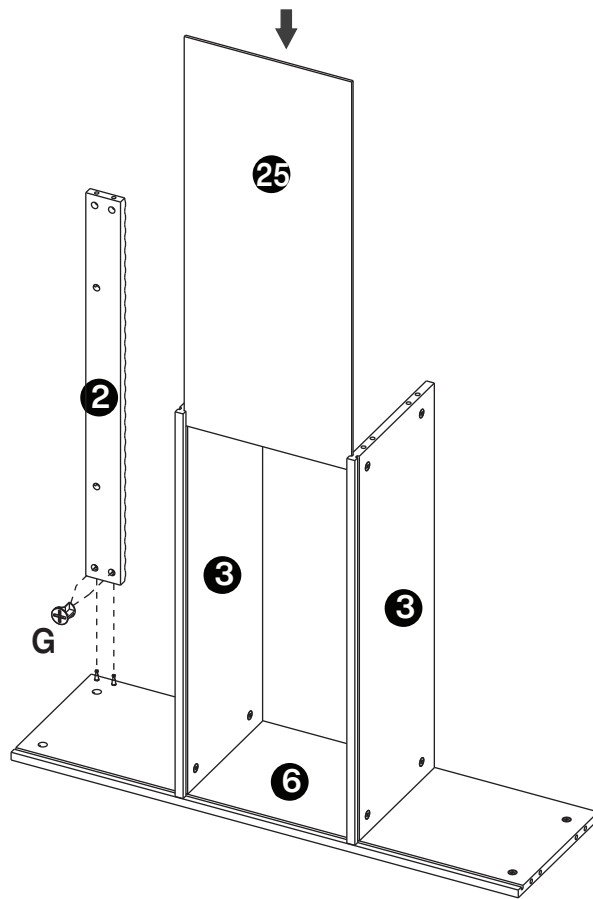

21



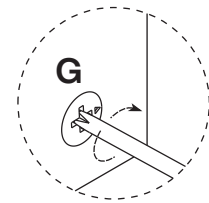
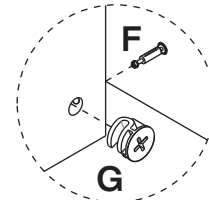

G

12mm
2 pcs

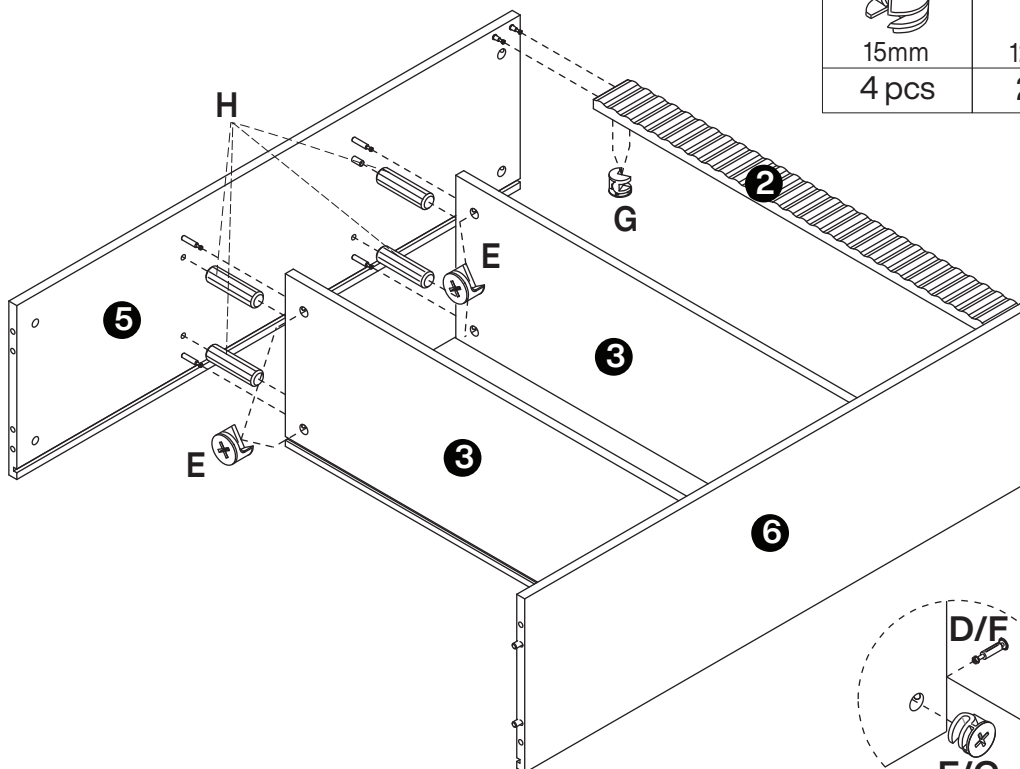

22

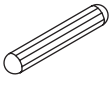

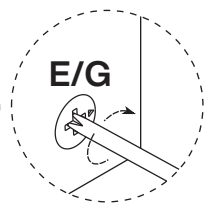
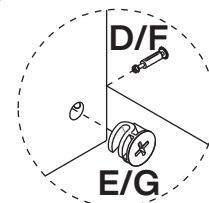
E	G	H
		
15mm	12mm	Ø8×30mm
4 pcs	2 pcs	4 pcs



23

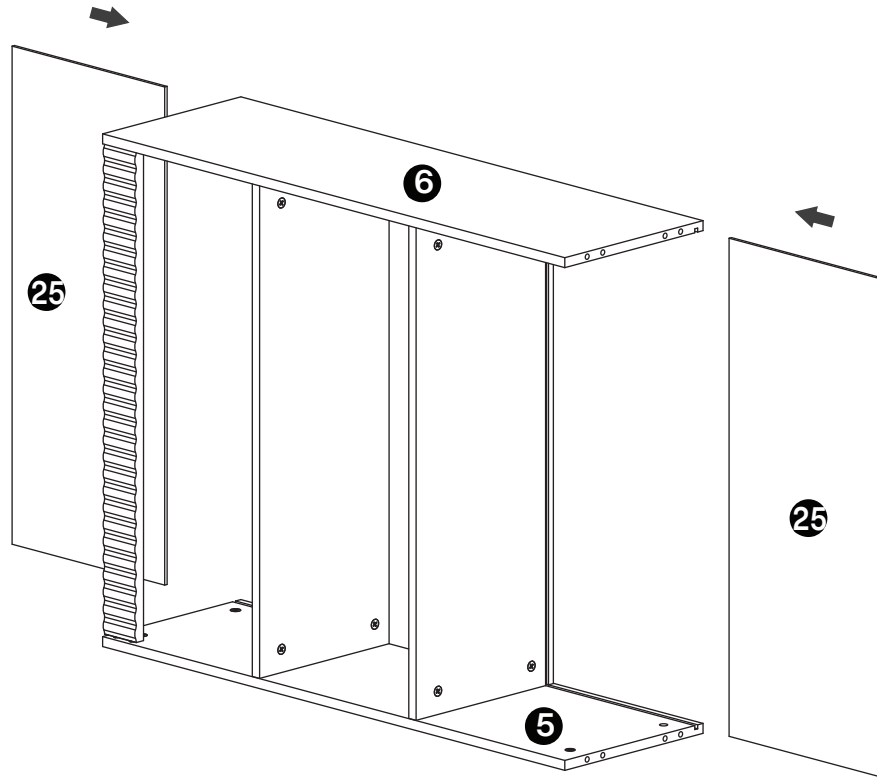

24

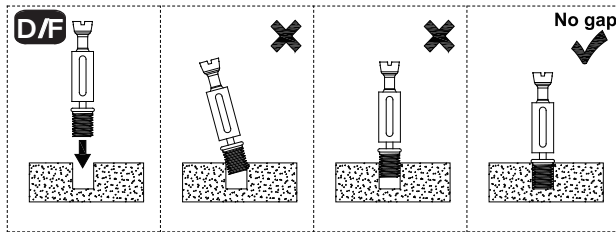

D	F
Ø6x44.5mm 12 pcs	Ø6x28mm 2 pcs

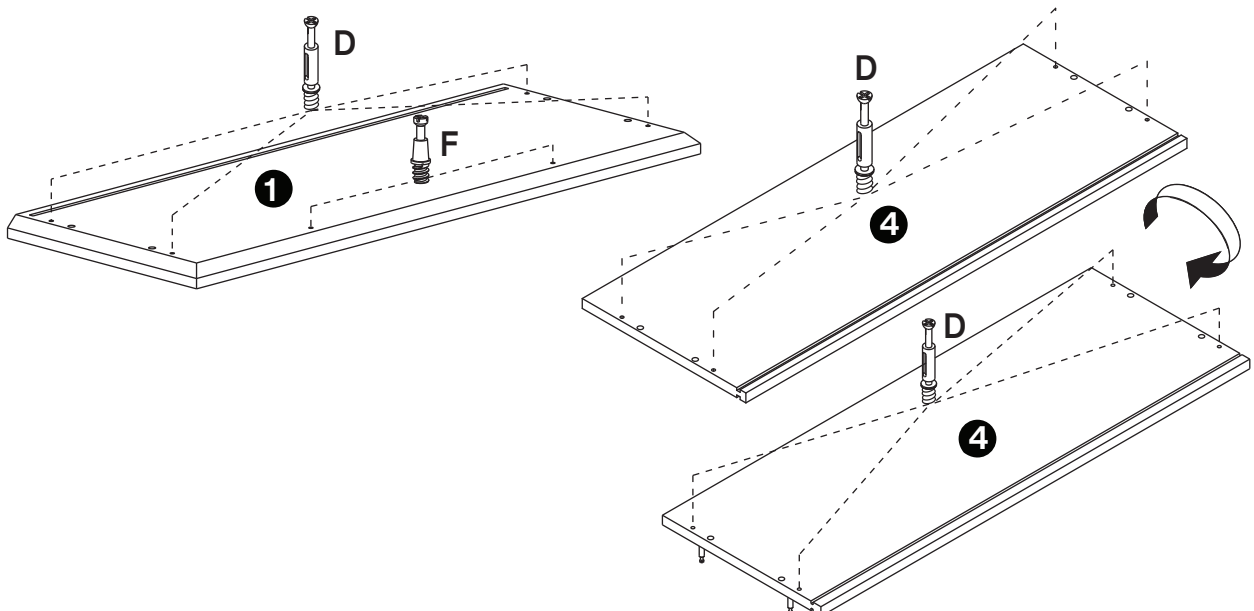

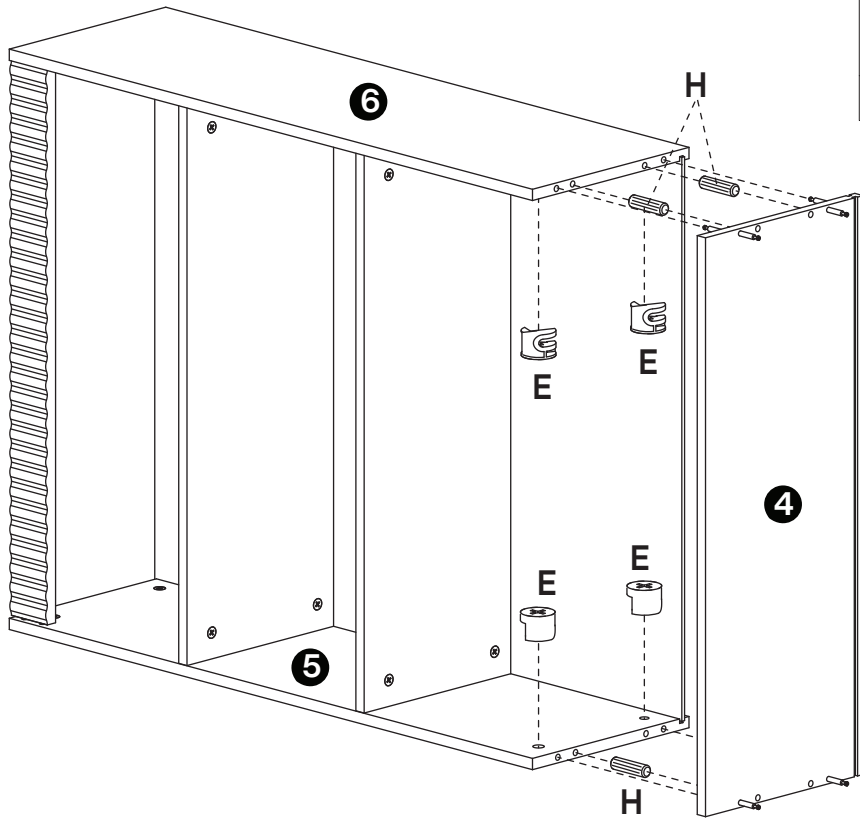

25

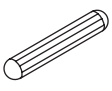

E	H
	
15mm	Ø8×30mm
4 pcs	4 pcs

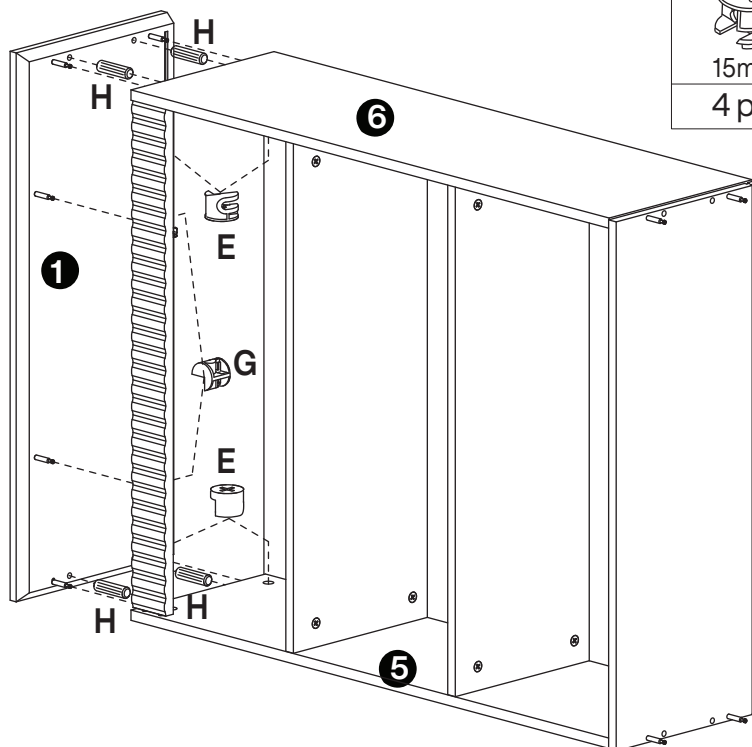

26

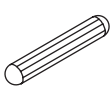

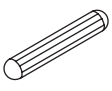

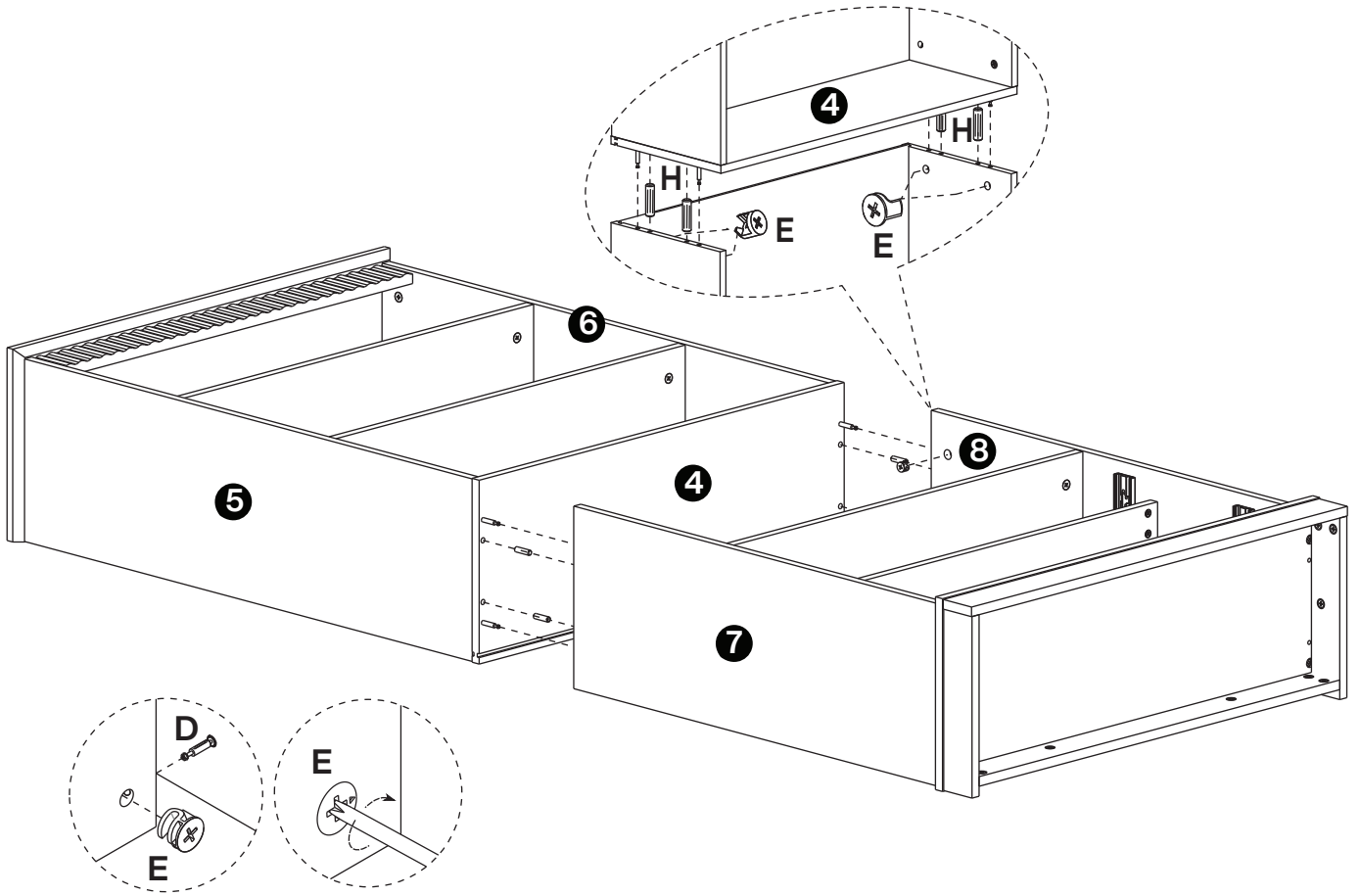
E	G	H
		
15mm	12mm	Ø8×30mm
4 pcs	2 pcs	4 pcs

E	H
	
15mm	Ø8×30mm
4 pcs	4 pcs

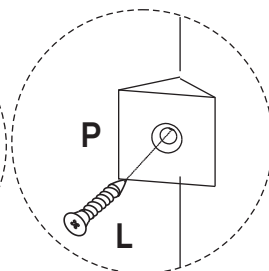
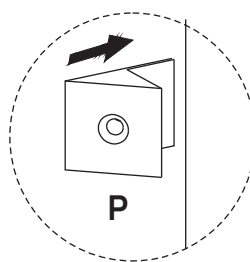
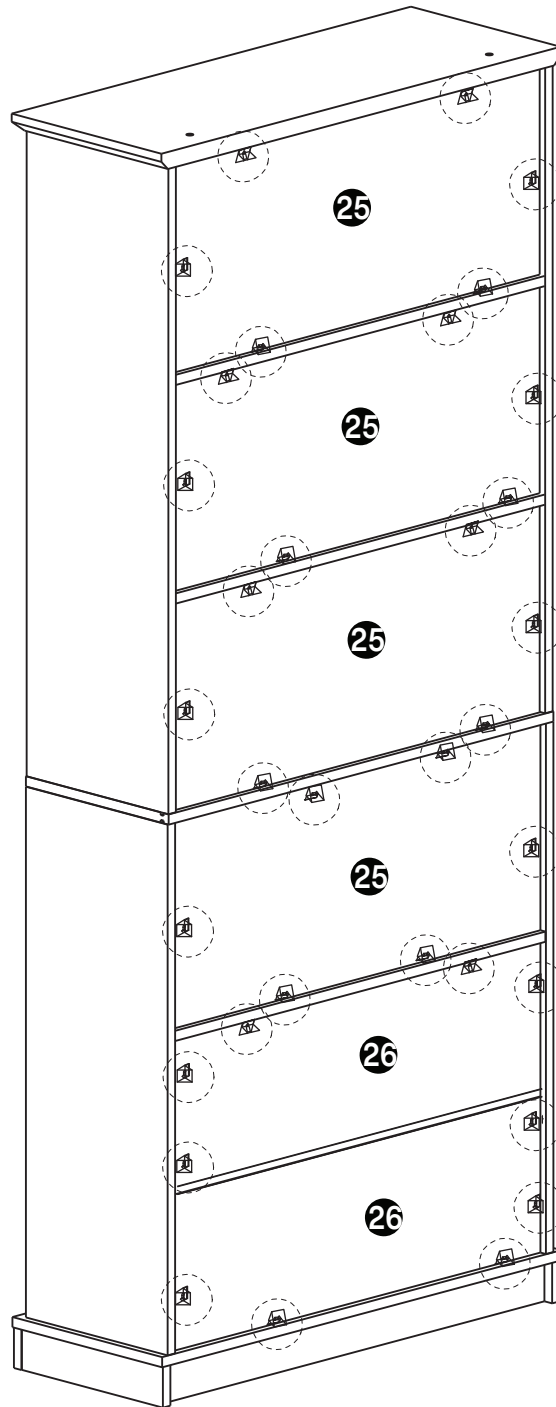

L	P
 M3.5x14mm	
34 pcs	34 pcs



Q	R
	
Ø21mm	Ø21mm
16 pcs	12 pcs

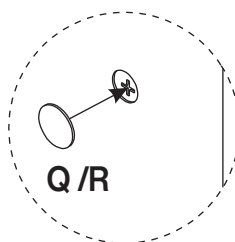
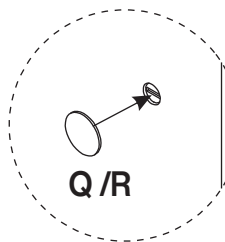
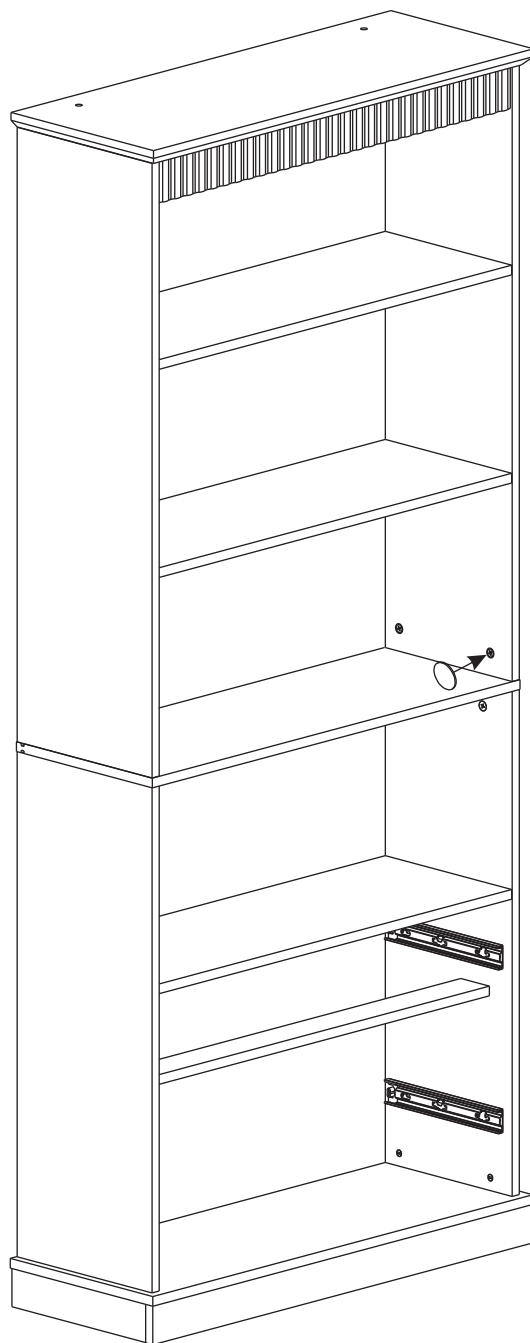

30

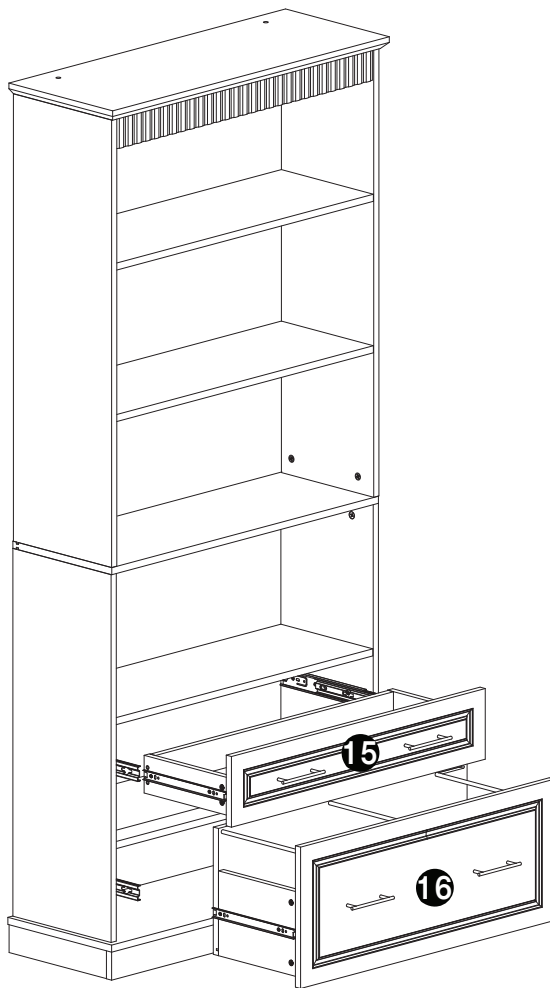

Step 1

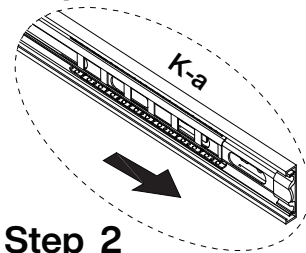

Step 2

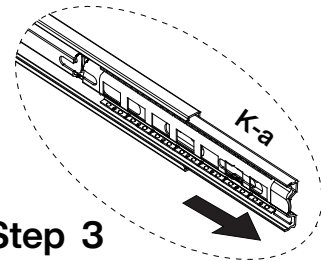

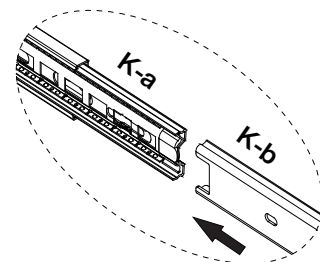

Step 3





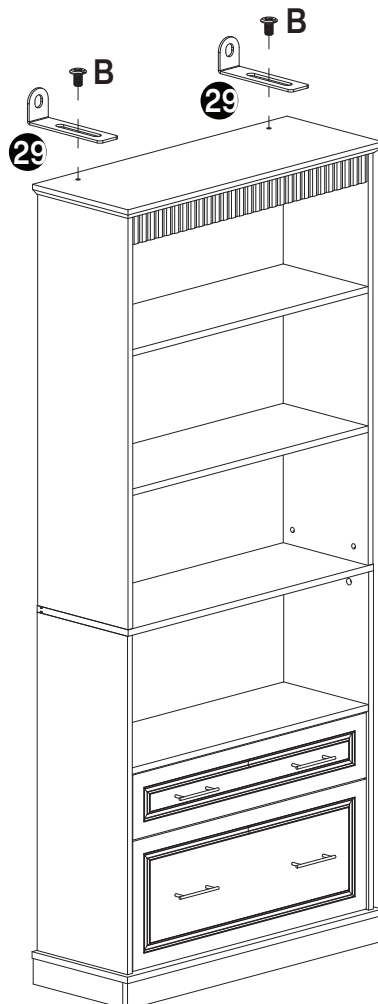

Before installation, slide the inner iron pieces of #K-a to the outermost side. Then align it with #K-b and gently push it inward to complete the slide installation.

31

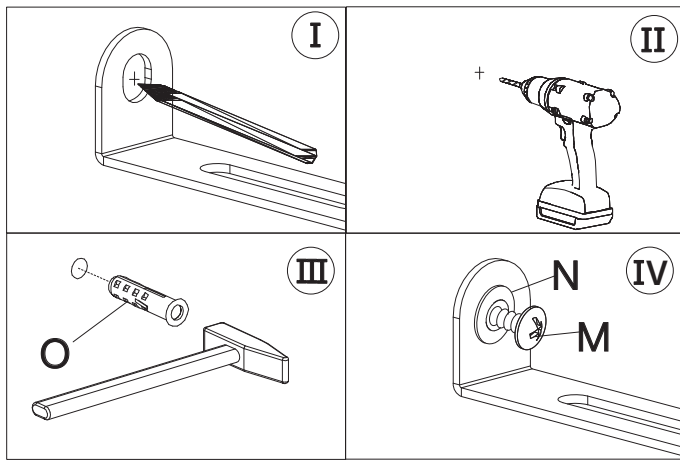

B

M6×12mm
2 pcs

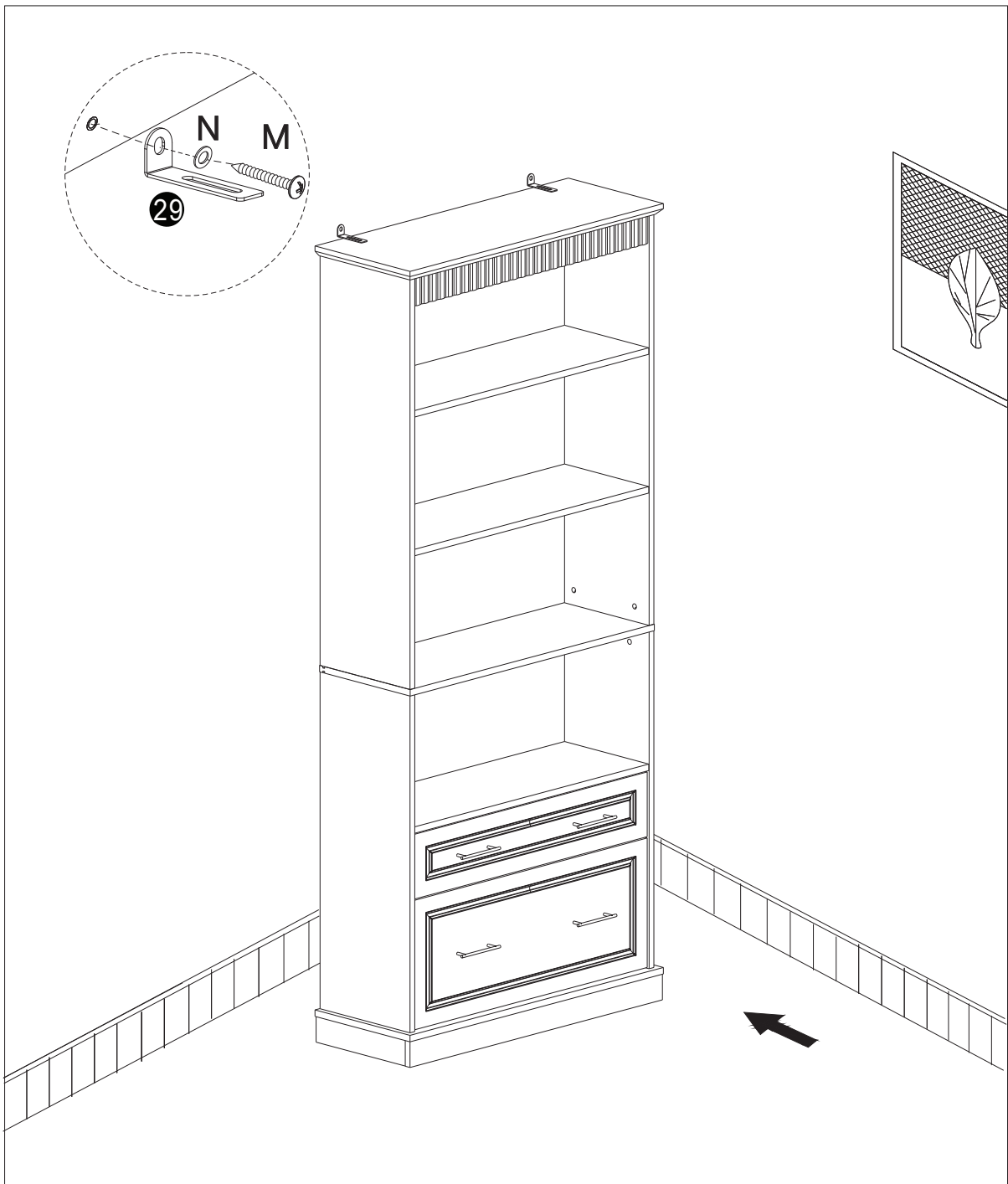

M	N	O
		
4x24.5mm	Ø16XØ6.2mm	
2 pcs	2 pcs	2 pcs



Thank you for your support!

