



**MARVEL**



**OWNER'S GUIDE & SERVICE MANUAL**

MARVEL UNDERCOUNTER REFRIGERATION

Model: MACR215-SS01B

# WELCOME

## Welcome to the Marvel Experience!

Thank you for choosing our quality American-built product to add to your home. We are thrilled to welcome you to our growing community of Marvel owners, who trust in our products and our support.

The information in this guide is intended to help you install and maintain your new Marvel undercounter model to protect and prolong its lifetime. We encourage you to contact our Technical Support team at (616) 754-5601 with any questions.

## Got a Marvelous Design?

We would love to see how your Marvel product looks in its new home. You can send us photos of your installed product at [marketing@marvelrefrigeration.com](mailto:marketing@marvelrefrigeration.com), and we might feature your Marvel home design on our website and social media!

## Warranty Registration

It is important you register your product warranty after taking delivery of your appliance. You can register online at [www.marvelrefrigeration.com](http://www.marvelrefrigeration.com).

The following information will be required when registering your appliance:

Serial Number  
Date of Purchase  
Dealer's name and address

Online registration  
available at  
[marvelrefrigeration.com](http://marvelrefrigeration.com)

The serial number can be found on the serial plate which is located inside the cabinet on the left side near the top.



# TABLE OF CONTENTS

---

**Tip:** Click on any section below to jump directly there

## Safety

Important Safety Instructions

Warranty

## Installation

Unpacking Your Appliance

Electrical

Cutout & Product Dimensions

Side-by-Side & Stacking Installations

Installing the anti-tip device

Door Reversal

Installing The Water Supply

## Maintenance

Care and Cleaning

Stainless Steel Maintenance

Extended Non-Use

## Operating Instructions

Ice Maker Operation

## Service

Obtaining Service

Wire Diagram

Product Liability

Warranty Claims

Parts List

Ordering Replacement Parts

R600a Specifications

System Diagnosis Guide

Defrost

Replace Ice Maker

# IMPORTANT SAFETY INSTRUCTIONS

---

## Important Safety Instructions

Warnings and safety instructions appearing in this guide are not meant to cover all possible conditions and situations that may occur. Common sense, caution and care must be exercised when installing, maintaining or operating this appliance.

### Recognize Safety Symbols, Words and Labels



#### WARNING

**WARNING** - You can be killed or seriously injured if you do not follow these instructions.



#### CAUTION

**CAUTION** - Hazards or unsafe practices which could result in personal injury or property/product damage.

#### NOTE

**NOTE** - Important information to help assure a problem-free installation and operation.



#### WARNING

**State of California Proposition 65 Warning:**  
This product contains one or more chemicals known to the State of California to cause birth defects or other reproductive harm.



#### WARNING

**State of California Proposition 65 Warning:**  
This product contains one or more chemicals known to the State of California to cause cancer.



#### WARNING

**WARNING** - This unit contains R600a (isobutane) which is a flammable hydrocarbon. It is safe for regular use. Do not use sharp objects to expedite defrosting. Do not damage refrigerant circuit.

# UNPACKING YOUR APPLIANCE



## WARNING

### EXCESSIVE WEIGHT HAZARD

Use two or more people to move product.  
Failure to do so can result in personal injury.



## CAUTION

If the appliance was shipped, handled or stored in other than an upright position for any period of time, allow the appliance to sit upright for a period of at least 24 hours before plugging in. This will assure oil returns to the compressor. Plugging the appliance in immediately may cause damage to internal parts.

### Remove Interior Packaging

Your appliance has been packed for shipment with all parts that could be damaged by movement securely fastened. Remove internal packing materials and any tape holding internal components in place. The getting started guide is shipped inside the product in a plastic bag along with the warranty registration card and other accessory items.

### Important

Keep your carton and packaging until your appliance has been thoroughly inspected and found to be in good condition. If there is any damage, the packaging will be needed as proof of damage in transit. Afterwards, please dispose of all items responsibly.



## WARNING

**WARNING** - Dispose of the plastic bags which can be a suffocation hazard.



## WARNING

### WARNING - Help Prevent Tragedies

Child entrapment and suffocation are not problems of the past. Junked or abandoned refrigerators are still dangerous, even if they sit outside for "just a few hours".

If you are getting rid of your old refrigerator, please follow the instructions below to help prevent accidents.

Before you throw away your old refrigerator or freezer:

- Take off the doors or remove the drawers.
- Leave the shelves in place so children may not easily climb inside.

### Note to Customer

This merchandise was carefully packed and thoroughly inspected before leaving out facility. Responsibility for its safe delivery was assumed by the retailer upon acceptance of the shipment. Claims for loss or damage sustained in transit must be made to the retailer.

## NOTE

DO NOT RETURN DAMAGED MERCHANDISE TO THE MANUFACTURER - FILE THE CLAIM WITH THE RETAILER.

# ELECTRICAL

## Electrical Connection

A grounded 115 volt, 15 amp dedicated circuit is required.

This product is factory equipped with a power supply cord that has a three-pronged, grounded plug. It must be plugged into a mating grounding type receptacle in accordance with the National Electrical Code and applicable local codes and ordinances. If the circuit does not have a grounding type receptacle, it is the responsibility and obligation of the customer to provide the proper power supply. The third-ground prong should not, under any circumstances, be cut or removed.

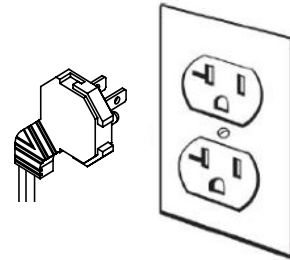
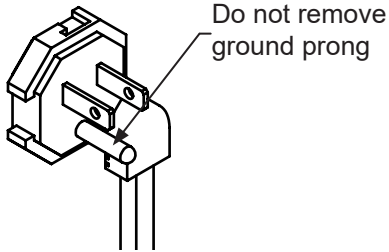

## WARNING

### Electrical Shock Hazard

- Do not use an extension cord with this appliance. They can be hazardous and can degrade product performance.
- This appliance should not, under any circumstances, be installed to an un-grounded electrical supply. Do not remove the grounding prong from the power cord.
- Do not use an adapter.
- Do not splash or spray water from a hose on the appliance. Doing so may cause an electrical shock, which may result in severe injury or death.

## NOTE

Ground Fault Circuit Interrupters (GFCI) are prone to nuisance tripping which will cause the appliance to shut down. GFCI's are generally not used on circuits with power equipment that must run unattended for long periods of time, unless required to meet local building codes and ordinances.

## CUTOUT AND PRODUCT DIMENSIONS

| ROUGH-IN OPENING DIMENSIONS |  |                | CABINET DIMENSIONS   |                                    |                    |                    |                      |                      |
|-----------------------------|--|----------------|----------------------|------------------------------------|--------------------|--------------------|----------------------|----------------------|
| "A"                         | "B"                                    | "C"            | "D"                  | "E"                                | "F"                | "G"                | "H"                  | "J"                  |
| 15"<br>(38.1 cm)            | 31 ¼" to 32 ¼"<br>(79.4 cm to 81.9 cm) | 24"<br>(61 cm) | 14 7⁄8"<br>(37.8 cm) | 31" to 32"<br>(78.7 cm to 81.2 cm) | 23 5⁄8"<br>(60 cm) | 25 ½"<br>(64.8 cm) | 37 3⁄8"<br>(94.9 cm) | 16 5⁄8"<br>(42.2 cm) |

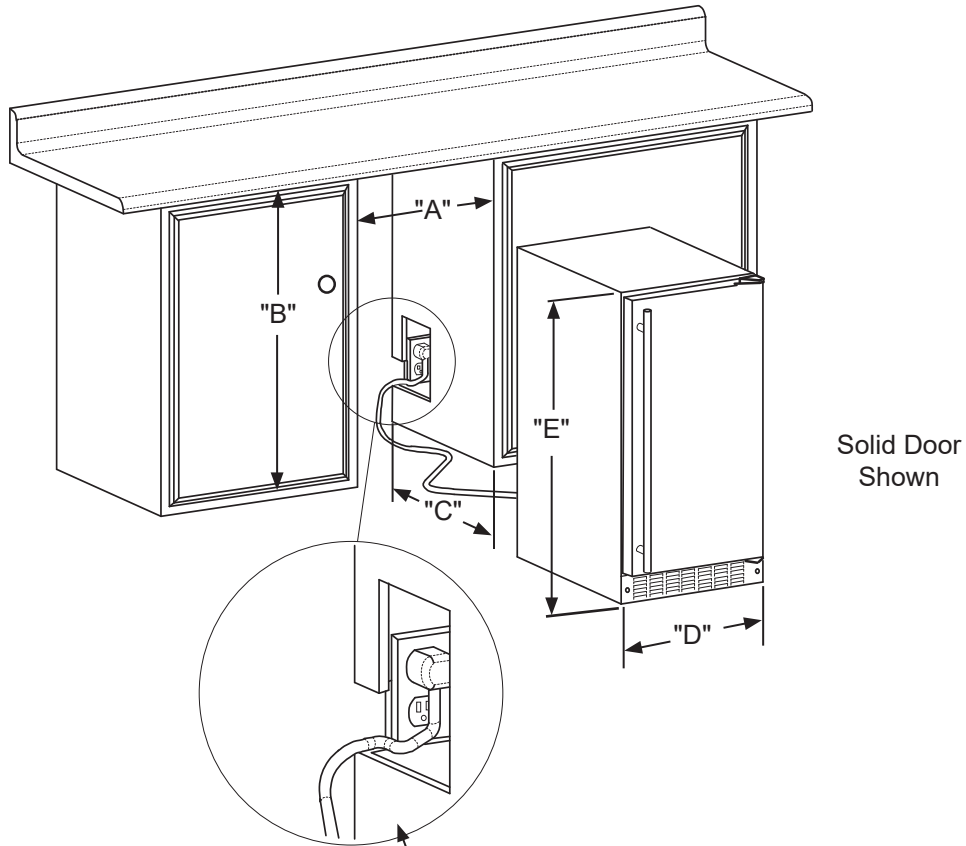

If necessary, to gain clearance inside the rough-in opening, a hole can be cut through the adjacent cabinet and the power cord routed through this hole to a power outlet. Another way to increase the available opening depth is to recess the power outlet into the rear wall to gain the thickness of the power cord plug. Not all recessed outlet boxes will work for this application as they are too narrow, but a recessed outlet box equivalent to Arlington #DVFR1W is recommended for this application.



# CUTOUT AND PRODUCT DIMENSIONS

| PRODUCT DATA              |                      |
|---------------------------|----------------------|
| ELECTRICAL REQUIREMENTS # | PRODUCT WEIGHT       |
| 115V/60Hz/15A             | 105 lbs<br>(47.6 kg) |

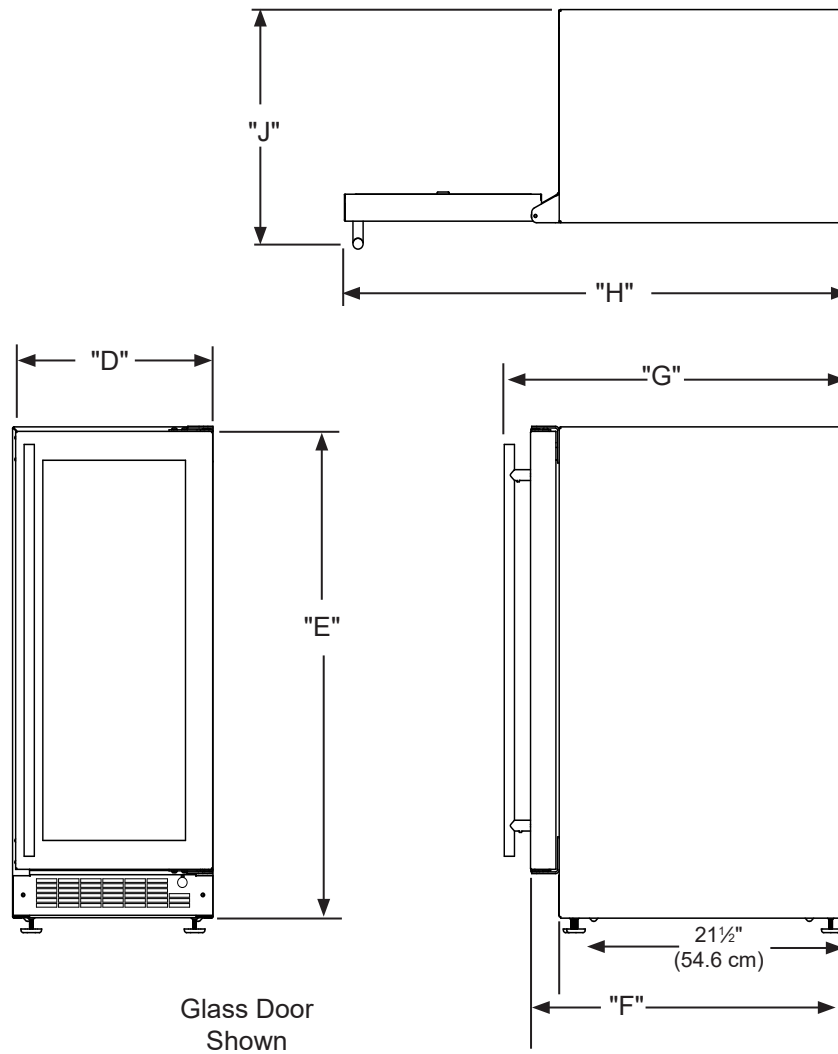

Minimum rough-in opening required is to be larger than the adjusted height of the cabinet.

A grounded 15 amp dedicated circuit is required. Follow all local building codes when installing electrical and appliance.

## Side-by-Side Installation

Two units may be installed side-by-side.

Cutout width for a side-by-side installation is the cutout dimension of a single unit times two.

No trim kit is required. However, 1/4" (6 mm) of space needs to be maintained between the units to ensure unobstructed door swing.

Units must operate from separate, properly grounded electrical receptacles placed according to each unit's electrical specifications requirements.

### Side-by-Side Installation with Bracket

1. Slide both units out so screws on top of units are easily accessible.
2. Remove screws as shown below.

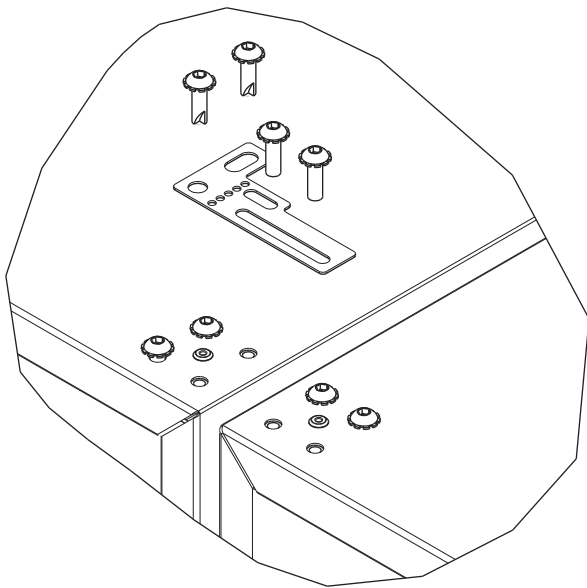

3. Place bracket over holes and attach to unit with two screws removed in step 2 using a T-25 Torx driver. Tighten screws fully.
4. Gently push units into position. Be careful not to entangle the electrical cord or water line, if applicable.
5. Re-check the leveling, from front to back and side to side. Make any necessary adjustments. The unit's top surface should be approximately 1/8" (3 mm) below the countertop.

# INSTALLING THE ANTI-TIP DEVICE

---

## Anti-Tip Bracket

1. Slide unit out so screws on top of unit are easily accessible.
2. Remove the two screws from the opposite side of the hinge assembly using a T-25 Torx driver (see below).

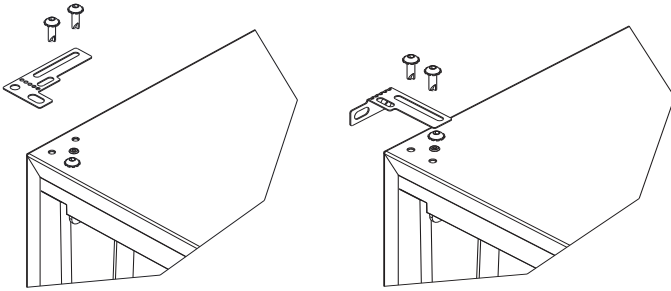

3. Place bracket over holes and attach to unit with two screws removed in step 2 using a T-25 Torx driver. Tighten screws fully.
4. Gently push unit into position. Be careful not to entangle the electrical cord or water line, if applicable.
5. Check to be sure the unit is level from front to back and side to side. Make any necessary adjustments. The unit's top surface should be approximately  $\frac{1}{8}$ " (3 mm) below the countertop.
6. Secure bracket into adjoining surface.

# DOOR REVERSAL

## Door Adjustments

### Hinge Cover

Hinge cover included with the literature bag is optional.

#### To install hinge cover:

1. Press hinge cover squarely over hinge.

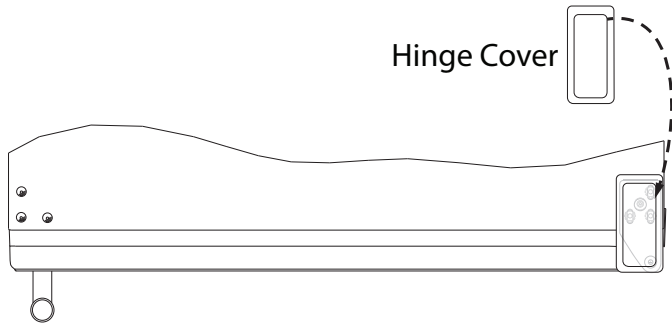

## Door Alignment and Adjustment

Align and adjust the door if it is not level or is not sealing properly. If the door is not sealed, the unit may not cool properly, or excessive frost may form in the interior.

### NOTE

Properly aligned, the door's gasket should be firmly in contact with the cabinet all the way around the door (no gaps). Carefully examine the door's gasket to ensure that it is firmly in contact with the cabinet. Also make sure the door gasket is not pinched on the hinge side of the door.

To align and adjust the door:

1. Gently pry off hinge cover from top of unit.
2. Loosen (do not remove) top and bottom hinge screws using a Torx T-25 screwdriver on the top and a 1/4" socket on the bottom.
3. Align door squarely with cabinet.
4. Make sure gasket is firmly in contact with cabinet all the way around the door (no gaps).
5. Tighten bottom hinge screws.
6. Tighten top hinge screws and replace hinge cover.

## Reversing the Door

Location of the unit may make it desirable to mount the door on the opposite side of the cabinet.

The hinge hardware will be removed and reinstalled on the opposite side of the cabinet.

## To Reverse the Door

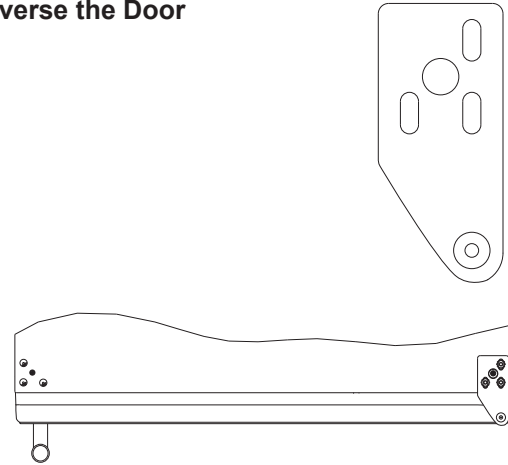

### Remove arrow clips:

1. With a putty knife or other flat tool, gently pry each arrow clip from hinge mounting holes.
2. Set aside arrow clips to be reused on the opposite side.

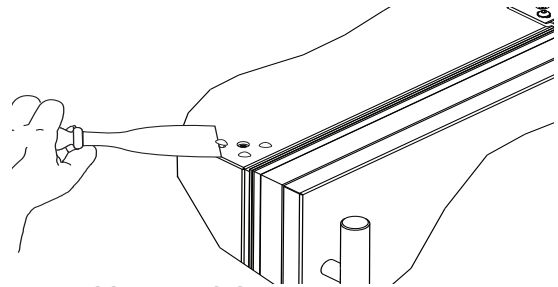

### Remove top hinge and door:

1. Remove hinge cover from top of unit
2. Hold door to keep it from falling.
3. Remove top hinge from cabinet using a Torx T-25 screwdriver to remove three screws.

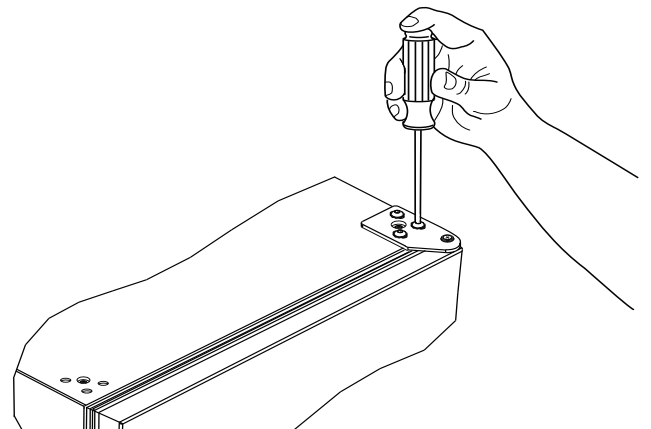

# DOOR REVERSAL

1. Remove door by tilting forward and lifting door off bottom hinge. Retain shoulder washers; they will be reused.
2. Insert arrow clips into holes

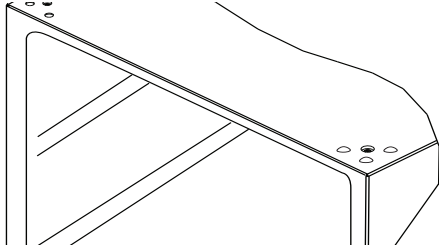

## Remove bottom hinge:

1. Remove bottom hinge from cabinet using a 1/4" socket.

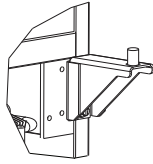

2. Remove corresponding screws on opposite side of cabinet. On some models there may be a nut behind one or both screws on either side.

## Install bottom hinge:

Install two or three screws, depending on model. Replace nuts if used.

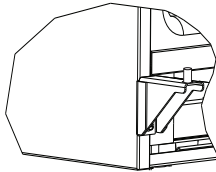

## Prepare Door for Reinstallation

### Rotate gasket

1. With a flat tool, such as a putty knife, gently pry up beneath the gasket and spacer until completely free from the door surface.
2. Continue removing the gasket by grabbing hold and gently pulling outward, exposing the gasket channel.
3. Remove the 3 pieces of gasket channel filler and reinstall on the opposite end of door.

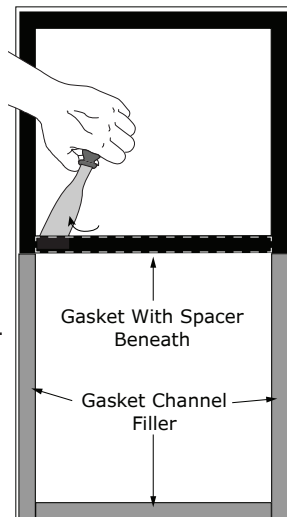

1. Install gasket into channel, beginning at one corner and pressing in firmly.
2. Press down on middle horizontal portion of gasket until it adheres to the door surface.

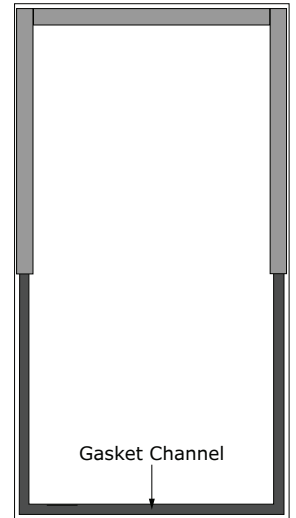
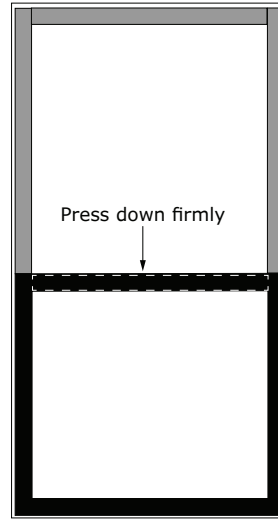

## Install top hinge and door:

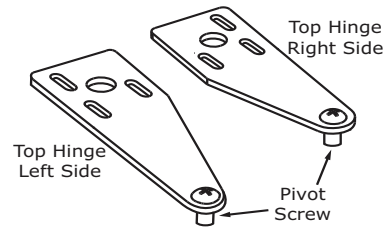

1. Remove pivot screw from hinge, flip hinge over, and install the pivot screw in the same hole from the opposite surface.
2. Lift the door onto the bottom hinge.
3. Align edge of the hinge with the outer edge of the unit.
4. Tighten three screws and replace hinge cover.
5. Replace hinge cover.

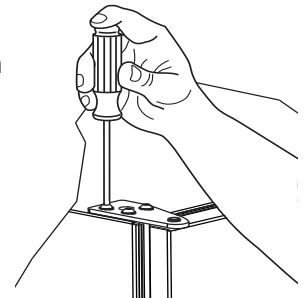

## Align and adjust the door:

Align and adjust the door (see Door Alignment and Adjustment)

# INSTALLING THE WATER SUPPLY

---

## Prepare Plumbing

### CAUTION

Plumbing installation must observe all state and local codes. All water and drain connections **MUST BE** made by a licensed/qualified plumbing contractor. Failure to follow recommendations and instructions may result in damage and/or harm.

## Water Supply Connection

When connecting the water supply, please note the following:

- Before installing the unit and connecting to the cold water supply, review the local plumbing codes.
- The water pressure should be between a minimum of 20 and a maximum of 120 psi (138 and 827 kPa).
- Water has less than 400 mg/L (ppm) total dissolved solids and hardness level below 200 mg/L (ppm) — i.e., below 12 grains per gallon. Check by using TDS meter or consulting with local water company.
- TDS and/or water hardness above these limits should be treated with a reverse osmosis system or other filtration system.
- Softened water is not recommended as it may result in softer ice than desired.
- Connection to the water main is made with hose-set only.
- Hose-set must be new, not reused, and in compliance with IEC 61770.
- The water line **MUST** have a shut-off valve in the supply line.
- The water line should be looped into 2 coils. This will allow the unit to be removed for cleaning and servicing. Make certain that the tubing is not pinched or damaged during installation.

### CAUTION

Do not use any plastic water supply line. The line is under pressure at all times. Plastic may crack or rupture with age and cause damage to your home. Do not use tape or joint compound when attaching a braided flexible water supply line that includes a rubber gasket. The gasket provides an adequate seal – other materials could cause blockage of the valve. Failure to follow recommendations and instructions may result in damage and/or harm, flooding or void the product warranty. Use new hose set. Do not reuse old hose set.

### CAUTION

Turn off water supply and disconnect electrical supply to unit prior to installation. Use caution when handling back panel. The edges could be sharp.

## INSTALLING THE WATER SUPPLY

---

1. Turn off water supply and disconnect electrical supply to product prior to attempting installation.
2. Remove the back panel.
3. Thread water line through back panel hole (with bushing).
4. Locate water valve inlet and connect to valve.

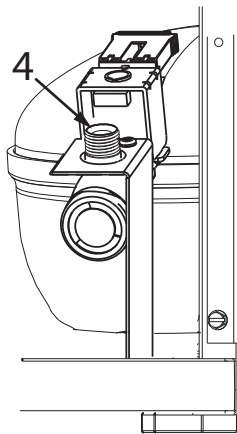
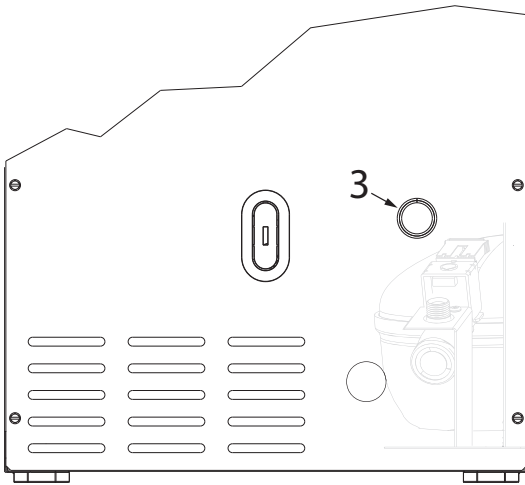

5. Turn on water supply and check for leaks.
6. Reinstall back panel.

# ICE MAKER OPERATION

## Ice Maker Operation

When the ice bucket is full, the ice making mechanism will shut off. However, the refrigeration system will continue to cool and maintain the ice supply.

### NOTE

Do not place cans or bottles in the ice compartment because they will freeze.

### To turn off ice production:

Raise the bin arm into an upright and locked position. The unit will preserve temperature for ice storage.

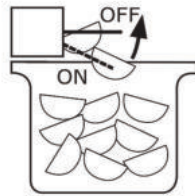

### NOTE

If not intending to use the ice maker, turn the water supply valve off. It is also important to raise the bin arm of the ice maker (see above). Failure to raise the bin arm may result in damage to the water valve.

Certain sounds are normal during the unit's operation. You may hear the compressor or fan motor, the water valve, or ice dropping into the ice bucket.

### CAUTION

NEVER use an ice pick, knife or other sharp instrument to separate cubes. Shake the ice bucket instead.

During periods of limited use or high ambient temperatures, it is common for cubes to fuse together. Gently shake the bucket to break apart cubes. If not using the ice maker regularly, empty the ice bucket periodically to ensure fresh cubes. It is normal for cubes to appear cloudy. The cause is air trapped in the water because of fast freezing. It is not caused by the health, taste or chemical make up of the water. It is the same air that is in every glass of water you drink. Remove the ice bucket for emptying and cleaning. To remove the ice bucket, raise the bin arm and remove the bucket from the ice compartment. Use the ice bucket for ice storage only.

## Ice Cube Thickness Adjustment

Interval - As Required.

On ice maker equipped models, adjust the cube size by changing water amount injected into the ice maker assembly as follows:

1. Remove the ice maker assembly cover (1).
2. Find the adjusting screw on the ice maker assembly control box (2). The adjusting screw is just below the minus (-) and plus (+) signs on the control box.

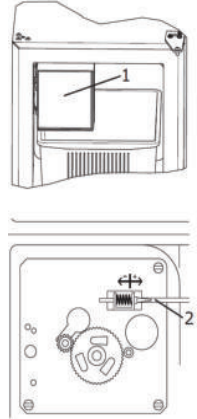

### CAUTION

Too large of an adjustment to the screw can cause the water to overflow the ice maker and can cause property damage.

3. Turn the adjusting screw toward the minus (-) sign (clockwise) for smaller cubes or toward the plus (+) sign (counterclockwise) for larger cubes.
4. Install the ice maker assembly cover.

## Adjusting Ice Harvest

1. Remove the front grille.
2. Using a flat tip screwdriver, turn the adjusting screw (3) a small increment clockwise for a COLDER setting (slower ice production) or counterclockwise for a WARMER setting (faster ice production).
3. Reinstall the front grille (two screws).

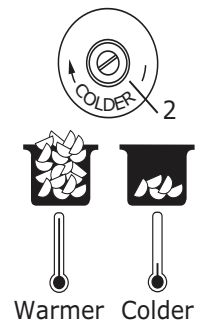

# CARE AND CLEANING

---

## Exterior Cleaning

Stainless door panels, handles and frames can discolor when exposed to chlorine gas, pool chemicals, saltwater or cleaners with bleach.

Keep your stainless unit looking new by cleaning with a good quality all-in-one stainless steel cleaner and polish monthly. For best results use Claire® Stainless Steel Polish and Cleaner. Comparable products are acceptable. Frequent cleaning will remove surface contamination that could lead to rust. Some installations may require cleaning weekly.

Do not clean with steel wool pads.

Do not use stainless steel cleaners or polishes on any glass surfaces.

Clean any glass surfaces with a non-chlorine glass cleaner.

Do not use cleaners not specifically intended for stainless steel on stainless steel surfaces (this includes glass, tile, and counter cleaners).

If any surface discoloring or rusting appears, clean it quickly with Bon-Ami® or Barkeepers Friend Cleanser® and a nonabrasive cloth. Always clean with the grain. Always finish with Claire® Stainless Steel Polish and Cleaner or comparable product to prevent further problems.

Using abrasive pads such as ScotchBrite™ will cause the graining in the stainless steel to become blurred.

Rust not cleaned up promptly can penetrate the surface of the stainless steel and complete removal of the rust may not be possible.

## Integrated Models

To clean integrated panels, use household cleaner per the cabinet manufacturer's recommendations.

## Interior Cleaning

Disconnect power to the unit.

Clean the interior and all removed components using a mild nonabrasive detergent and warm solution applied with a soft sponge or non-abrasive cloth.

Rinse the interior using a soft sponge and clean water.

Do not use any solvent-based or abrasive cleaners. These types of cleaners may transfer taste and/or odor to the interior products and damage or discolor the interior.

## Defrosting

This unit is a manual defrost model and will require occasional defrosting. When there is build-up of 1/4" (6 mm) or more of frost, manually defrost the unit.



DO NOT use an ice pick or other sharp instrument to help speed up defrosting. These instruments can puncture the inner lining or damage the cooling unit. DO NOT use any type of heater to defrost. Using a heater to speed up defrosting can cause personal injury and damage to the inner lining.

## CARE AND CLEANING

### To Defrost:

1. Disconnect power to the unit.
2. Remove ice bucket and discard ice.
3. Place towel or other absorbent material on bottom of ice bin.
4. Fill the ice bucket half full with warm, not hot water. This will help the unit defrost faster.
5. Place the ice bucket back into the unit on top of the towel or other absorbent material.
6. Prop the door in an open position (2 in. [50 mm] minimum).
7. After about 1 hour remove the ice bin and discard water.
8. Allow the frost to melt naturally.
9. After the frost melts completely clean the interior and all removed components. (See Interior Cleaning).

### NOTE

DO NOT clean ice bucket using a dishwasher. The bucket is not dishwasher safe and will be damaged.

10. When the interior is dry, reconnect power and turn unit on.

### NOTE

To safeguard against contaminants in ice, discard first three batches of ice after defrosting.

### Cleaning Condenser

Interval - every six months

To maintain operational efficiency, keep the front grille free of dust and lint, and clean the condenser when necessary. Depending on environmental conditions, more or less frequent cleaning may be necessary.



### WARNING

**WARNING**-Disconnect electric power to the unit before cleaning the condenser.

### NOTE

DO NOT use any type of cleaner on the condenser unit. Condenser may be cleaned using a vacuum, soft brush, or compressed air.

1. Remove the grille.
2. Clean the condenser coil using a soft brush or vacuum cleaner.
3. Install the grille.

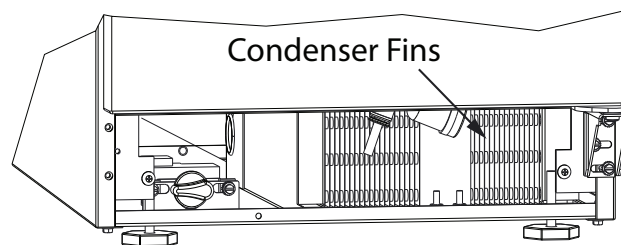

# STAINLESS STEEL MAINTENANCE

---

## Background

Stainless steel does not stain, corrode, or rust as easily as ordinary steel, but it is not stain or corrosion proof. Stainless steels can discolor or corrode if not maintained properly.

Stainless steels differ from ordinary carbon steels by the amount of chromium present. It is this chromium that provides an invisible protective film on the surface called chrome-oxide. This protective chrome-oxide film on the surface can be damaged or contaminated, which may result in discoloration, staining, or corrosion of the base metal.

## Care & Cleaning

Routine cleaning of the stainless steel surfaces will serve to greatly extend the life of your product by removing contaminants. This is especially important in coastal areas which can expose the stainless to severe contaminants such as halide salts, (sodium chloride).

It is strongly recommended to periodically inspect and thoroughly clean crevices, weld points, under gaskets, rivets, bolt heads, and any locations where small amounts of liquid could collect, become stagnant, and concentrate contaminants. Additionally, any mounting hardware that is showing signs of corrosion should be replaced.

Frequency of cleaning will depend upon the installation location, environmental, and usage conditions.

## Choosing a Cleaning Product

The choice of a proper cleaning product is ultimately that of the consumer, and there are many products from which to choose. Depending upon the type of cleaning and the degree of contamination, some products are better than others.

Typically the most effective and efficient means for routine cleaning of most stainless steel products is to give the surfaces a brisk rubbing with a soft cloth soaked in warm water and a gentle detergent, or mild mixture of ammonia. Rubbing should, to the extent possible, follow the polish lines of the steel, and always insure thorough rinsing after cleaning.

Although some products are called "stainless steel cleaners," some may contain abrasives which could scratch the surface, (compromising the protective chrome-oxide film), and some many contain chlorine bleach which will dull, tarnish or discolor the surface if not completely removed.

After the stainless surfaces have been thoroughly cleaned, a good quality car wax may be applied to help maintain the finish.

## NOTE

Stainless steel products should never be installed, or stored in close proximity to chlorine chemicals.

Whichever cleaning product you chose, it should be used in strict accordance with the instructions of the cleaner manufacturer.

## EXTENDED NON-USE

---

### Extended Non-Use

#### Vacation/Holiday - Prolonged Shutdown

The following steps are recommended for periods of extended non-use:

1. Remove all consumable content from the unit.
2. Disconnect the power cord from its outlet/socket and leave it disconnected until the unit is returned to service.
3. Turn off the water supply.
4. If ice is on the evaporator, allow ice to thaw naturally.
5. Clean and dry the interior of the cabinet. Ensure all water has been removed from the unit.
6. Disconnect the water and drain line (if applicable) making sure all water is removed from the lines.
7. The door must remain open to prevent formation of mold and mildew. Open door a minimum of 2" (50 mm) to provide the necessary ventilation.

### Winterization

If the unit will be exposed to temperatures of 40°F (5°C) or less, the steps above must be followed. In addition, P60 drain pumps in clear ice machines must be drained according to the following procedure:

1. Remove the drain pump from the ice machine.
2. Drain the water in the pump's reservoir by turning the pump upside down and allowing the water to drain through the pump's inlet and vent tube fittings.
3. After water is drained, reinstall the drain pump and reattach all connections.

For questions regarding winterization, please call Marvel at 616.754.5601.



Damage caused by freezing temperatures is not covered by the warranty. Do not put anti-freeze in your unit.

## OBTAINING SERVICE

---

### If Service is Required:

- If the product is within the first year warranty period please contact your dealer or call Marvel Customer Service at 616.754.5601 for directions on how to obtain warranty coverage in your area.
- If the product is outside the first year warranty period, Marvel Customer Service can provide recommendations of service centers in your area. A listing of authorized service centers is also available at [www.marvelrefrigeration.com](http://www.marvelrefrigeration.com) under the service and support section.
- In all correspondence regarding service, be sure to give the service number, serial number, and proof of purchase.
- Try to have information or description of nature of the problem, how long the appliance has been running, the room temperature, and any additional information that may be helpful in quickly solving the problem.
- Table "B" is provided for recording pertinent information regarding your product for future reference.

| For Your Records  |  |
|---|--|
| Date of Purchase  |  |
| Dealer's name   |  |
| Dealer's Address  |  |
| Dealer's City   |  |
| Dealer's State  |  |
| Dealer's Zip Code   |  |
| Appliance Serial Number                                       |  |
| Appliance Service Number                                      |  |
| Date Warranty Card Sent (Must be within 10 days of purchase). |  |

Table B

# MANUAL CONTROL ICEMAKER & COMBO

SEE COMPRESSOR DIAGRAMS

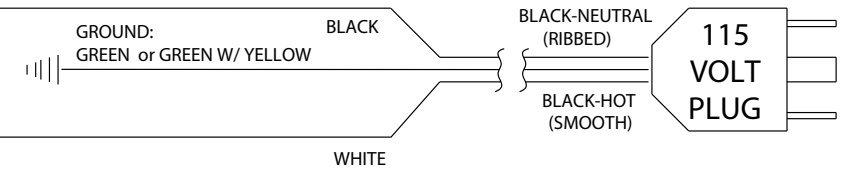
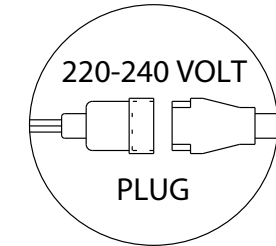
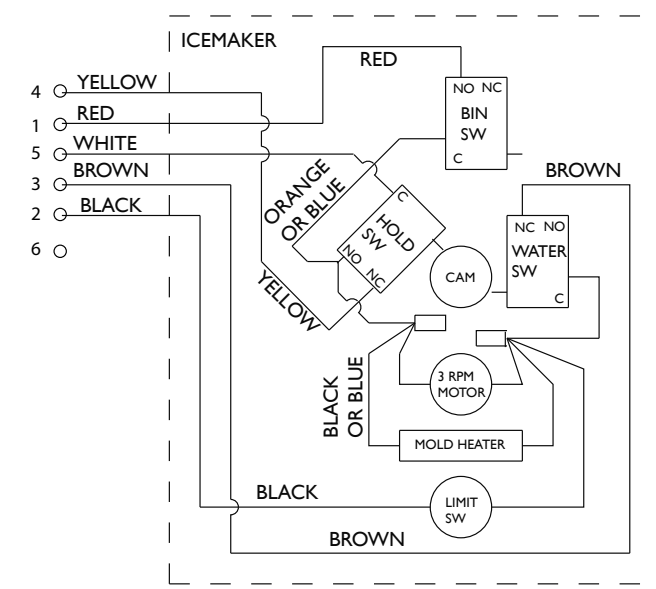
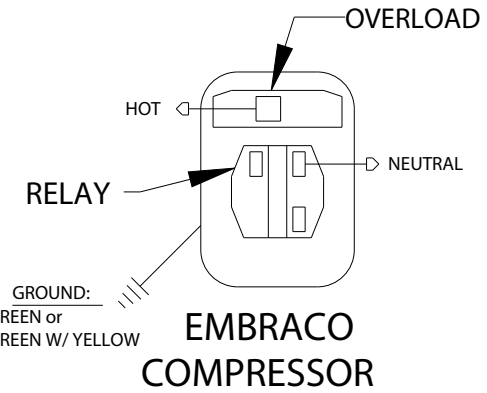
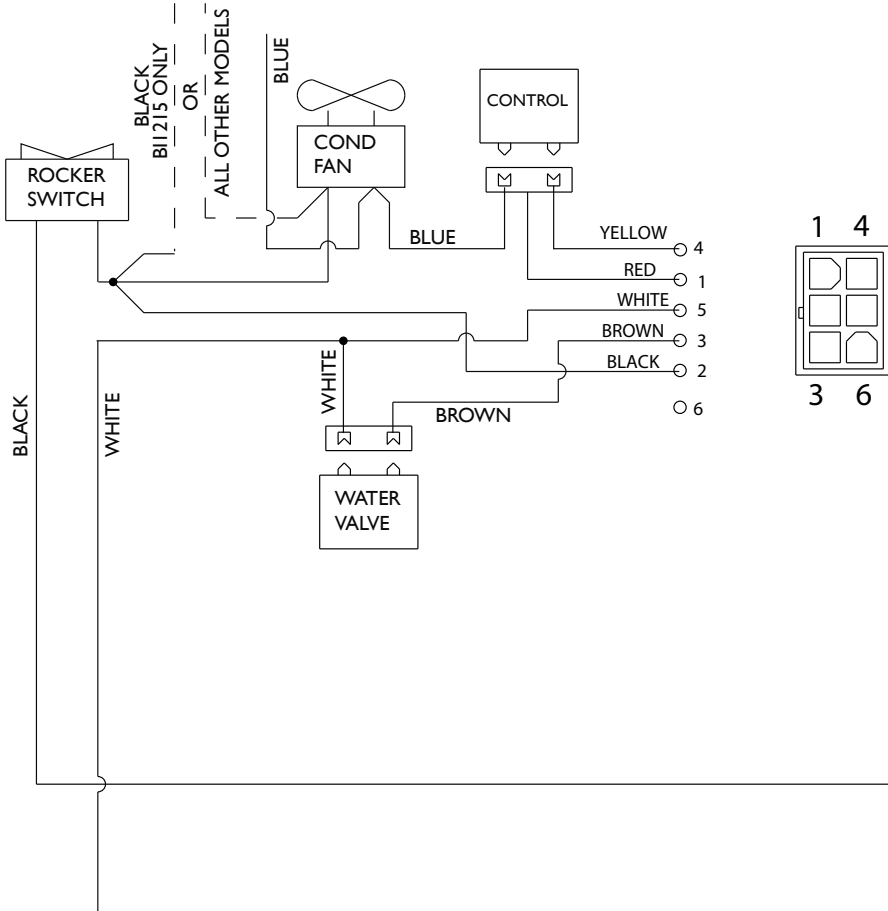

## Product Liability

Field service technicians are authorized to make an initial assessment in the event of reported damages. If there are any questions about the process involved, the technician should call Marvel for further explanation.

While inspecting for defects or installation issues, photos should be taken to document any damages or issues found.

During the assessment, if the service technician is able to find the source of the damage and it can be resolved by replacement of a part, the servicer is authorized to replace the part in question. The part that caused the damage must be returned to Marvel in its entirety. The part must be clearly labeled with the serial number of the unit it was removed from, the date, and the servicer who removed the part.

If the service technician determines the damage is the result of installation issues (water connection/drain, etc.), the consumer would be notified and the issues shall be resolved at the direction of the consumer.

If damage is evident and the service technician is unable to find the source, Marvel must be contacted at 616.754.5601 for further direction.

1260 E. Van Deirse St • Greenville, MI 48838

T: +1.616.754.5601

Website: [www.marvelrefrigeration.com](http://www.marvelrefrigeration.com)

**The original refrigeration experts since 1892.**



## Warranty Claims

The following information defines the parameters for filing a warranty claim:

- Valid serial number needed
- Valid model number needed
- Claims must be submitted online at [www.marvelservice.com](http://www.marvelservice.com)
- 60 day submittal deadline from date of completed service
- Only one repair or unit per warranty claim
- Part order numbers will be required when submitting for warranty labor

Units must be registered prior to warranty submittal. Customers may register at [www.marvelrefrigeration.com](http://www.marvelrefrigeration.com). A proof of purchase is required. We also accept the following information to update warranty:

- New construction occupancy documents
- Closing paperwork
- Final billing - Remodel

Warranty parts will be shipped at no charge after Marvel confirms warranty status. Please provide the model, serial number, part number and part description. Some parts will require color or voltage information.

**17 14862 05 0527**

---

Year      Month      Day      Factory  
   use Only

# Service Parts List

marvelrefrigeration.com  
616-754-5601

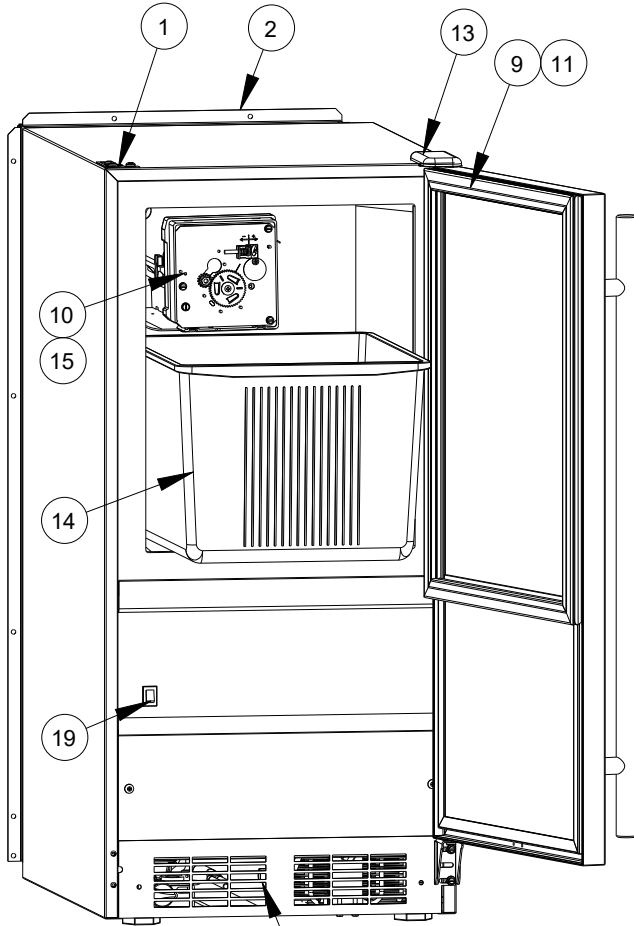

| MACR215-SS01B |                                |             |
|---------------|--------------------------------|-------------|
| Item          | Description                    | Part Number |
| 1             | ANTI TIP BRACKET W/SCREWS      | 80-54239-00 |
| 2             | BACK PANEL ACR115              | 80-54754-00 |
| 3             | COMPRESSOR EM2C46CLC,115V,R600 | 80-55658-11 |
| 4             | CONDENSER ASSEMBLY             | 80-54322-00 |
| 5             | CONDENSER FAN BLADE            | 80-54379-00 |
| 6             | CONDENSER FAN W/BLADE          | 80-54378-00 |
| 7             | CONTROL W/KNOB                 | 80-54568-01 |
| 8             | CONTROL KNOB                   | 80-54382-00 |
| 9             | DOOR ASSY W/HINGES, ADA, SS    | 80-55534-01 |
| 10            | FACEPLATE 115V, R600           | 80-54523-01 |
| 11            | GASKET, DOOR                   | 80-55428-00 |
| 12            | GRILLE - MARVEL ADA            | 80-55547-00 |
| 13            | HINGE ASSEMBLY                 | 80-55595-00 |
| 14            | ICE BUCKET                     | 80-54386-00 |
| 15            | ICEMAKER, 115V, R600           | 80-54372-00 |
| 16            | LEG LEVELERS (4)               | 80-54019-00 |
| 17            | PACKAGING *                    | 80-54387-00 |
| 18            | POWER CORD, EXTERNAL *         | 80-55519-00 |
| 19            | ROCKER SWITCH                  | 80-55603-00 |
| 20            | WATERLINE ASSEMBLY             | 80-54722-00 |
| 21            | WATER VALVE ASSEMBLY           | 80-54356-00 |
| 22            | WIRE ASSEMBLY, MAIN *          | 80-55638-12 |
| 23            | WIRE ASSEMBLY, CONTROL *       | 80-55638-11 |

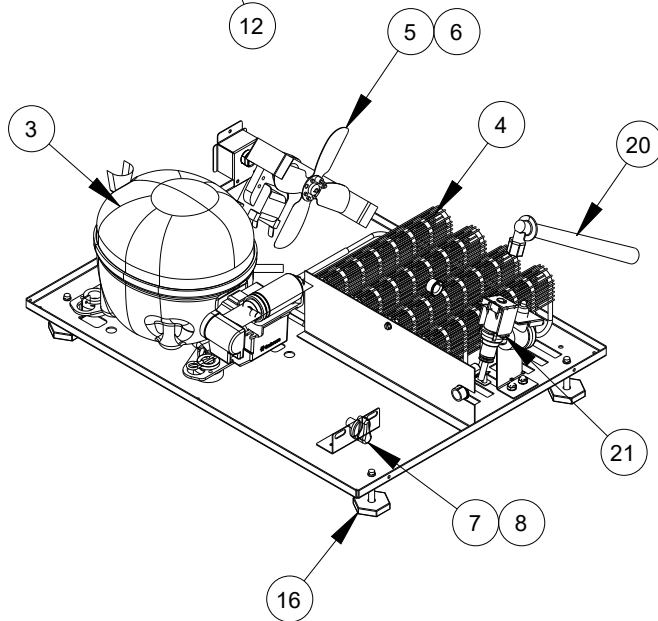

\* NOT PICTURED

---

## Ordering Replacement Parts

**Parts may be ordered online at [partsformarvel.com](http://partsformarvel.com)**

Or contact:

[www.marvelrefrigeration.com](http://www.marvelrefrigeration.com) (Servicers choose "Login" for service account).

Phone Number: (616) 754-5601

### **NOTICE**

**Use only genuine Marvel replacement parts. The use of non-Marvel parts can reduce performance, damage the unit, and void the warranty.**

Warranty parts will be shipped at no charge after Marvel confirms warranty status. Please provide the model, serial number, part number and part description. Some parts will require color or voltage information.

Marvel requires the return of original parts, we will inform you when the parts order is taken. This requirement will be noted on your packing list. A prepaid shipping label will be emailed to you. Please enclose a copy of the parts packing list and be sure the model and serial numbers are legible on the paperwork. Tag the part with the reported defect.

Customers and non-authorized servicers may order non-warranty parts at [www.partsformarvel.com](http://www.partsformarvel.com). Authorized servicers with a servicer login may order non-warranty parts at [www.marvelrefrigeration.com](http://www.marvelrefrigeration.com).

## R-600A Specifications & Handling

**WARNING**

Flammability warnings for a pure-iso-butane refrigerant.



Gloves and Eye Protection must be used.



R-600a is considered non-toxic, but is flammable when mixed with air.

Keep a dry powder type fire extinguisher in the work area.



R-600a is heavier than air, do not allow any leakage/migration to low areas such as basements and stairs.

Never use a torch on a fully charged refrigeration system.

Never substitute Marvel OEM replacement parts or methods of construction.

R-600a must be stored and transported in approved containers.

**⚠ WARNING**

**Only skilled and well trained service technicians permitted to service R-600a equipped products.**

**All tools and equipment must be approved for use with R-600a refrigerant.**

**Local, state and federal laws, standards must be observed along with proper certification and licensing.**

**Ventilation is required during servicing.**

**No conversions to R-600a from any other refrigerants. OEM R-600a equipped unit only.**

**Service area must be free of ignition sources.**

**No smoking is allowed in the service area.**

**All replacement electrical components must be OEM and installed properly (sealed and covered).**

**If the evaporator is cold prior to service, it must be thawed prior to service.**

**When using a vacuum pump, start pump before opening refrigeration system.**

**Vacuum pump and recovery equipment should be at least 10 feet from the work area.**

**It is recommended that a simple LPG gas detector is on site during service.**

**Ensure that all R-600a is removed from the system prior to brazing any part of the sealed system.**

**Only a clean, dry leak free system should be charged with R-600a.**

### **R-600A SPECIFICATIONS/LABELING**

R-600a equipped products are labeled (both the unit and the compressor).

R-600a is colorless and odorless.

R-600a is considered non-toxic, but is flammable when mixed with air.

Do not remove or alter any R-600a labeling on the product.

Use only a refrigerant grade R-600a from a properly labeled container.

### **RECOVERING/RECLAIMING R-600A**

(R-600a has been exempted from recovery/reclaiming requirements by the US EPA)

Recovery/Reclaiming equipment must be approved for use with R-600a.

Ensure the evaporator is at room temperature prior to recovery/reclaiming R-600a.

Use a common piercing pliers or piercing valve to remove R-600a from the compressor process tube. (Note: Piercing devices must not be left on the system and must be replaced with a Schrader type valve.)

Evacuate/reclaim via the piecing pliers to ensure the system is empty of R-600a before any system work is performed.



The recovery cylinder must be evacuated (no air inside) prior to accepting R-600a.

The recovery cylinder must not be filled more than 45% safe fill level and refrigerants must not be mixed.

The recovery cylinder must be clearly marked with R-600a and Flammable Warning labels.

Ensure proper ventilation during recovery/reclaiming of R-600a.

Start vacuum pump/recovery pump prior to piercing the compressor process tube.

Follow recovery/reclaim OEM instructions for the specific equipment used.

### SYSTEM REPAIR

Ensure no residual R-600a refrigerant is left within the system prior to repair (simple venting is not sufficient).

Evacuate and charge with dry nitrogen for leak checks.

Repair leaks or replace system parts as required.

When re-brazing, the system must be purged with dry nitrogen and at least one access point open to the atmosphere.

When re-brazing, proper ventilation is required along with constant monitoring for the presence of R600a refrigerant.

The filter dryer must be replaced any time the sealed system is serviced.

No system should be open to the atmosphere for longer than 15 minutes to avoid moisture migration into the system components.

### LEAK DETECTION

After removal of the R-600a, the unit can be charged with dry nitrogen or helium.

Electronic leak detection or soap solution can be used to check for nitrogen/helium leaks.



Never use a halide torch or lighted match to check the system for leaks at any time.

The high side of the refrigeration system (compressor discharge to outlet of drier) must be leak tested with the compressor running.

The low side of the refrigeration system (evaporator, compressor and suction line) must be leak tested with the compressor off (equalized pressure).

### **RECHARGING**

No air is ever to be allowed inside the refrigeration system (R-600a refrigerant or dry nitrogen only).

Never use a torch on a fully charged refrigeration system.

Install a Schrader Type access port on the compressor process stub.



Evacuate the system to 100 microns prior to charging.

Weigh in the R-600a charge using a refrigerant scale. (run compressor an extra two minutes to clear the charging hoses).

Seal the Schrader Type access port, a proper cap and seal must be used to close the system.



### **SUMMARY**

Safely handling R-600a requires proper procedures and training.

R-600a approved service tools must be used.

R-600a labeling must not be removed or altered.

Proper ventilation during service is required.

Never apply a torch to a charged R-600a refrigeration system.

Use OEM replacement service parts and do not alter the construction of the unit.

## System Diagnosis Guide

### REGRIGERATION SYSTEM DIAGNOSIS GUIDE

| <b>System Condition</b>     | <b>Suction Pressure</b>           | <b>Suction Line</b>             | <b>Compressor Discharge</b> | <b>Condenser</b>  | <b>Capillary Tube</b>             | <b>Evaporator</b>  | <b>Wattage</b>     |
|-----------------------------|-----------------------------------|---------------------------------|-----------------------------|---|-----------------------------------|--|--------------------|
| <b>Normal</b>               | Normal                            | Slightly below room temperature | Very hot                    | Very hot  | Warm                              | Cold   | Normal             |
| <b>Overcharge</b>           | Higher than normal                | Very cold may frost heavily     | Slightly warm to hot        | Hot to warm   | Cool                              | Cold   | Higher than normal |
| <b>Undercharge</b>          | Lower than normal                 | Warm-near room temperature      | Hot                         | Warm  | Warm                              | Extremely cold near inlet - Outlet below room temperature            | Lower than normal  |
| <b>Partial Restriction</b>  | Somewhat lower than normal vacuum | Warm-near room temperature      | Very hot                    | Top passes warm - Lower passes cool (near room temperature) due to liquid | Room temperature (cool) or colder | Extremely cold near inlet - Outlet below room temperature backing up | Lower than normal  |
| <b>Complete Restriction</b> | In deep vacuum                    | Room temperature (cool)         | Room temperature (cool)     | Room temperature (cool)   | Room temperature (cool)           | No refrigeration   | Lower than normal  |
| <b>No Gas</b>               | 0 PSIG to 25"                     | Room temperature (cool)         | Cool to hot                 | Room temperature (cool)   | Room temperature (cool)           | No refrigeration   | Lower than normal  |

---

## Defrost

This unit defrosts every 4 hours of compressor runtime for 45 minutes. If you have verified that the unit does not have an ambient air leak, utilize the **Control Operation - Service** section and adjust unit to defrost every 3 hours for 60 minutes. Also, adjust the #2 thermistor to -4 instead of 0.

# REPLACE ICE MAKER

The new ice maker assembly you have received will have a plug-in connection. In some instances, you may need to cut plug from cable and hard-wire the connections.

## Remove Ice Maker

1. Unplug the unit.
2. Disconnect ice maker wire harness at plug
3. Disconnect thermistor plug.
4. Remove water inlet tube.
5. Remove front cover.
6. Advance ejector blade to the 3 o'clock position by turning 5/16" hex head on the small brass gear counterclockwise.
7. Remove three screws from the wall freezer housing.
8. Remove ice maker assembly.

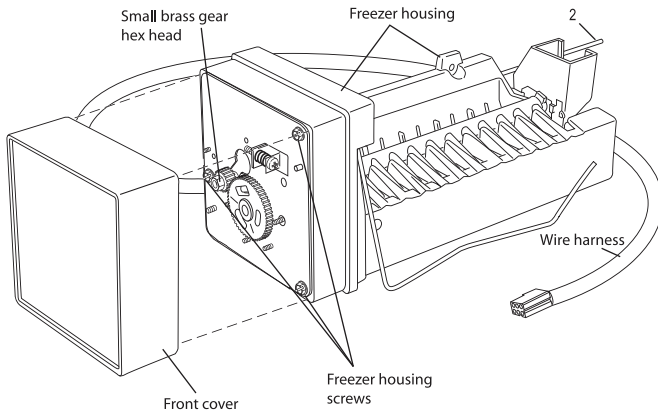

## Install Ice Maker

1. If ice maker sits on evaporator (as shown), be sure to apply the included Alumilastic paste.

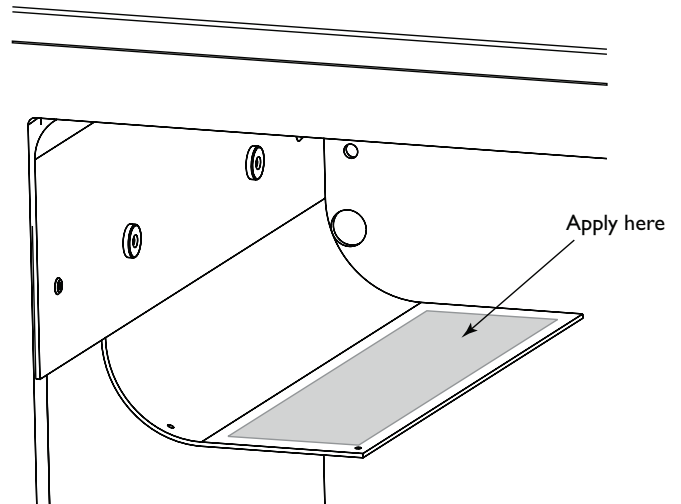

2. Reconnect plug.
3. Reconnect thermistor plug.
4. Insert water inlet tube.
5. Apply Permagem to all exit holes on back of unit.
6. Install back panel.
7. Plug in unit and test.

# HOUSEHOLD PRODUCT WARRANTY

---

## Marvel Refrigeration (Marvel) Limited Warranty

### ONE YEAR LIMITED PARTS & LABOR WARRANTY

For one year from the date of original purchase, this warranty covers all parts and labor to repair or replace any part of the product that proves to be defective in materials or workmanship. For products installed and used for normal residential use, material cosmetic defects are included in this warranty, with coverage limited to 60 days from the date of original purchase. All service provided by Marvel under the above warranty must be performed by a Marvel factory authorized servicer, unless otherwise specified by Marvel. Service provided during normal business hours.

### TWO YEAR LIMITED PARTS & LABOR WARRANTY (MARVEL PROFESSIONAL PRODUCTS)

For two years from the date of original purchase, this warranty covers all parts and labor to repair or replace any part of the product that proves to be defective in materials or workmanship. For products installed and used for normal residential use, material cosmetic defects are included in this warranty, with coverage limited to 60 days from the date of original purchase. All service provided by Marvel under the above warranty must be performed by a Marvel factory authorized servicer, unless otherwise specified by Marvel. Service provided during normal business hours.

### AVAILABLE THIRD YEAR LIMITED WARRANTY (MARVEL PROFESSIONAL PRODUCTS)

For designated Marvel Professional product, Marvel offers a one year extension of the two year warranty coverage from the date of purchase, free of charge. To take advantage of this third year warranty, you must register your product with Marvel within 60 days from the date of purchase at [marvelrefrigeration.com](http://marvelrefrigeration.com) and provide proof of purchase. Nugget Ice Machine proof of purchase must include the purchase of an in-line water filter and filter head to qualify for this additional limited warranty.

### LIMITED FIVE YEAR SEALED SYSTEM WARRANTY

For five years from the date of original purchase, Marvel will repair or replace the following parts, labor not included, that prove to be defective in materials or workmanship: compressor, condenser, evaporator, drier, and all connecting tubing. All service provided by Marvel under the above warranty must be performed by a Marvel factory authorized servicer, unless otherwise specified by Marvel. Service provided during normal business hours.

### WARRANTY TERMS

These warranties apply only to products installed in any one of the fifty states of the United States, the District of Columbia, or the ten provinces of Canada. The warranties do not cover any parts or labor to correct any defect caused by negligence, accident or improper use, maintenance, installation, service, repair, acts of God, fire, flood or other natural disasters. The product must be installed, operated, and maintained in accordance with the Marvel User Guide.

The remedies described above for each warranty are the only ones that Marvel will provide, either under these warranties or under any warranty arising by operation of law. Marvel will not be responsible for any consequential or incidental damages arising from the breach of these warranties or any other warranty, whether express, implied, or statutory. Some states do not allow the exclusion or limitation of incidental or consequential damages, so the above limitation or exclusion may not apply to you. These warranties give you specific legal rights, and you may also have other rights which vary from state to state.

Any warranty that may be implied in connection with your purchase or use of the product, including any warranty of merchantability or any warranty fit for a particular purpose is limited to the duration of these warranties, and only extends to five years in duration for the parts described in the section related to the five year limited warranty above. Some states do not allow limitations on how long an implied warranty lasts, so the above limitations may not apply to you.

- The warranties only apply to the original purchaser and are non-transferable.
- These warranties cover products installed and used for normal residential use only.
- The warranties apply to units operated outside only if designed for outdoor use by model and serial number.
- Replacement water filters, light bulbs, and other consumable parts are not covered by these warranties.
- The start of Marvel's obligation is limited to four years after the shipment date from Marvel.
- In-home instruction on how to use your product is not covered by these warranties.
- Food, beverage, and medicine loss are not covered by these warranties.
- If the product is located in an area where Marvel factory authorized service is not available, you may be responsible for a trip charge or you may be required to bring the product to a Marvel factory authorized service location at your own cost and expense.
- Units purchased after use as floor displays, and/or certified reconditioned units, are covered by the limited one year warranty only and no coverage is provided for cosmetic defects.
- Signal issues related to Wi-Fi connectivity are not covered by these warranties.

For parts and service assistance, or to find Marvel factory authorized service near you, contact Marvel Refrigeration:

[MarvelRefrigeration.com](http://MarvelRefrigeration.com) • [techsupport@MarvelRefrigeration.com](mailto:techsupport@MarvelRefrigeration.com) • +616.754.5601

1260 E. Van Deine St., Greenville, MI 48838



[www.marvelrefrigeration.com](http://www.marvelrefrigeration.com)

**Marvel Refrigeration**

1260 E. Van Deinse St.  
Greenville MI 48838

616.754.5601

All specifications and product designs subject to change without notice. Such revisions do not entitle the buyer to corresponding changes, improvements, additions, replacements or compensation for previously purchased products.