

Kitchen Cart / Island Cabinet

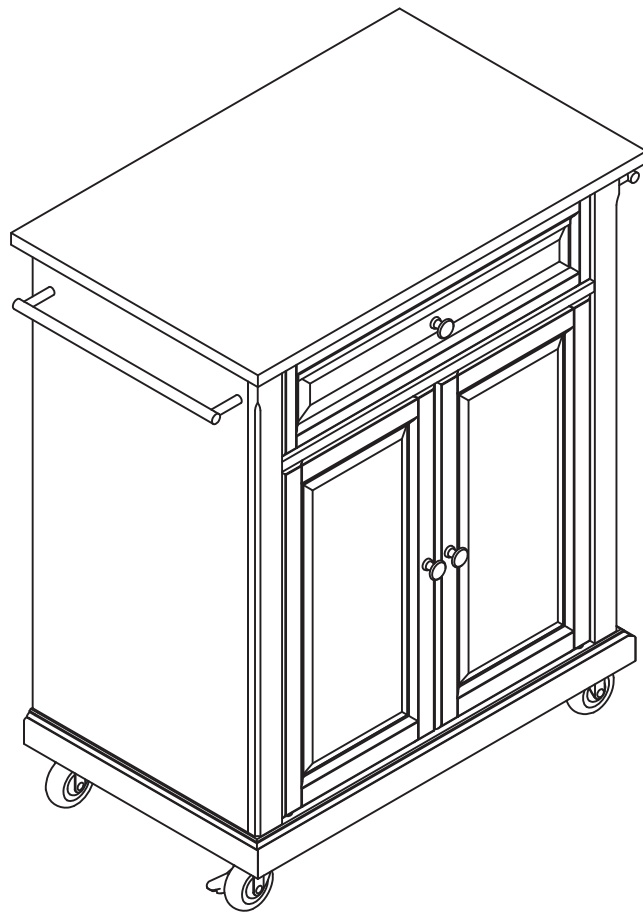





Congratulations! You have purchased a stylish piece of us. We strive to provide fine furniture products, built with quality materials and hand finished details. Please carefully follow the assembly instructions to ensure your furniture is assembled correctly to provide long lasting enjoyment.

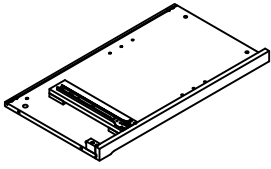
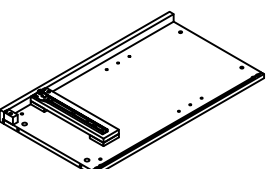
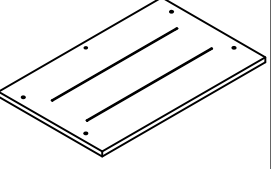
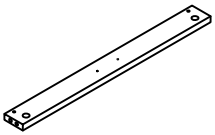
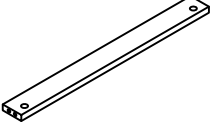
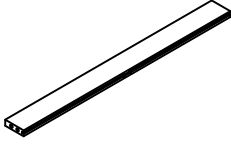

Should you experience any missing or damaged parts, **do not return to the store.** Please contact us directly.

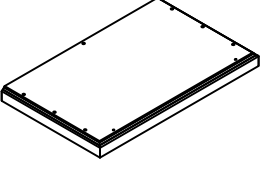
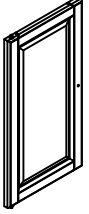
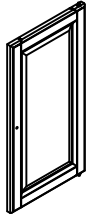
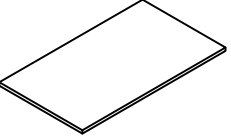
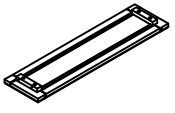
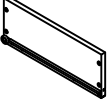
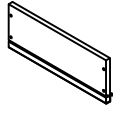
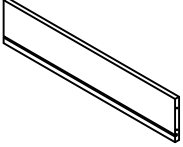
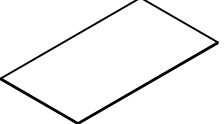
Care: Use a soft clean cloth that will not scratch the surface when dusting. Use of furniture polish is not necessary. Should you choose to use polishes, test in an inconspicuous area first. Use of solvents of any kind may damage your furniture's finish. To clean, simply use a soft clean cloth moistened with lukewarm water, then buff with a dry soft clean cloth.

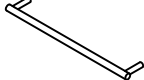
PART LIST

A 	B 	C  Ships separately	D 	E 
1 PC	1 PC	1 PC	1 PC	1 PC
F 	G 	H 	I 	J 
2 PCS	2 PCS	1 PC	1 PC	1 PC
K 	L 	M 	N 	O 
1 PC	1 PC	1 PC	1 PC	1 PC
P 	Q 	R 	S 	T 
1 PC	1 PC	2 PCS	2 PCS	2 PCS

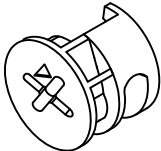
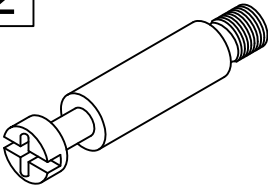
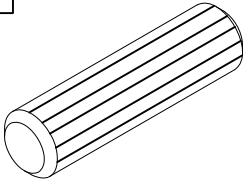
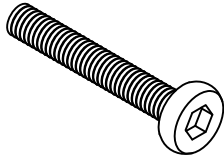
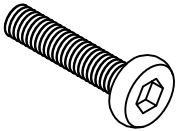
HARDWARE LIST

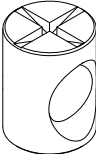
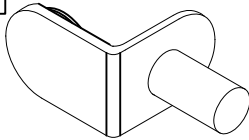
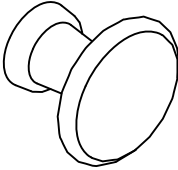
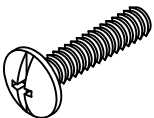
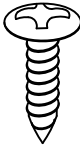
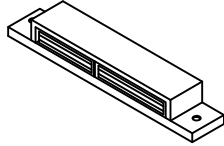
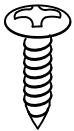
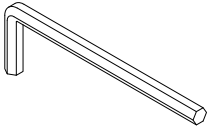
<p>1</p> 	<p>2</p> 	<p>3</p> 	<p>4</p> 
<p>CAM LOCK 12 PCS</p>	<p>CAM BOLT 12 PCS</p>	<p>WOOD DOWEL 16 PCS</p>	<p>Allen Bolt 4 PCS</p>
<p>5</p>  <p>1-1/4" *\varnothing1/4"*D11mm</p>	<p>6</p> 	<p>7</p> 	<p>8</p> 
<p>Short Allen Bolt 4 PCS</p>	<p>SCREW 8 PCS</p>	<p>BARREL NUT 4 PCS</p>	<p>SHELF HOLDER 4 PCS</p>
<p>9</p> 	<p>10</p> 	<p>11</p>  <p>12mm*\varnothing4*D9mm</p>	<p>12</p> 
<p>KNOB 3 PCS</p>	<p>ROUND HEAD BOLT 3 PCS</p>	<p>ROUND HEAD SCREW 16 PCS</p>	<p>DOUBLE MAGNET 1 PC</p>
<p>13</p> 	<p>14</p> 		
<p>ROUND HEAD SCREW 2 PCS</p>	<p>Allen Wrench 1 PC</p>		

Tools needed: Allen Wrench (Part #14) Included
Phillips Head Screwdriver (Not included)

Note: Wood dowels (Part #3) are for alignment only when assembling your furniture. Additional clearance between the wood dowels and pre-drilled holes is intended for ease of assembly.

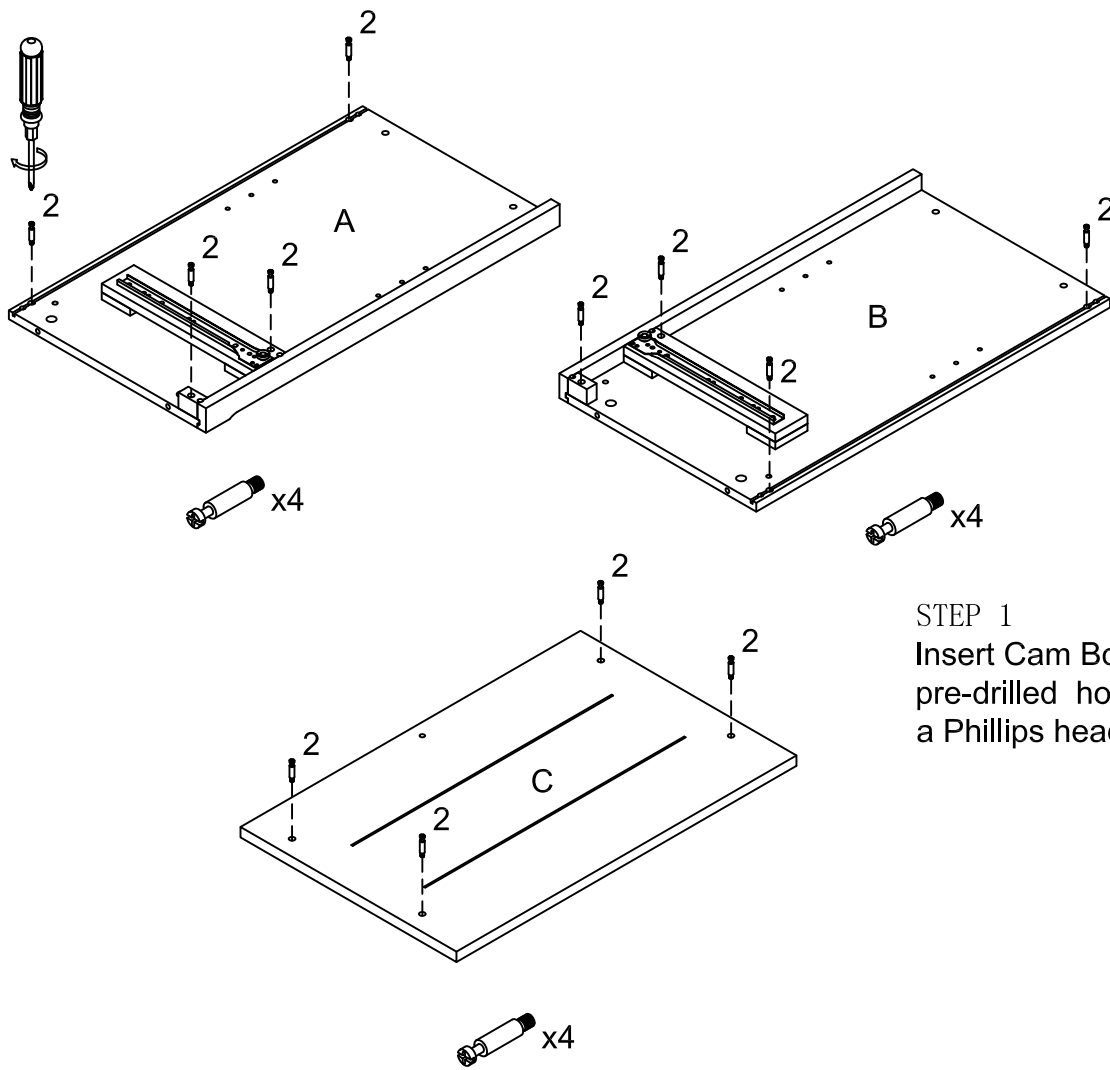

STEP 1
 Insert Cam Bolts (part # 2) into pre-drilled holes of parts A,B,C using a Phillips head screw driver as shown.

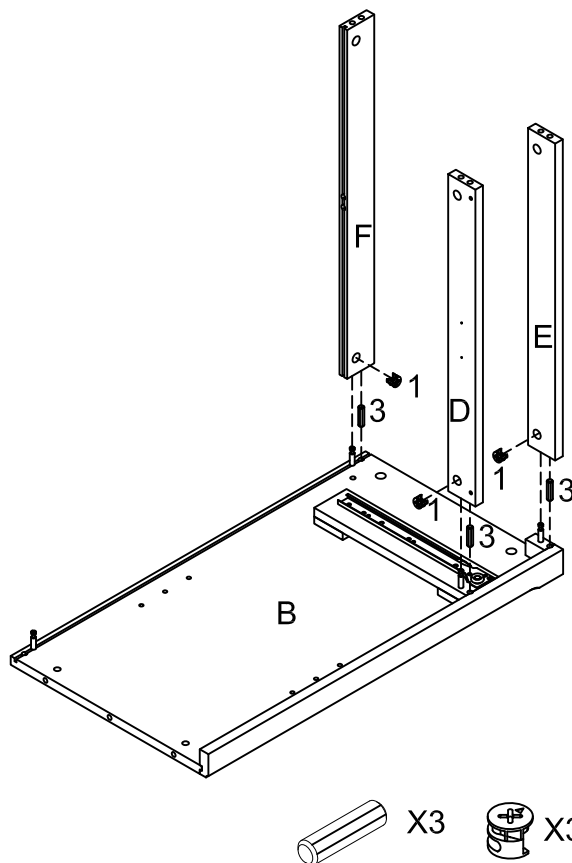

STEP 2
 Attach rails D, E, & F to Part B with wood dowels & Cam locks as shown.

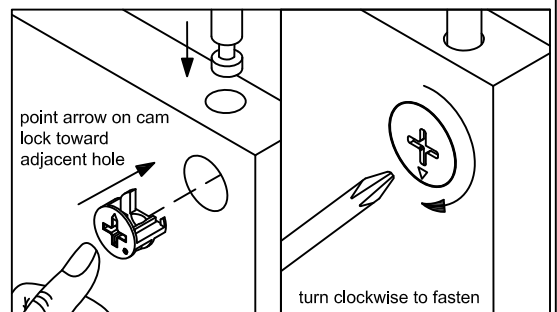
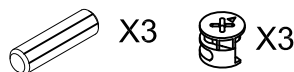

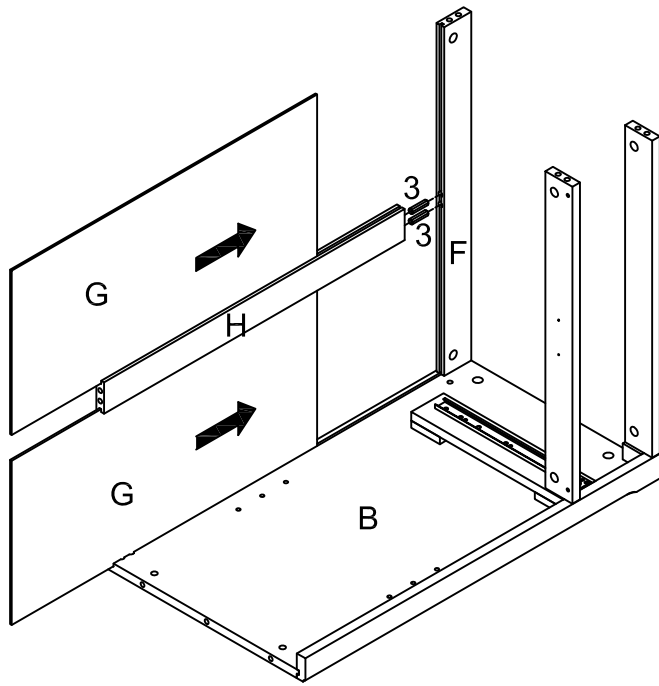

STEP 3

Slide back panel G into grooves of Part B & Rail F as shown. Set Rail H into place on back panel G and into rail F using wood dowels as shown. Slide back panel G into grooves of rails H & F.

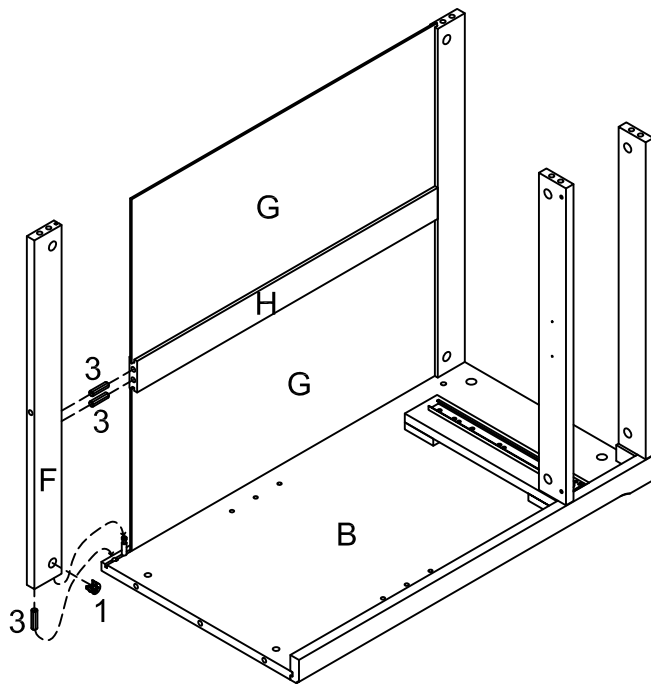
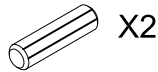

STEP 4

Attach Rail F to Rail H using wood dowels (Part #3) & Cam Locks (Part #1) as shown.

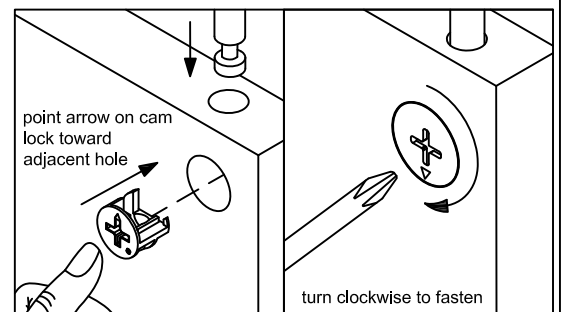
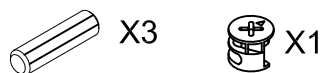

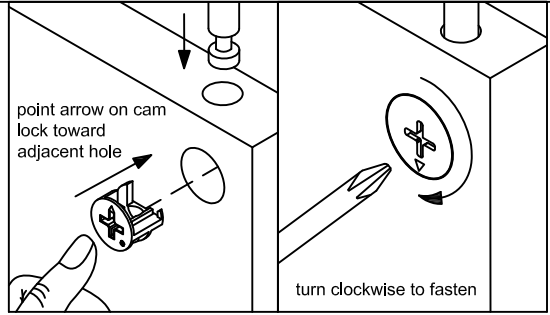
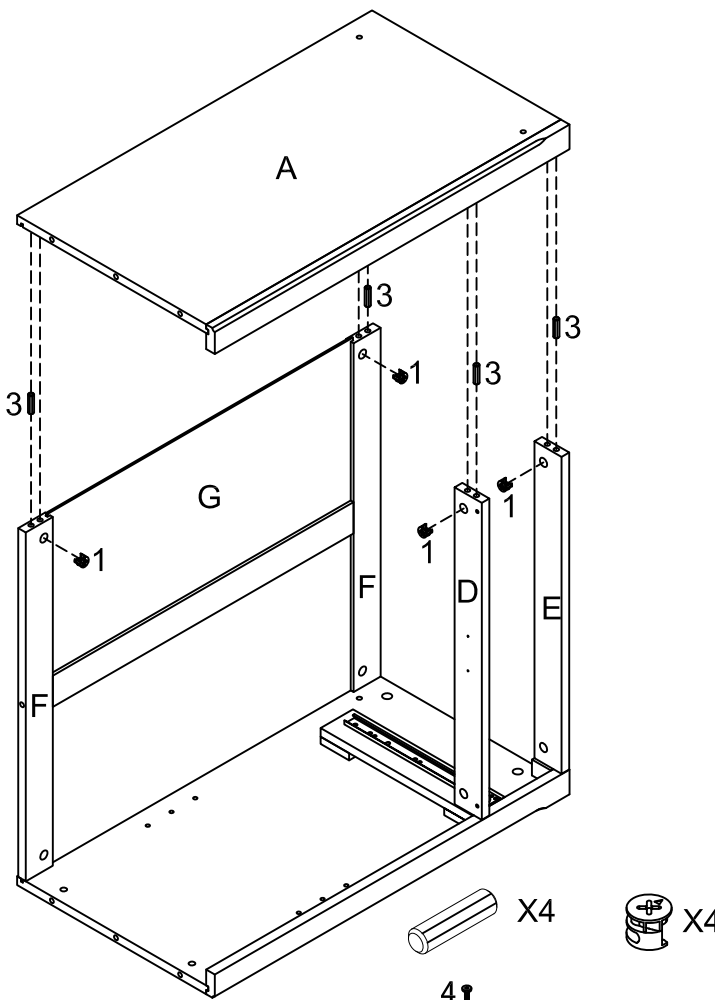

STEP 5
 Attach Part A to Parts D, E, & F using wood dowels & Cam locks as shown. Carefully turn cabinet over so that rails E & F are flat on the floor.

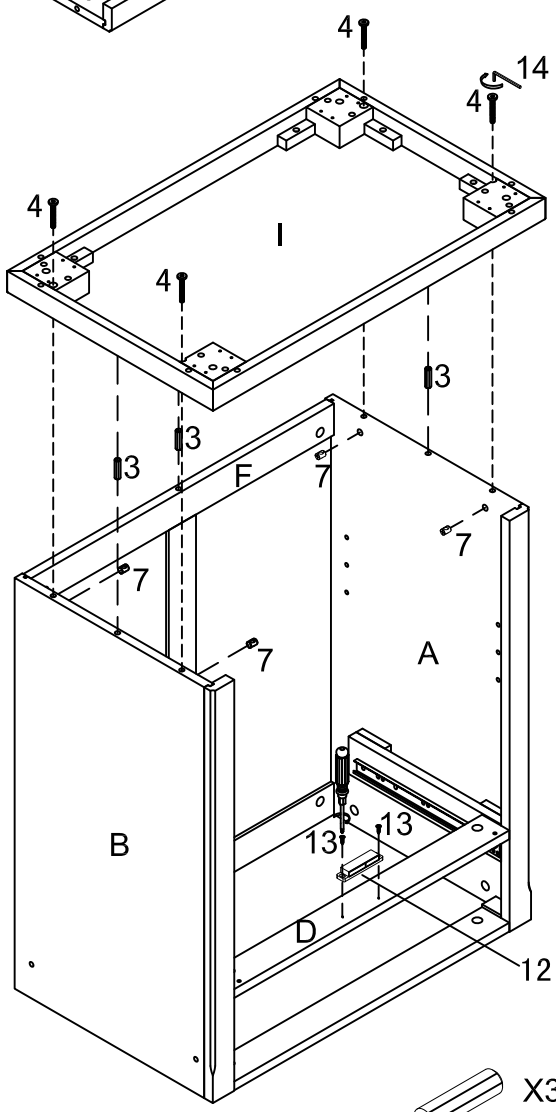
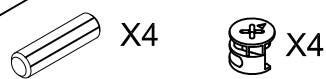

STEP 6
 Attach Base I to cabinet using Wood Dowels (Part #3), Allen Bolts (Part #4) & Barrel Nuts (Part #7) as shown. Attach Double Magnet (Part #12) to Rail D using Round Head Screws (Part #13) as shown.



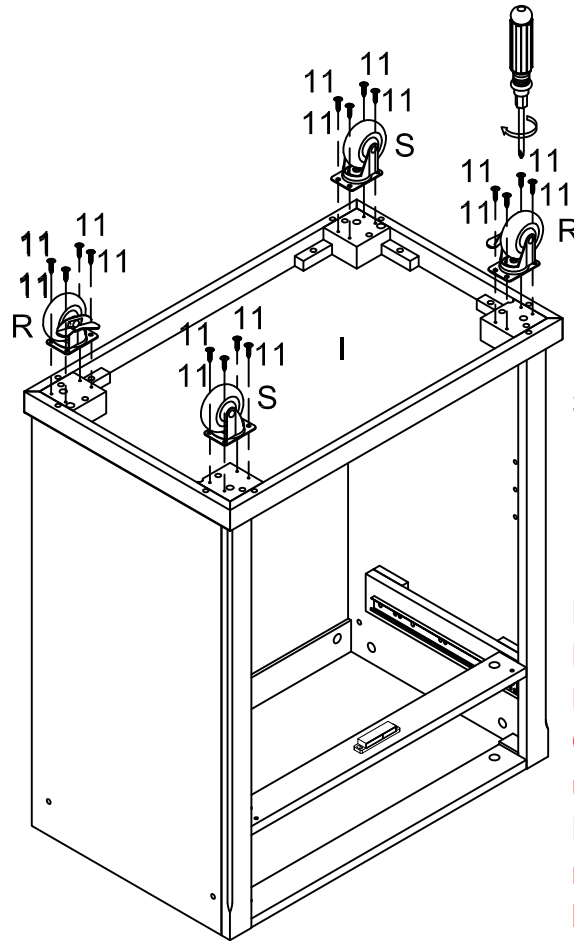

STEP 7
 Attach Locking Casters (Part S) & Casters (Part R) to Base I using Round Head Screws (Part #11) as shown.

Note: IF YOU PURCHASED A KITCHEN ISLAND WITH WOOD LEGS, DO NOT ATTACH THE CASTERS. Attach the wood legs using Hex Socket Head Bolts & Wood Dowels (as shown in instruction manual included in carton with the legs).

Carefully turn cabinet over with legs or casters on the floor.

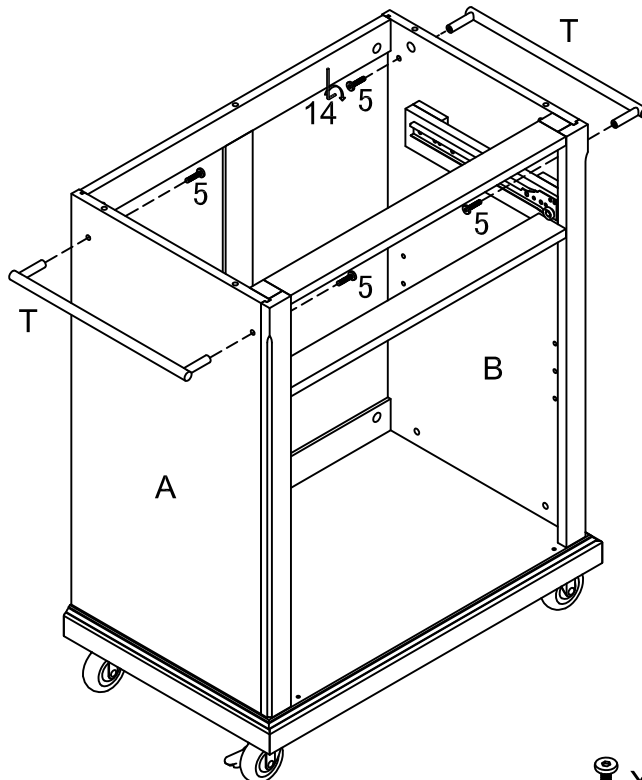

STEP 8
 Attach towel bars T to Side Panels A & B using Short Allen Bolts (Part #5) as shown.



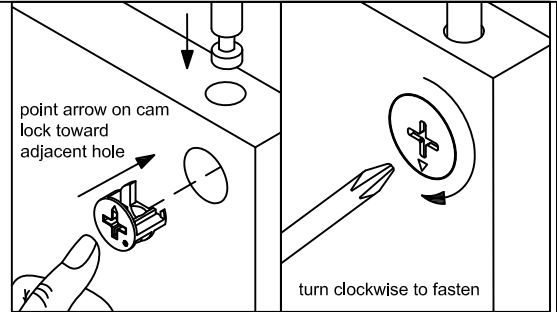
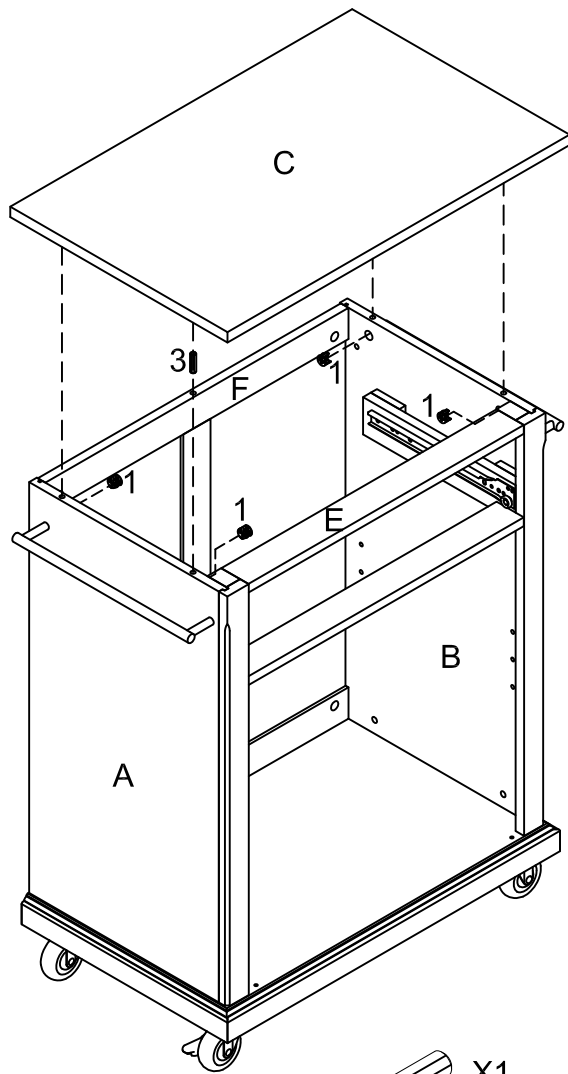

STEP 9
 Attach Top C to cabinet using Wood Dowel (Part # 3) & Cam Locks (Part # 1) as shown.

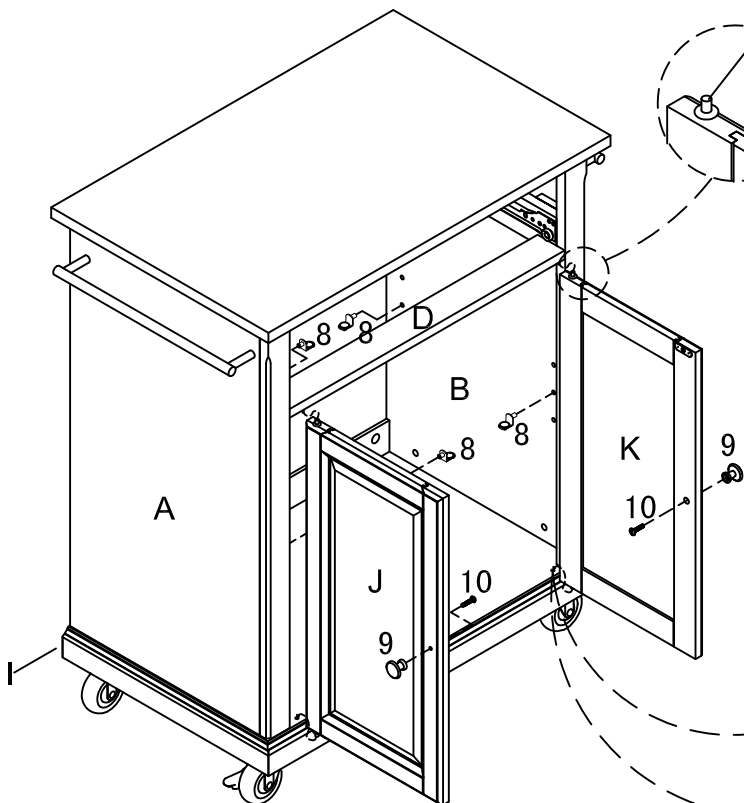
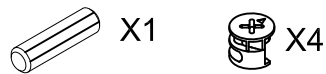



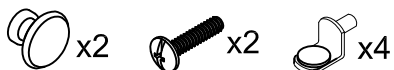

Pin Hinge

STEP 10
 Attach Knobs (Part #9) to doors J & K using Round Head Bolts (Part #10) as shown. Attach doors to cabinet by placing bottom Pin Hinge into pre-drilled holes in cabinet base & depressing top spring loaded Pin hinge to fit door into place in Rail D. Insert Shelf Holders (Part #8) into desired position.

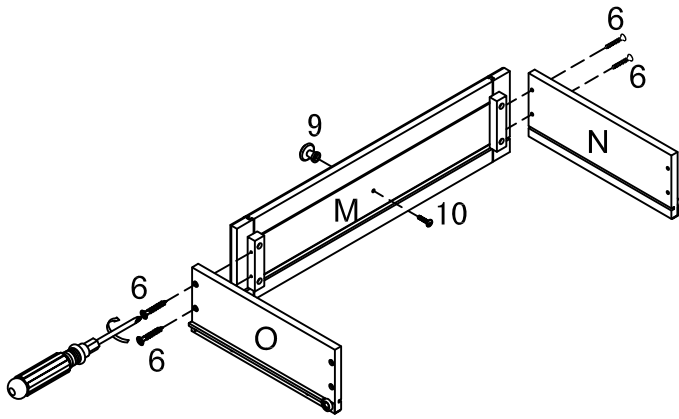

NOTE: Be sure Pin Hinges have extended fully into pre-drilled holes to secure doors into place.



 x4
  x1
  x1

STEP 11

Assemble drawers by Attaching Drawer Front M to Drawer Sides O & N using Screws (Part # 6) & Phillips Head screw driver as shown. Attach Knob (Part # 9) to Part M with Round Head Bolt (Part # 10) as shown.

NOTE: Be sure that wheels on drawer glides are at the opposite side of the drawer front.

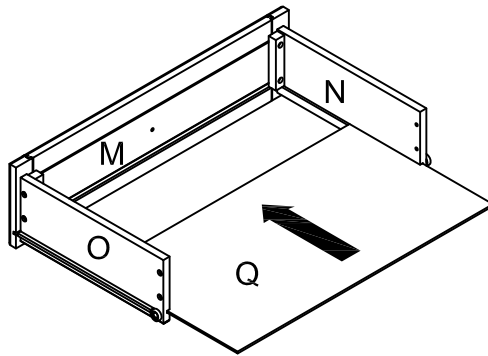

STEP 12

Insert Bottom Panel Q into the grooves of Parts O, M & N as shown.

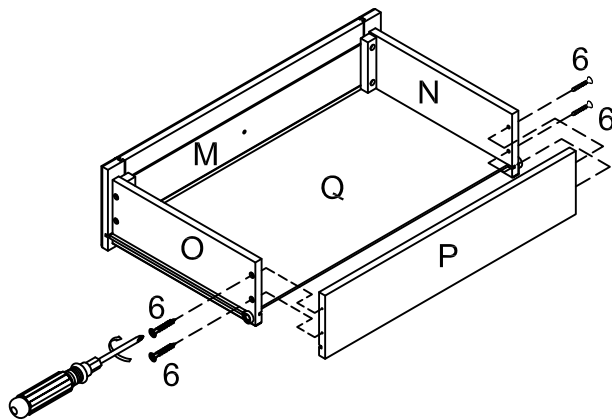

 x4

STEP 13

Attach Back Panel P to Parts O & N using Screws (Part # 6) & Phillips Head screw driver as shown.

STEP 14

Insert Shelf L & drawer in to cabinet as shown.

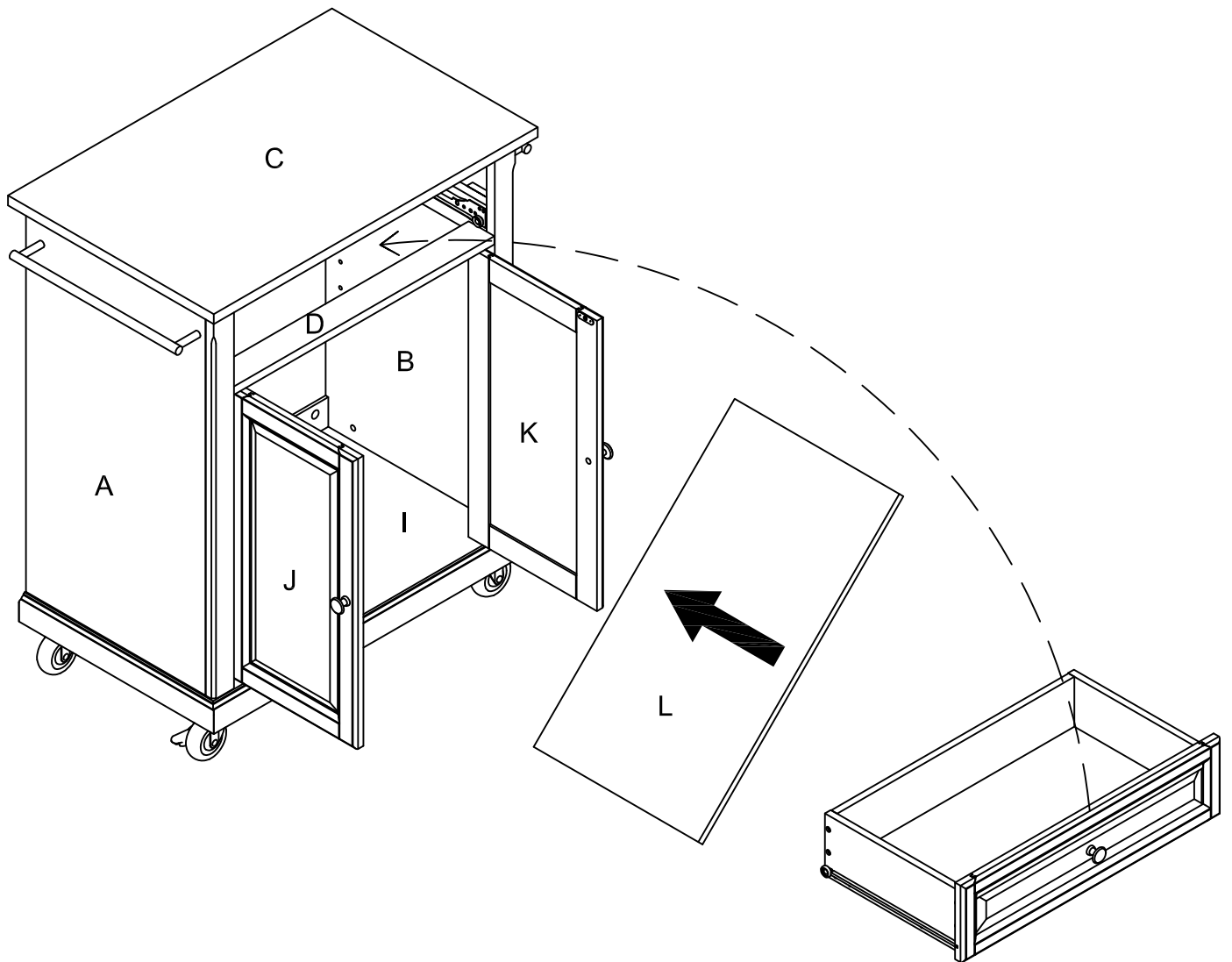

Limited Manufacturers Warranty

Our products are warranted against defects in material and workmanship for a period of 90 days beginning from the date of sale. Should any parts be missing or defective, we will replace or repair the parts for a period of 90 days from the date of purchase.

Should you experience any missing or damaged parts, do not return to the store.

Please visit our website or contact us.

This warranty gives the purchaser specified legal rights in addition to any rights which may vary from state to state.

In accordance with the "Moss-Magnuson Warranty Act" of July 10, 1975, this is termed a "limited warranty" which in no way compromises Our high standards of Quality and Workmanship.