

ASSEMBLY INSTRUCTIONS
(INSTRUCTIONS DE MONTAGE)
24 INCHES BATH VANITY (COMBO)

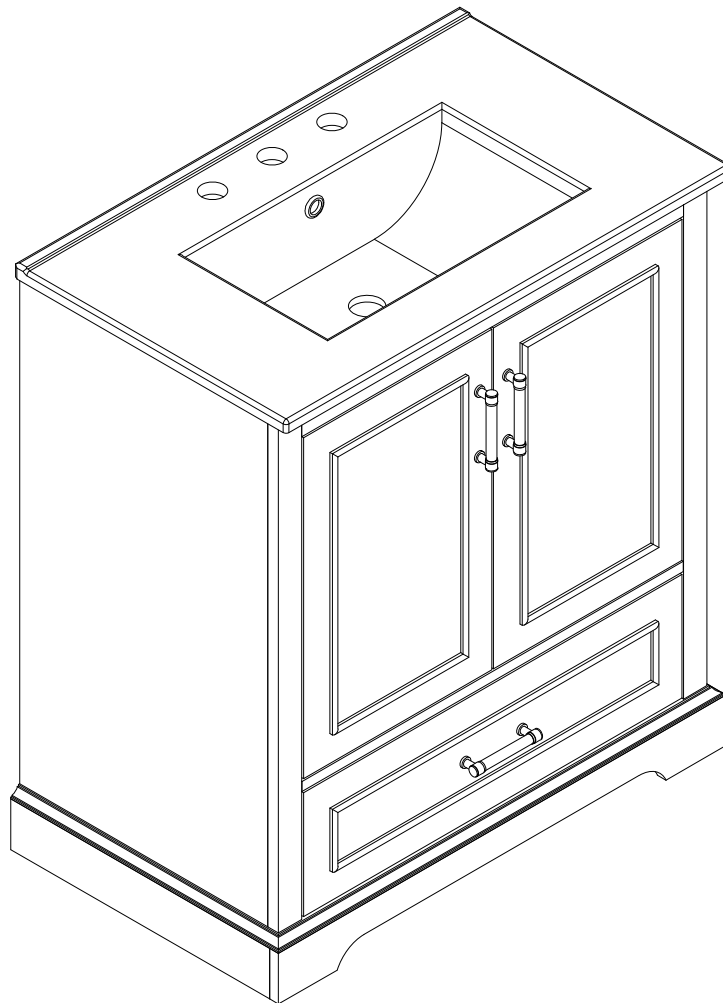

Thank you for purchasing this quality product. Be sure to check all packaging material carefully for small parts which may have come loose inside the carton during shipment. Separate, identify and count all parts and hardware. Compare with the parts list to be sure all parts are present.
"DO NOT TIGHTEN SCREWS UNTIL COMPLETELY ASSEMBLED"

Merci d'avoir acheté ce produit de qualité. Assurez-vous de vérifier soigneusement tout le matériel d'emballage pour détecter les petites pièces qui auraient pu se détacher à l'intérieur du carton pendant le transport. Séparez, identifiez et comptez toutes les pièces et le matériel. Comparez avec la liste des pièces pour vous assurer que toutes les pièces sont présentes.
"NE SERREZ PAS LES VIS AVANT D'ÊTRE COMPLÈTEMENT ASSEMBLÉES"

• Use of power tool to assemble this product will invalidate any claim and damage this product making unsafe !!!
• Please assemble on a clean soft surface to avoid damage.

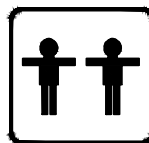
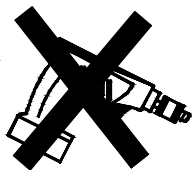

Tools Required

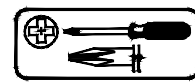

(Not Included)

IMPORTANT:

**PLEASE READ INSTRUCTION BEFORE STARTING THE ASSEMBLY
VEUILLEZ LIRE LES INSTRUCTIONS AVANT DE COMMENCER L'ASSEMBLAGE**

Before Installation

Important - Please read these instructions fully before starting assembly

Thank you for purchasing this quality product. Be sure to check all packing materials carefully for small parts, which may have come loose inside the carton during shipment. Identify and count all items according to the PARTS LIST and/or HARDWARE LIST shown below. Check you have all the components and tools listed on the following pages.

- . We recommend that you assemble this product with the assistance of another person; this will make the assembly easier, and will help eliminate damage to the product or injury to persons during assembly.
- . Please do not over tighten screws or bolts until the assembly is completed.
- . Keep children and animal away from the work area, small parts could choke if swallowed.
- . Please put all parts on a non-abrasive floor before assembly, and follow the assembly steps to assemble your newly purchased product correctly and efficiently.

If you find that you have any trouble with assembly or missing or damaged parts please contact the seller.

Cam Lock Assembly Instructions

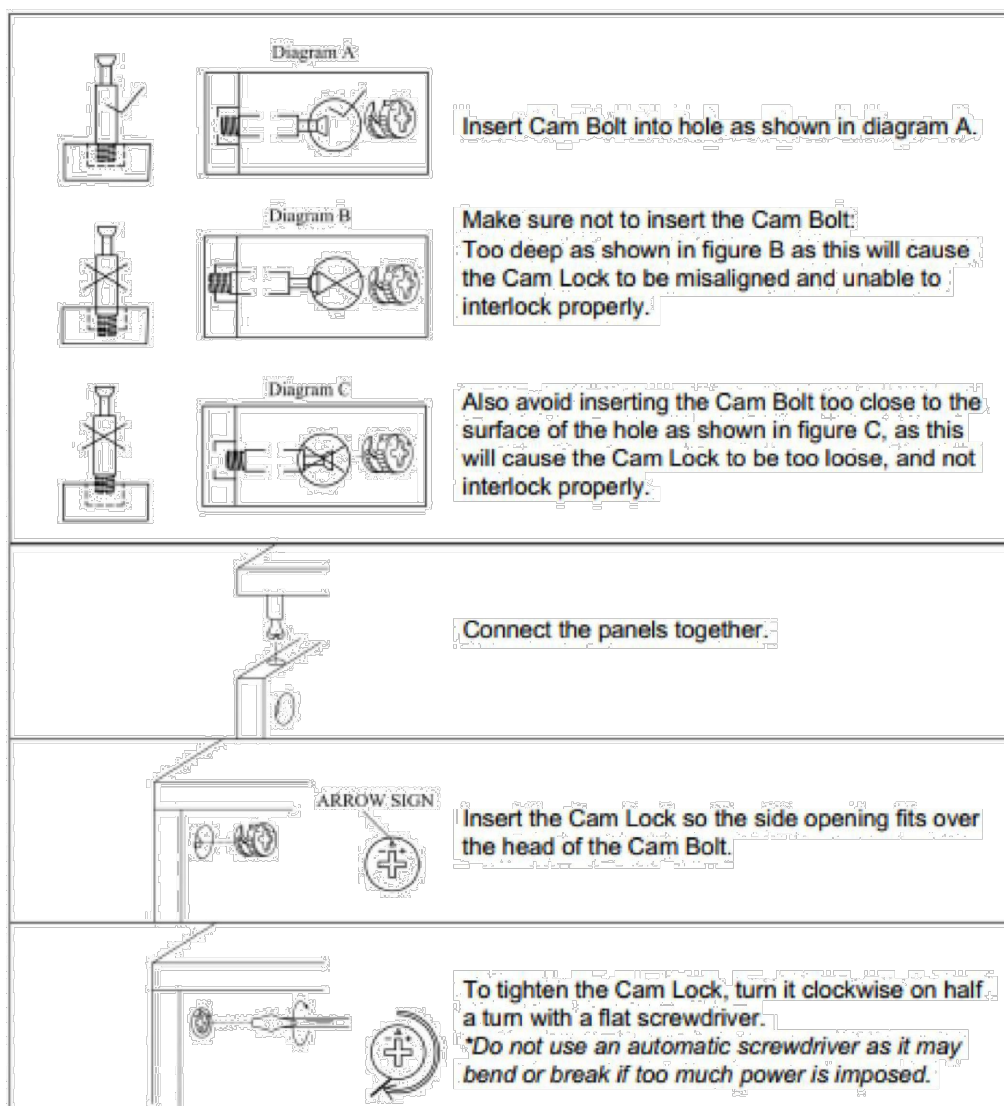

Before Installation

Important - Veuillez lire entièrement ces instructions avant de commencer l'assemblage.

Merci d'avoir acheté ce produit de qualité. Assurez-vous de vérifier soigneusement tous les matériaux d'emballage pour détecter les petites pièces qui pourraient s'être détachées à l'intérieur du carton pendant le transport. Identifiez et comptez tous les éléments conformément à la LISTE DES PIÈCES et/ou à la LISTE DU MATÉRIEL indiquée ci-dessous. Vérifiez que vous disposez de tous les composants et outils répertoriés dans les pages suivantes.

- Nous vous recommandons d'assembler ce produit avec l'aide d'une autre personne ; cela facilitera l'assemblage et aidera à éliminer les dommages au produit ou les blessures corporelles pendant l'assemblage.

- Veuillez ne pas trop serrer les vis ou les boulons jusqu'à ce que l'assemblage soit terminé.

- Tenir les enfants et les animaux éloignés de la zone de travail, les petites pièces pourraient s'étouffer en cas d'ingestion.

- Veuillez placer toutes les pièces sur un sol non abrasif avant l'assemblage et suivre les étapes d'assemblage pour assembler correctement et efficacement votre produit nouvellement acheté.

Si vous constatez des problèmes d'assemblage ou des pièces manquantes ou endommagées, veuillez contacter le vendeur.

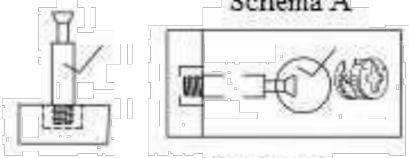
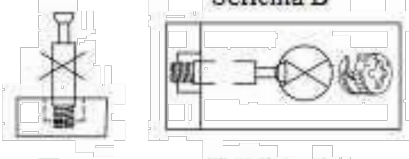
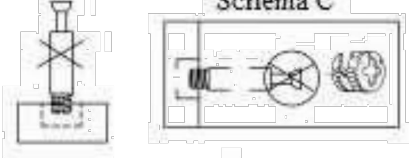
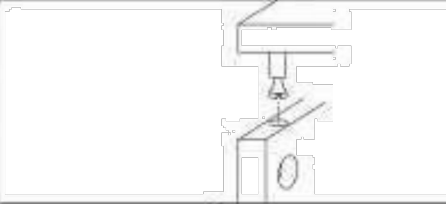
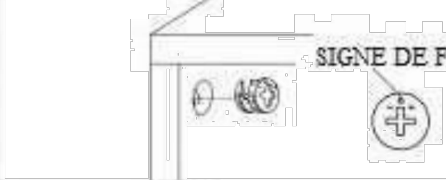
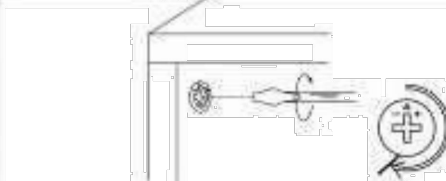

Instructions d'assemblage du verrou à came

	<p>Schéma A</p> <p>Insérez le boulon à came dans le trou comme indiqué sur le schéma A.</p>
	<p>Schéma B</p> <p>Assurez-vous de ne pas insérer le boulon à came trop profond, comme indiqué sur la figure B, car cela entraînerait un mauvais alignement du Cam Lock et son incapacité à se verrouiller correctement.</p>
	<p>Schéma C</p> <p>Évitez également d'insérer le boulon à came trop près de la surface du trou, comme indiqué sur la figure C, car cela rendrait le verrou à came trop lâche et ne s'emboîterait pas correctement.</p>
	<p>Connectez les panneaux ensemble.</p>
	<p>SIGNE DE FLÈCHE</p> <p>Insérez le verrou à came de manière à ce que l'ouverture latérale s'ajuste sur la tête du boulon à came.</p>
	<p>Pour serrer le Cam Lock, tournez-le d'un demi-tour dans le sens des aiguilles d'une montre à l'aide d'un tournevis plat.</p> <p>*N'utilisez pas de tournevis automatique car il pourrait se plier ou se casser si trop de puissance</p>

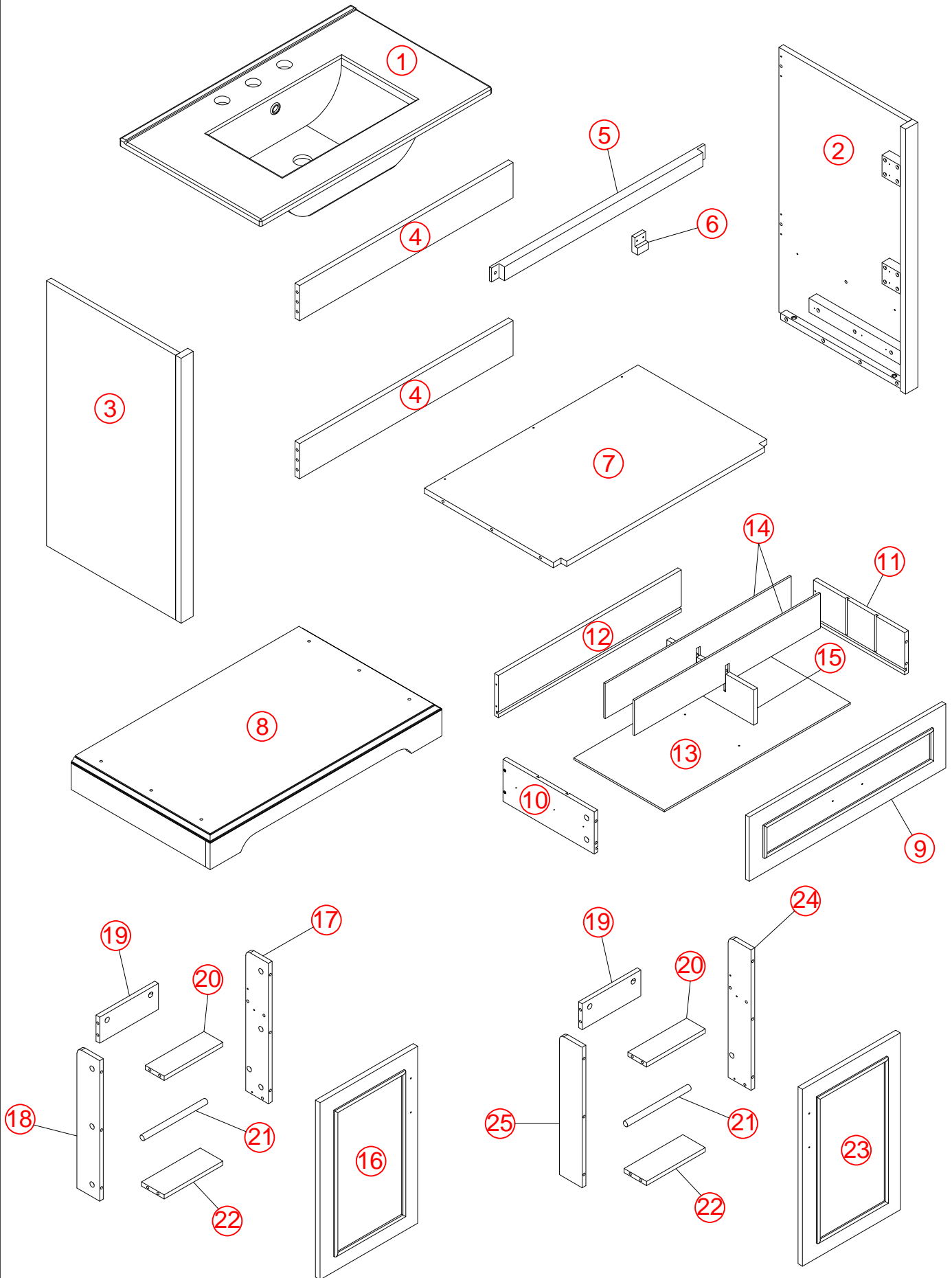



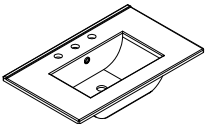
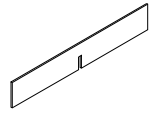
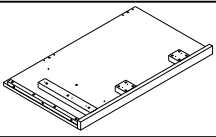
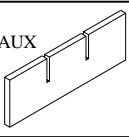
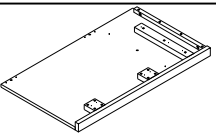
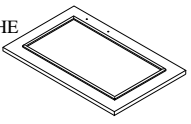
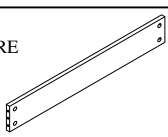
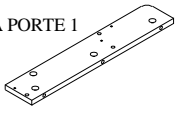
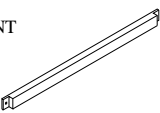
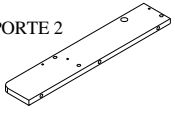

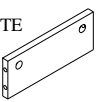
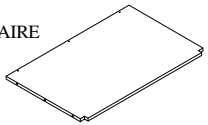
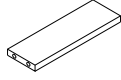
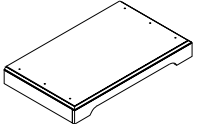
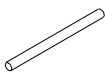
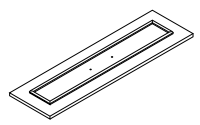
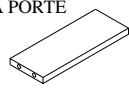
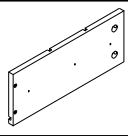
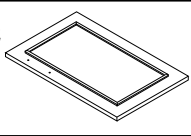
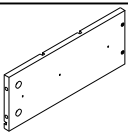
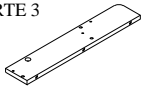
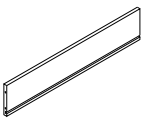
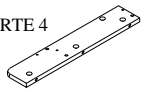
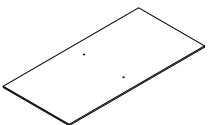



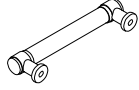



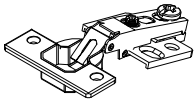

PRODUCT DETAILS
DÉTAILS DU PRODUIT

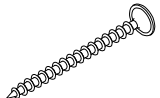

PARTS LIST
LISTE DES PIÈCES

①	SINK (LAVABO) ÉVIER (LAVABO)		1PC	⑭	DRAWER DIVIDERS SÉPARATEURS DE TIROIRS		2PCS
②	RIGHT HIP HANCHE DROITE		1PC	⑮	VERTICAL DRAWER DIVIDERS SÉPARATEURS DE TIROIRS VERTICAUX		1PC
③	LEFT FEET PIEDS GAUCHE		1PC	⑯	LEFT DOOR PANEL PANNEAU DE PORTE GAUCHE		1PC
④	REAR CROSSBAR BARRE TRANSVERSALE ARRIÈRE		2PCS	⑰	HIP STANDING IN DOOR 1 HANCHE DEBOUT DANS LA PORTE 1		1PC
⑤	FRONT CROSSBAR BARRE TRANSVERSALE AVANT		1PC	⑱	HIP STANDING IN DOOR 2 HANCHE DEBOUT DANS LA PORTE 2		1PC
⑥	DOOR STOPPER BUTOIR DE PORTE		1PC	⑲	VERTICAL PANEL IN DOOR PANNEAU VERTICAL DANS LA PORTE		2PCS
⑦	MIDDLE FLOOR PLAN PLAN D'ÉTAGE INTERMÉDIAIRE		1PC	⑳	HORIZONTAL SHELF DOOR BOARD PANNEAU DE PORTE D'ÉTAGÈRE HORIZONTALE		2PCS
⑧	BOTTOM BOARD PLANCHE INFÉRIEURE		1PC	㉑	CIRCLE CERCLE		2PCS
⑨	DRAWER FACE FACE DE TIROIR		1PC	㉒	HORIZONTAL BOARD UNDER DOOR SHELF ÉTAGÈRE HORIZONTALE SOUS LA PORTE		2PCS
⑩	LEFT SIDE OF DRAWER CÔTÉ GAUCHE DU TIROIR		1PC	㉓	RIGHT DOOR PANEL PANNEAU DE PORTE DROITE		1PC
⑪	RIGHT SIDE OF DRAWER CÔTÉ DROITE DU TIROIR		1PC	㉔	HIP STANDING IN DOOR 3 HANCHE DEBOUT DANS LA PORTE 3		1PC
⑫	DRAWER BACK FOND DE TIROIR		1PC	㉕	HIP STANDING IN DOOR 4 HANCHE DEBOUT DANS LA PORTE 4		1PC
⑬	DRAWER BOTTOM FOND DE TIROIR		1PC				

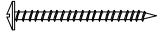
HARDWARE LIST
LISTE DU MATÉRIEL



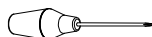

(A)	A1 : D300MM 	2SET	(J)	L110MM 	3PCS
	A2 : D300MM 				
(B)	3.5*10MM 	12PCS	(K)	M4*20MM 	6PCS
(C)	Ø5*35 	40PCS	(L)	Ø 35 	4PCS
(D)	Ø 8 * 30MM 	8PCS	(M)	3.5*15MM 	26PCS
(E)	Ø 15*10MM 	40PCS	(N)	Ø 6 * 30MM 	12PCS
(F)	M4*30MM 	5PCS	(O)	M4*50MM 	4PCS
(G)	M6*20MM 	2PCS	(P)	Ø 10*10MM 	4PCS
(H)	L4*58MM 	1PC	(Q)	 	2SET
(I)	M6*25MM 	4PCS			

ASSEMBLY TOOLS REQUIRED (NOT INCLUDED)
OUTILS D'ASSEMBLAGE REQUIS (NON INCLUS)

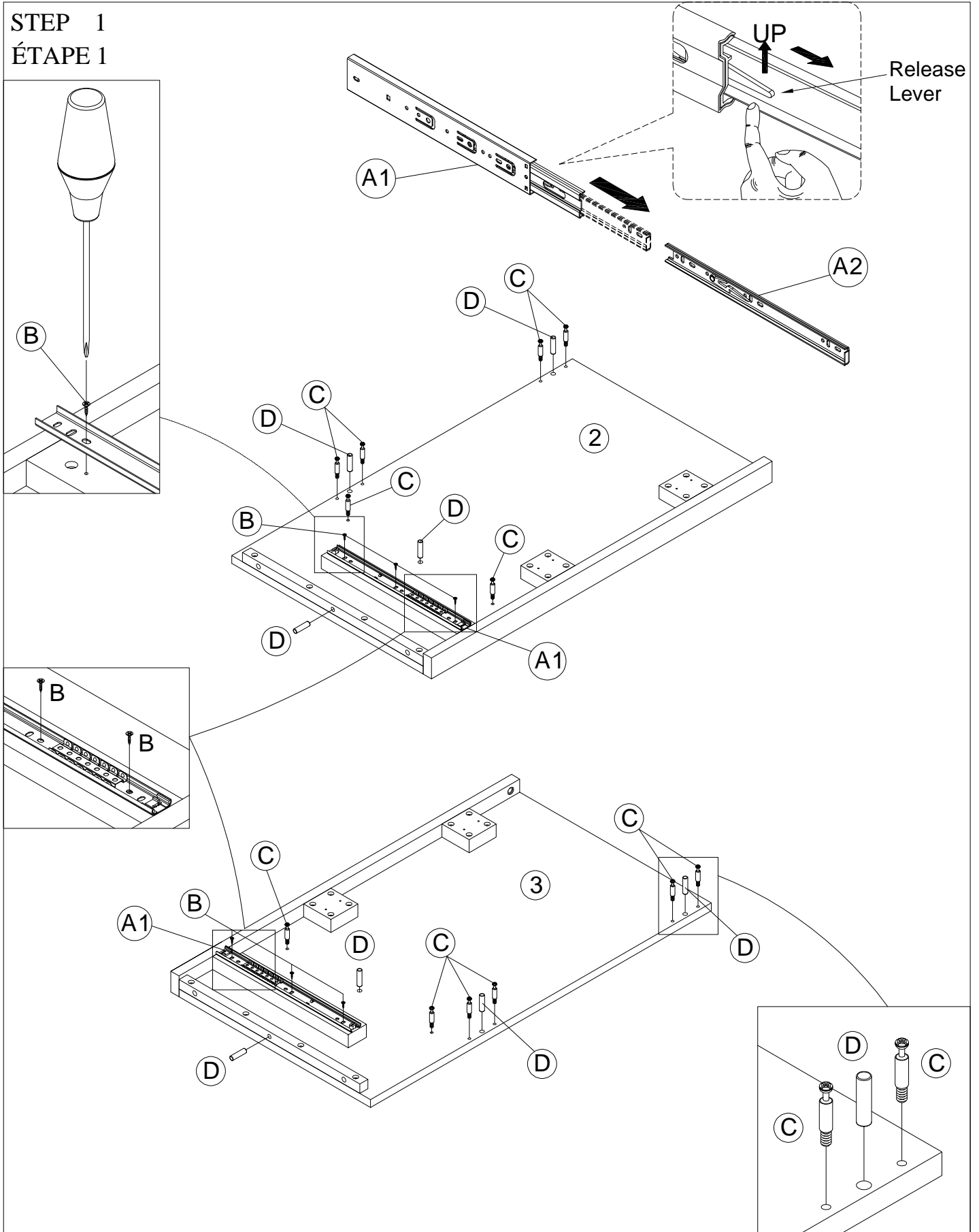

STEP 1
ÉTAPE 1



Ⓐ	L45*300MM 	2PCS	Ⓑ	3.5*10MM 	6PCS
Ⓒ	Ø5*35MM 	12PCS	Ⓓ	Ø 8 * 30MM 	8PCS

STEP 2
ÉTAPE 2

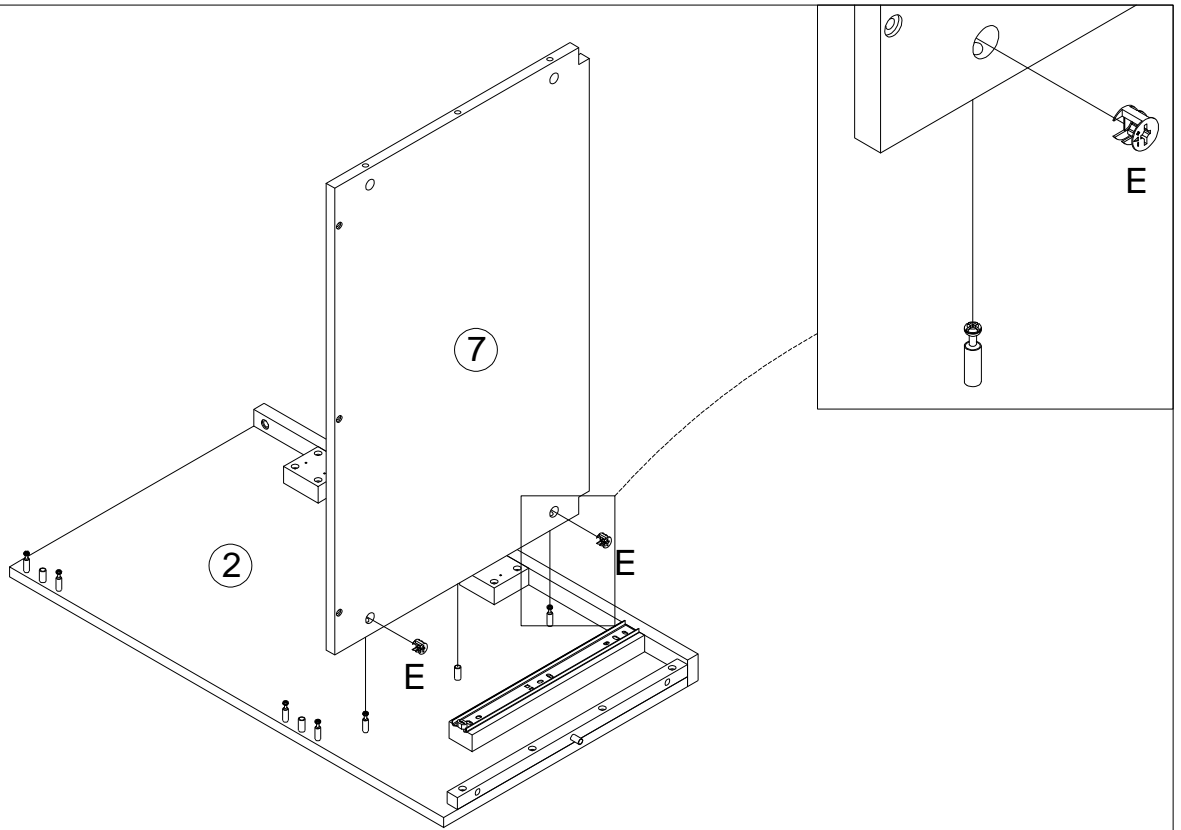

ⓔ	Ø 15		2PCS
---	------	--	------

STEP 3
ÉTAPE 3

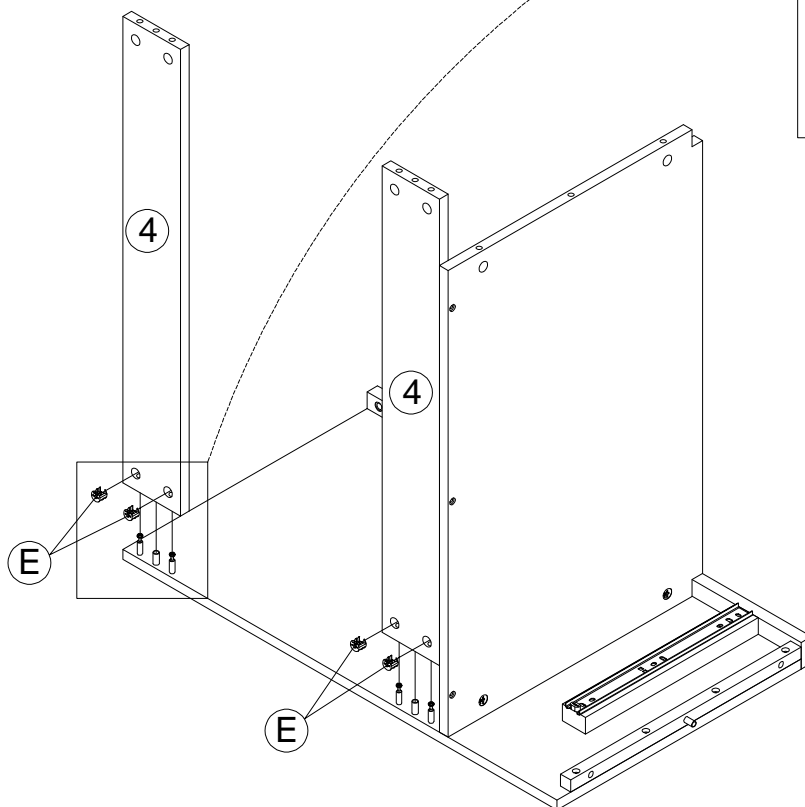

ⓔ	Ø 15		4PCS
---	------	---	------

STEP 4
ÉTAPE 4

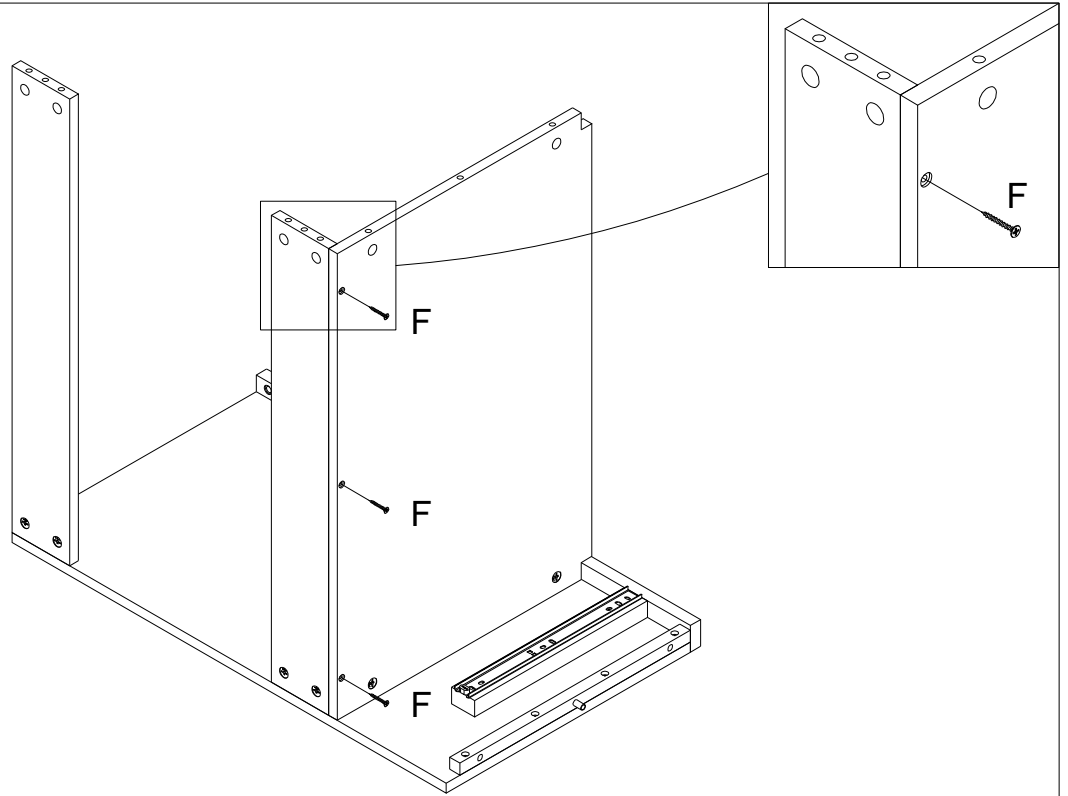

ⓕ	M4*30MM		3PCS
---	---------	--	------

STEP 5
ÉTAPE 5

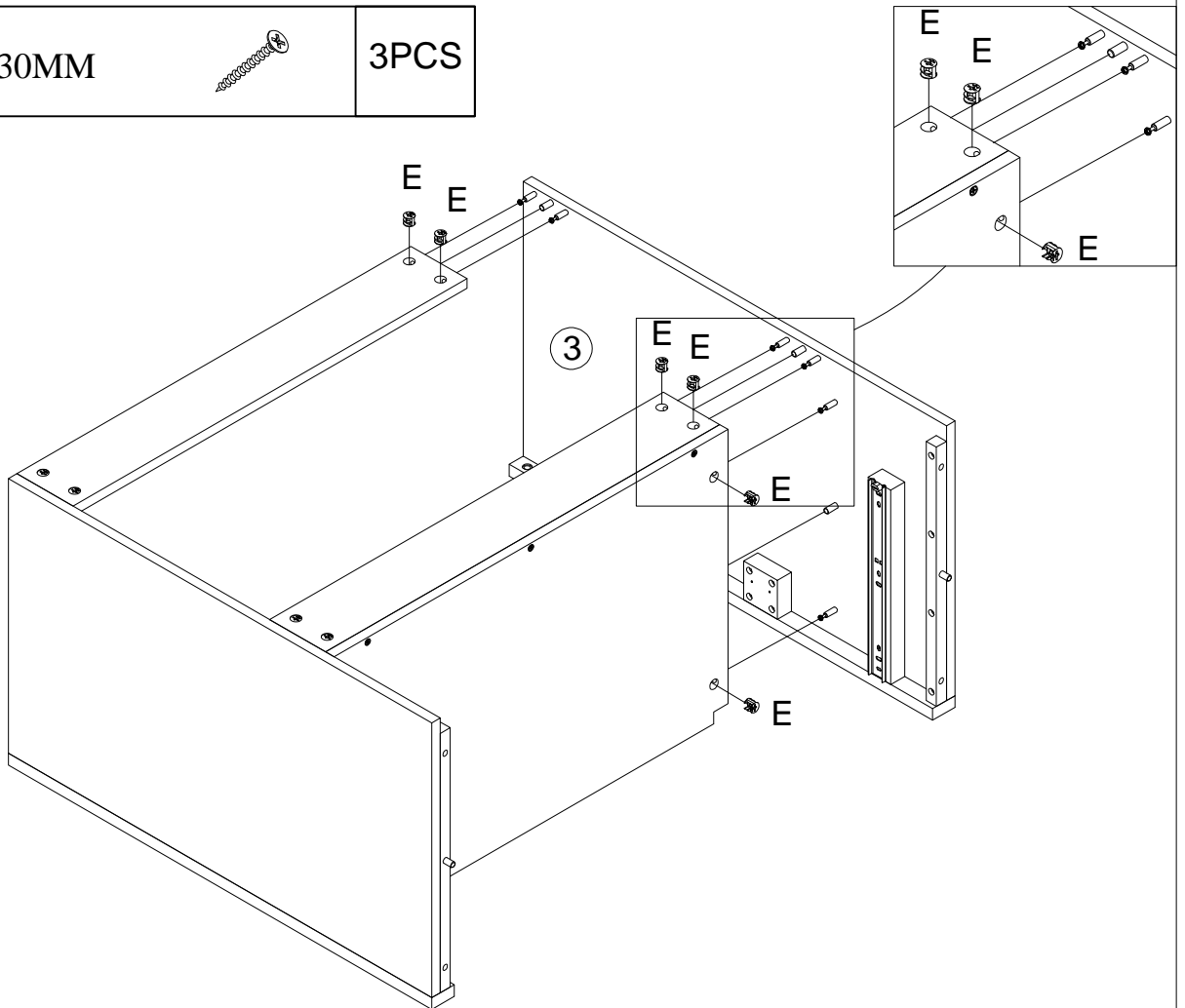

ⓔ	Ø 15		6PCS
---	------	---	------

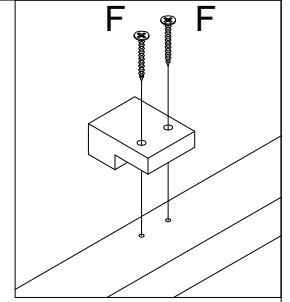
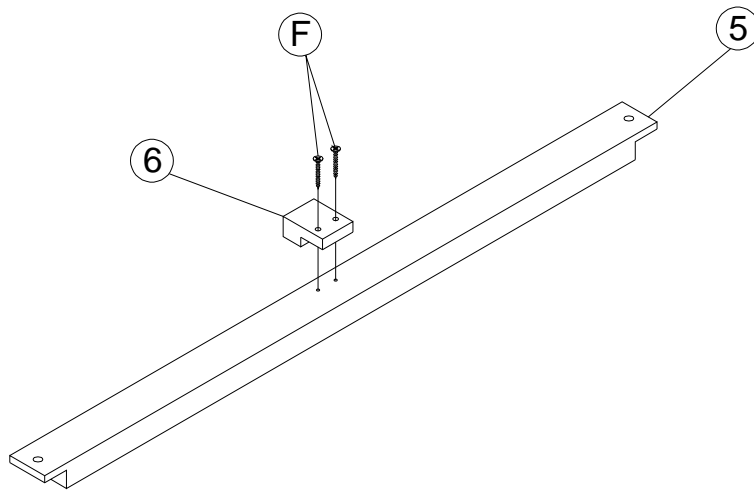

STEP 6
ÉTAPE 6

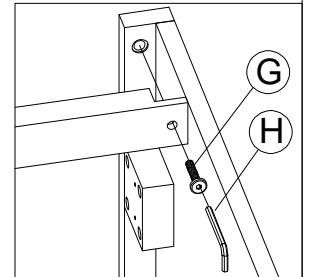
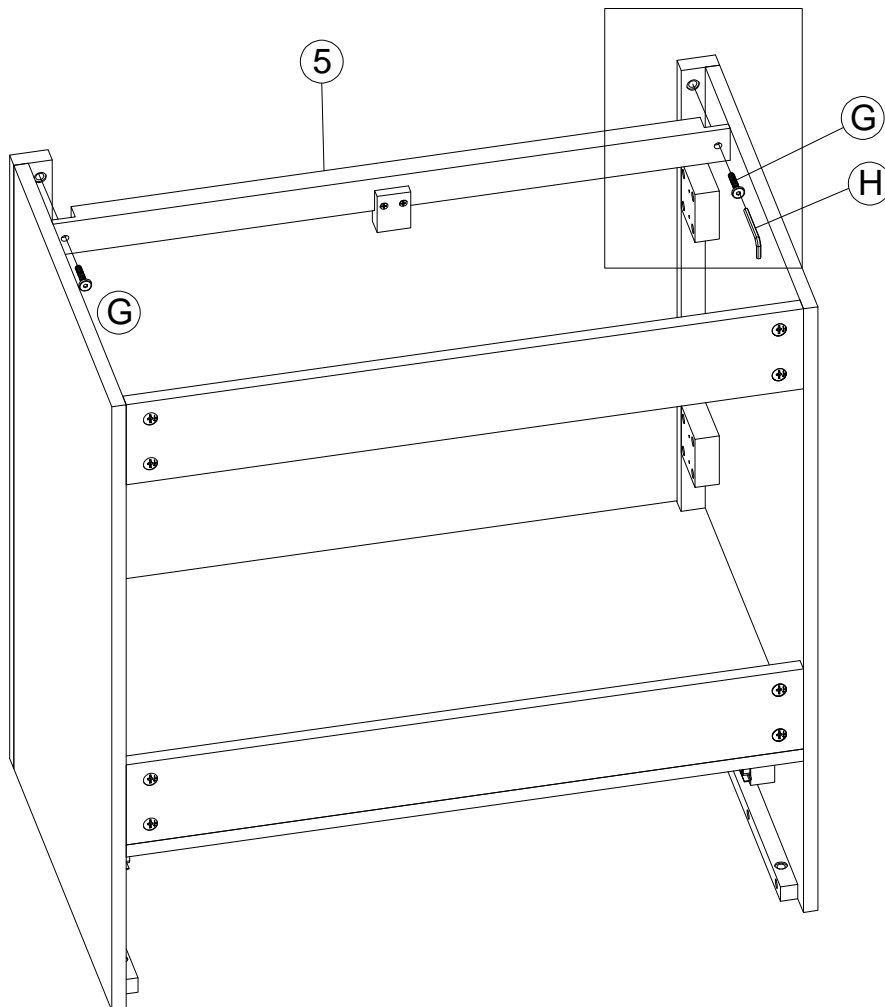

ⓕ	M4*30MM		2PCS
---	---------	---	------

STEP 7
ÉTAPE 7



ⓐ	M6*20MM		2PCS	ⓓ	L4*58MM		1PC
---	---------	---	------	---	---------	---	-----

STEP 8
ÉTAPE 8

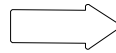
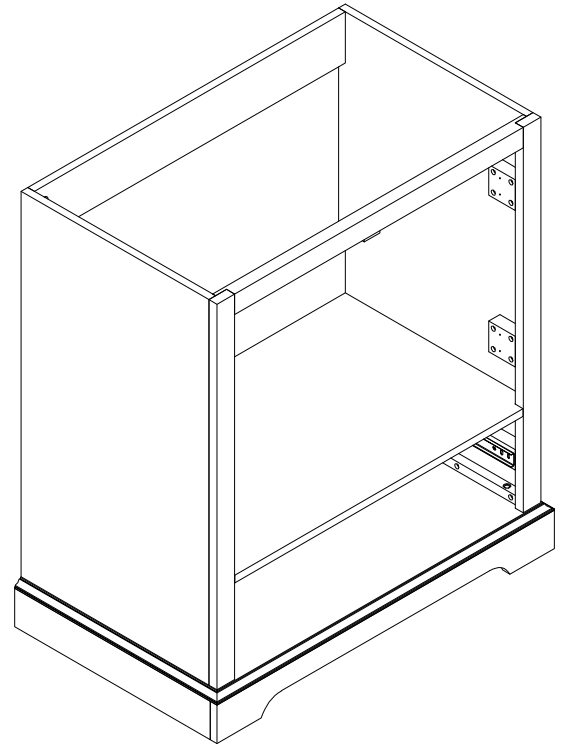
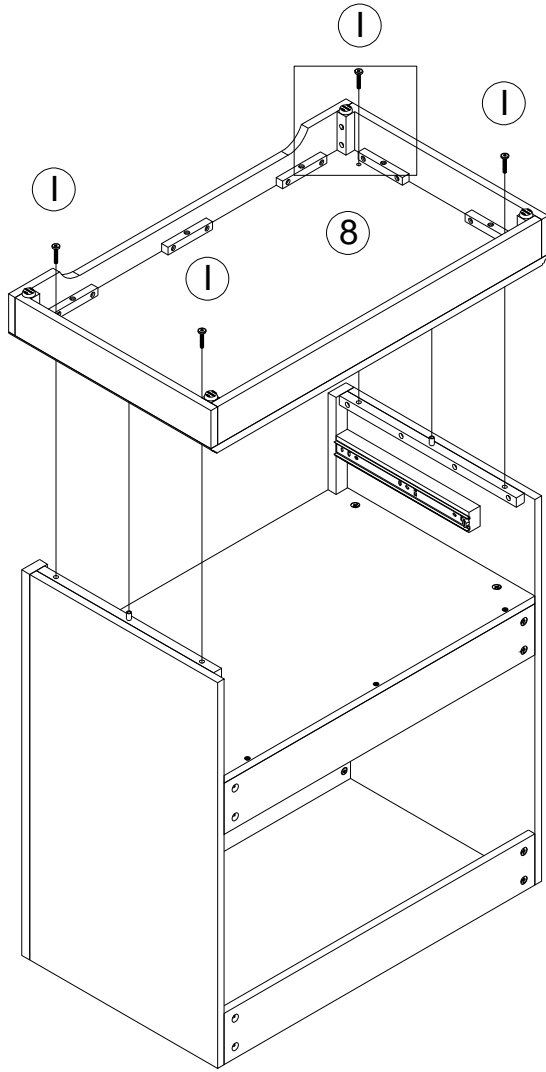
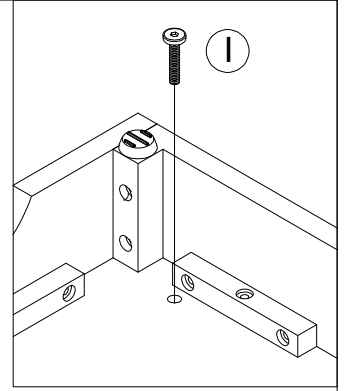

①	M6*25MM		4PCS
---	---------	---	------

STEP 9
ÉTAPE 9

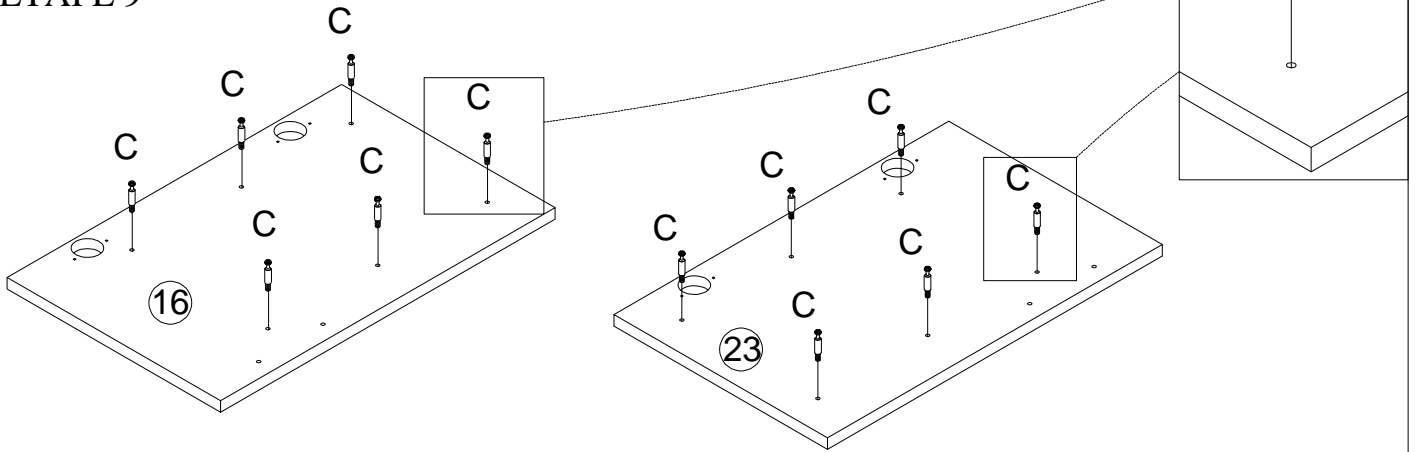

C	Ø5*35MM	12PCS
---	---------	-------

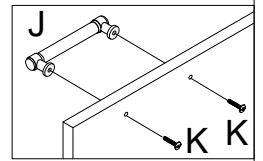

STEP 10
ÉTAPE 10

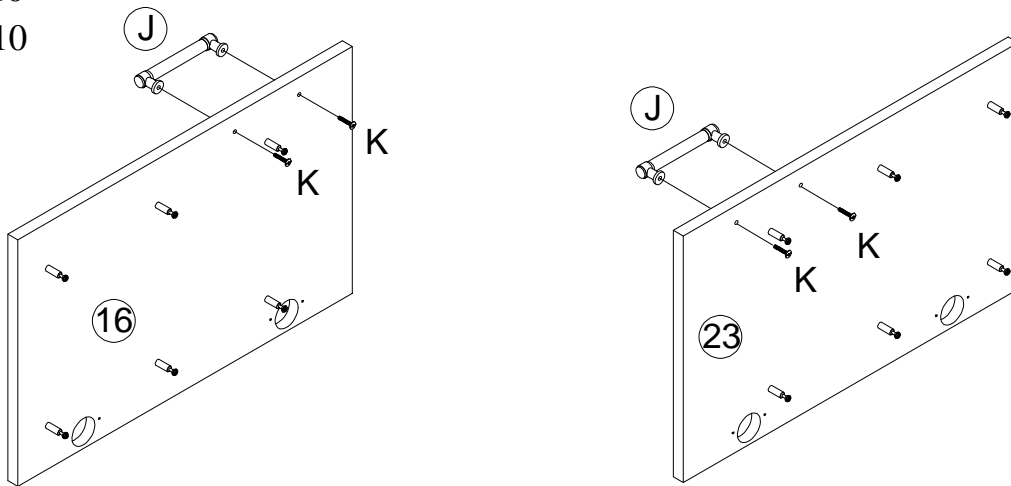

J	L110MM	2PCS
---	--------	------

K	M4*20MM	4PCS
---	---------	------

STEP 11
ÉTAPE 11

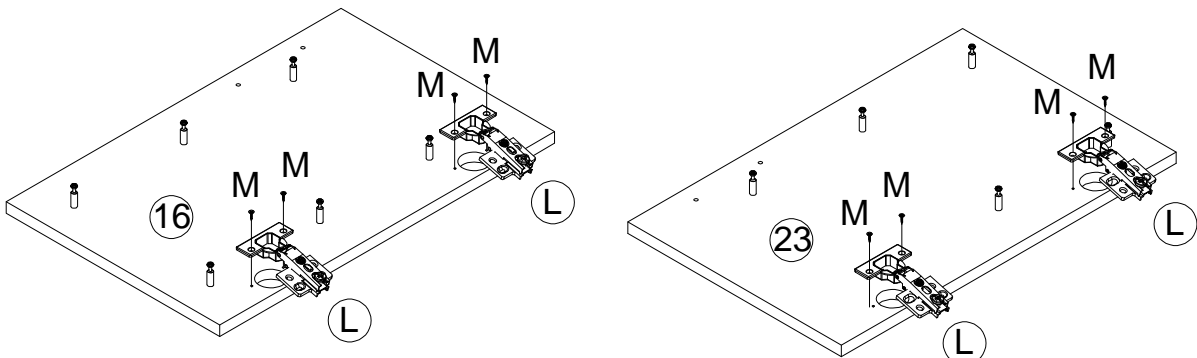

L	Ø 35	4PCS
---	------	------

M	3.5*15MM	8PCS
---	----------	------

STEP 12
ÉTAPE 12

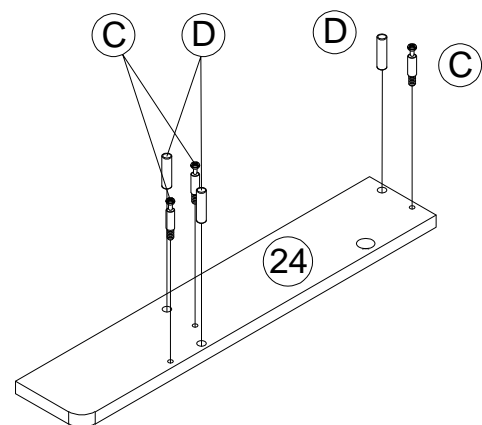
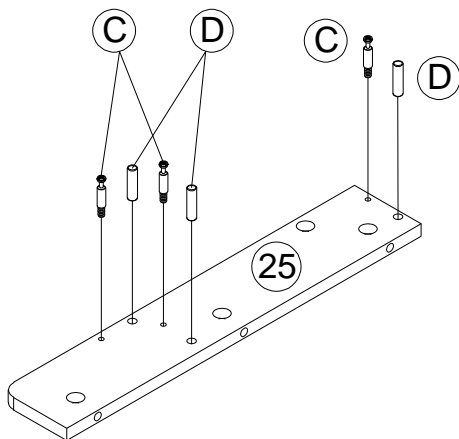
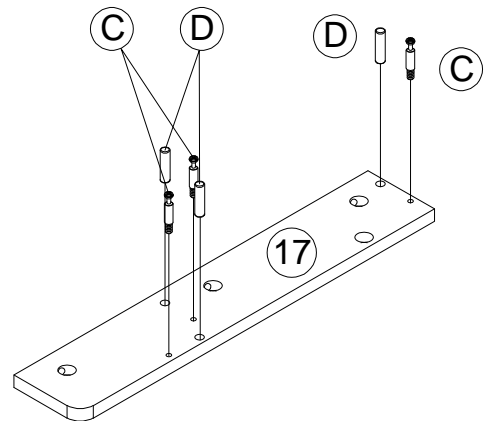
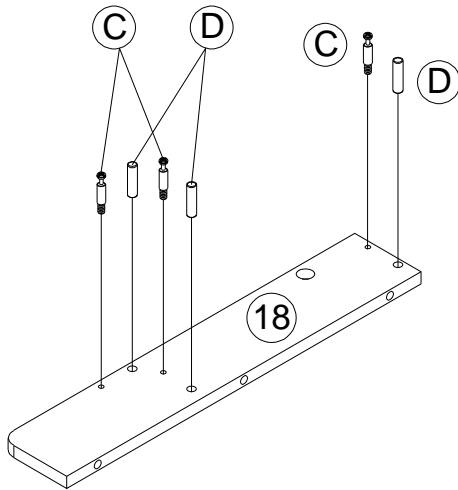
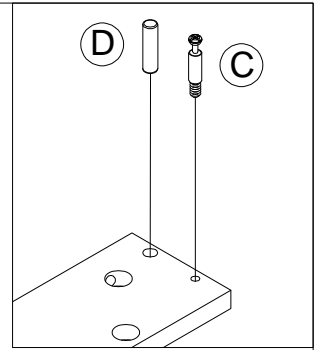

	Ø5*35MM 12PCS		Ø 6 * 30MM 12PCS
--	------------------	--	---------------------

STEP 13
ÉTAPE 13

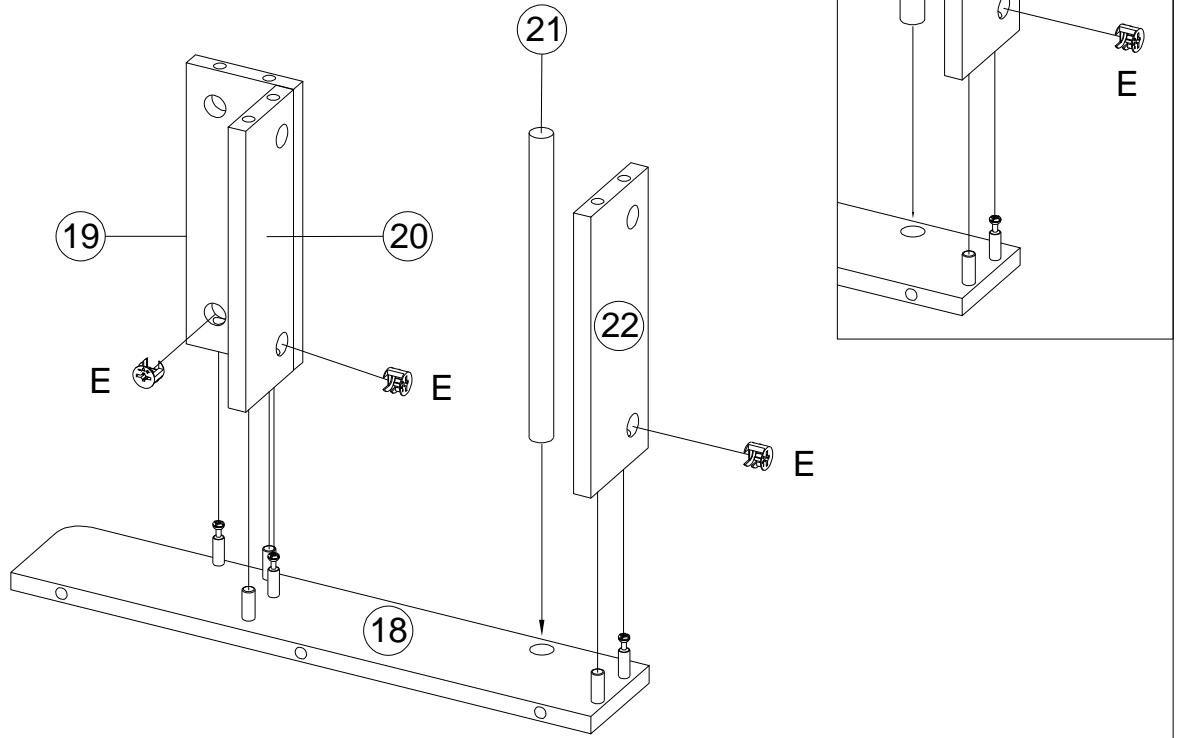

Ⓔ	Ø 15		3PCS
---	------	--	------

STEP 14
ÉTAPE 14

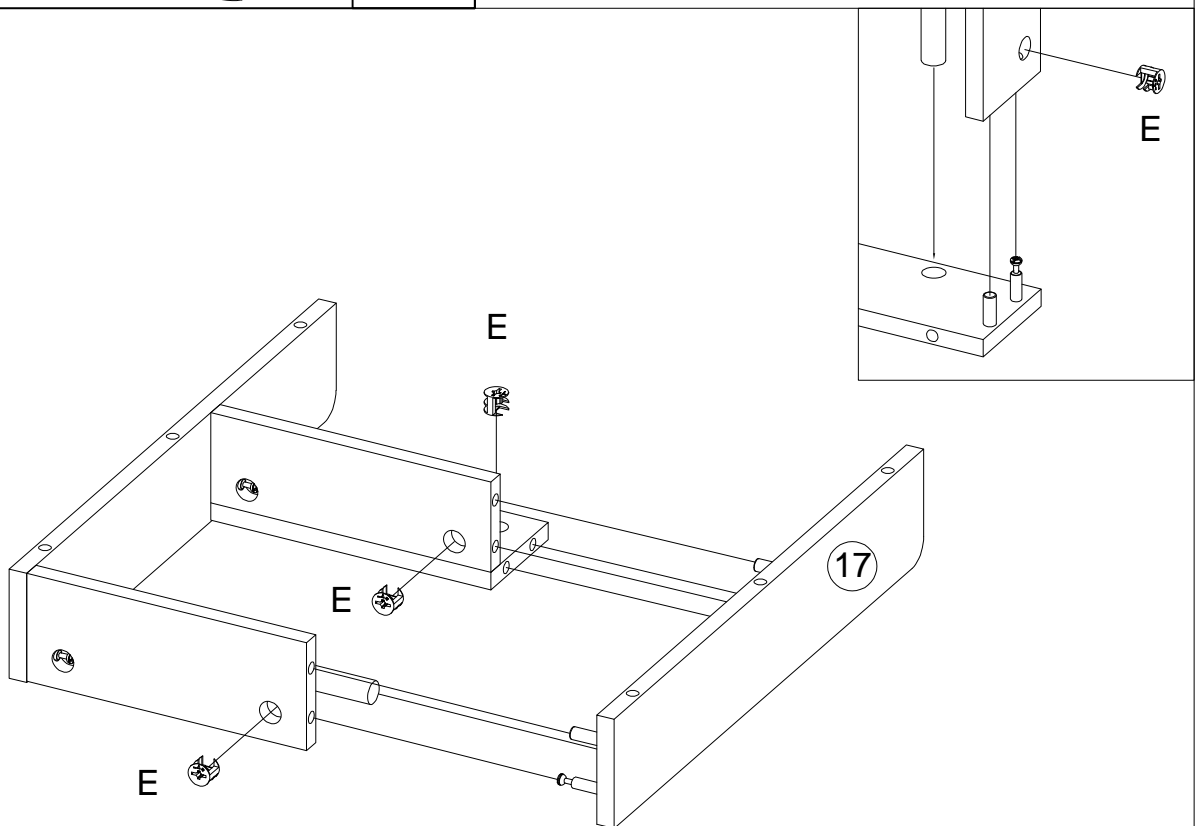

Ⓔ	Ø 15		3PCS
---	------	--	------

STEP 15
ÉTAPE 15

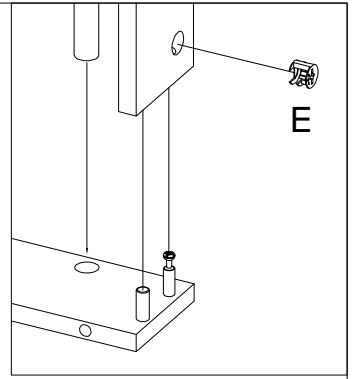
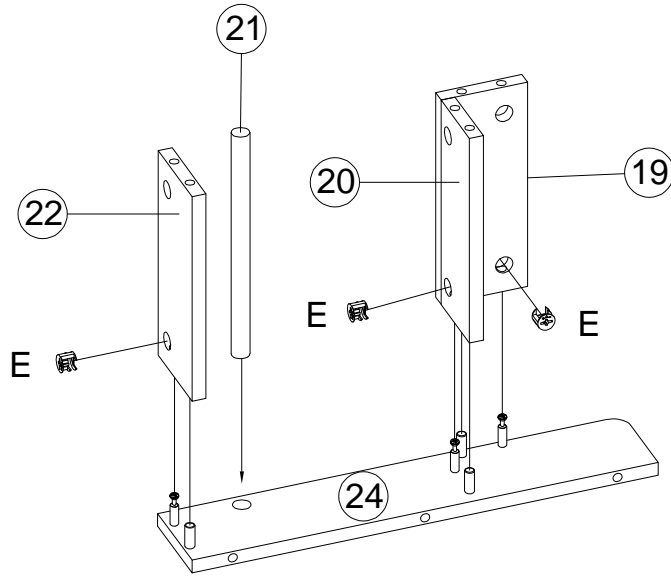

Ⓔ	Ø 15		3PCS
---	------	---	------

STEP 16
ÉTAPE 16

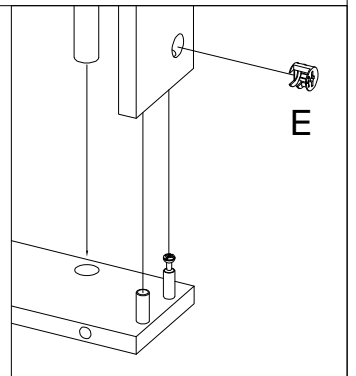
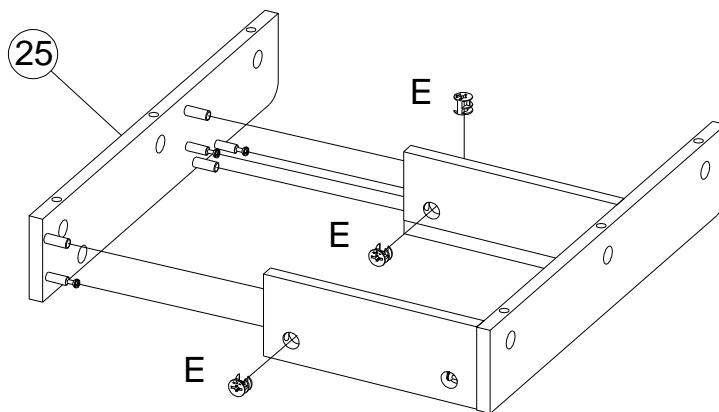

Ⓔ	Ø 15		3PCS
---	------	---	------

STEP 17
ÉTAPE 17

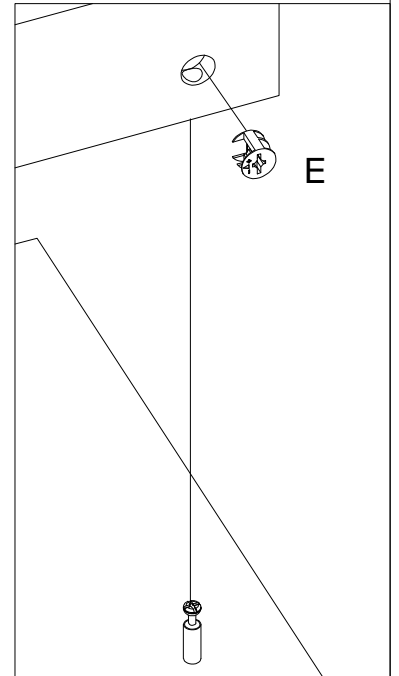
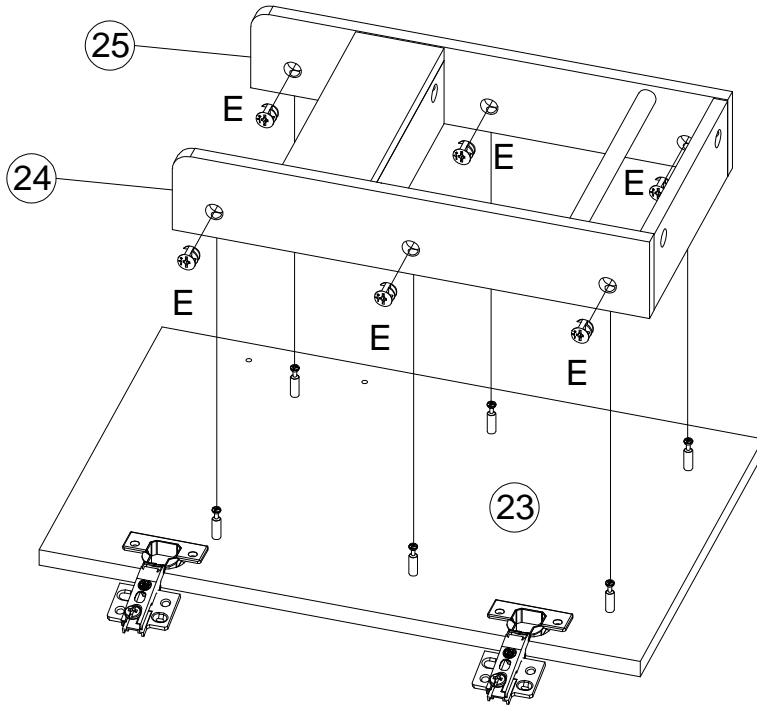

E	Ø 15		6PCS
---	------	---	------

STEP 18
ÉTAPE 18

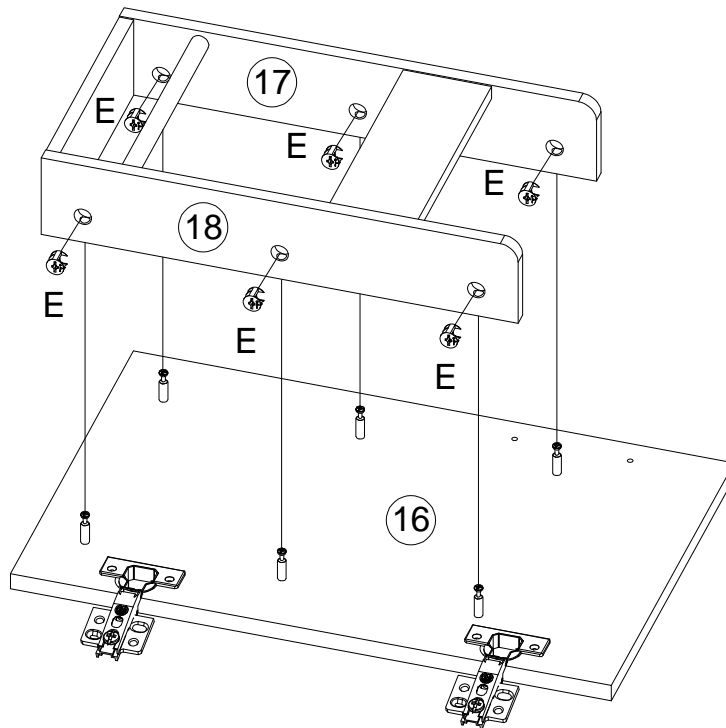

E	Ø 15		6PCS
---	------	---	------

STEP 19
ÉTAPE 19

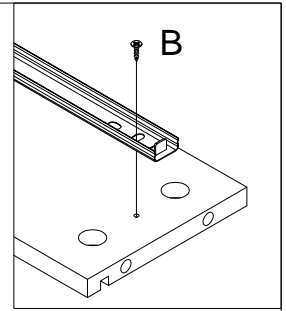
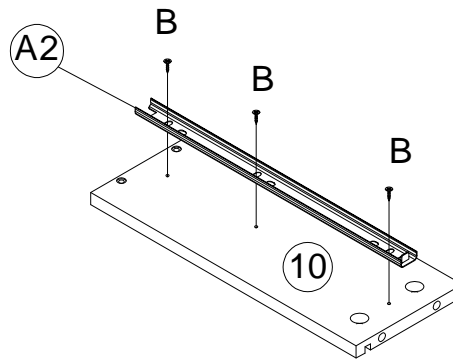
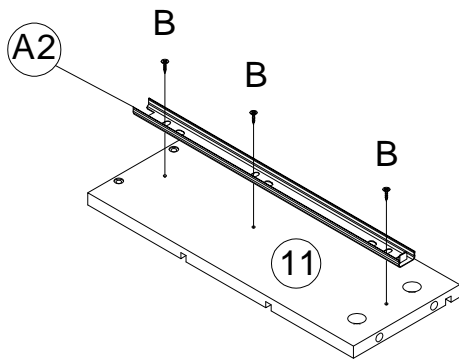

(A)	L45*300MM		2PCS
-----	-----------	---	------

(B)	3.5*10MM		6PCS
-----	----------	---	------

STEP 20
ÉTAPE 20

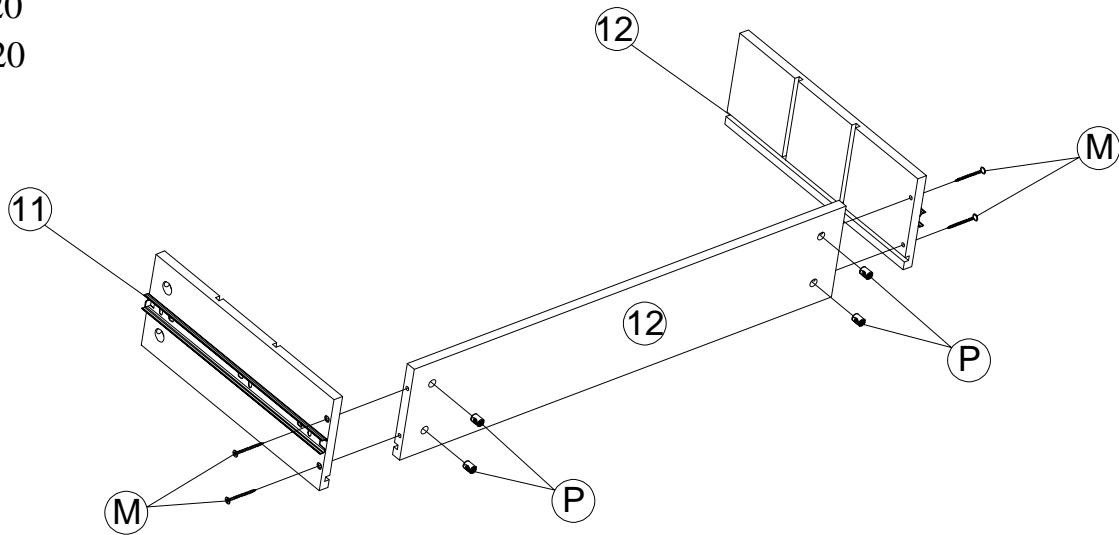



(O)	M4*50MM		4PCS
-----	---------	---	------

(P)	Ø 10*10MM		4PCS
-----	-----------	---	------

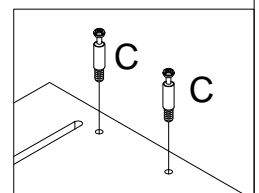
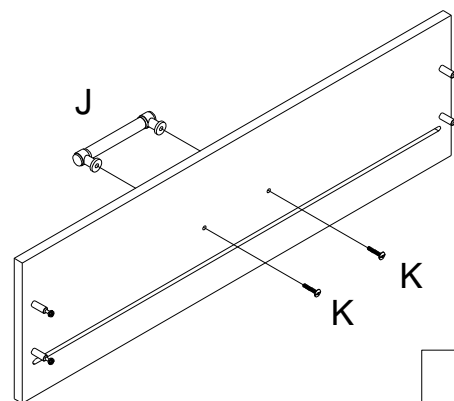
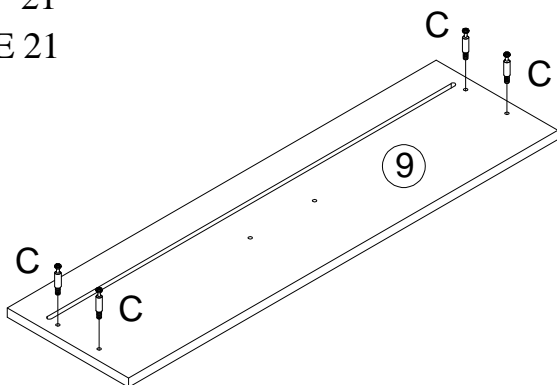
STEP 21
ÉTAPE 21



(C)	Ø5*35MM		4PCS
-----	---------	---	------

(J)	L110MM		1PCS
-----	--------	---	------

(K)	M4*20MM		2PCS
-----	---------	---	------

STEP 22
ÉTAPE 22

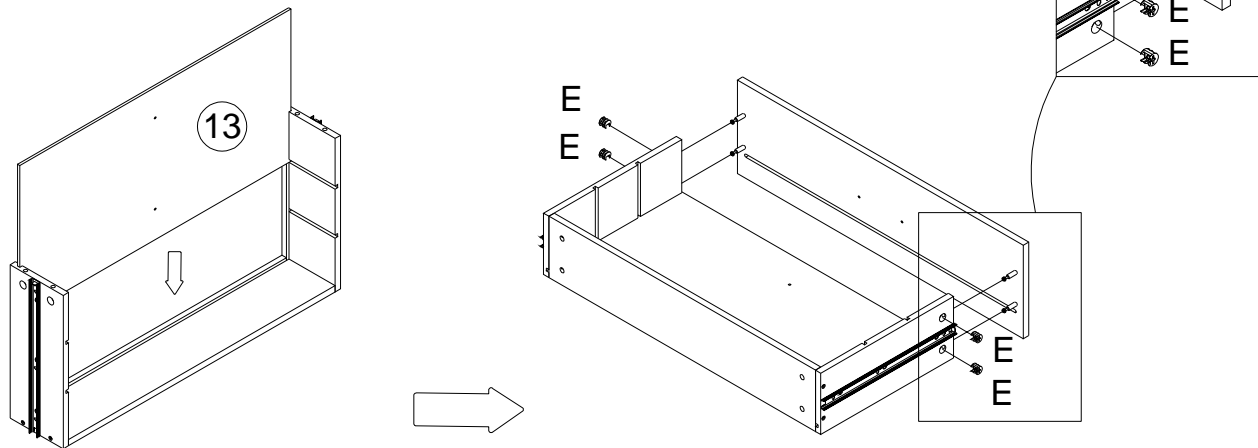

E	Ø 15		4PCS
---	------	---	------

STEP 23
ÉTAPE 23

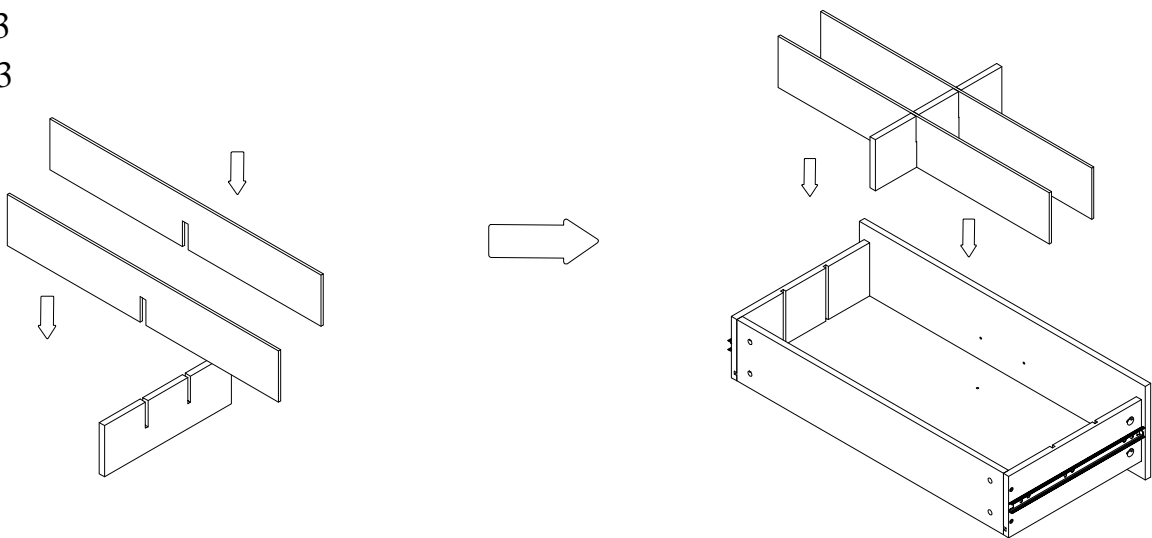

M	3.5*15MM		2PCS
---	----------	---	------

STEP 24
ÉTAPE 24

Three-way adjustable hinge for perfectly aligned doors
 1. TO ADJUST DOOR FORWARD OR BACKWARD.
 2. TO ADJUST DOOR TO RIGHT OR TO LEFT.
 3. TO ADJUST DOOR UP OR DOWN.

Charnière réglable à trois voies pour des portes parfaitement alignées
 1. POUR RÉGLER LA PORTE VERS L'AVANT OU VERS L'ARRIÈRE.
 2. POUR RÉGLER LA PORTE À DROITE OU À GAUCHE.
 3. POUR RÉGLER LA PORTE VERS LE HAUT OU VERS LE BAS.

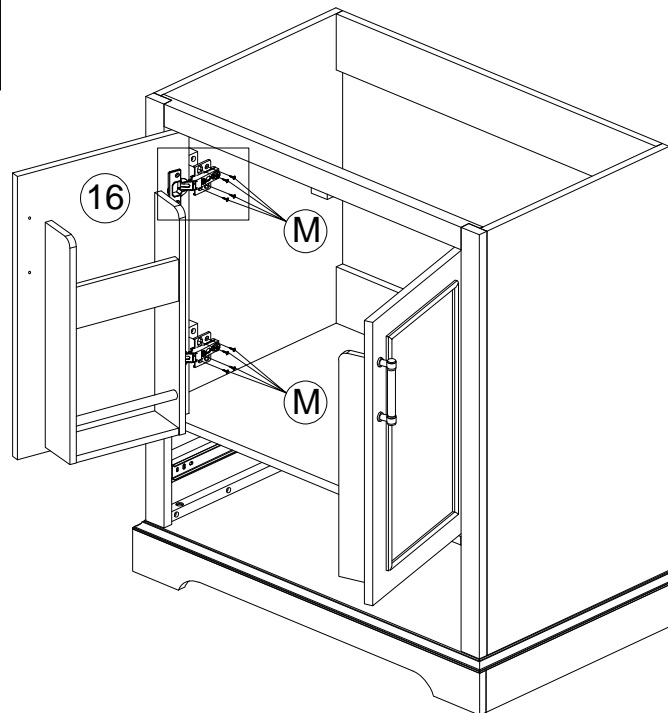
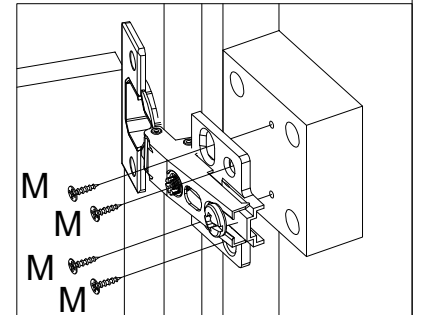
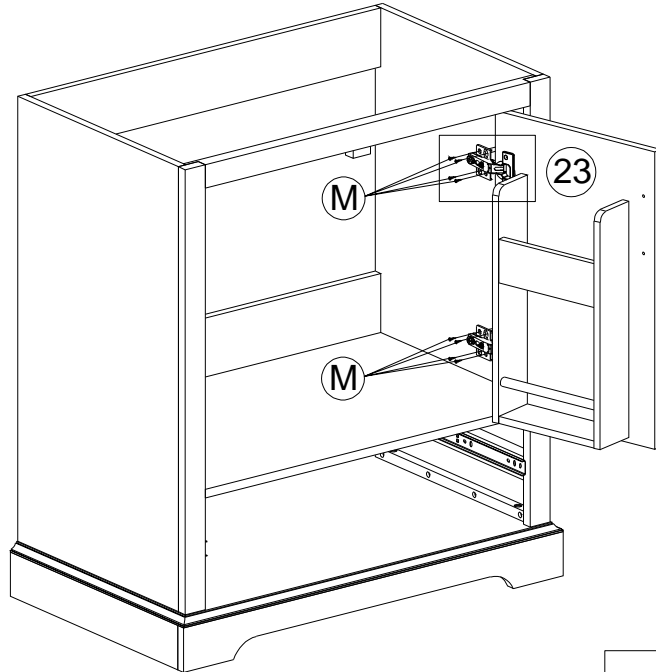
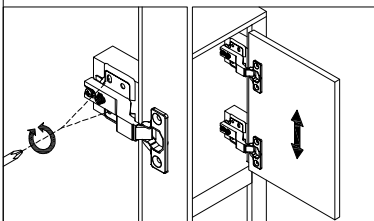
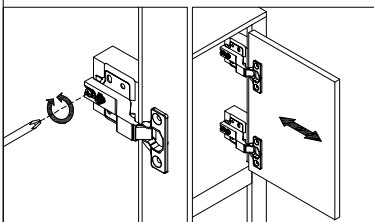
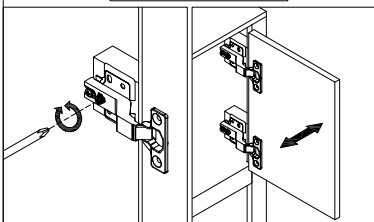
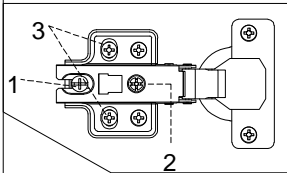

	3.5*15MM	16PCS
--	----------	-------

STEP 25
ÉTAPE 25

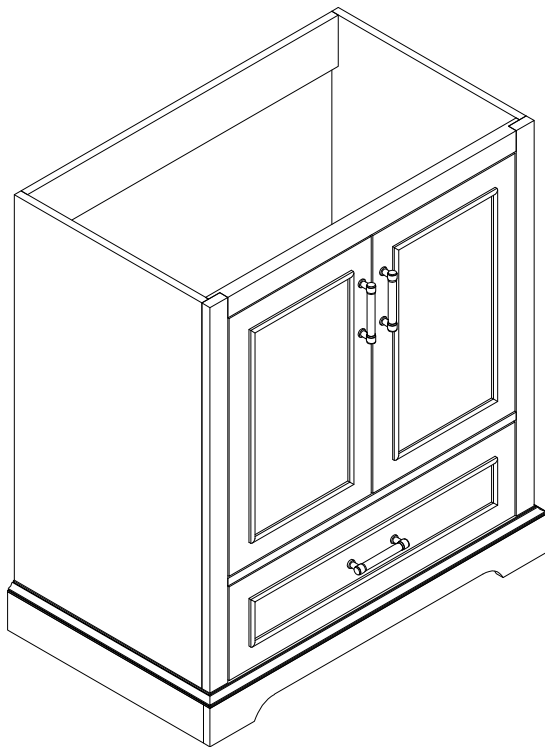
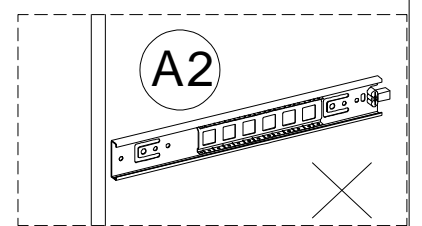
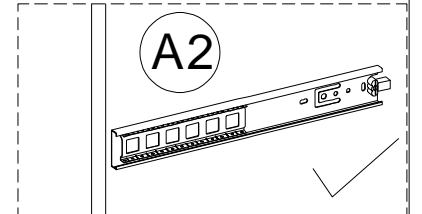
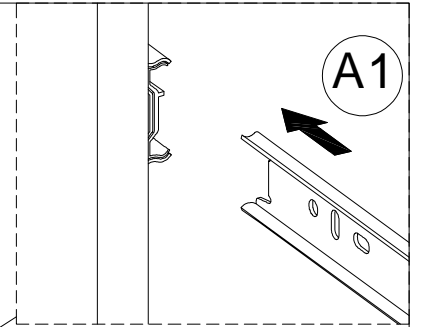
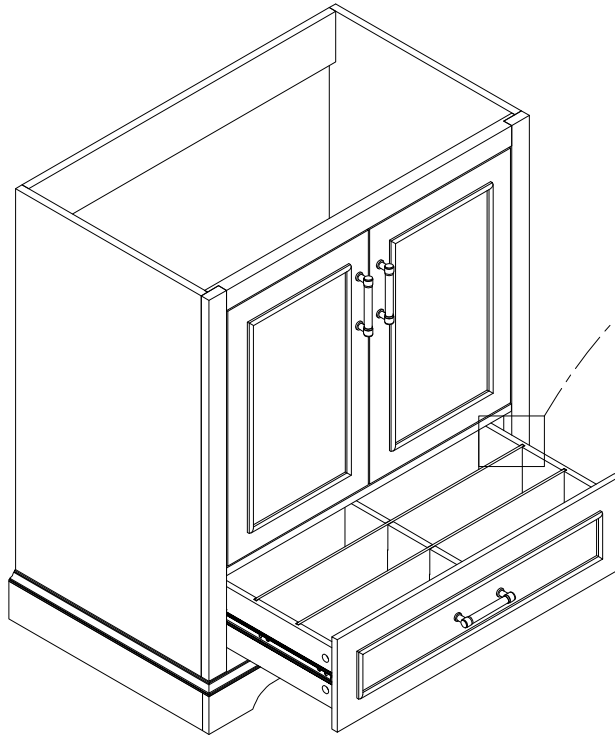

STEP 26

ÉTAPE 26

To install the Top (1) to the vanity (2).

Apply silicone caulk to the top edge of the wood cabinet. With the help of another adult, gently lower the Sink top with assembled sink onto the cabinet. Make sure the Sink top is flush with the back side of the wood cabinet and the wood cabinet left and right side walls.

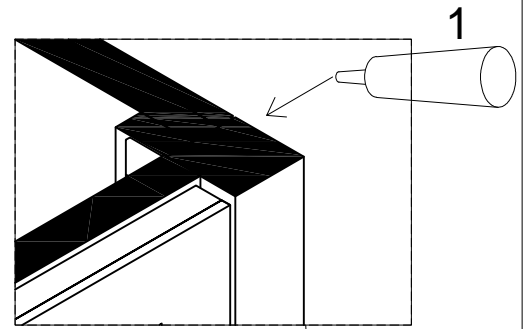

Pour installer le plan de travail (1) sur le meuble-lavabo (2), appliquez du mastic silicone sur le bord supérieur du meuble en bois. Avec l'aide d'un autre adulte, abaissez délicatement le plan de travail avec le lavabo assemblé sur le meuble. Assurez-vous que le plan de travail est bien aligné avec l'arrière du meuble en bois et les parois latérales gauche et droite du meuble.

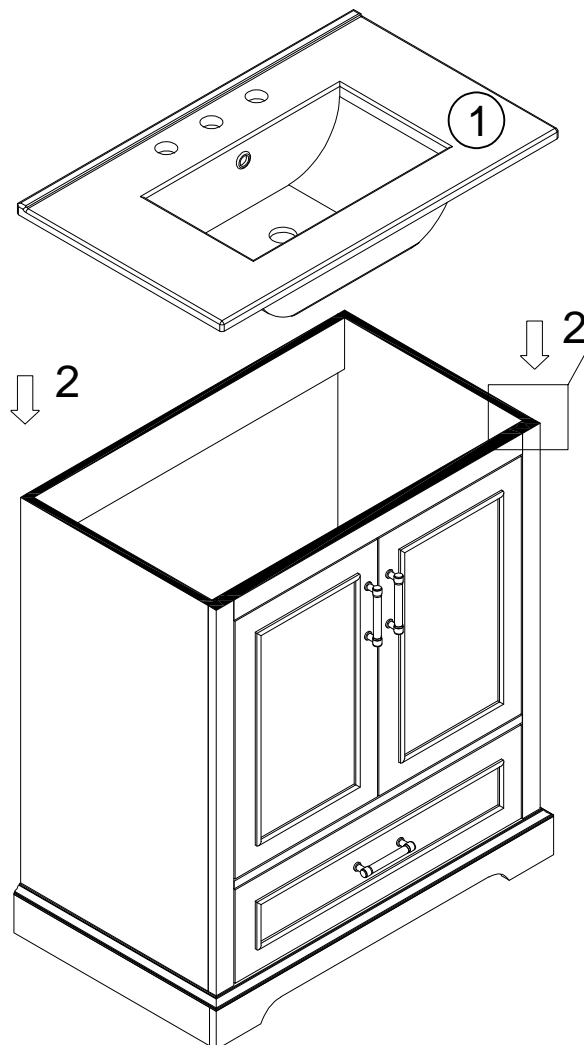

STEP 27
ÉTAPE 27

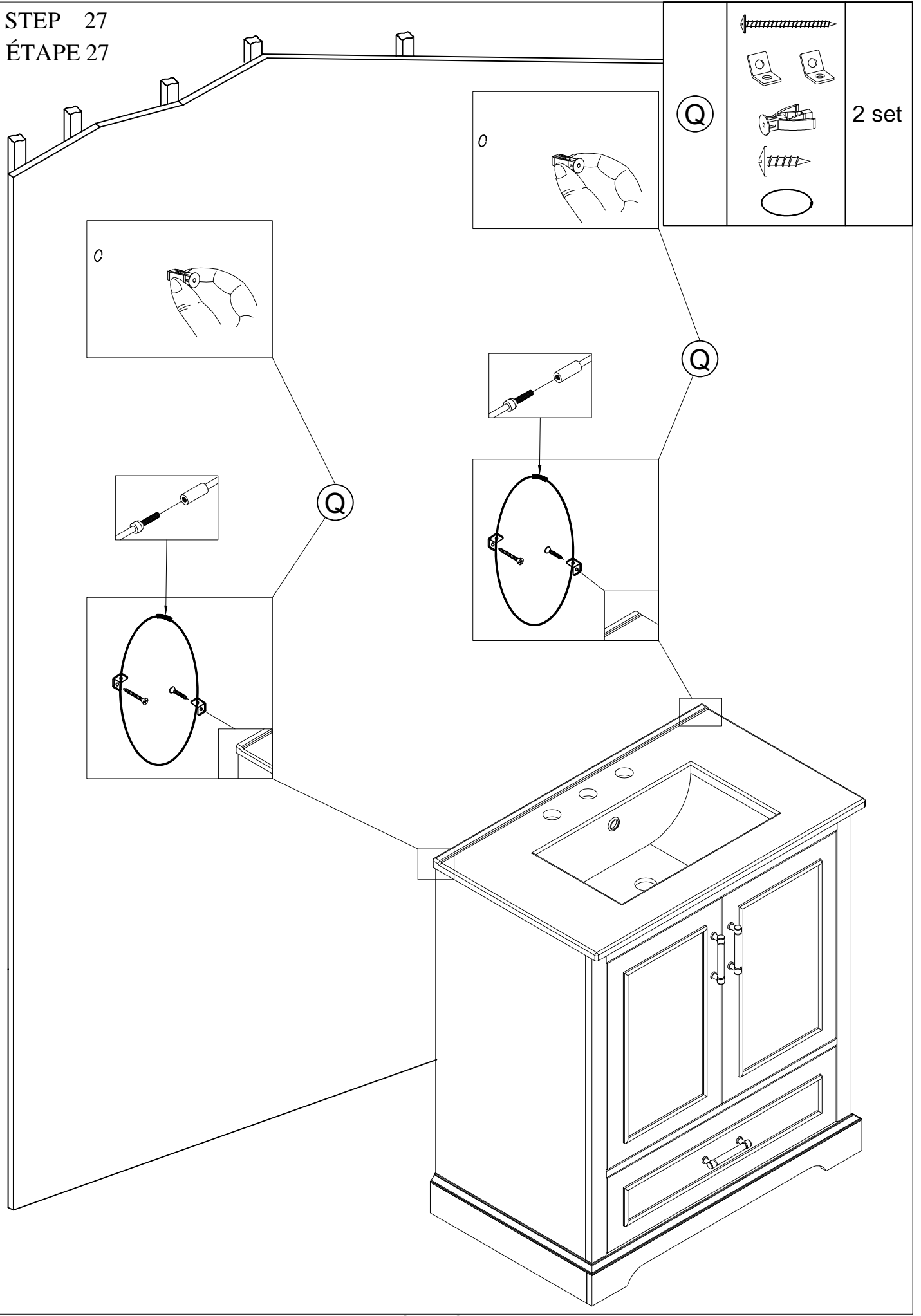

- | | | |
|---|--|-------|
| Q | | 2 set |
| | | |
| | | |
| | | |
| | | |

HINGE ADJUSTMENTS

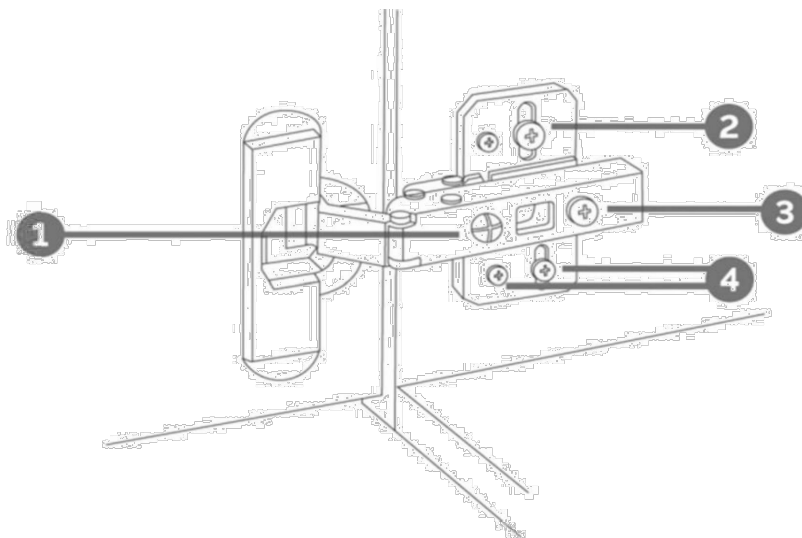

1 Sideways / Tilt adjustment

Turn the screw
clockwise to move the door further away from
the side of the cabinet
anticlockwise to move the door closer to the
side of the cabinet

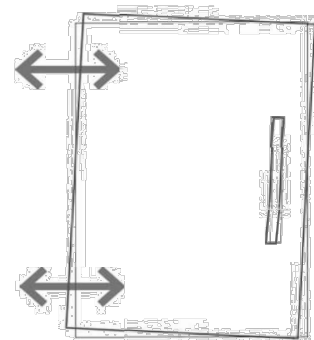

2 4 Height adjustment

While supporting the weight of the door, turn the
screws
clockwise to move the door up
anticlockwise to move the door down

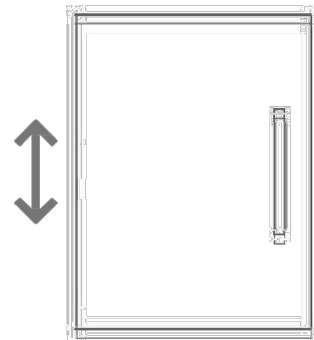

3 Forward and back adjustment

If the gap between the back of the door and the
cabinet is too small, and the door may not close
fully. Turn the screw
clockwise to decrease the gap between the
door and the cabinet
anticlockwise to increase the gap between the
door and the cabinet

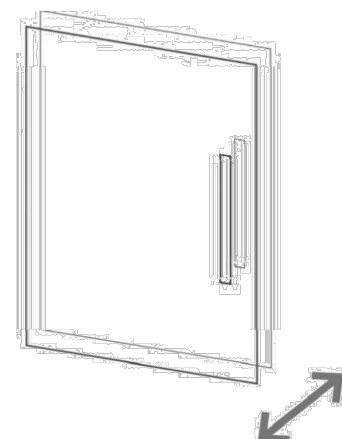

RÉGLAGES DES CHARNIÈRES

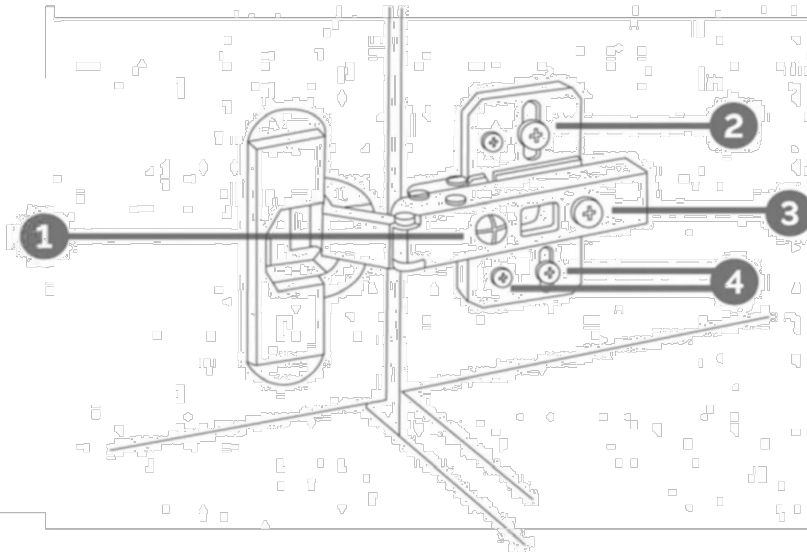

① De côté / Réglage de l'inclinaison

Tournez la vis dans le sens des aiguilles d'une montre pour éloigner la porte le côté du meuble
dans le sens inverse des aiguilles d'une montre pour rapprocher la porte du côté du meuble

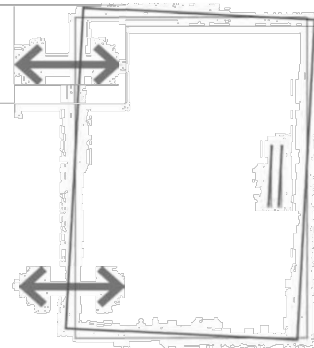

② ④ Réglage de la

Tout en supportant le poids de la porte, tournez les vis dans le sens des aiguilles d'une montre pour déplacer la porte vers le haut
dans le sens inverse des aiguilles d'une montre pour abaisser la porte

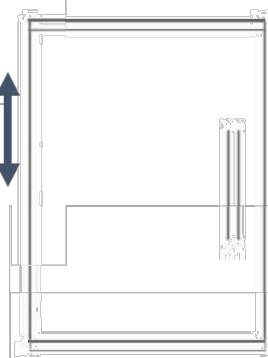

③ Réglage vers l'avant et vers l'arrière

Si l'espace entre l'arrière de la porte et le l'armoire est trop petite et la porte risque de ne pas se fermer complètement. Tournez la vis dans le sens des aiguilles d'une montre pour diminuer l'écart entre la porte et l'armoire
dans le sens inverse des aiguilles d'une montre pour augmenter l'écart entre la porte et l'armoire.

