

OFFICE CHAIR

PART LIST

KEY	QTY	DESCRIPTION
1	5	Caster
2	1	Base
3	1	Seat Post
4	1	Seat Post Cover
5	1	Seat
6	1	Mechanism
7	6	Mechanism Screw
8	1	Backrest Post
9	1	Backrest
10	1	Backrest Height Adjustment Knob
11	1	Backrest Post Bellow
12	1	Backrest Bolt + Washer
13	1	M5 Size Allen Wrench
14	1	M6 Size Allen Wrench

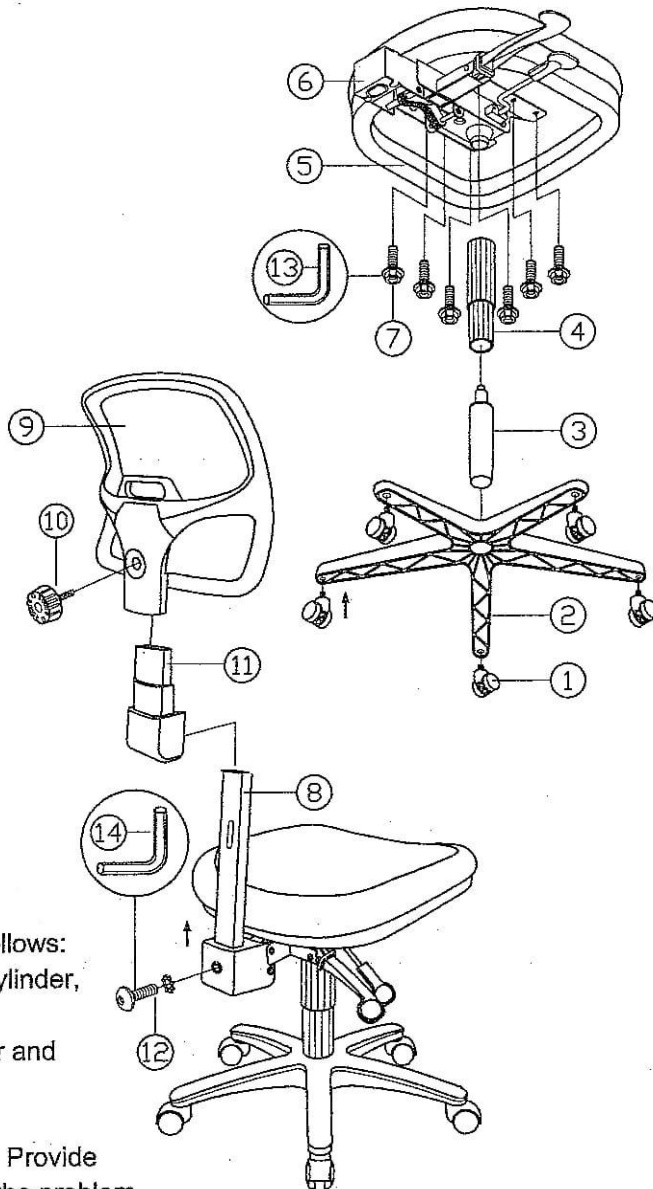

LIMITED WARRANTY

Our chairs are warranted* from the date of purchase against failure due to material and workmanship as follows:

- Lifetime on component parts including pneumatic cylinder, control mechanism, base and casters.
- 3 Years on upholstery fabric and foam against wear and deterioration.

To make a warranty claim, contact Parts Department. Provide model number, proof of purchase, and description of the problem and obtain return authorization. At it's option we will:

- Supply compatible components of current manufacture.
- Repair the customer's component. The customer must prepay freight on and components returned to the factory. Return freight on components still in warranty will be paid

**All warranties are limited to the original purchaser for normal commercial usage defined as a standard forty hour work week by persons weighing 250 lbs. or less. This warranty will not cover labor, freight or damage from misuse, abuse, negligence, alteration, accident, vandalism, rusting, acts of nature or any other event beyond the control of us. The warranty does not cover cosmetic damage that may result from normal use. Liability for incidental or consequential damages is excluded. The user assumes all risk of injury resulting from use of this product. When usage is more than 40 hours per week, a five year warranty on all parts applies. Fabric and foam is warranted for one year. This warranty gives you specific legal rights, and you may also have other rights which vary from state to state.*

Our quality standards are among the highest in the industry. Sometimes, no matter how hard we try, there are times when parts are damaged or missing. Our Parts Department will do everything possible to promptly remedy the problem. Contact us via e-mail , by Fax , or toll free parts number

ASSEMBLY INSTRUCTION

Remove all items from the carton . Verify all pieces before assembly.

STEP 1.

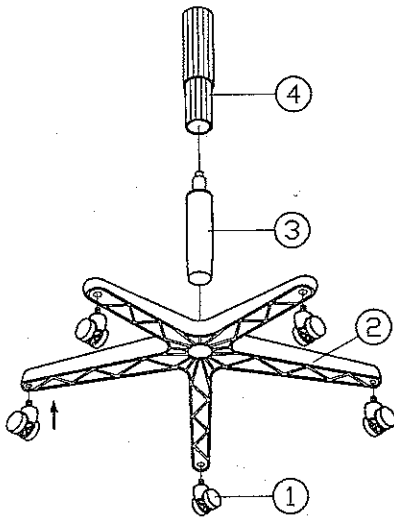

STEP 2.

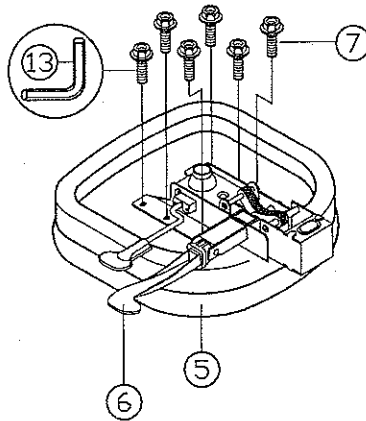

STEP 3.

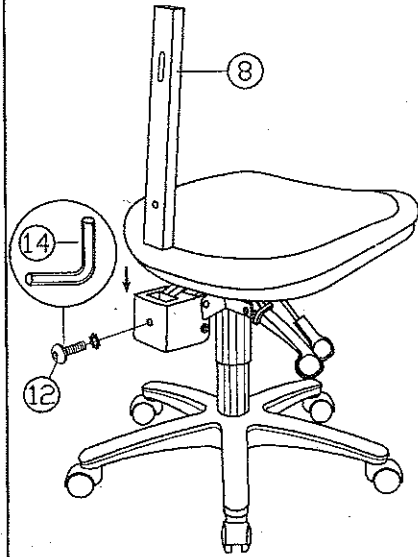

STEP 4.

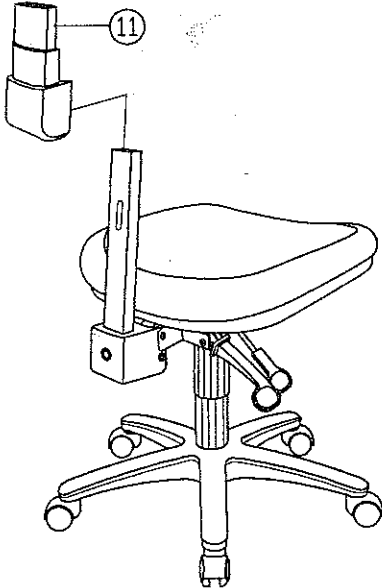

STEP 5.

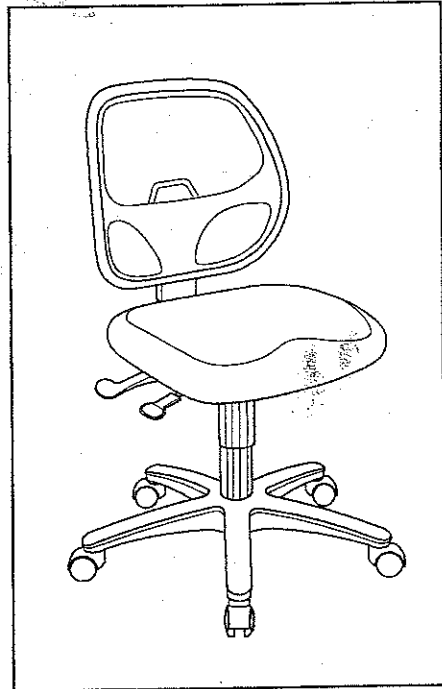
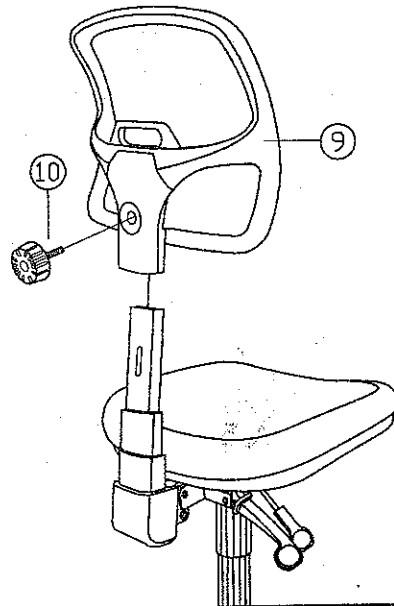

PREVENTIVE MAINTENANCE AND WARNING!

- USE THIS PRODUCT ONLY FOR SEATING ONE PERSON AT A TIME.
- DO NOT USE THIS CHAIR AS A STEP STOOL / LADDER.
- DO NOT SIT ON ANY PART OF THE CHAIR EXCEPT THE SEAT.
- DO NOT USE CHAIR ON UNEVEN FLOOR SURFACES.
- DO NOT USE CHAIR UNLESS ALL BOLTS, SCREWS AND KNOBS ARE TIGHTENED.
- EVERY SIX MONTHS, PLEASE MAKE SURE ALL BOLTS, SCREWS AND KNOBS ARE FULLY TIGHTENED TO ENSURE STABILITY.
- IF ANY PARTS ARE MISSING, BROKEN, DAMAGED OR WORN, STOP USE OF THE PRODUCT UNTIL REPAIRS ARE MADE USING FACTORY AUTHORIZED PARTS.
- DISPOSE OF PACKAGING PROPERLY. PLASTIC BAG IS NOT A TOY. DO NOT USE PLASTIC BAG AS HEAD COVERING - IT MAY CAUSE SUFFOCATION.
- FAILURE TO FOLLOW THESE WARNINGS COULD RESULT IN SERIOUS INJURY.