

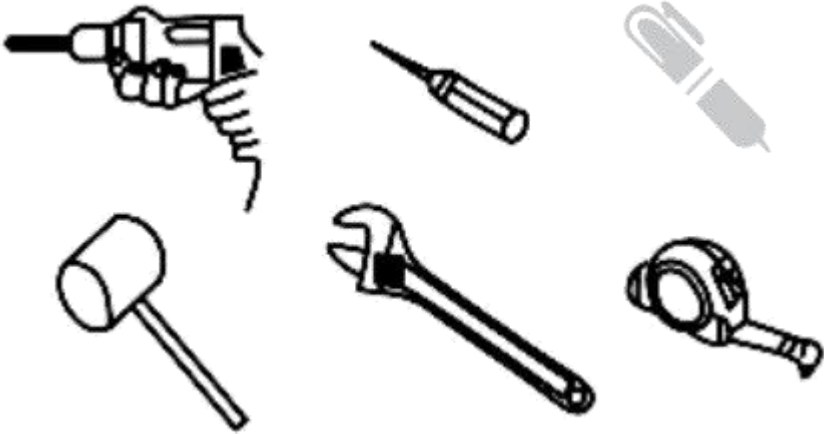

# SHOWER PANEL

# INSTALLATION

Required tools: electric drill, screwdriver, marker, hammer, wrench, tape measure.



- 1, The shower screen installation height can be flexible and applicable.
- 2, Hot and cold water within 15CM can be installed within the distance.
- 3, Combined with the toilet wall to avoid the height of hot and cold water outlet and the height of their own need to install the shower screen at a suitable height position can be.

## Step 1

First measure the distance of the upper and lower slots of the shower panel , and then use the marker to mark the location.

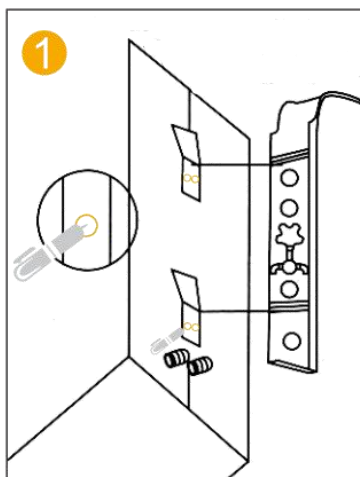

## Step 2

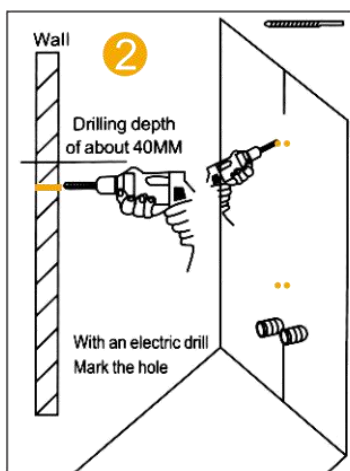

**Step 3 & Step 4**

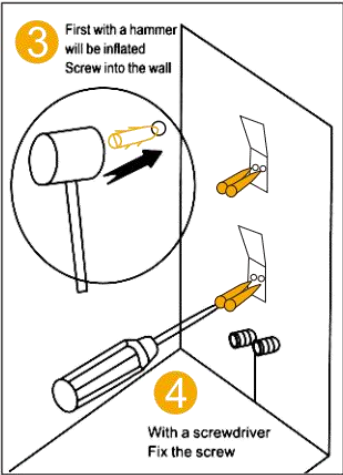

**Step 5**

Install the shower panel in the hole of the right side, then the hose can be connected.

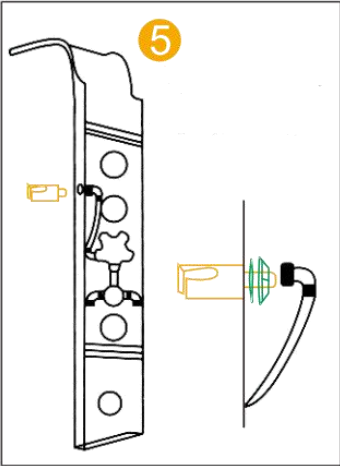

## Step 6

First turn the elbow and the wall pipe connected respectively. And then the hot and cold water pipes and elbows can be connected.

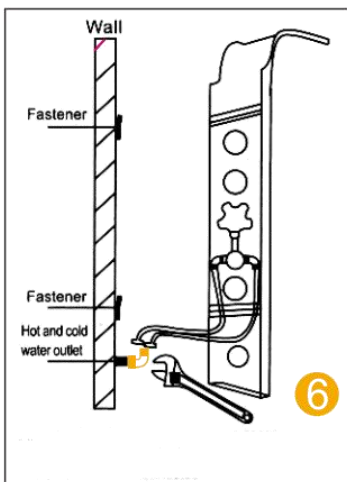

## Step 7

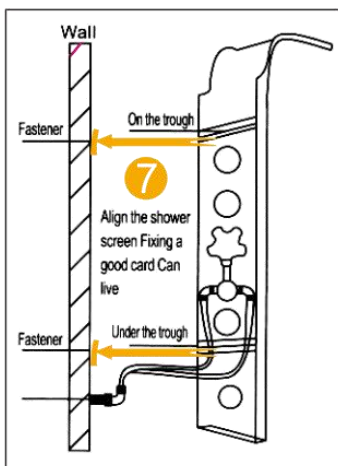

**Step 8**

Connect the shower hose to the shower panel.

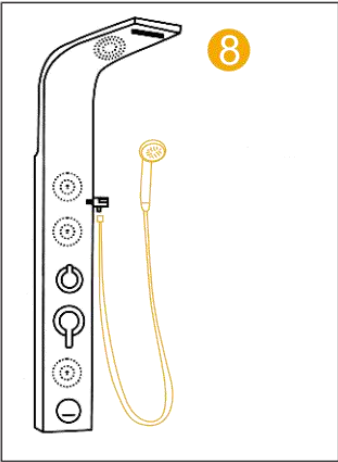

**Step 9**

Installation is finished.

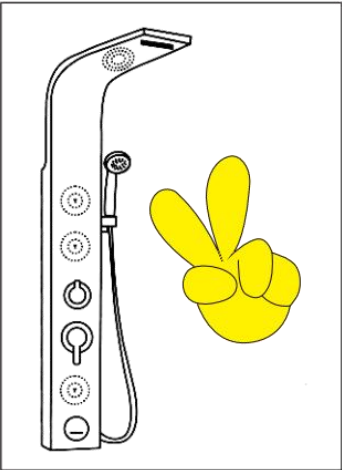

# INSTALLATION COMPLETE SIDE REFERENCE DIMENSION DRAWING

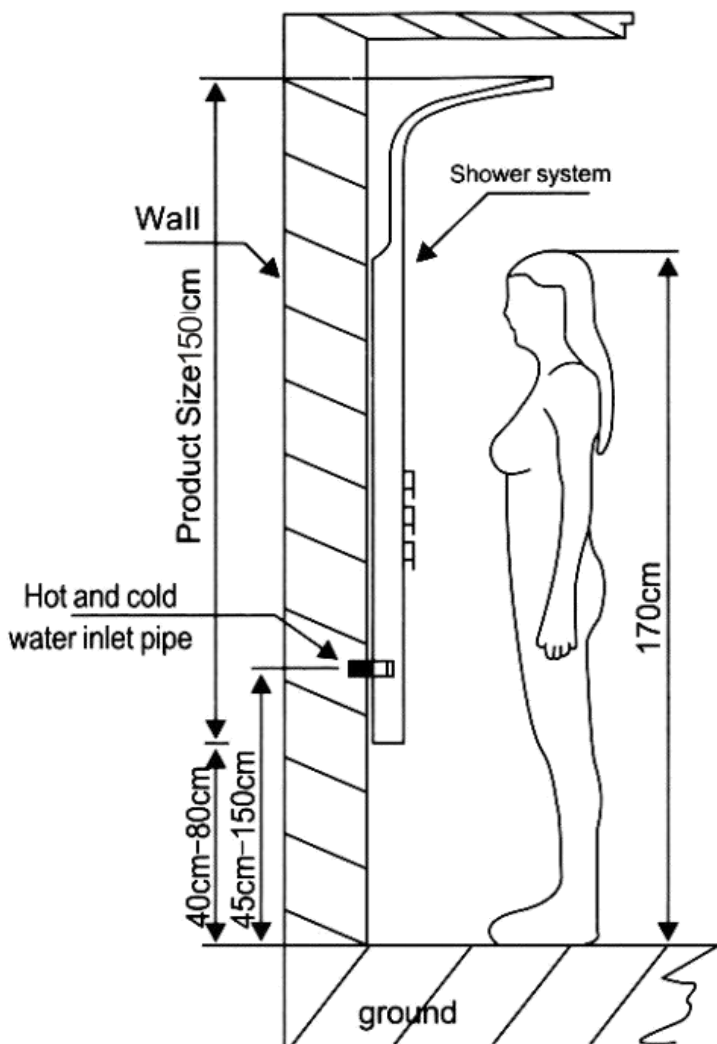

# RESERVED WATER LAYOUT

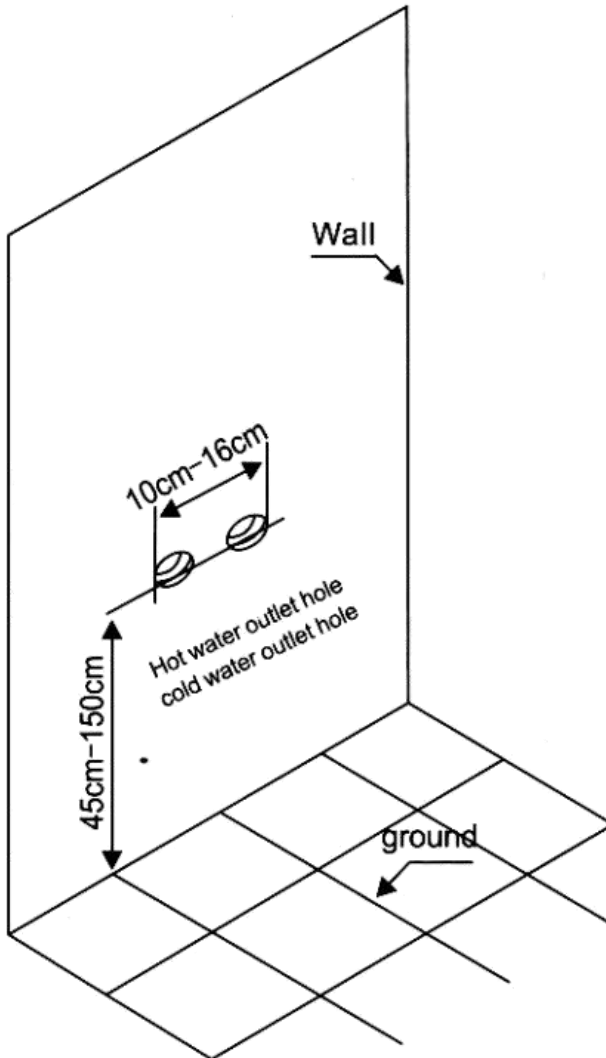

## INSTALLATION NOTES

1. According to the height of the family to set the shower system installation height. Measure the bar distance on the back of the shower system, mark on the wall, fix hanging iron in the corresponding positions (one above and one below).
2. Connect the hot and cold water hose (be sure to clean the dirt in the wall scale, so as not to block, affect the water effect).
3. When the shower system is hung on the wall, the upper and lower cards are clamped in two hanging paste (Note: shower after the system wall, the main body close to the wall is not shaking, no need to use another glass glue or other tools).

## MAINTENANCE METHODS

1. Clean the product regularly in order to keep its appearance bright and clean.
2. Clean the surface with water or a mild detergent and wipe it with a soft towel.
3. Clean the hidden positions of the product, timely cleaning can make product lasting.

# WARRANTY CARD

## Special statement

- 1, The company reserves the right to change the product technology, without notice.
- 2, Product appearance, color, if different, are subject to the subject.

## User Info

User name		Telephone		Zip code	
Mailing address	State/Province/State			City (country)	
Product Number			Numbering		
Place of purchase			Date of purchase		
Maintenance outlets			Invoice number		

- 1, The quality of the product itself can be warranty. Note: The panel is not covered by the warranty, please unbox the first time to check.
- 2, Under any of the following circumstances free warranty service can not be enjoyed, but paid maintenance is provided:
  - (1) Damaged by use, maintenance and improper custody of the consumers;
  - (2) The damage caused by the self-dismantling of the consumers;
  - (3) The warranty certificate and repair product model does not meet or alter;
  - (4) Damage caused by force majeure.
- 3, The warranty period starts from the invoice date of the product.
- 4, Please reprint the warranty certificate and invoice.
- 5, Beyond the warranty period or do not belong to the free maintenance of the products, the company's maintenance center is still dedicated to your service.
- 6, If we need to provide services, please contact the local dealer or call the company service hotline.

# MAINTENANCE RECORDS

Date	Maintenance content	Replace parts		Maintenance staff	User signature
		Name	Quantity		