

Assembly Instructions







COUNTER TABLE
COUNTER CHAIR (SET INCLUDES 4 CHAIRS)

Thank you for purchasing this quality product. Be sure to check all packing materials carefully for small parts, which may have come loose inside the carton during shipment. Identify and count all items and compare with the PARTS LIST and/or HARDWARE LIST shown below.

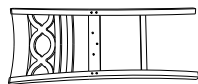
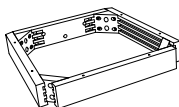



Caution: Please read the instructions thoroughly before assembly.

1. We recommend that you assemble this product with the assistance of another person; this will make the assembly easier, and will help eliminate damage to the product or injury to persons during assembly.
2. Please do not over tighten screws or bolts until the assembly is completed.
3. Please put all parts on a non-abrasive floor before assembly, and follow the assembly steps to assemble your newly purchased product correctly and efficiently.

PARTS LIST

NO.	COMPONENT	SKETCH	QTY.
A	CHAIR BACK		4 PCS
B	SEAT FRAME		4 PCS
C	CUSHION SEAT		4 PCS
D	FRONT LEG (LEFT)		4 PCS
D	FRONT LEG (RIGHT)		4 PCS
E	SIDE STRETCHER (LEFT)		4 PCS
E	SIDE STRETCHER (RIGHT)		4 PCS
F	FRONT STRETCHER		4 PCS

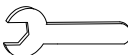
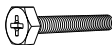
HARDWARE LIST

NO.	COMPONENT	SKETCH	QTY.
1	FLAT WASHER 5/16" DIA.		44 PCS
2	SPRING WASHER 5/16" DIA.		44 PCS
3	NUT 5/16" DIA.		16 PCS
4	ALLEN WRENCH 5/16" DIA.		1 PC
5	SHORT BOLT 1/4" x 1 3/4"		12 PCS
6	LONG BOLT 1/4" x 3"		16 PCS
7	WOOD SCREW 5/32" x 1 1/2"		48 PCS

Assembly Instructions

COUNTER TABLE
COUNTER CHAIR (SET INCLUDES 4 CHAIRS)

To assemble the chairs, please follow the following steps and repeat for each chair:

STEP 1

Lay the chair back on soft clean surface and install the seat frame.

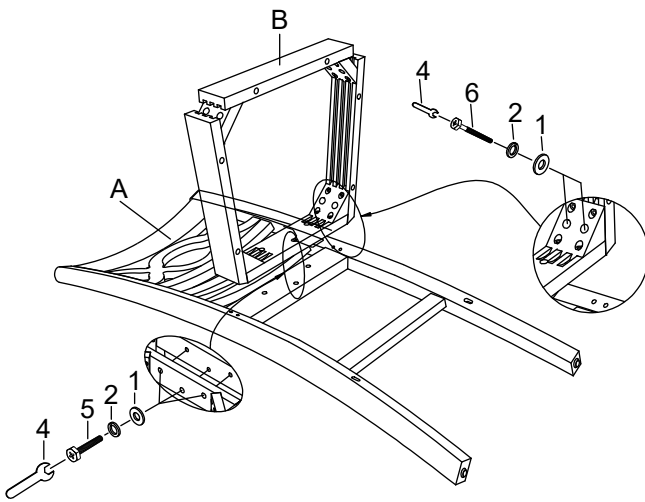

STEP 2

Insert side stretchers with wood screws.

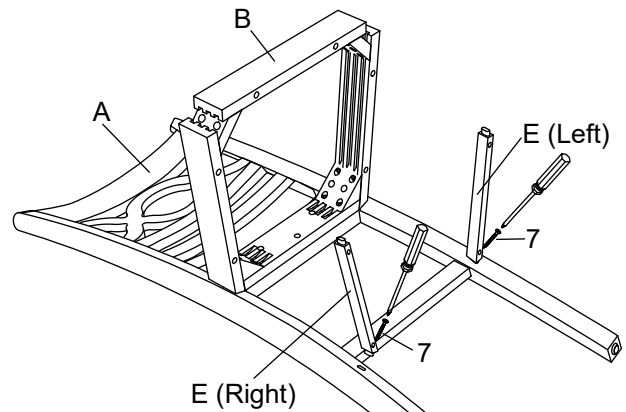

STEP 3

Install front stretcher into the holes of the front legs then attached to the seat frame.

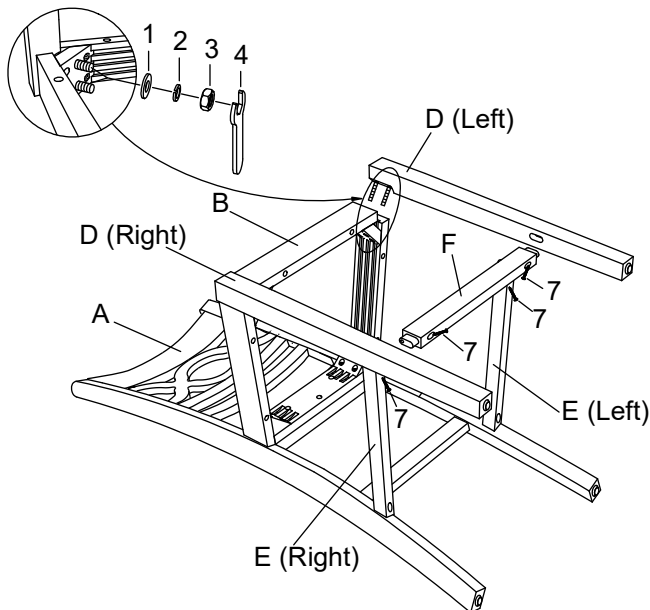

STEP 4

Place the assembled seat frame on the cushion seat and attach with wood screws.

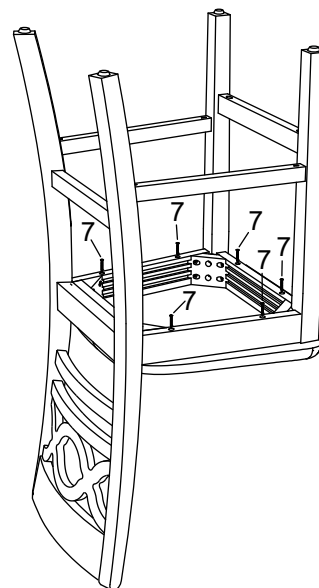



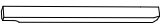
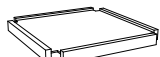

Assembly Instructions

COUNTER TABLE
COUNTER CHAIR (SET INCLUDES 4 CHAIRS)

PARTS LIST

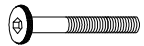
NO.	COMPONENT	SKETCH	QTY.
A	TABLE TOP		1 PC
B	TABLE LEG		4 PCS
C	TABLE SHELF		2 PCS

HARDWARE LIST

NO.	COMPONENT	SKETCH	QTY.
1	BOLT 5/16" x 2 1/2"		12 PCS
2	SPRING WASHER 5/16" DIA.		12 PCS
3	FLAT WASHER 5/16" DIA.		12 PCS
4	ALLEN KEY 1/4" DIA.		1 PC

To assemble the table, please follow the following steps but do not tighten all bolts:

STEP 1

Attached the table shelves to two of the table legs.

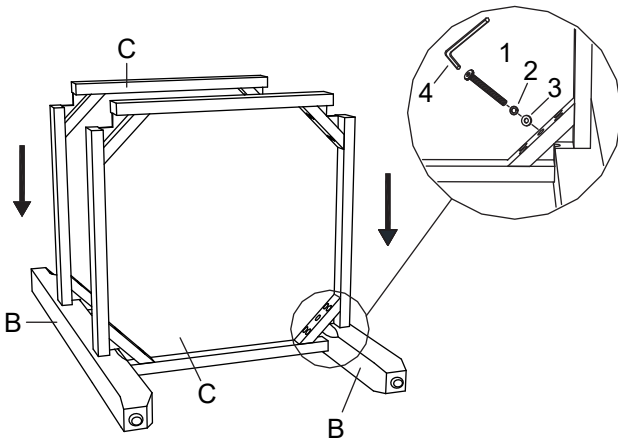

STEP 2

Attached the two other legs.

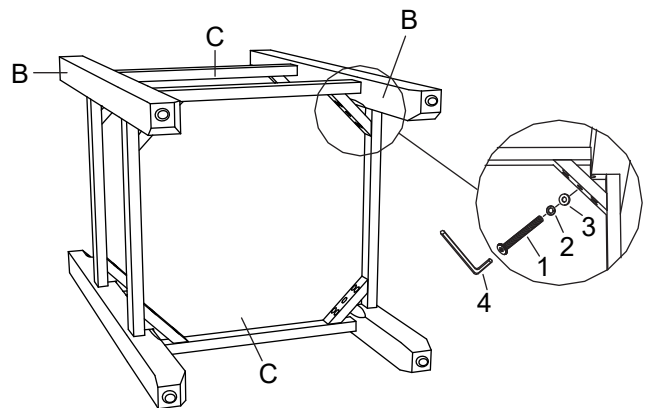

STEP 3

Turn the assembly upright and place the table top on the assembled unit.

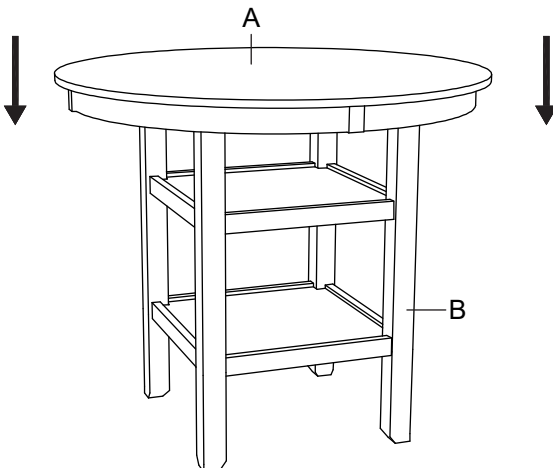

STEP 4

Secure the table top with bolts. Make sure the table is level, then tighten all bolts.

