

---

# ASSEMBLY INSTRUCTIONS

## HALL TREE WITH STORAGE BENCH

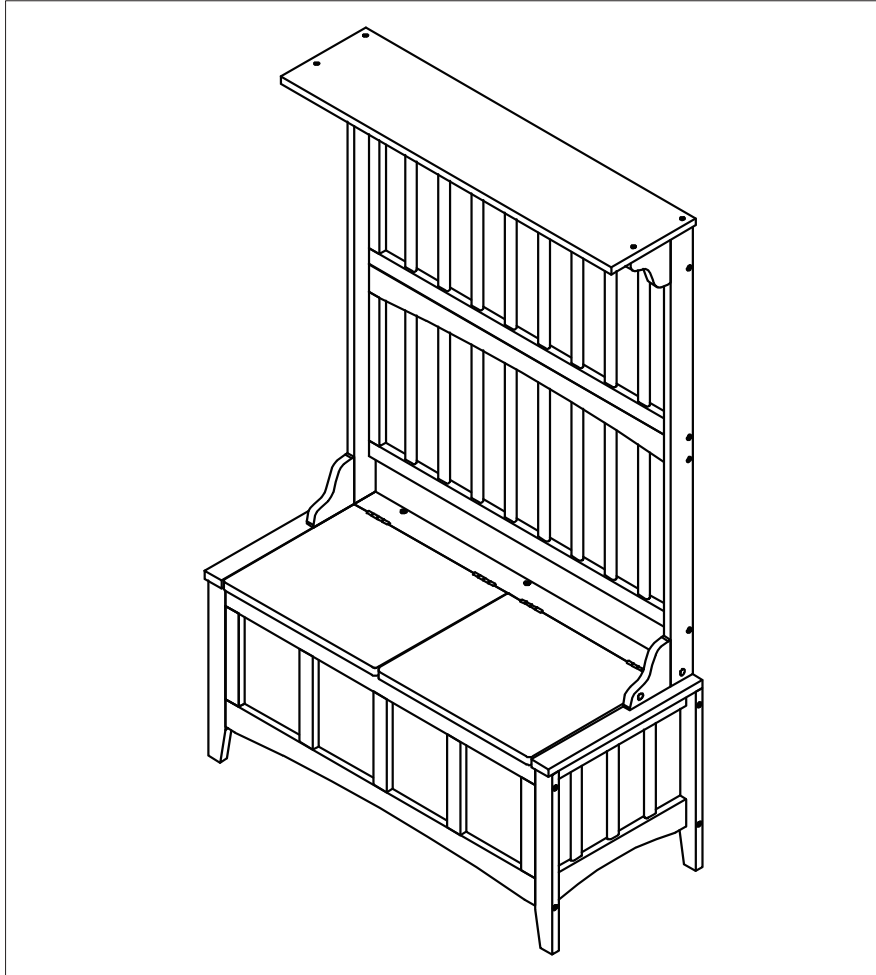

---

# PARTS IDENTIFICATION

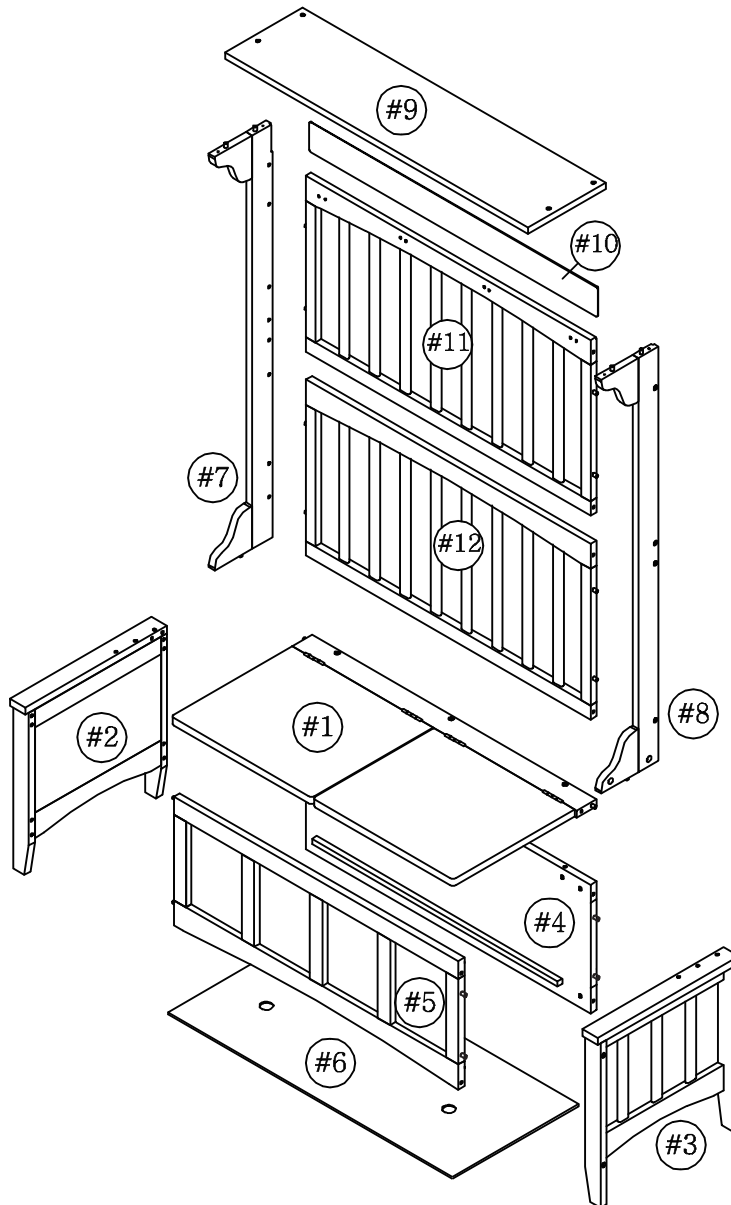

For ease of identification all parts are labeled to correspond to the Step number in which the part is used.







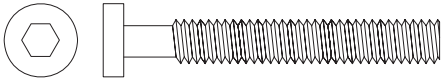
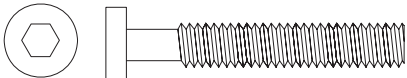

---

## PARTS IDENTIFICATION

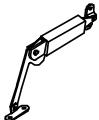
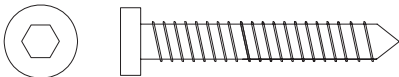
ITEM	DESCRIPTION	QTY
#1	SEAT	01
#2	LEFT SIDE FRAME	01
#3	RIGHT SIDE FRAME	01
#4	BACK FRAME	01
#5	FRONT FRAME	01
#6	BOTTOM FRAME	01
#7	LEFT SIDE PIECE	01
#8	RIGHT SIDE PIECE	01
#9	TOP PANEL	01
#10	CAP RAIL	01
#11	UPPER BACK PANEL	01
#12	LOWER BACK PANEL	01











## HARDWARE IDENTIFICATION

Please line up the hardware with the correct full size image to make sure you are installing the hardware correctly.

ITEM	PICTURE	DESCRIPTION	QTY
A	 $(\text{Ø}1'' \times 3'')$ Full size	BOLTS	08
B	 $(\text{Ø}1'' \times 1\frac{1}{2}'')$ Full size	BOLTS	03
C	 Not to Scale	LEFT SAFETY HINGE	01
D	 Not to Scale	RIGHT SAFETY HINGE	01
E	 5x35mm Full size	SCREWS	12
F	 Not to Scale	BARREL NUT	11
G	 Not to Scale	WOOD PLUGS	16
H	 Not to Scale	CAM LOCK	04
I	 Not to Scale	CAM BOLTS	04
J	 Not to Scale	PLASTIC CAP	04

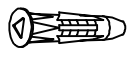
## HARDWARE IDENTIFICATION

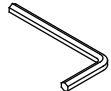
Please line up the hardware with the correct full size image to make sure you are installing the hardware correctly.

ITEM	PICTURE	DESCRIPTION	QTY
K	 Not to Scale	HOOK	04
L	 Not to Scale	METAL BRACKET	02
M	 $(\text{Ø}\frac{1}{8} \times \frac{5}{8})$ Full size	SCREWS	16
N	 $(\text{Ø}8 \times 30\text{mm})$ Full size	WOOD DOWEL	26
O	 $(\text{Ø}\frac{1}{8} \times \frac{1}{2})$ Full size	SCREWS	08
P	 $(\text{Ø}\frac{5}{32} \times 1\frac{3}{16})$ Full size	WALL SCREW	02
Q	 Not to Scale	WALL PLUG	02
R	 Not to Scale	STRAP	02
S	 Not to Scale	ALLEN KEY	01
U	 $(\text{Ø}\frac{1}{8} \times \frac{5}{8})$ Full size	SCREWS	08

## STEP 1.

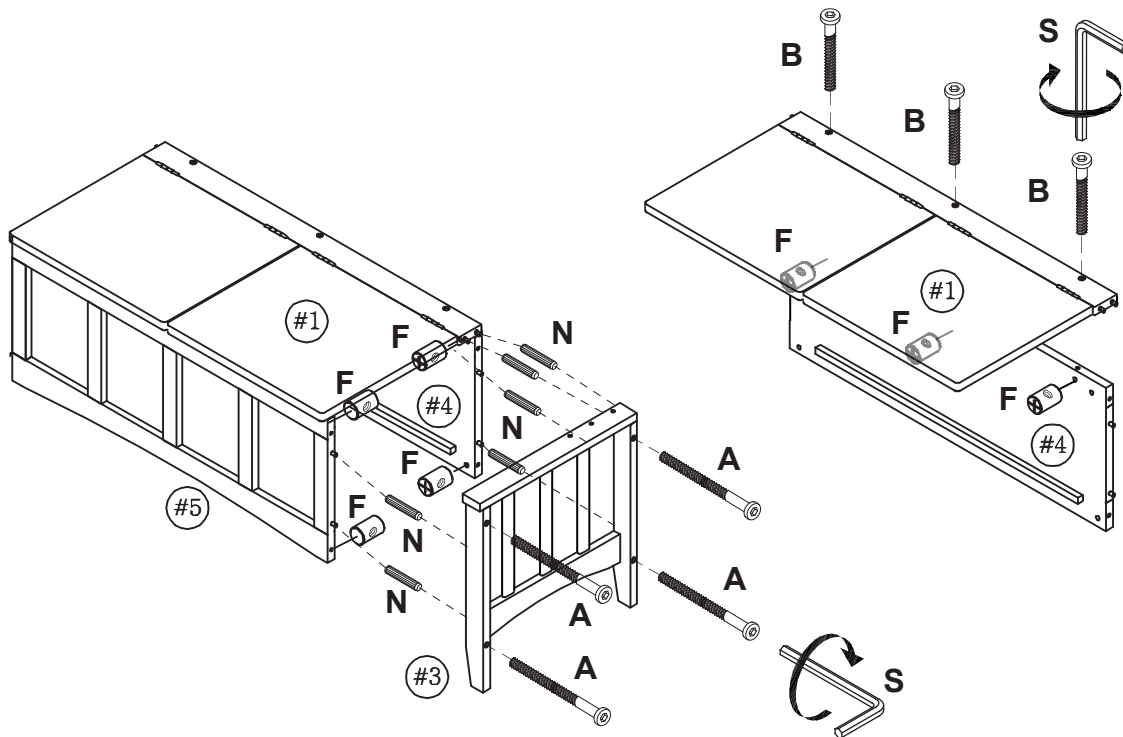

## STEP 2.

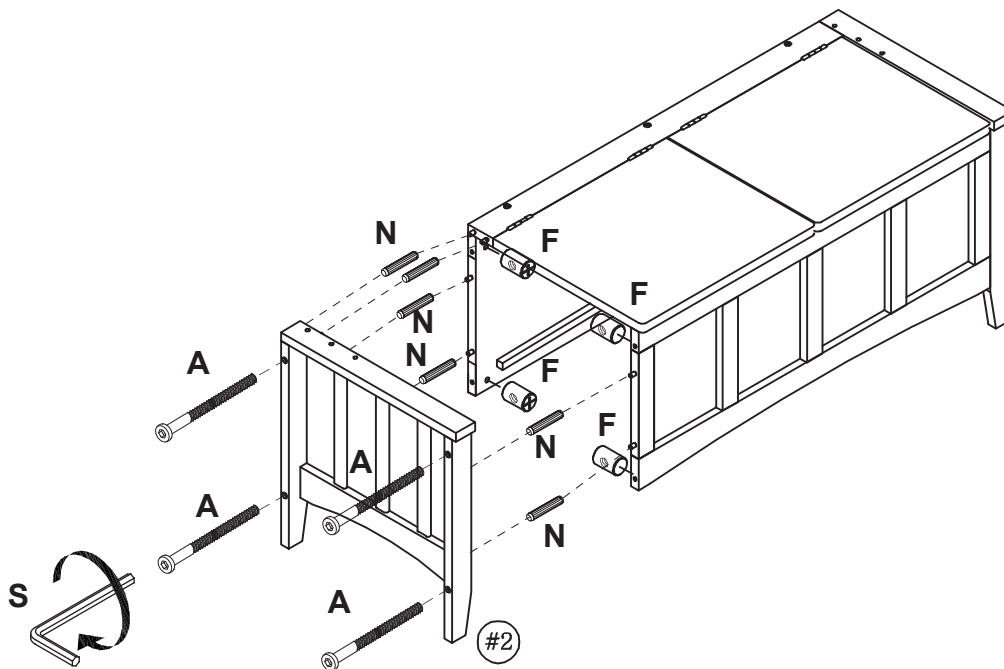

## IMPORTANT:

1. DO NOT TIGHTEN BOLTS COMPLETELY UNTIL ALL BOLTS ARE COMPLETELY LINED UP AND INSERTED INTO HOLES / NUTS.
2. DO NOT OVER TIGHTEN SCREWS AND BOLTS TO AVOID STRIPPING.

STEP 3.

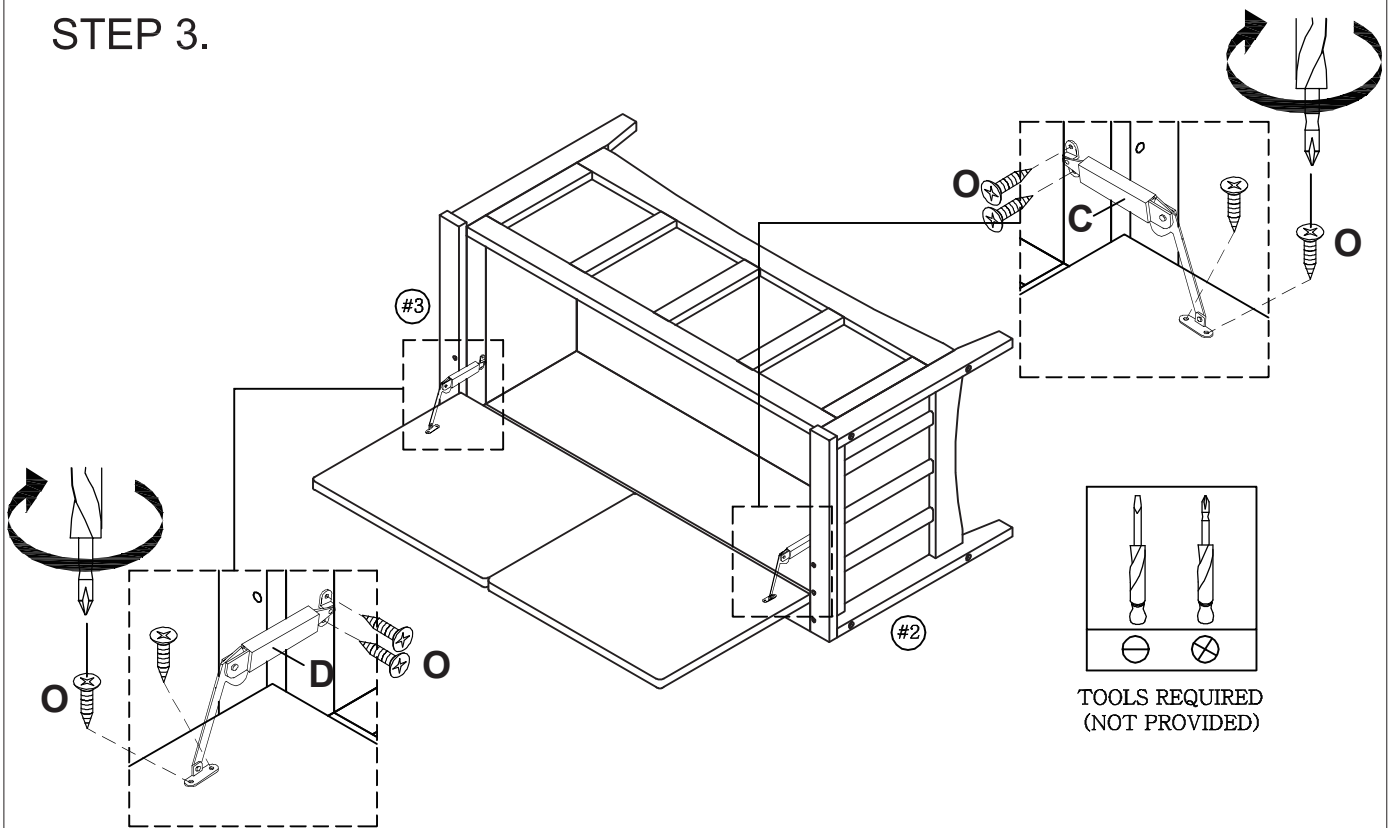

STEP 4.

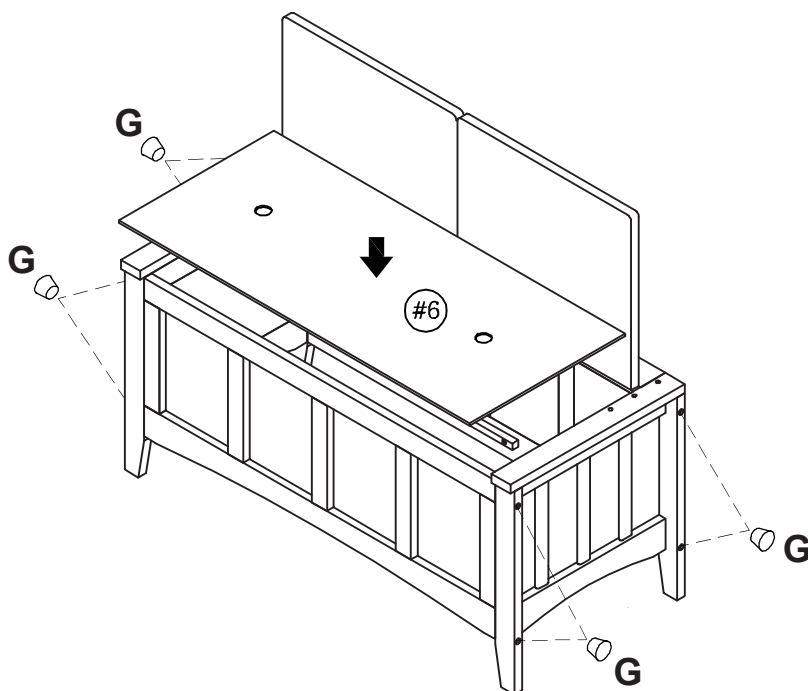

**STEP 5.**

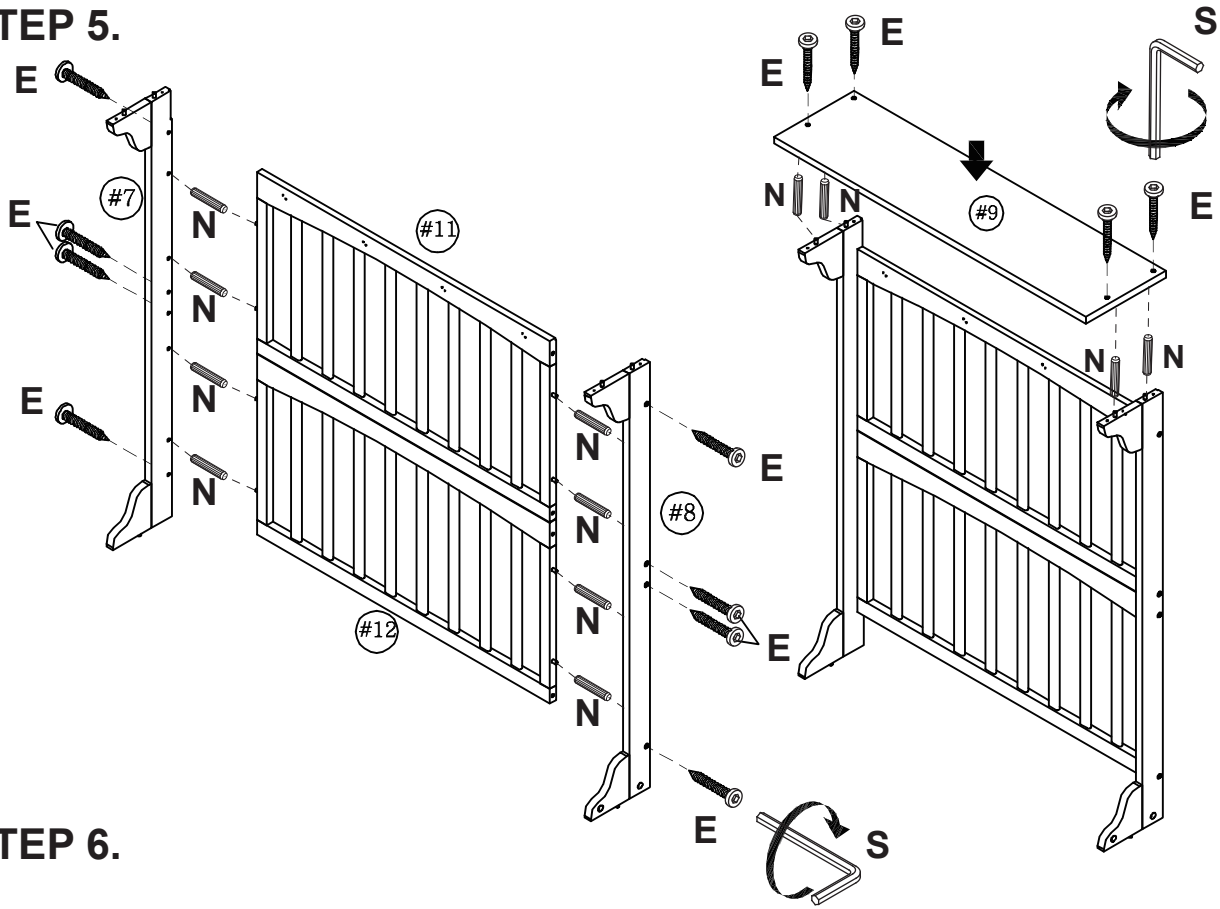

**STEP 6.**

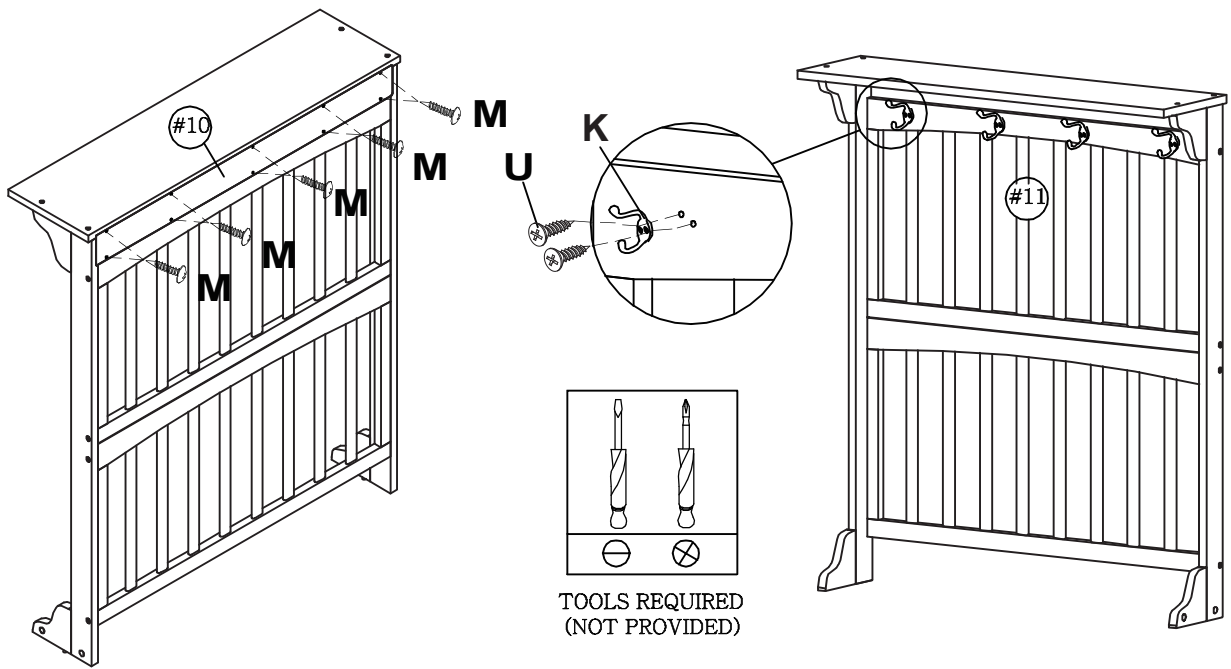



**STEP 7.**

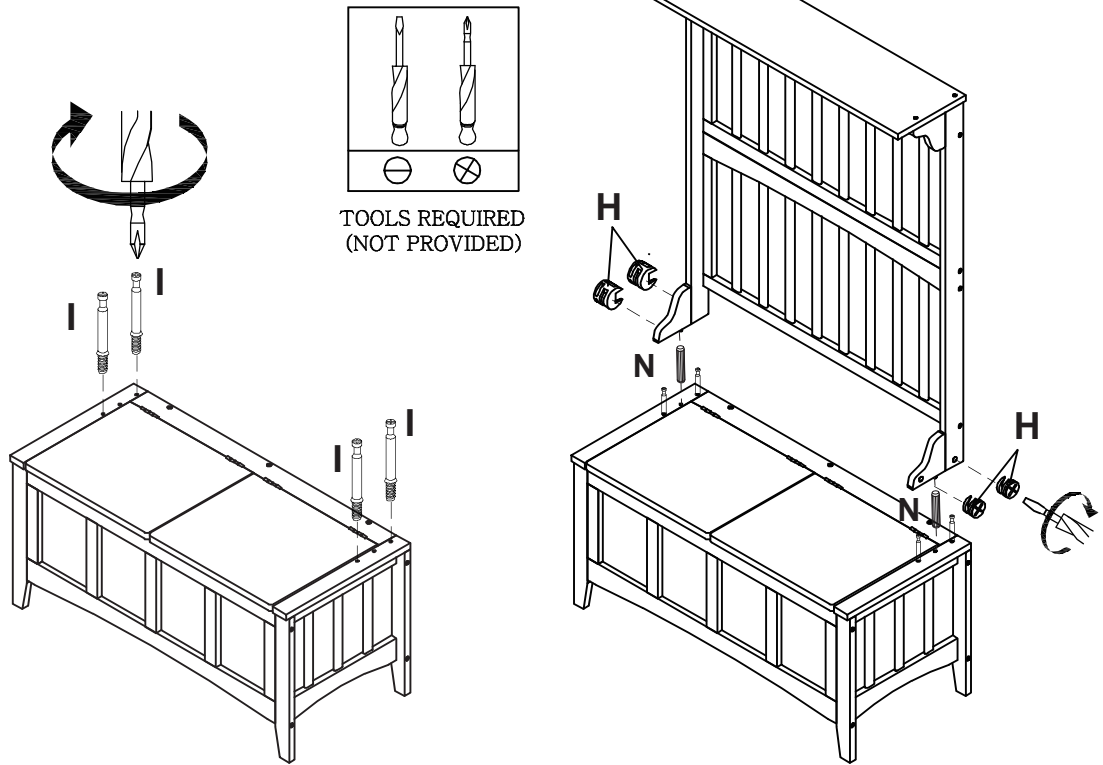

**STEP 8.**

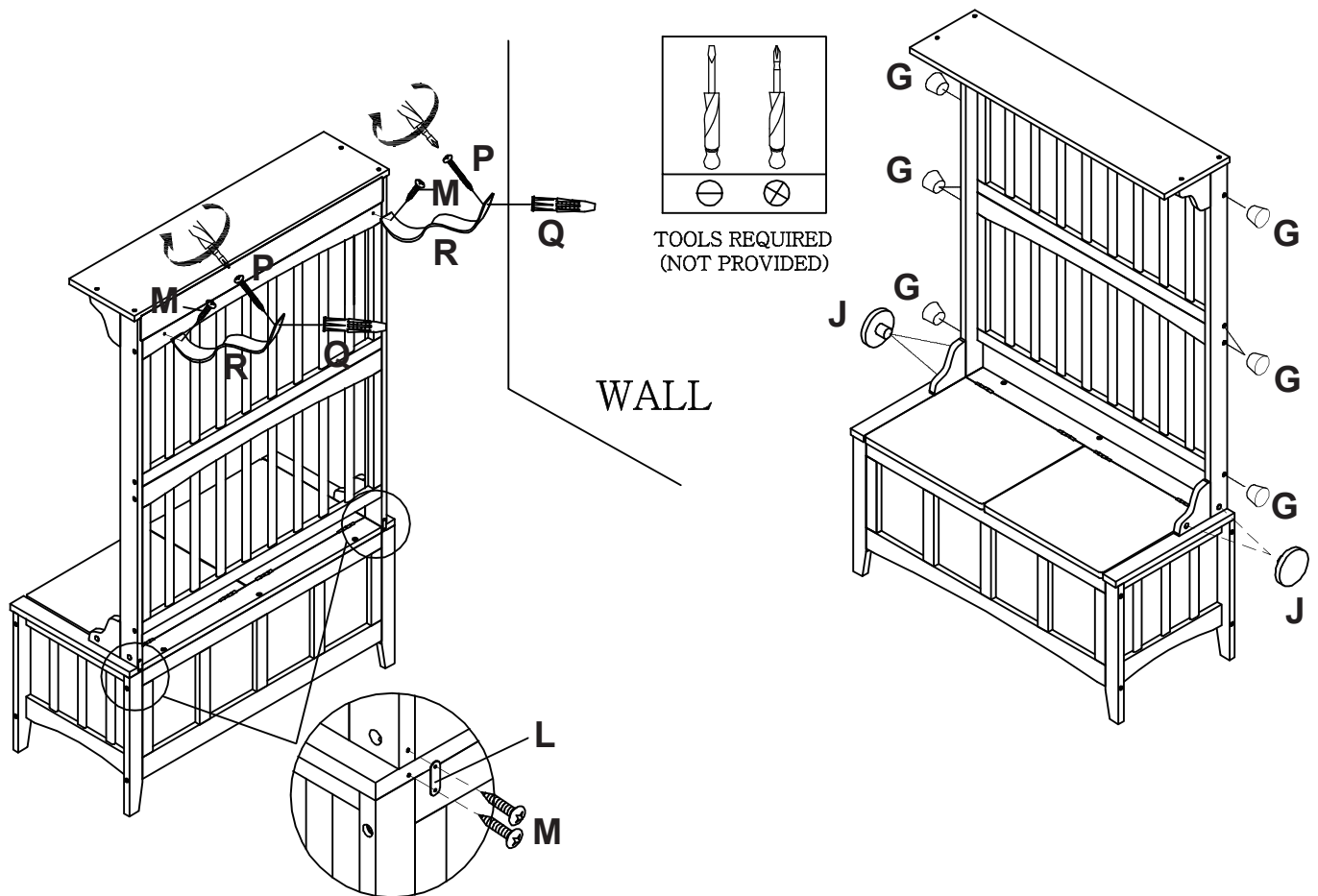

## COMPLETED ASSEMBLY

