

# Bench

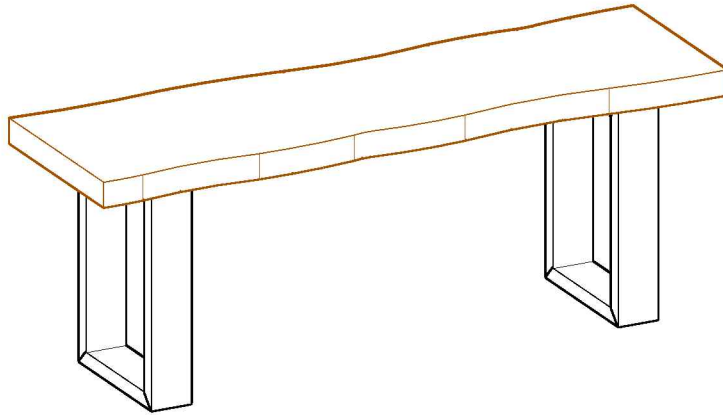



Thank you for purchasing our Bench. It will be helpful to have a second person available during the assembly of this product.

---

## Assembly Instructions

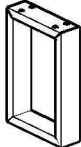
Lay out all parts on a "non-abrasive" surface to avoid scratching furniture.

NO.	DRAWING	DESCRIPTION	QTY.
A		TOP	1
B		LEG	2

NO.	DRAWING	DESCRIPTION	QTY.
C		M6X35MM BOLT	8
D		ALLEN KEY	1

### Step 1

Read through these instructions thoroughly before beginning assembly. We have found this to be of great value when first assembling this product.

### Step 2

Remove all parts and hardware from packing material. Wooden pieces should be placed on a non abrasive surface (like the carton or carpet) to prevent damage to the finish.

### Step 3

Lay Top (A) upside down and attach 2 Leg (B) using 8 6M x 35MM Bolts (C)  
**TIGHTEN ALL BOLTS FIRMLY AT THIS TIME.**

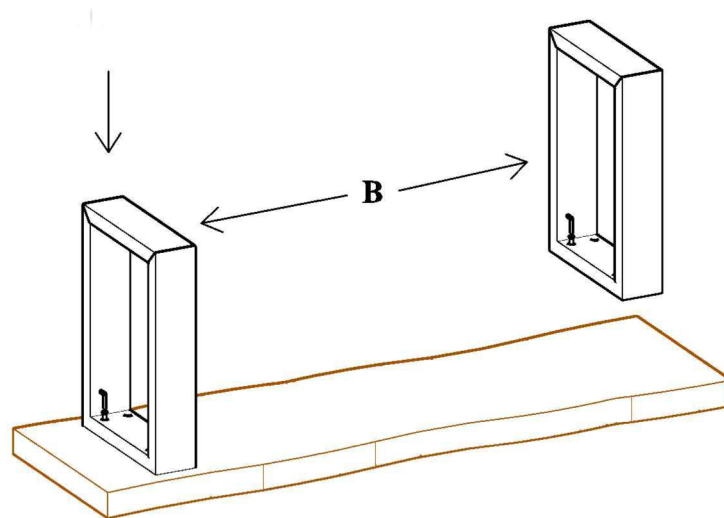

### Step 4

Set Bench Upright

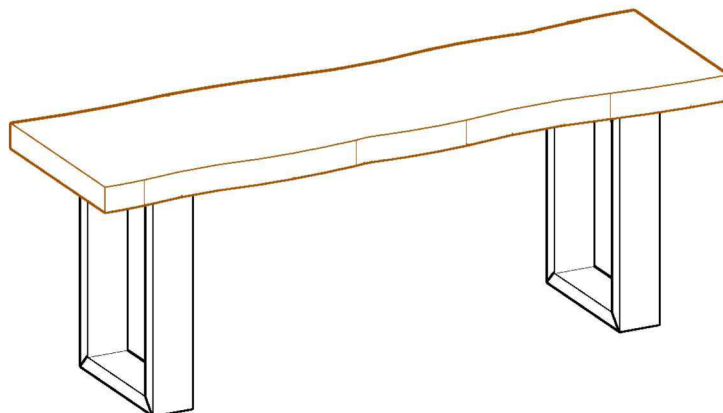

---

### CARE

Clean with mild soap and wipe dry.