

# ASSEMBLY INSTRUCTIONS

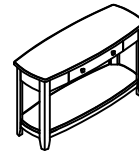

066-925

## TOOLS REQUIRED:

Allen Wrench (Provided, Part D)

## BEFORE YOU START:

1. Check the hardwares against the hardware list to make sure all items are present.
2. Assemble your furniture on a soft, flat surface to avoid scratching the finish.
3. **CAUTION:** Do not over tighten screws, nuts or bolts during assembly.
4. Your furniture may require occasional tightening.

## INSTRUCTIONS:

1. Turn the table on to a clean soft surface.
2. Attach three legs to top using Bolt (C), Lock Washer (B) and Flat Washer (A) and tighten with the Allen Wrench (D). As Shown in Figure 1.
3. Attach shelf to three legs using Bolt (C), Lock Washer (B) and Flat Washer (A) and tighten with the Allen Wrench (D). As Shown in Figure 2.  
(Noted: Make sure the counter weight is always on the back side of the shelf after assembled the shelf. So following the direction of the label on the shelf and top when assemble the shelf.)
4. Repeat the step 2 & 3 for the fourth leg. As show in Figure 3.
5. Tighten all bolts before setting table back upright.

Figure 1

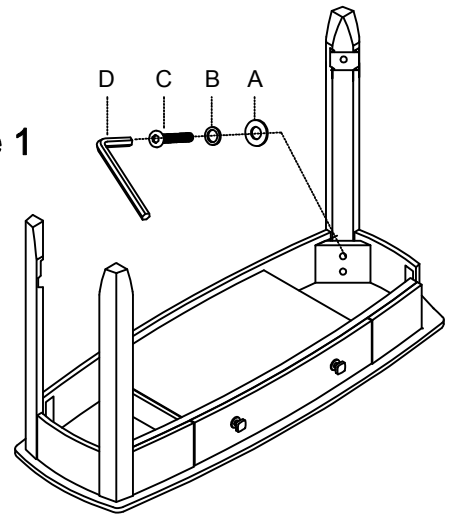

Figure 2

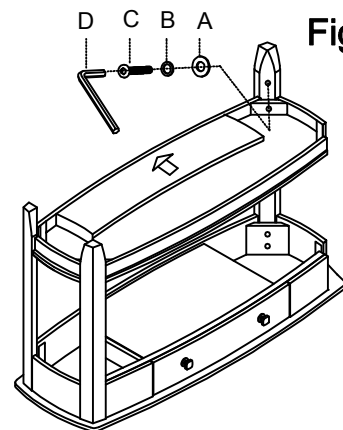
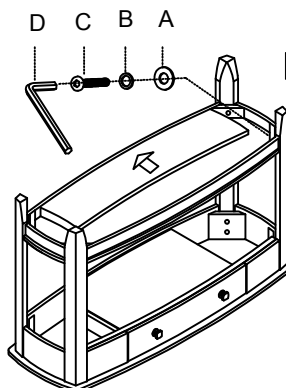





Figure 3



HARDWARE LIST			
A		Flat Washer (Ø5/16" )	12pcs
B		Lock Washer (Ø5/16")	12pcs
C		Bolt (Ø5/16"x1-3/4")	12pcs
D		Allen Wrench	1pcs