

Assembly Instructions

Glider



PARTS (included)

(A) Glider Seat (1)

(B) Glider Back (1)

(C) Left Glider Leg (1)

(D) Right Glider Leg (1)

(E) Glider Braces (2)

(F) Left Glider Foot (1)

(G) Right Glider Foot (1)

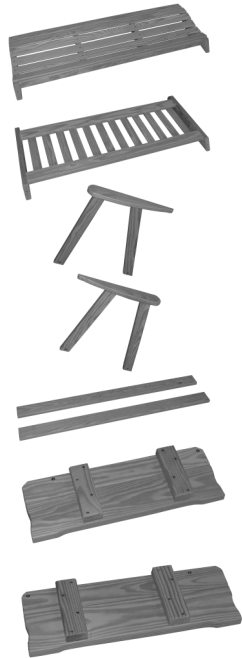

HARDWARE (included)

1/4" x 4 3/4" Bolts (2)

1/4" x 2 3/4" Bolts (4)

1/4" x 2" Bolts (2)

1/4" x 1 3/4" Bolts (8)

Glider Brackets (4)

2 1/2" Wood Screws (8)

Allen Wrench (1)

Square Drive Bit (1)

(a)

(b)

(c)

(d)

(e)

(f)

(g)

(h)



TOOLS NEEDED

Power Screwgun and/or Drill

STEP 1

Attach the glider legs to the seat using 2 3/4" bolts as shown in photos 1, 2, & 3. **Do not fully tighten bolts until step 2 is completed.**

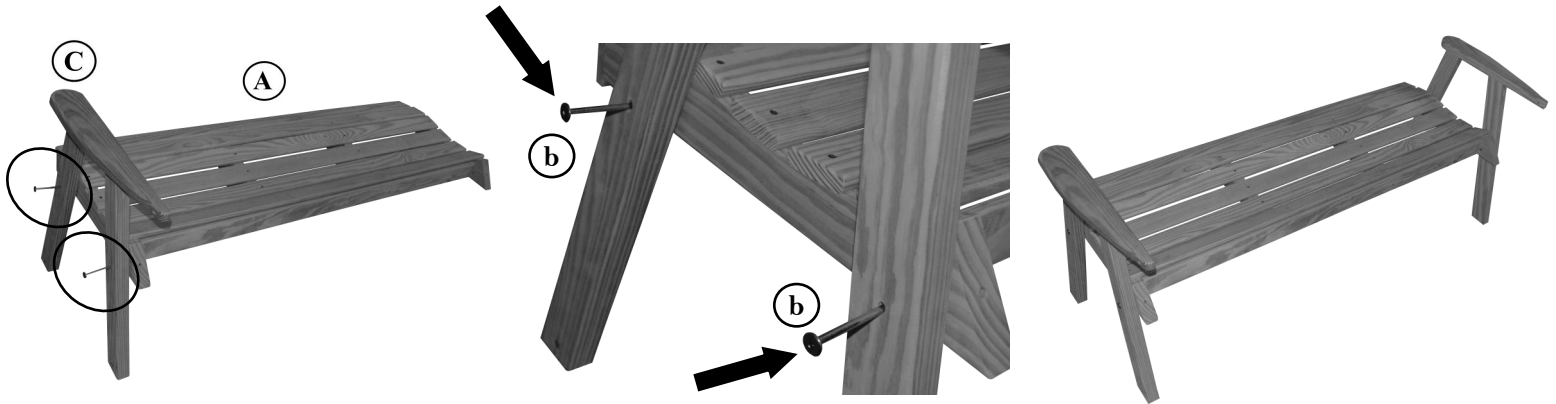

Photo 1

Photo 2

Photo 3

STEP 2

Hold the back in place between the armrests. (See photo 4.) Attach first to the seat using 4 3/4" bolts and then to the arms using 2" bolts. (See photo 5.) Make sure all bolts are fully tightened before moving on to Step 3. Use included Allen wrench to tighten the bolts.

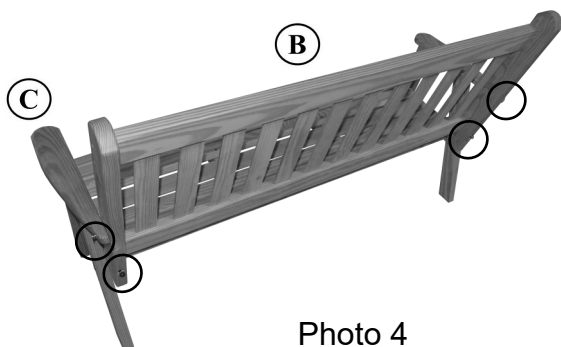

Photo 4

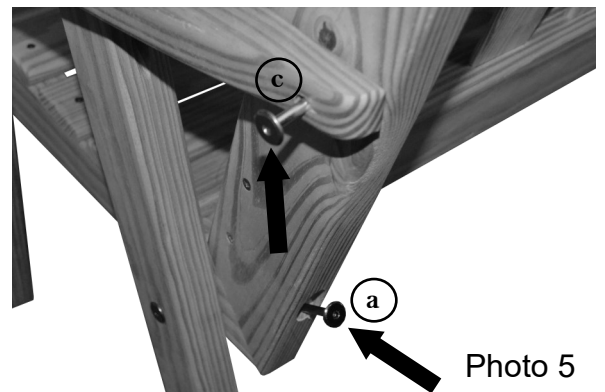

Photo 5

STEP 3

Attach the glider brackets to the inside of the bottoms of the legs using 1 $\frac{3}{4}$ " bolts. (See photos 6, 7 & 8.)
Note: The glider brackets are bent to an offset, make sure the unattached end swings clear of the leg.

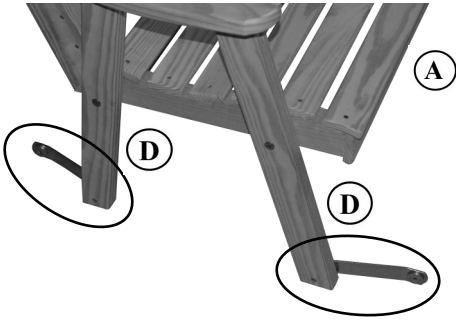

Photo 6

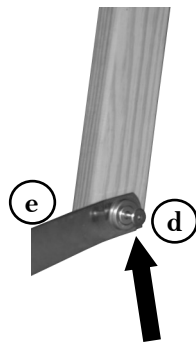

Photo 7

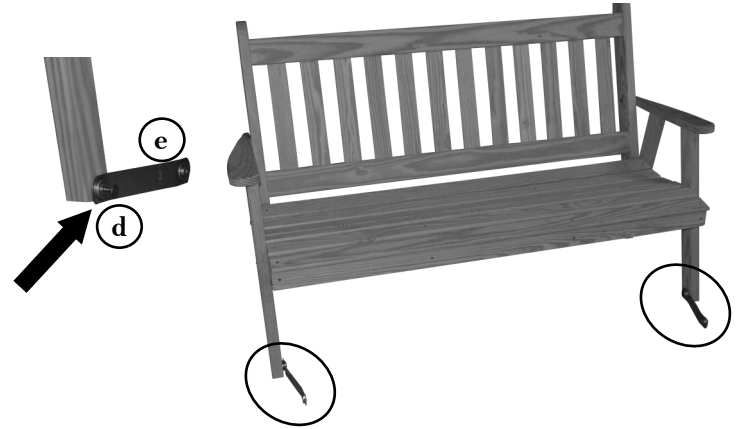

Photo 8

STEP 4

Attach the glider braces to the glider feet using 2 $\frac{1}{2}$ " wood screws as shown in photos 9 & 10. You will need the screwgun or drill with included square drive bit for this step. Predrilling the feet for the screws should not be necessary as the screws are self drilling however, if you wish to do so it may make it easier to drive the screws. (Note: If you predrill, use a bit no larger than $\frac{9}{64}$ ".)

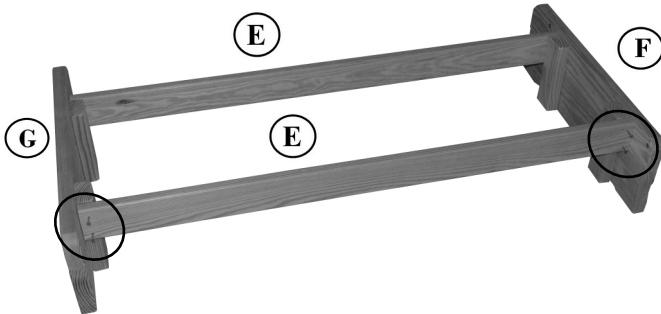

Photo 9

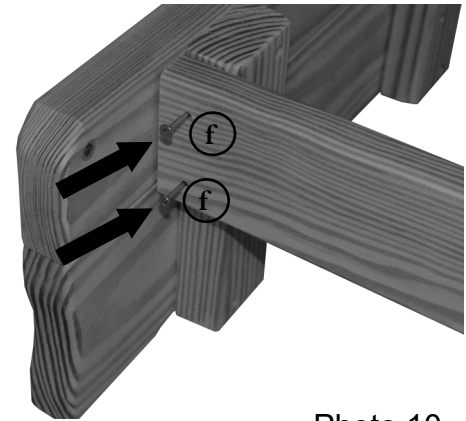

Photo 10

STEP 5

Push the glider feet/brace assembly underneath the glider seat (see photo 11) making sure the brace that is attached closest to the end of the feet is turned toward the front of the glider. Now attach the loose end of the glider brackets to the feet using 1 $\frac{3}{4}$ " bolts. (See photo 12.)



Photo 11

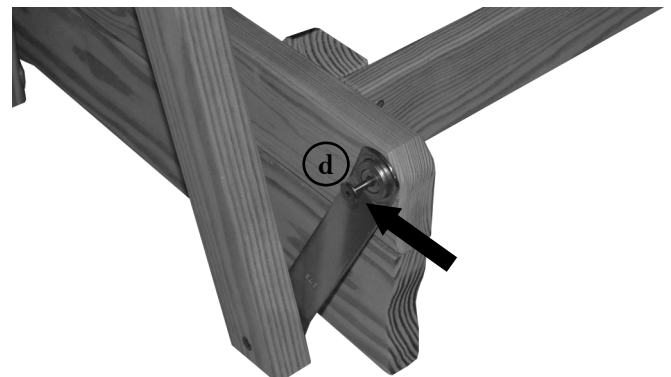

Photo 12