

ASSEMBLY INSTRUCTIONS

INSTRUCTIONS DE MONTAGE

GAMING FULL LOFT BED

LIT GAMING COMPLET GAMING

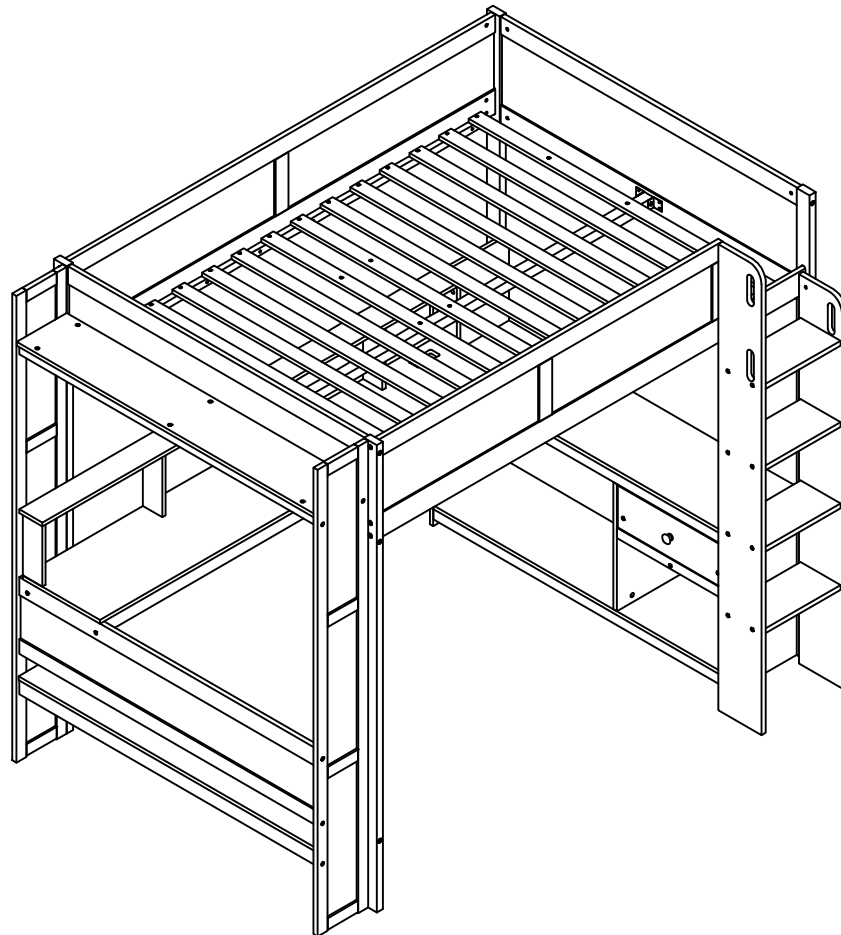

SAFETY WARNINGS AND GENERAL NOTES:

Follow the information on the warnings on the bunk bed end structure and on the carton. Do not remove the warning label from the bed. Always use the recommended size mattress on mattress support, or both, to help prevent the likelihood of entrapment or falls.

The top surface of the mattress must be at least 5*inch (127mm) below the upper edge of the guardrail.

Do not allow children under 6 years of age to use the upper bunk.

Periodically check and ensure the guardrail, ladder and other components are in their proper position, free from damage, and all connectors are tight.

Do not allow horseplay on or under beds.

Always prohibit jumping on the bed.

Prohibit more than one person on upper bunk.

Always use the ladder for entering and leaving the upper bunk.

Do not use substitute parts. Contact the manufacturer or dealer for replacement parts.

Use of a night-light may provide added safety precaution for a child using the upper bunk.

Always use guardrails on both long sides of the upper bunk.

If the bunk bed will be placed next to a wall, the guardrail that runs the full length of the bed should be placed against the wall to prevent entrapment between the bed and the wall.

The use of water or sleep flotation mattresses is prohibited.

STRANGULATION HAZARD-Never attach or hang items to any part of the bunk bed that are not designed for use with the bed.

Keep these instructions for future reference.

We recommend assembling your bunk bed on the shipping carton to protect your floor or carpet.

Be certain all staples are out of the box before beginning assembly on the shipping carton.

THIS BED IS DESIGNED TO USE A FULL MATTRESSES 54" WIDE X 74"-75" LONG WITH THE TOTAL THICKNESS NOT EXCEEDING 6" FOR UPPER BUNK, SURFACE OF MATTRESS MUST BE AT LEAST 5" (127MM) BELOW THE UPPER EDGE OF GUARDRAILS.

Replacement Parts:

Replacement Parts, including additional guardrails, may be obtained from any of our dealers.

AVERTISSEMENTS DE SÉCURITÉ ET REMARQUES GÉNÉRALES :

Suivez les informations sur les avertissements figurant sur la structure d'extrémité du lit superposé et sur le carton. Ne retirez pas l'étiquette d'avertissement du lit. Utilisez toujours le matelas de taille recommandée sur le support de matelas, ou les deux, pour éviter tout risque de coincement ou de chute.

La surface supérieure du matelas doit être à au moins 5*poüces (127 mm) sous le bord supérieur du garde-corps.

Ne laissez pas les enfants de moins de 6 ans utiliser le lit supérieur.

Vérifiez périodiquement et assurez-vous que le garde-corps, l'échelle et les autres composants sont dans leur bonne position, exempts de dommages et que tous les connecteurs sont bien serrés.

Ne permettez pas les chahuts sur ou sous les lits.

Interdisez toujours de sauter sur le lit.

Interdire plus d'une personne sur la couchette supérieure.

Utilisez toujours l'échelle pour entrer et sortir du lit supérieur.

N'utilisez pas de pièces de rechange. Contactez le fabricant ou le revendeur pour obtenir des pièces de rechange.

L'utilisation d'une veilleuse peut fournir une précaution supplémentaire en matière de sécurité pour un enfant utilisant le lit supérieur.

Utilisez toujours des garde-corps sur les deux côtés longs du lit supérieur.

Si le lit superposé doit être placé à côté d'un mur, le garde-corps qui s'étend sur toute la longueur du lit doit être placé contre le mur pour éviter tout coincement entre le lit et le mur.

L'utilisation de matelas flottants à eau ou de sommeil est interdite.

RISQUE D'ÉTRANGULATION - N'attachez ou ne suspendez jamais d'objets à une partie du lit superposé qui ne sont pas conçus pour être utilisés avec le lit.

Conservez ces instructions pour référence future.

Nous vous recommandons d'assembler votre lit superposé sur le carton d'expédition pour protéger votre sol ou votre tapis.

Assurez-vous que toutes les agrafes sont sorties de la boîte avant de commencer l'assemblage sur le carton d'expédition.

CE LIT EST CONÇU POUR UTILISER UN MATELAS COMPLET DE 54" DE LARGE X 74" - 75" DE LONG AVEC L'ÉPAISSEUR TOTALE NE DÉPASSANT PAS 6" POUR LE COUCHE SUPÉRIEUR, LA SURFACE DU MATELAS DOIT ÊTRE AU MOINS 5" (127 MM) EN DESSOUS DU BORD SUPÉRIEUR DES GARDE-CORPS.

Pièces de rechange :

Les pièces de rechange, y compris les garde-corps supplémentaires, peuvent être obtenues auprès de l'un de nos revendeurs .





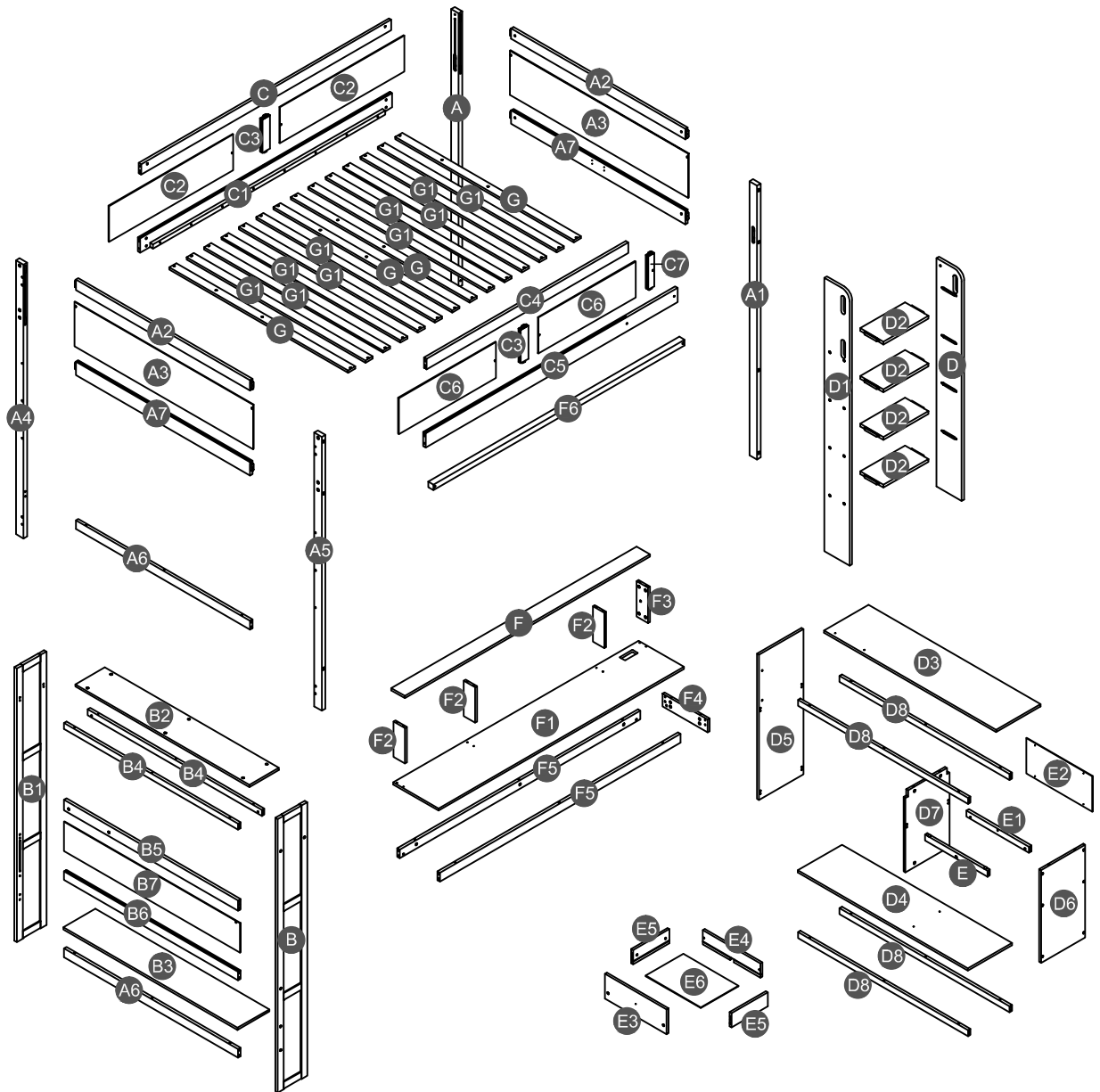





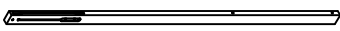

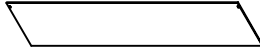
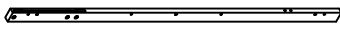

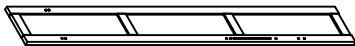
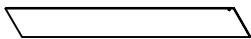

Detail View

Vue Détaillée

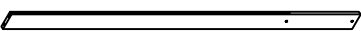
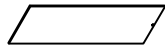

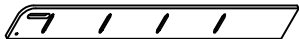
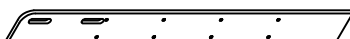
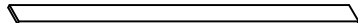



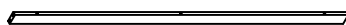
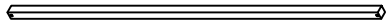







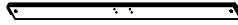
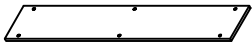
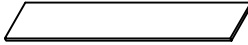

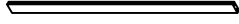





Part list (Box 1)

Liste des pièces (Boîte 1)

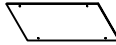
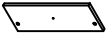
<p>A</p>  <p>Leg (Right back) - 1pc Pied (arrière droit)</p>	<p>A1</p>  <p>Leg (Right front) - 1pc Pied (Avant droit)</p>	<p>A3</p>  <p>Side panel HB/FB - 2pcs Panneau latéral HB/FB</p>
<p>A4</p>  <p>Leg (Left back) - 1pc Pied (Arrière gauche)</p>	<p>A5</p>  <p>Leg (Left front) - 1pc Pied (Avant gauche)</p>	<p>B</p>  <p>Frame HB (front) - 1pc Cadre HB (avant)</p>
<p>B1</p>  <p>Frame HB (back) - 1pc Cadre HB (arrière)</p>	<p>B7</p>  <p>Side panel - 1pc Panneau latéral</p>	<p>C</p>  <p>Long guard rail (back) - 1pc Garde-corps long (arrière)</p>
<p>C1</p>  <p>Side rail (back) - 1pc Rail latéral (arrière)</p>	<p>C2</p>  <p>Side panel (back) - 2pcs Panneau latéral (arrière)</p>	<p>C3</p>  <p>Vertical guard rail - 2pcs Garde-corps vertical</p>
<p>C4</p>  <p>Short guard rail (front) - 1pc Garde-corps court (avant)</p>	<p>C5</p>  <p>Side rail (front) - 1pc Rail latéral (avant)</p>	<p>C6</p>  <p>Side panel (front) - 2pcs Panneau latéral (avant)</p>
<p>C7</p>  <p>Vertical guard rail (front) - 1pc Garde-corps vertical (avant)</p>	<p>D</p>  <p>Ladder (right) - 1pc Échelle (droite)</p>	<p>D1</p>  <p>Ladder (left) - 1pc Échelle (gauche)</p>
<p>F</p>  <p>Top panel - 1pc Panneau supérieur</p>	<p>F1</p>  <p>Top table - 1pc Table haute</p>	<p>F2</p>  <p>Panel support - 3pcs Support de panneau</p>
<p>F3</p>  <p>Panel support (right) - 1pc Support de panneau (droite)</p>	<p>F4</p>  <p>Support - 1pc Support</p>	<p>F5</p>  <p>Horizontal bar - 2pcs Barre horizontale</p>
<p>F6</p>  <p>Lower support slat - 1pc Latte de support inférieure</p>		











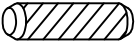
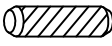
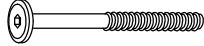
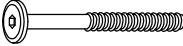
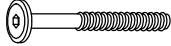





Part list & Hardware list (Box 2)



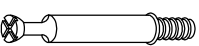

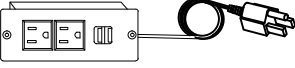

Liste des pièces & liste du matériel (Boîte 2)

<p>A2</p>  <p>Upper horizontal bar HB/FB- 2pcs Barre horizontale supérieur HB/FB</p>	<p>A6</p>  <p>Lower horizontal bar HB - 2pcs Barre horizontale inférieure HB</p>	<p>A7</p>  <p>Divider horizontal bar HB/FB-2pcs Barre de séparation horizontale HB</p>
<p>B2</p>  <p>Top panel - 1pc Panneau supérieur</p>	<p>B3</p>  <p>Shelf panel - 1pc Panneau d'étagère</p>	<p>B4</p>  <p>Upper horizontal bar - 2pcs Barre horizontale supérieur</p>
<p>B5</p>  <p>Divider horizontal bar - 1pc Barre de séparation horizontale</p>	<p>B6</p>  <p>Lower horizontal bar - 1pc Barre horizontale inférieure</p>	<p>D2</p>  <p>Step ladder - 4pcs Escabeau</p>
<p>D3</p>  <p>Top panel - 1pc Panneau supérieur</p>	<p>D4</p>  <p>Bottom panel - 1pc Panneau inférieur</p>	<p>D5</p>  <p>Side panel (left) - 1pc Panneau latéral (gauche)</p>
<p>D6</p>  <p>Side panel (right) - 1pc Panneau latéral (droit)</p>	<p>D7</p>  <p>Divider panel - 1pc Panneau séparateur</p>	<p>D8</p>  <p>Horizontal bar - 4pcs Barre horizontale</p>
<p>E</p>  <p>Horizontal bar (front) - 1pc Barre horizontale (avant)</p>	<p>E1</p>  <p>Horizontal bar (back) - 1pc Barre horizontale (arrière)</p>	<p>E2</p>  <p>Back panel - 1pc Panneau arrière</p>
<p>E3</p>  <p>Front drawer panel - 1pc Panneau de tiroir avant</p>	<p>E4</p>  <p>Back drawer panel - 1pc Panneau de tiroir arrière</p>	<p>E5</p>  <p>Left / right drawer panel - 2pcs Panneau de tiroir gauche/droit</p>
<p>E6</p>  <p>Drawer bottom - 1pc Fond de tiroir</p>	<p>G</p>  <p>Slats - 4pcs Lattes</p>	<p>G1</p>  <p>Slats - 10pcs Lattes</p>

Hardware List (Box 2)

Liste du matériel (Boîte 2)

1  Ø10*40mm	2  Ø8*30mm	3  (Ø15)1/4"*100mm
Wood dowel (3pcs) Cheville en bois	Wood dowel (42pcs) Cheville en bois	Hex-Head bolts (14pcs) Boulons à tête hexagonale
4  (Ø15)1/4"*80mm	5  (Ø12)1/4"*60mm	6  1/4"*15 (9.5mm)
Hex-Head bolts (11pcs) Boulons à tête hexagonale	Hex-Head bolts (50pcs) Boulons à tête hexagonale	Horizontal-Hole bolts(75pcs) Boulons à trou horizontal
7  (Ø12)1/4"*50mm	8  (Ø12)1/4"*40mm	9  Ø4*30mm
Hex-Head bolts (8pcs) Boulons à tête hexagonale	Hex-Head bolts (6pcs) Boulons à tête hexagonale	Wood screws (32pcs) Vis
10  Ø3.5*15mm	11  Ø3.5*15mm	12  Ø38*31mm
Wood screws (37pcs) Vis	Wood screws (5pcs) Vis	Pine Knob (1pc) Bouton en pin
13  3/16"*25mm	14  313*58*28 mm	15  295*30mm
Ph zinc(Knob) (1pc) Ph zinc (bouton)	Lower slider drawer (1pc) Tiroir coulissant inférieur	Upper slider drawer (1pc) Tiroir coulissant supérieur
16  Ø7"*35mm	17  Ø14*9mm	18  40*17*17*1.6mm
Cam lock (50pcs) Serrure à came	Cam lock (50pcs) Serrure à came	Metal bracket (2pcs) Support métallique
19  L1900mm	20  1500*43*47*125mm	21  2000mm
Led light (1pc) Lumière LED	USB output 5.1VDC-HG2000-SU(1pc) Sortie USB 5,1 V CC-HG2000-SU	Adapter and wire strip (1pc) Adaptateur et dénudeur de fil

22  L124*40*7mm	23  22*10*6mm	24  116*40*27mm
Remote led light (1pc) Lumière LED à distance	Clamp plastic (1pc) Pince en plastique	Metal bracket (2pcs) Support métallique
25  (Ø12)1/4"*40mm	26  (Ø13)1/4"*14mm	27  (1/4")4.5*58mm
Hex-Head bolts (2pcs) Boulons à tête hexagonale	Connect bolt (4pcs) Connecter le boulon	Allen key (2pcs) Clé Allen
28  75*20*2 mm Metal bracket (4pcs) /Support métallique		

ASSEMBLY TOOLS REQUIRED (NOT INCLUDED)
OUTILS D'ASSEMBLAGE REQUIS (NON INCLUS)



PLEASE BE CAREFUL DO NOT DAMAGE THE HOLE POSITION WHEN YOU USE POWER TOOLS !

NE PAS UTILISEZ DES OUTILS ÉLECTRIQUES POUR ASSEMBLER CE PRODUIT !

STEP 1:

ÉTAPE

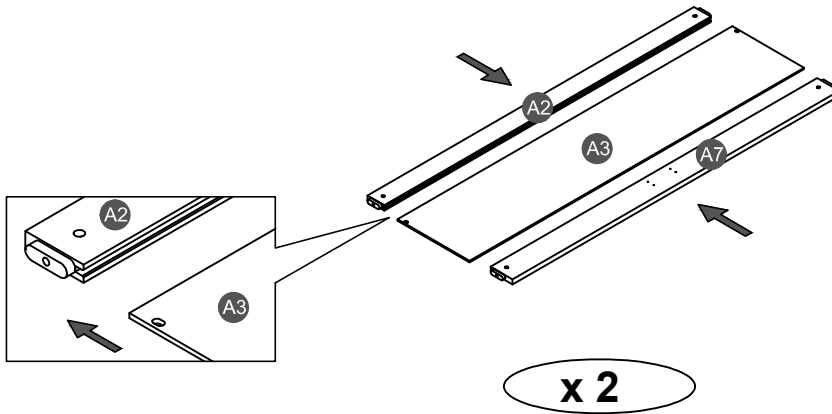

STEP 2:

ÉTAPE

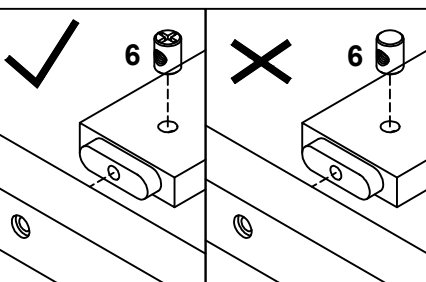
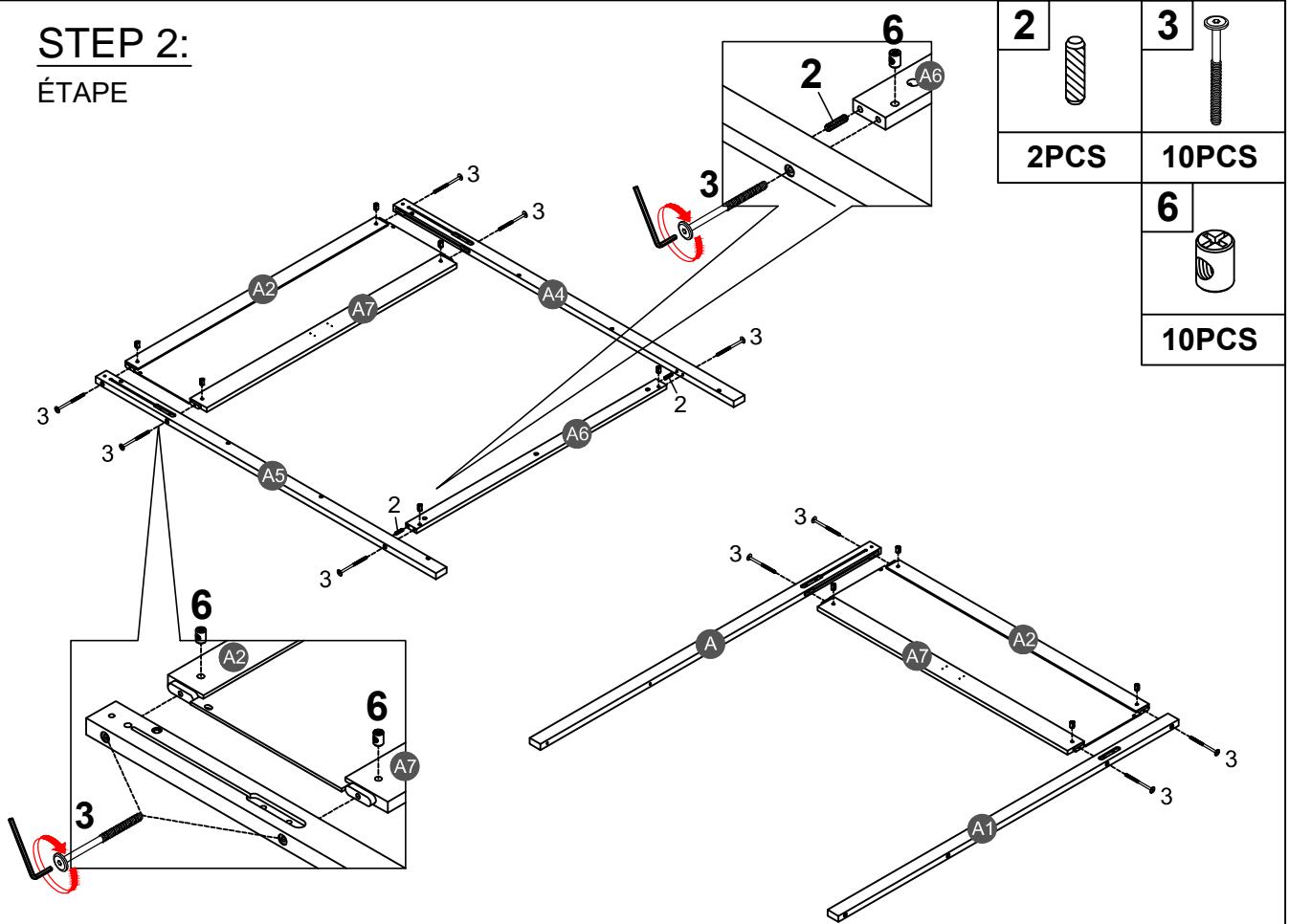

Note: Part 6 will face up with the "x" mark on it, otherwise it cannot be tightened

Remarque: La pièce 6 sera face vers le haut avec la marque "x", sinon elle ne peut pas être serrée.

STEP 3:
ÉTAPE

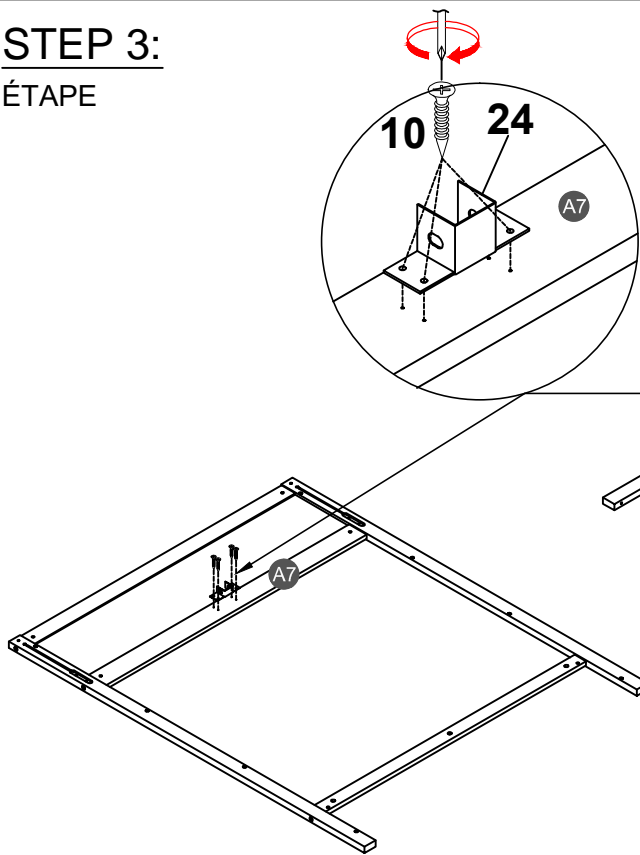

10		24	
8PCS		2PCS	

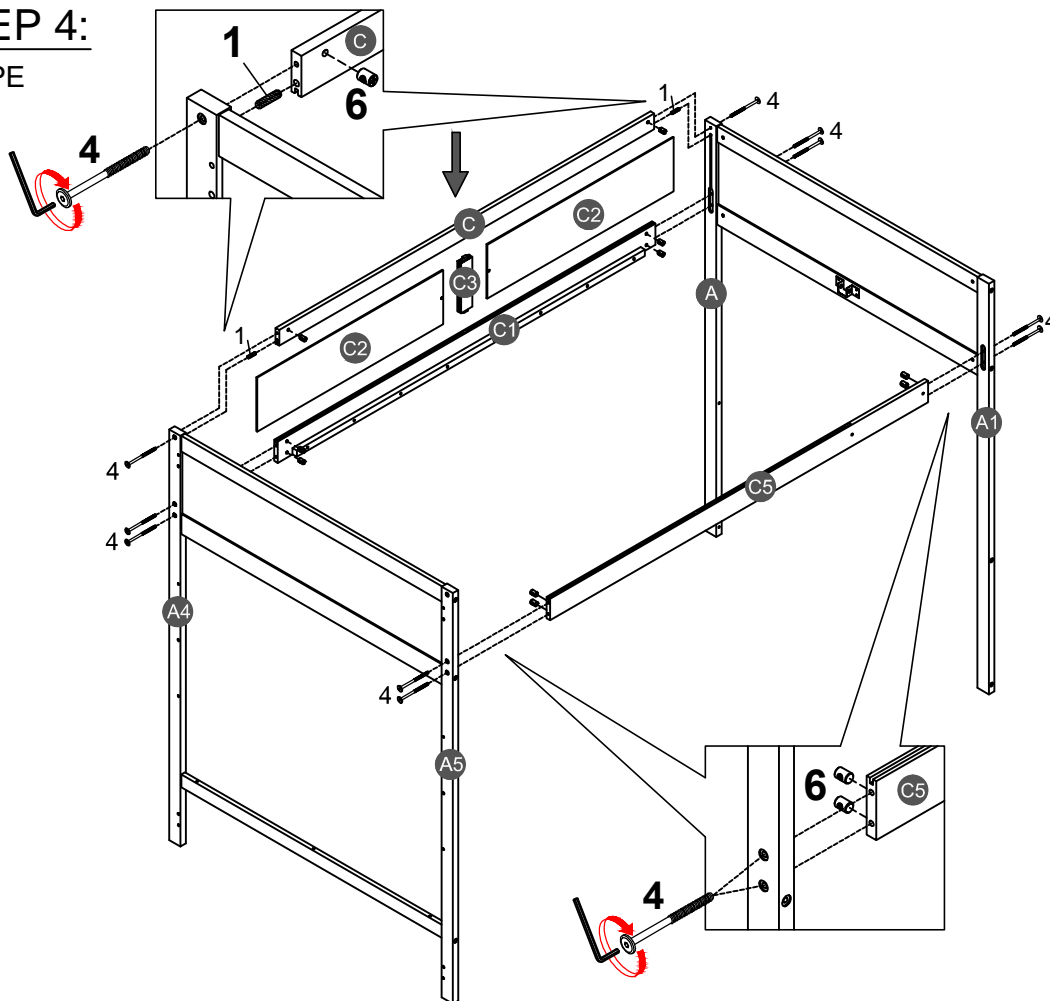

STEP 4:
ÉTAPE

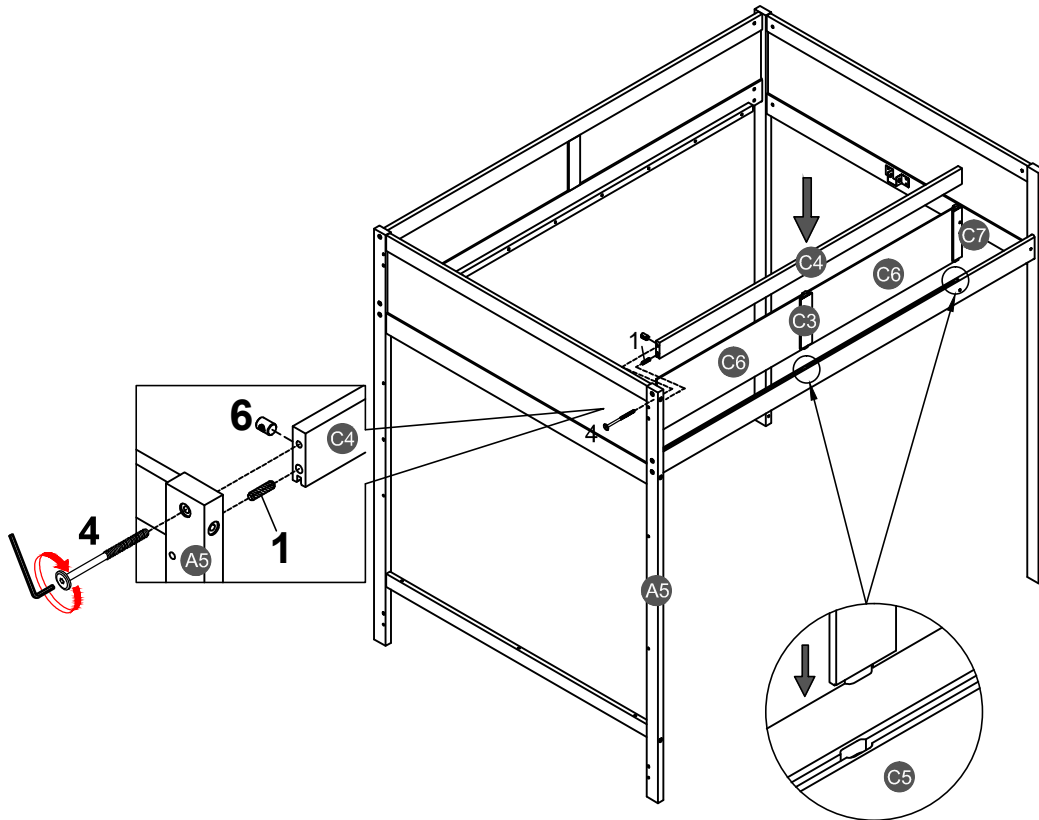

1		2PCS
4		10PCS
6		10PCS

STEP 5:
ÉTAPE



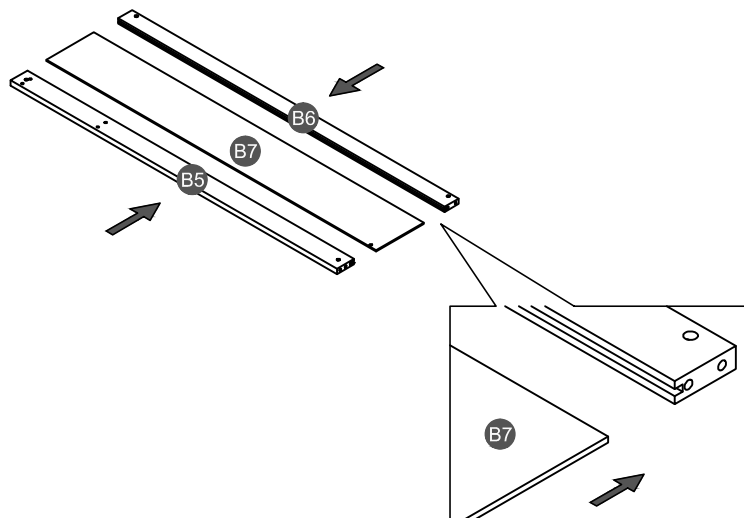

- | | |
|---|---|
| 1 |  |
| | 1PC |
| 4 |  |
| | 1PC |
| 6 |  |
| | 1PC |

STEP 6:
ÉTAPE



STEP 7:

ÉTAPE

2 	5 	6 
10PCS	10PCS	10PCS

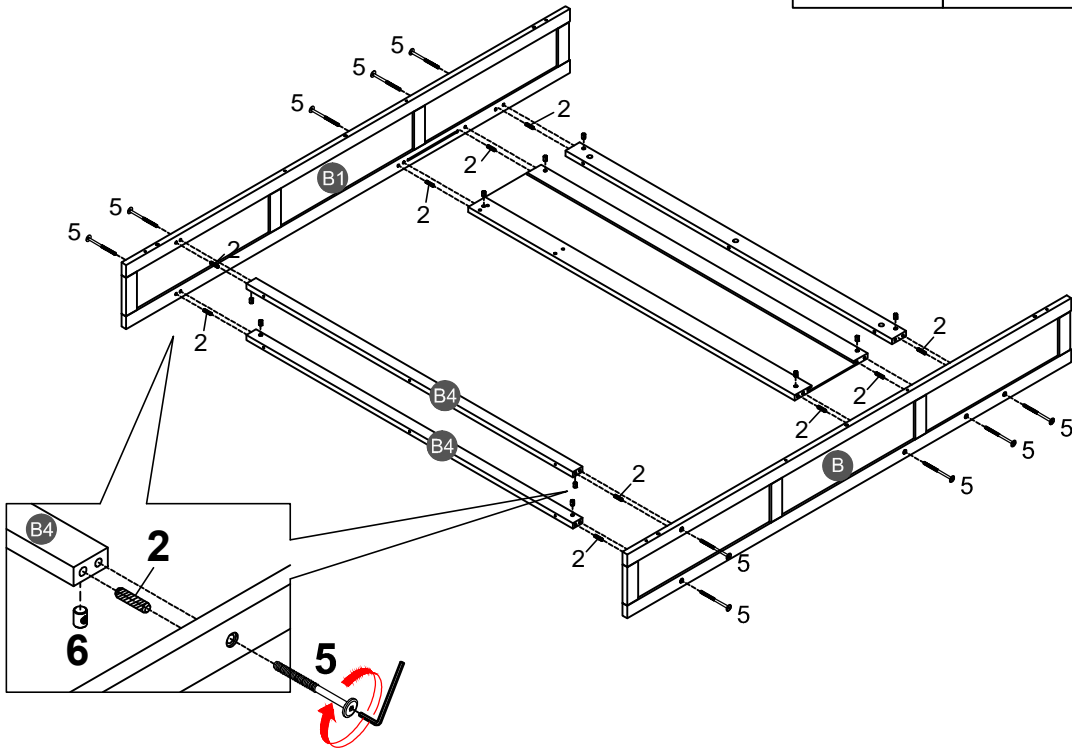

STEP 8:

ÉTAPE

8 
6PCS

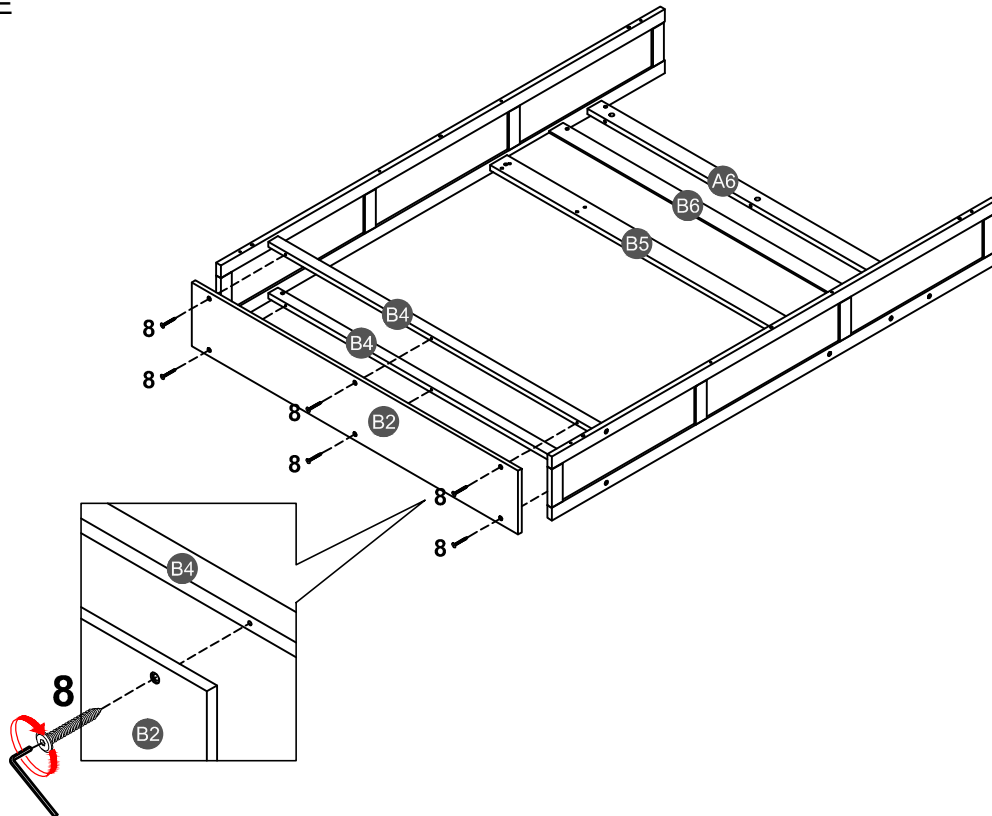



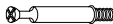

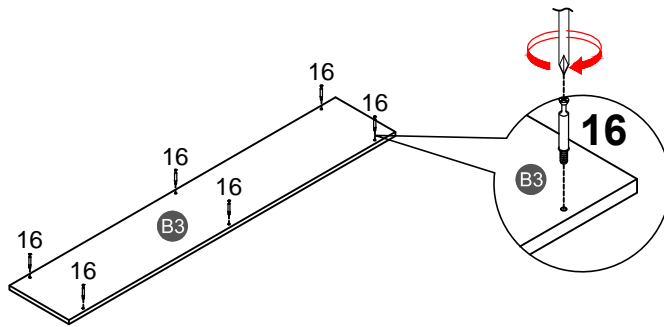
STEP 9:
ÉTAPE

16

6PCS



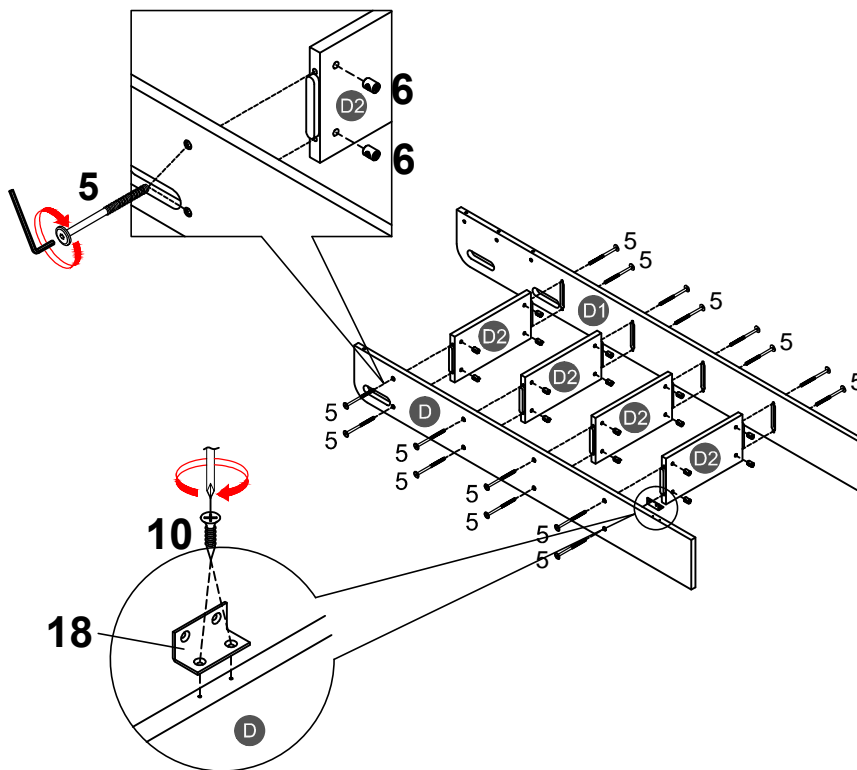

STEP 10:
ÉTAPE

5		6		10		18	
16PCS		16PCS		2PCS		1PC	

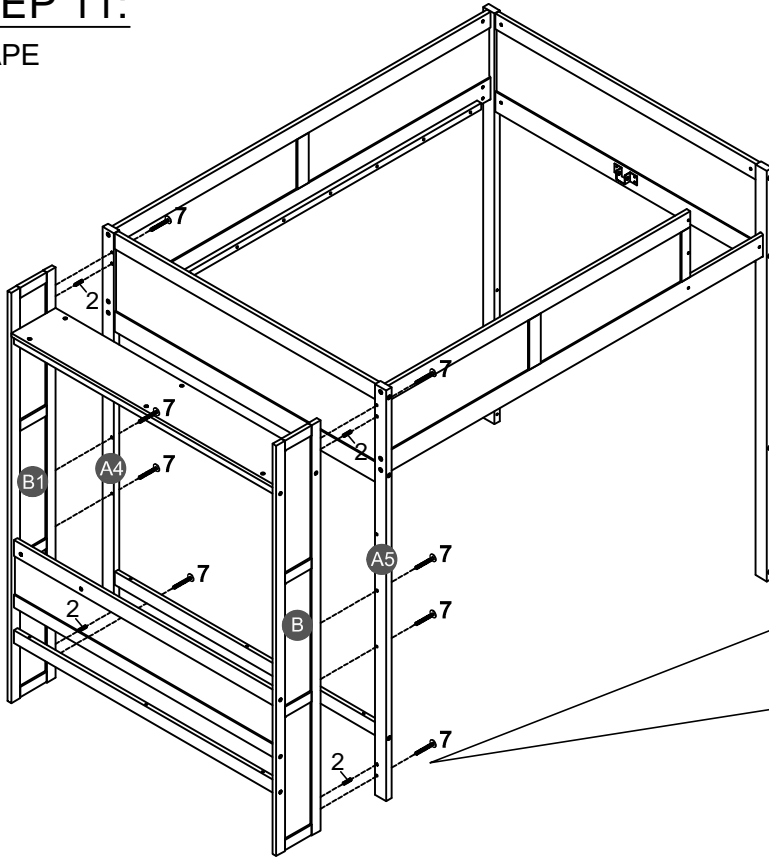

STEP 11:
ÉTAPE



2		7	
6PCS		8PCS	

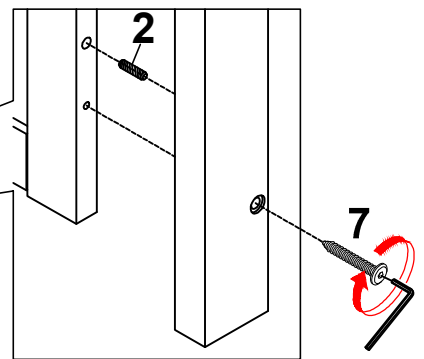

STEP 12:
ÉTAPE

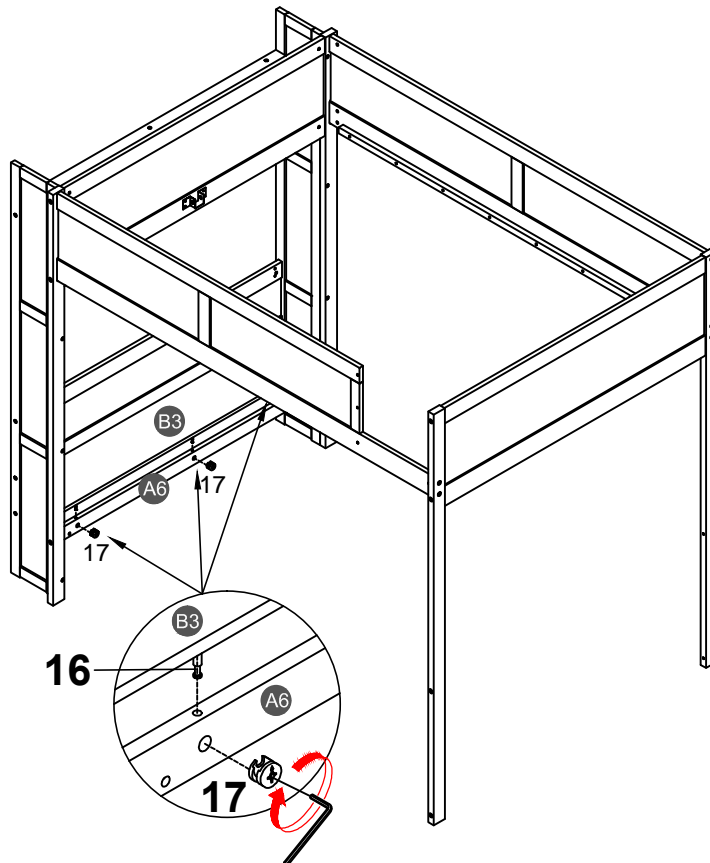

17	
6PCS	

STEP 13:

ÉTAPE

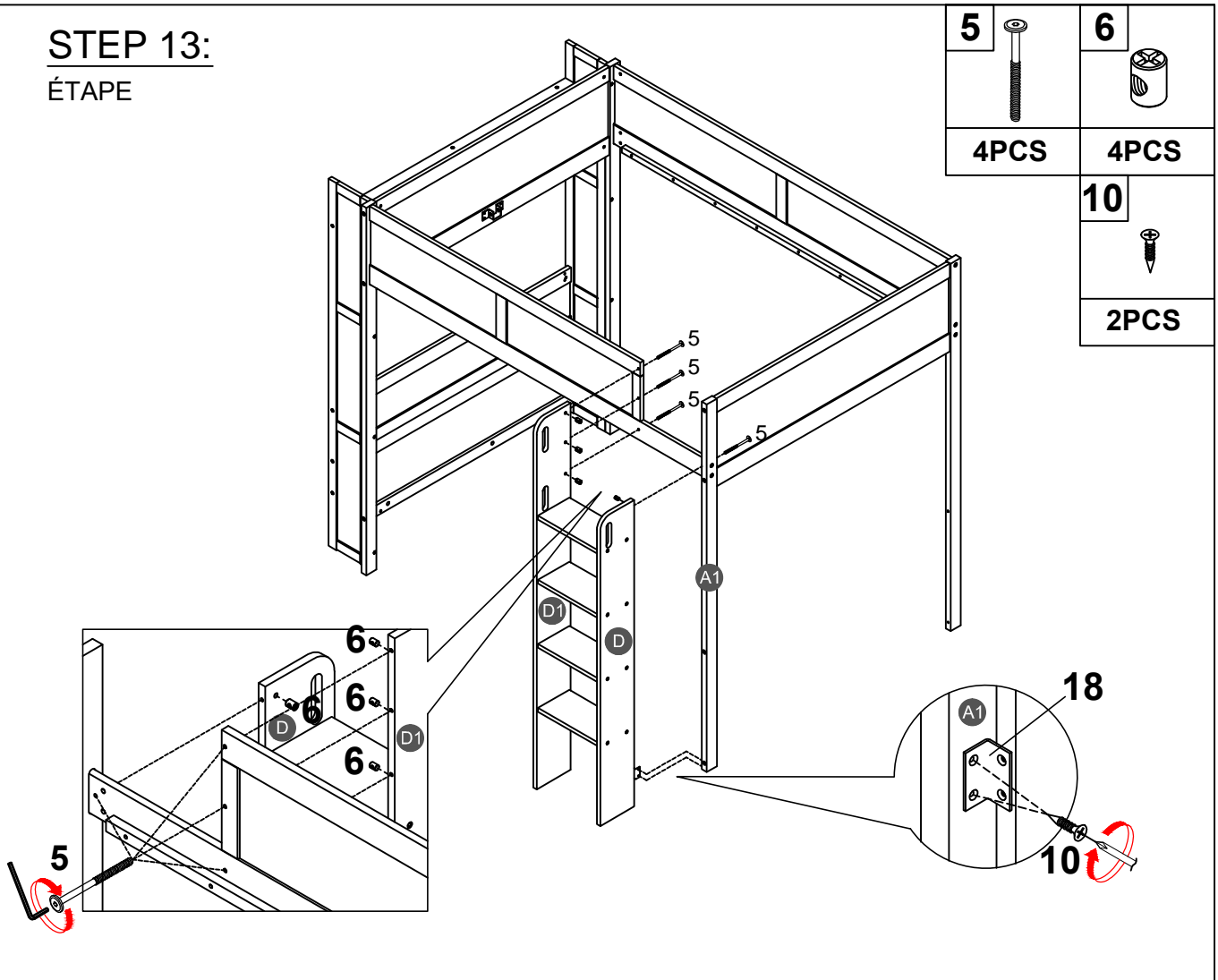

STEP 14:

ÉTAPE

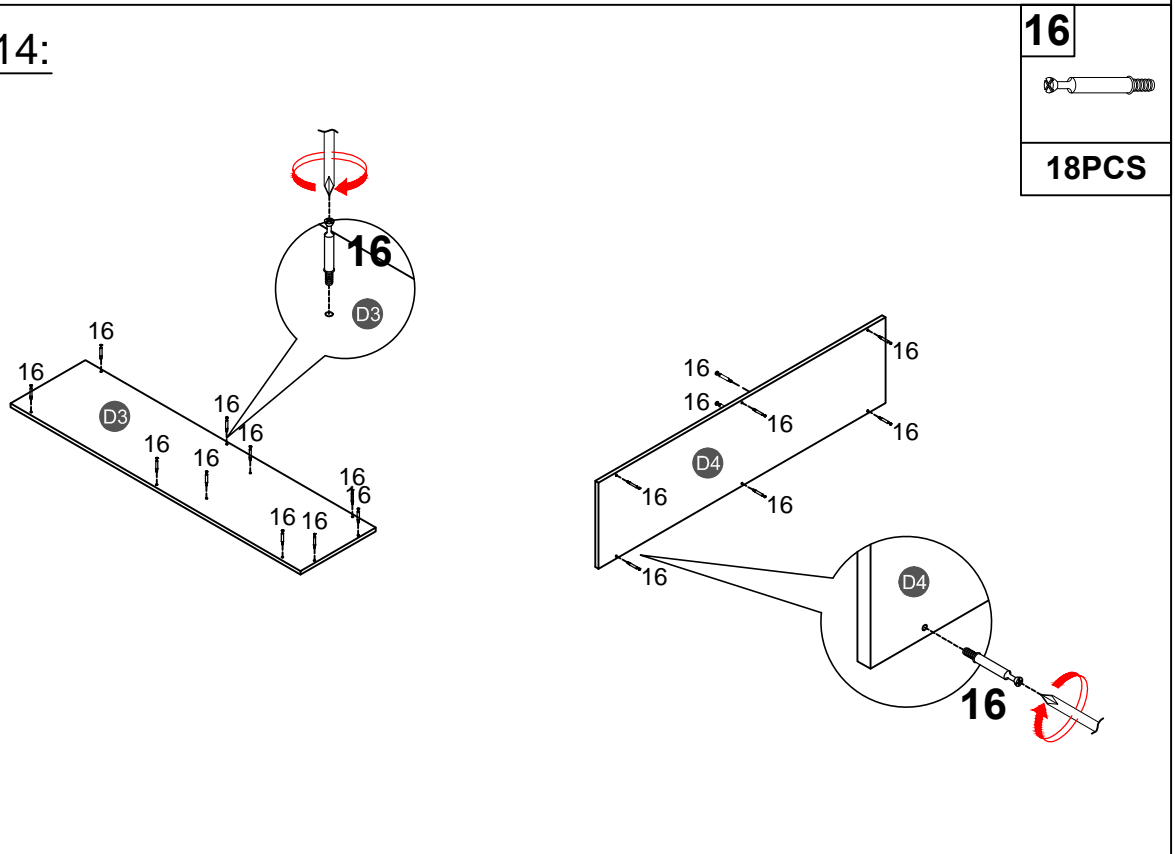

STEP 15:

ÉTAPE

17



6PCS

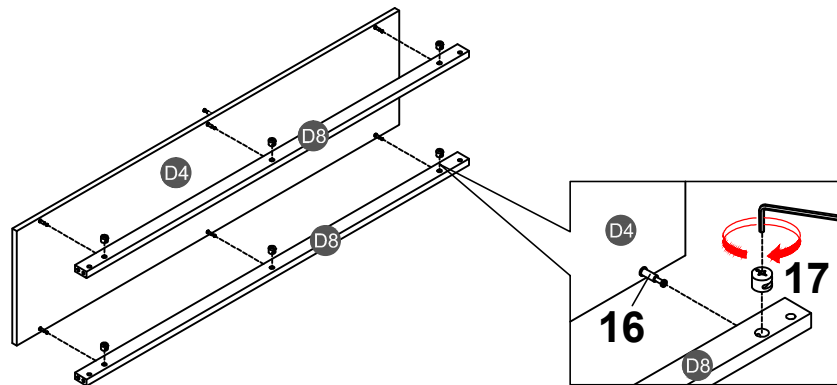

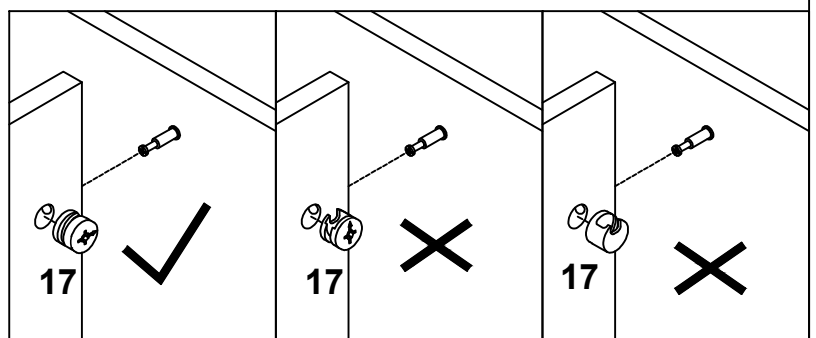

Note: Place hardware #17 with the "X" face outward, and make sure that the arrowhead is upward. Then, place hardware #17 into the hole of hardware #16 and tighten it clockwise with a hand screwdriver. (Please do NOT use an electric screwdriver.)

Remarque : placez la quincaillerie #17 avec la face « X » vers l'extérieur, et assurez-vous que la pointe de la flèche est vers le haut. Ensuite, placez le matériel #17 dans le trou de la quincaillerie #16 et serrez-le dans le sens des aiguilles d'une montre avec un tournevis à main. (Veuillez ne PAS utiliser de tournevis électrique.)

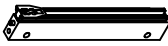

STEP 16:
ÉTAPE

5 	6 	14 
2PCS	2PCS	1PC

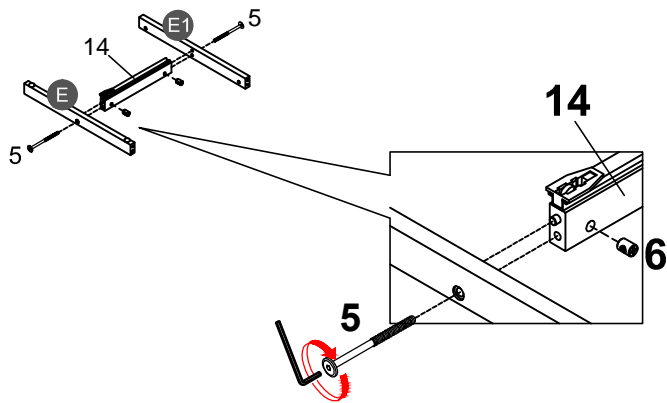

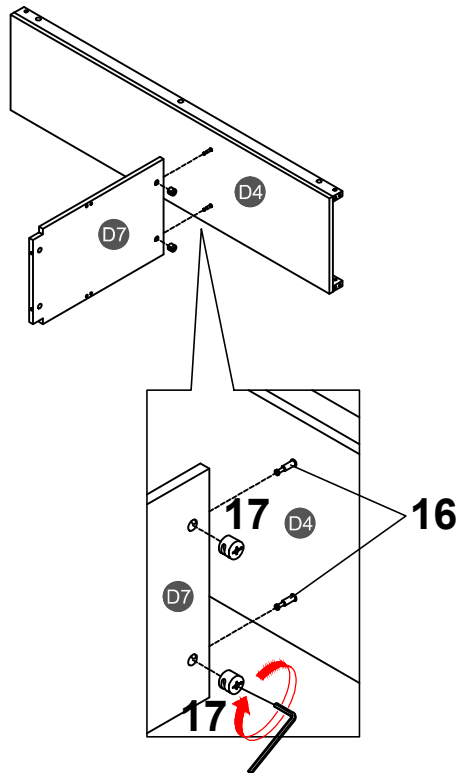

STEP 17:
ÉTAPE

17 
2PCS



STEP 18:

ÉTAPE

2 	5 	6 
12PCS	8PCS	8PCS

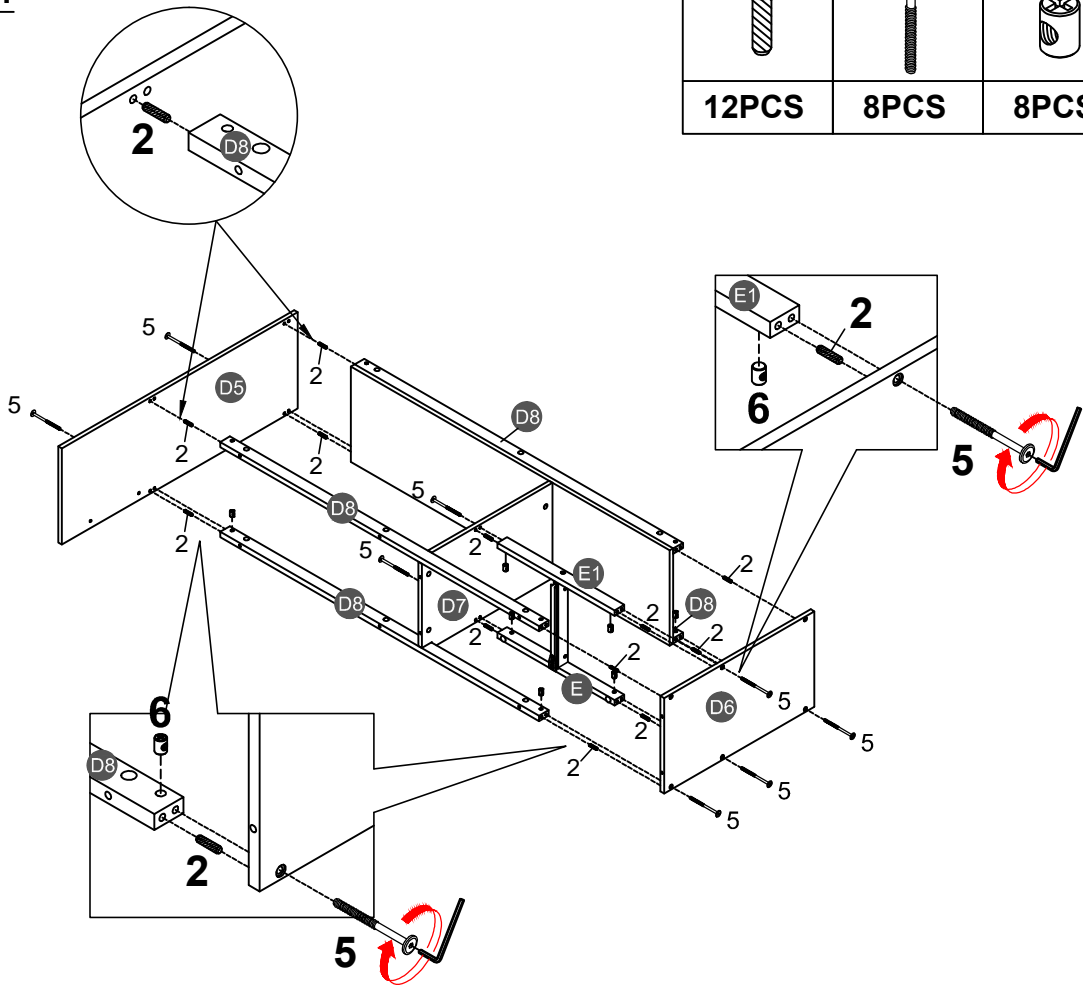

STEP 19:

ÉTAPE

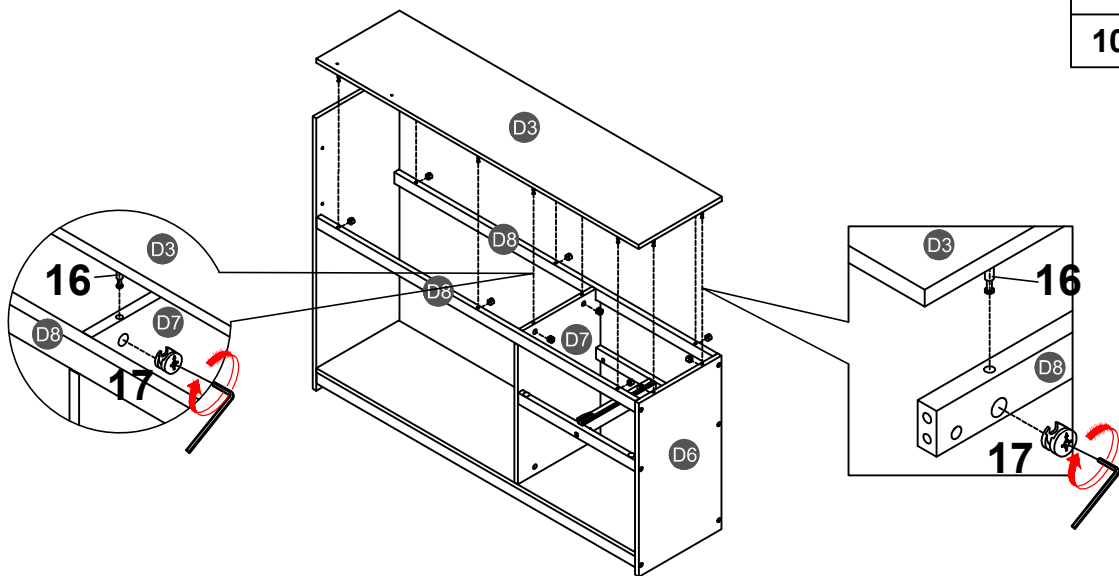

17 
10PCS

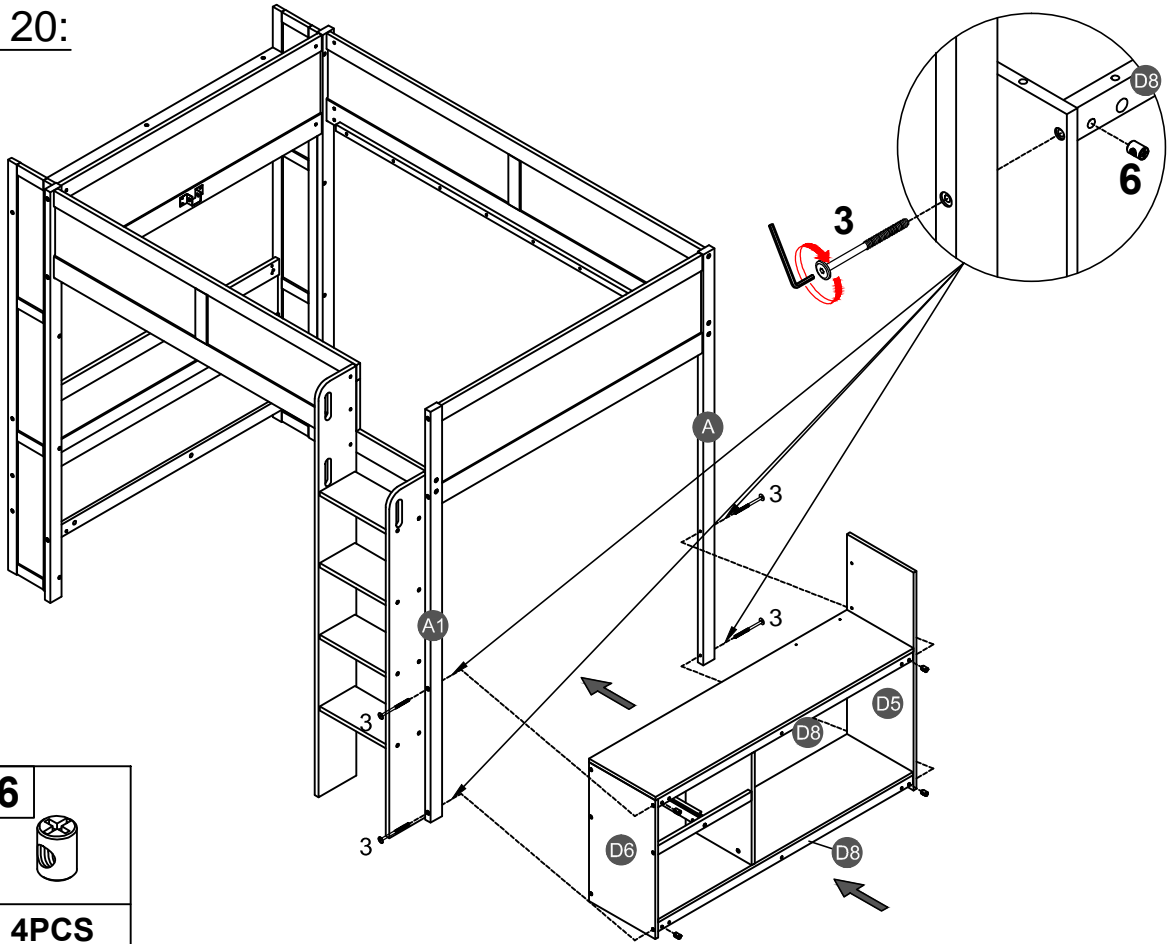

STEP 20:

ÉTAPE





3		6	
4PCS		4PCS	

STEP 21:

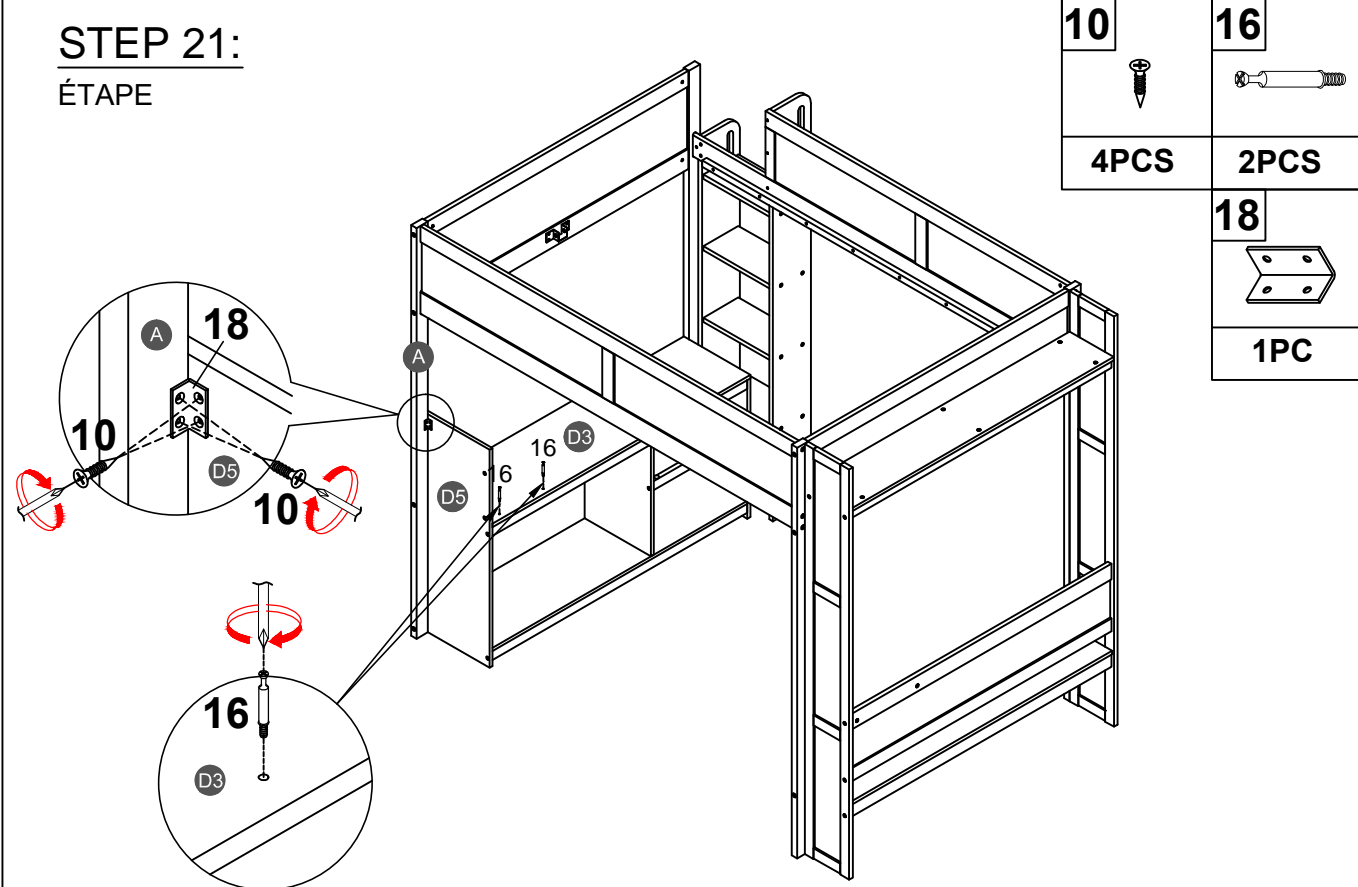
ÉTAPE

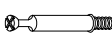

10		16	
4PCS		2PCS	
		18	
		1PC	

STEP 22:

ÉTAPE

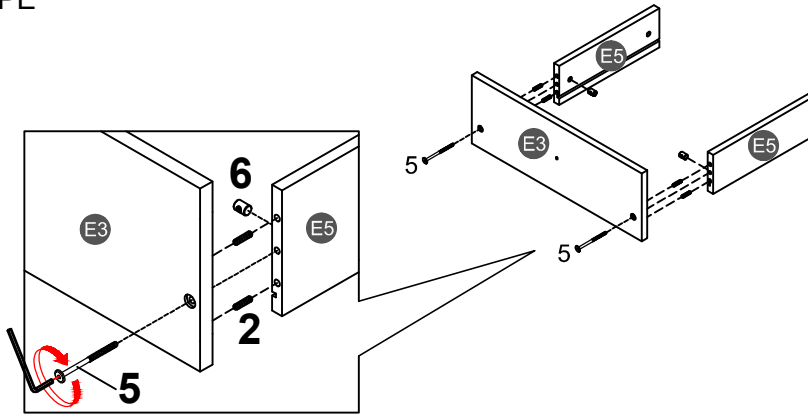

2		5	
4PCS		2PCS	
		6	
		2PCS	

STEP 23:

ÉTAPE

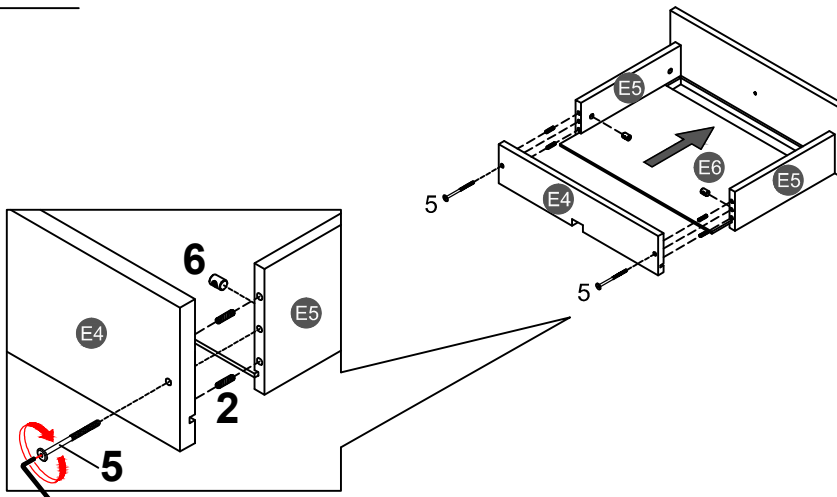

2		5	
4PCS		2PCS	
		6	
		2PCS	

STEP 24:

ÉTAPE

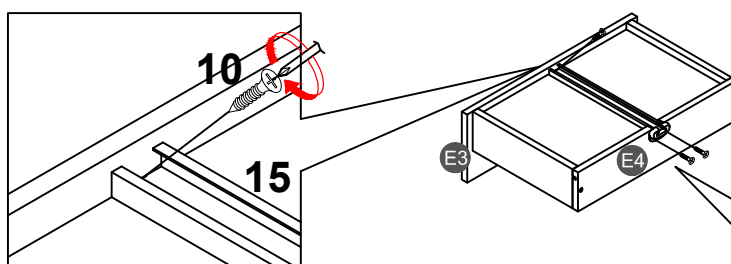

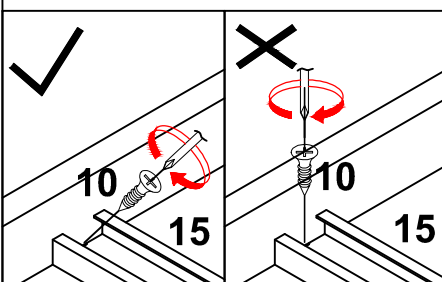
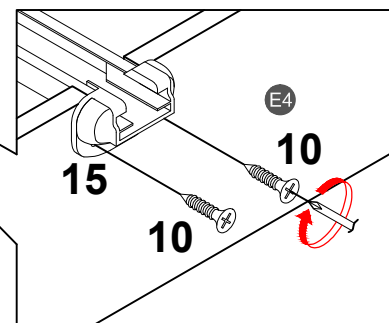

10		15	
3PCS		1PC	



STEP 25:

ÉTAPE

12		13	
1PC		1PC	

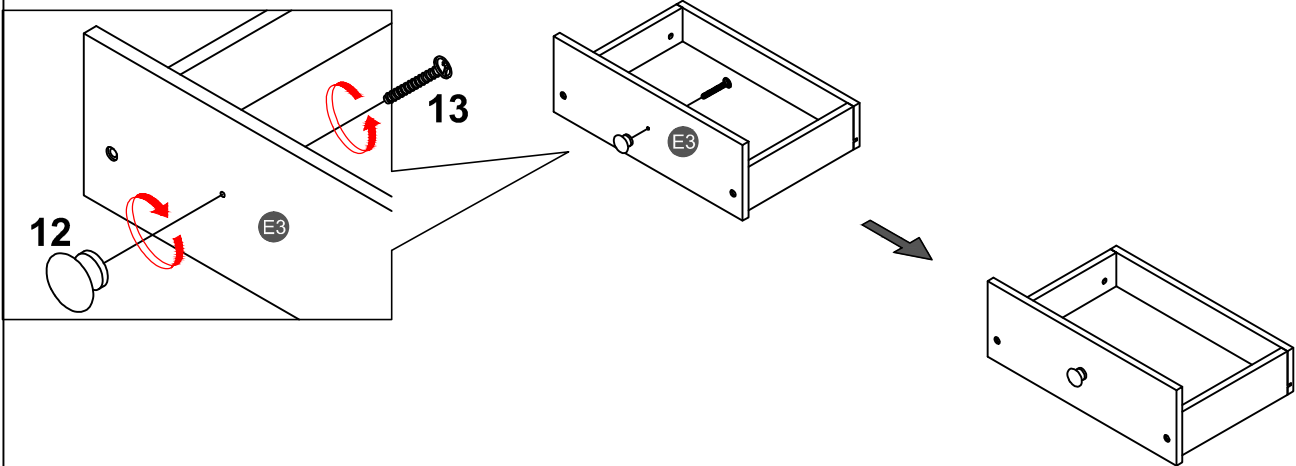

STEP 26:

ÉTAPE

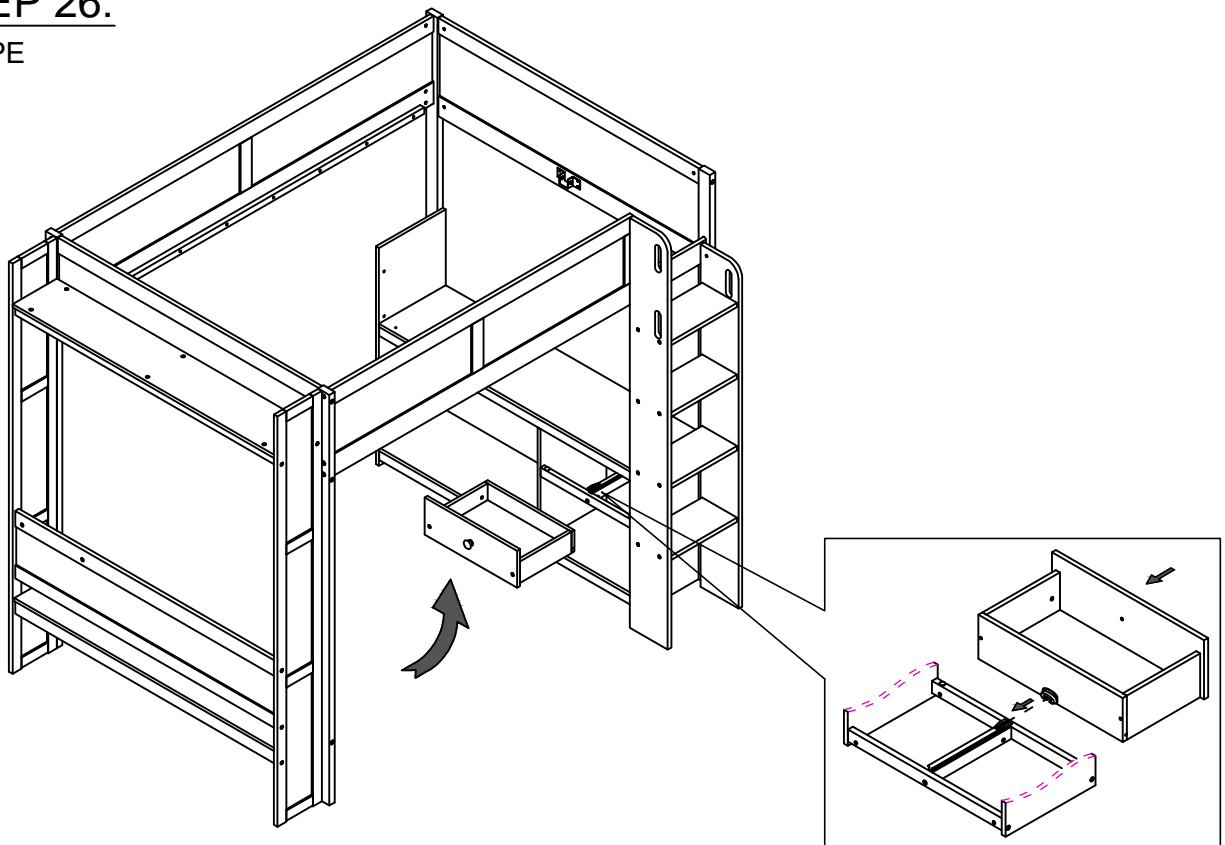

Align the slide rail at the bottom of the drawer and ensure it is secure, then push the drawer in firmly to make the slide rails smoothly on the track.

Alignez le rail coulissant au bas du tiroir et assurez-vous qu'il est bien fixé, puis poussez fermement le tiroir pour que les rails coulissants s'insèrent en douceur sur la piste.

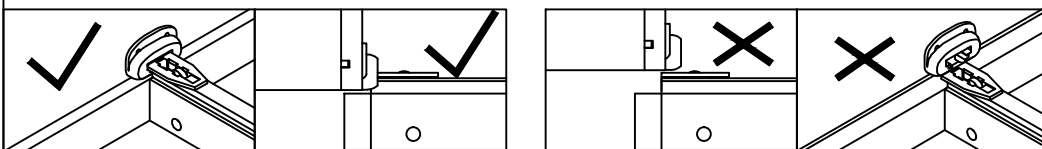

STEP 27:

ÉTAPE

11



4PCS

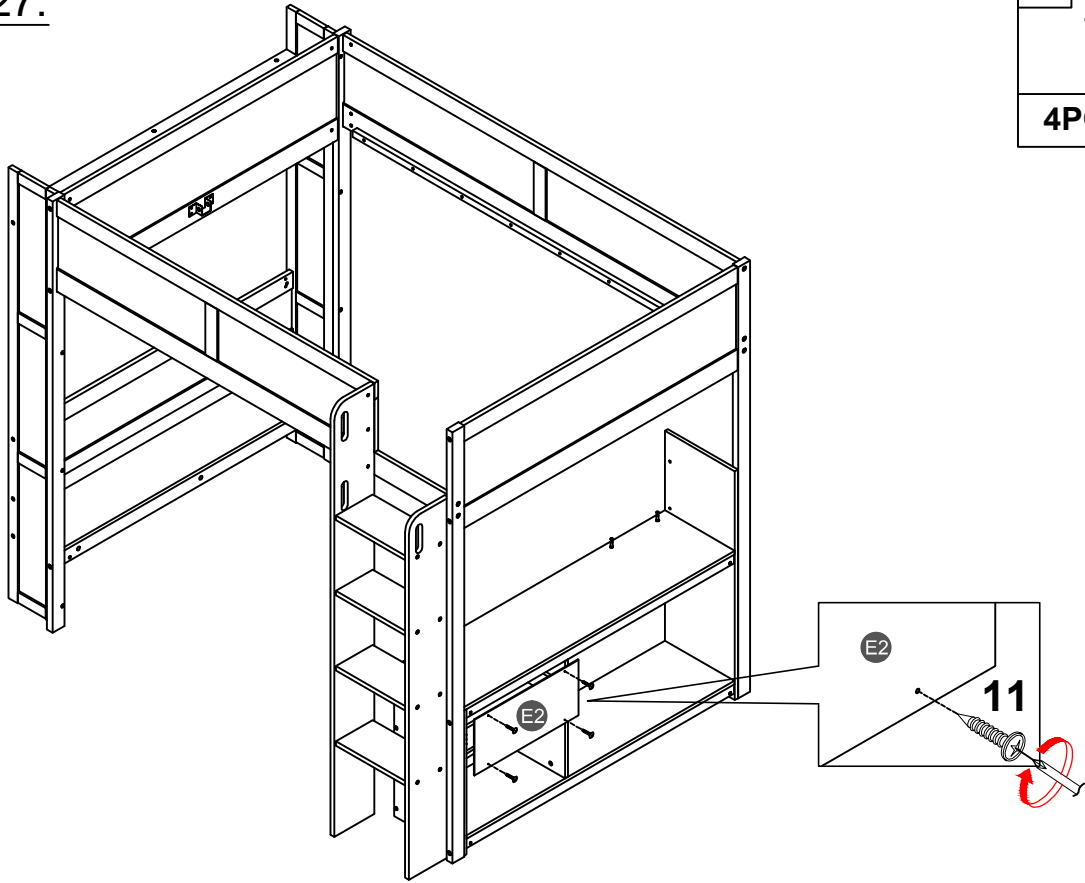

STEP 28:

ÉTAPE

16

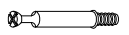

16PCS

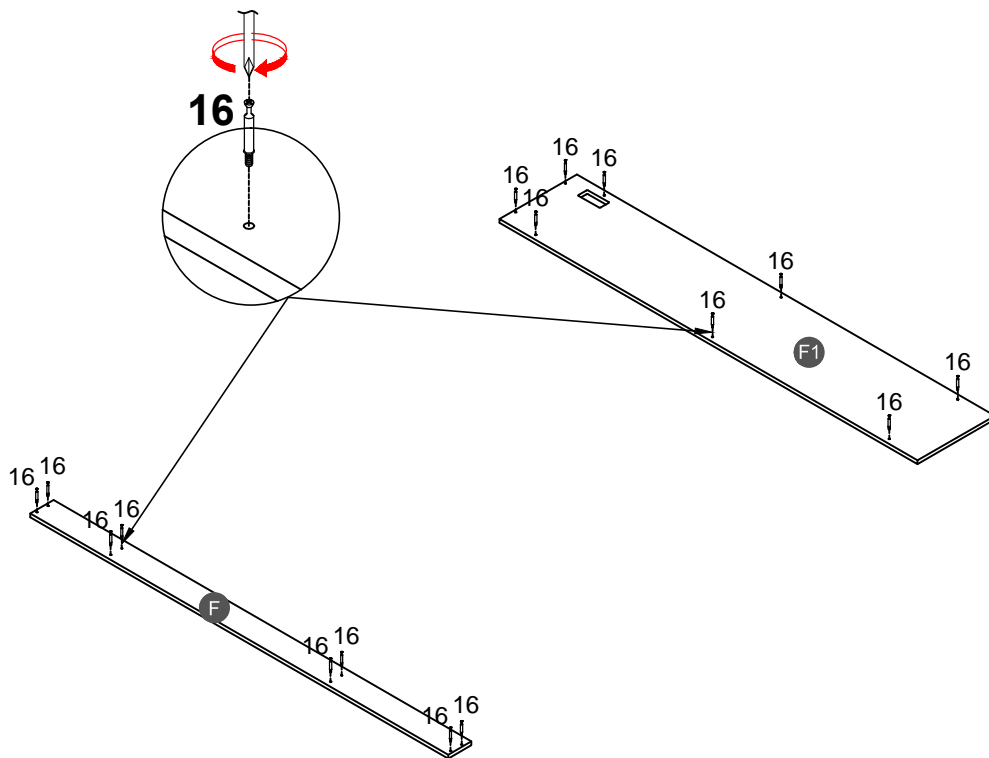

STEP 29:

ÉTAPE

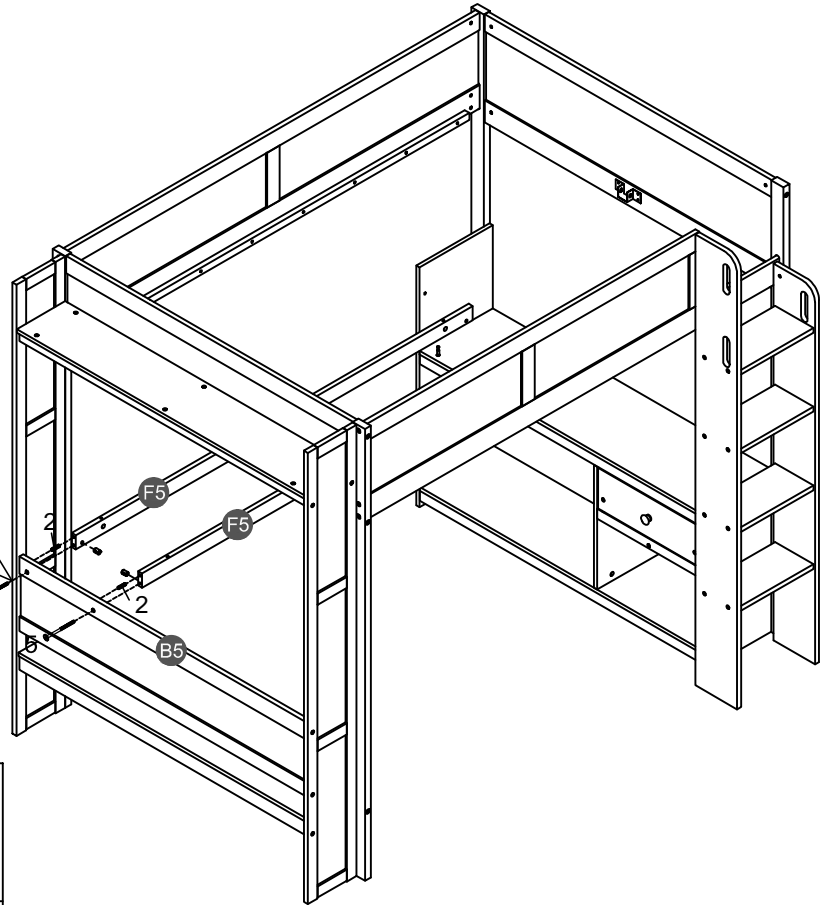
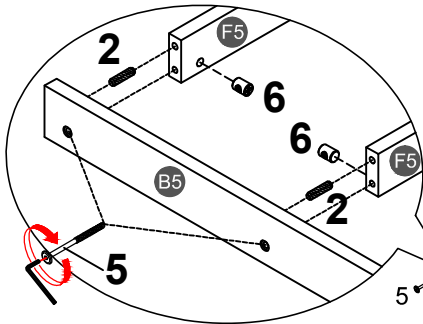

2		5		6	
2PCS		2PCS		2PCS	

STEP 30:

ÉTAPE

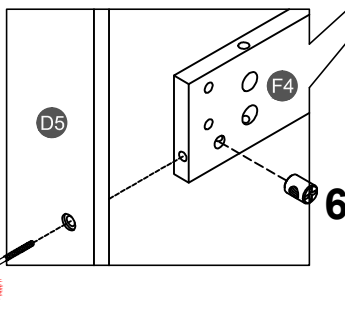
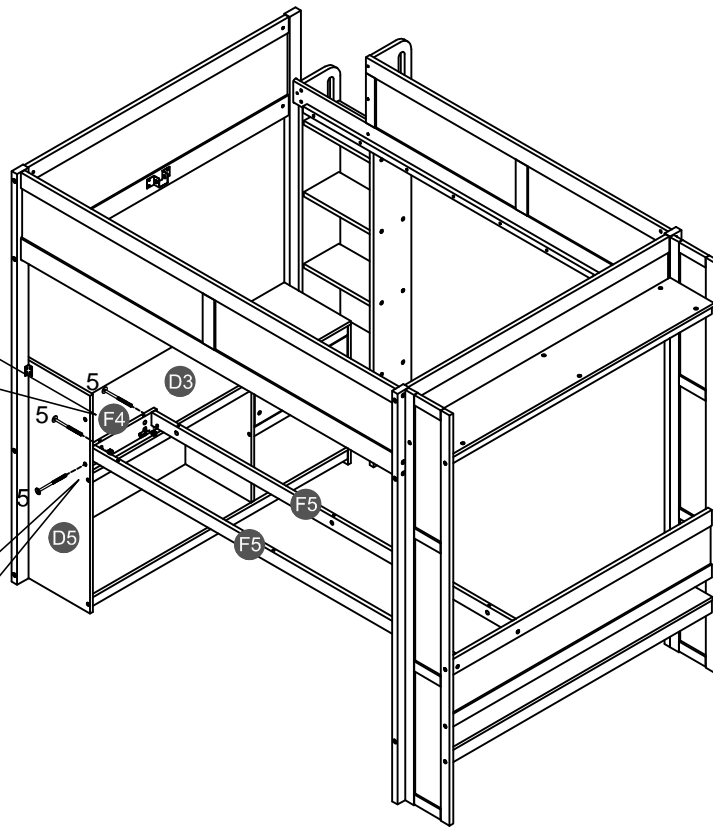
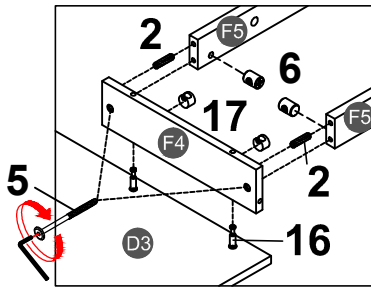

2	
2PCS	
5	
3PCS	
6	
3PCS	
17	
2PCS	

STEP 31:

ÉTAPE

17



8PCS

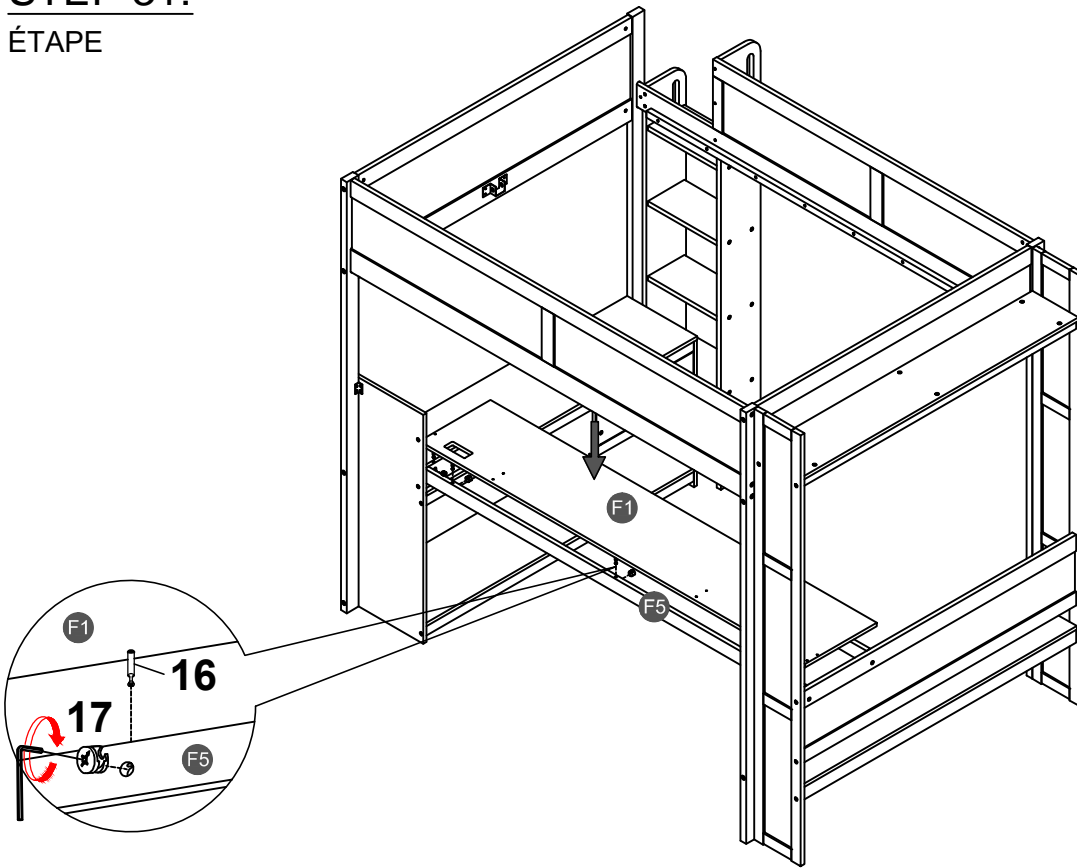

STEP 32:

ÉTAPE

16

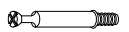

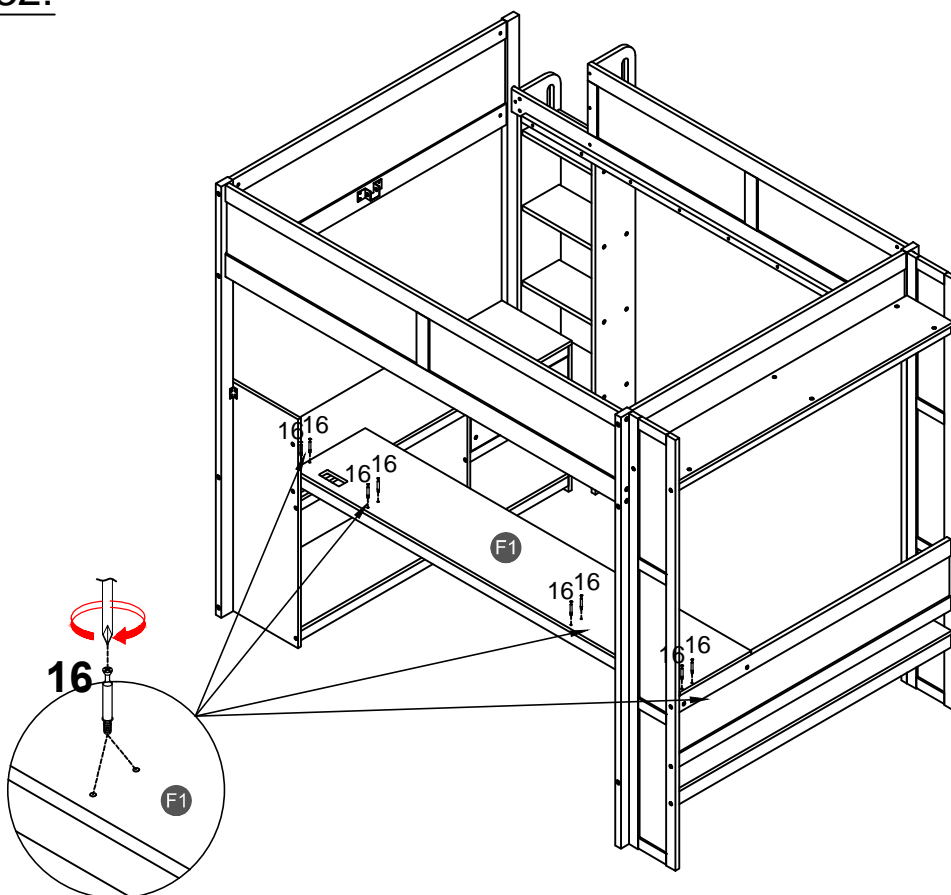

8PCS



STEP 33:

ÉTAPE

5 	6 
1PC	1PC
17 	
8PCS	

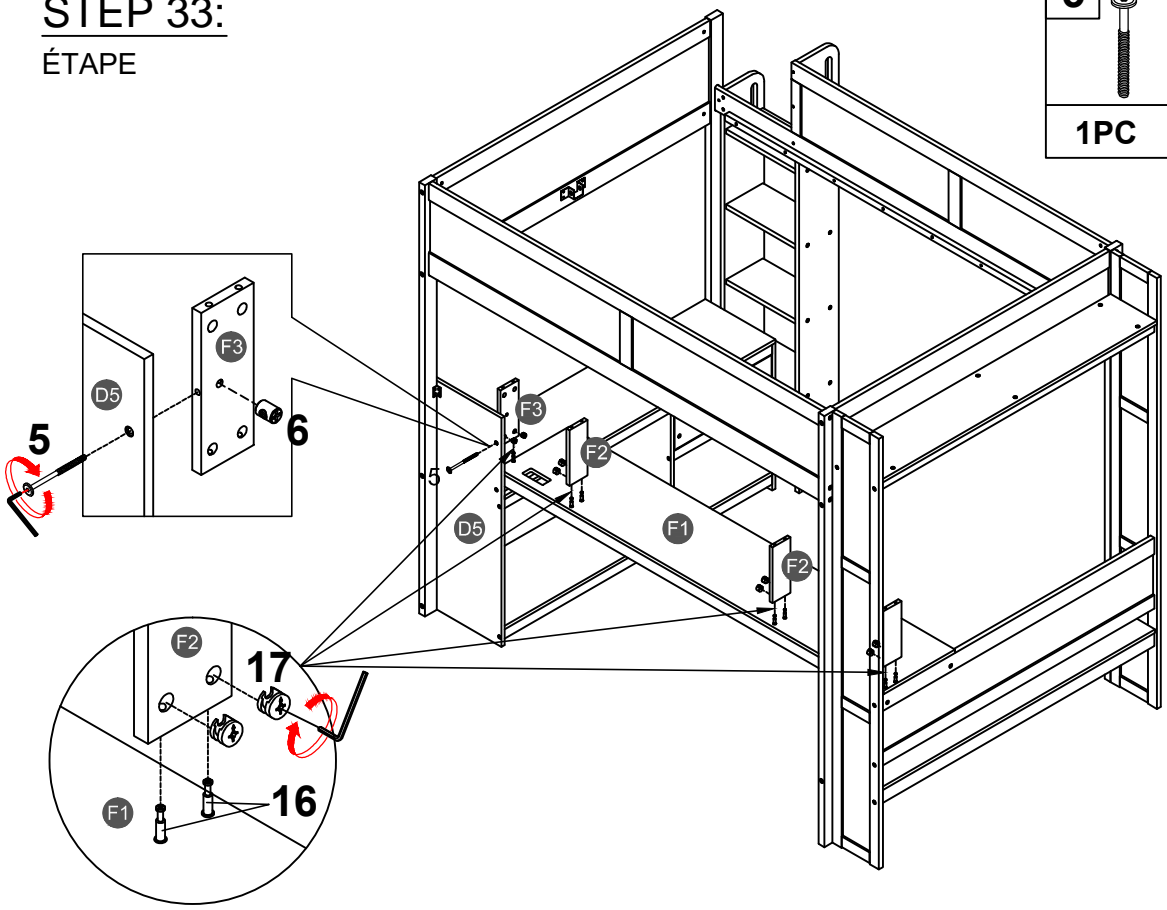

STEP 34:

ÉTAPE

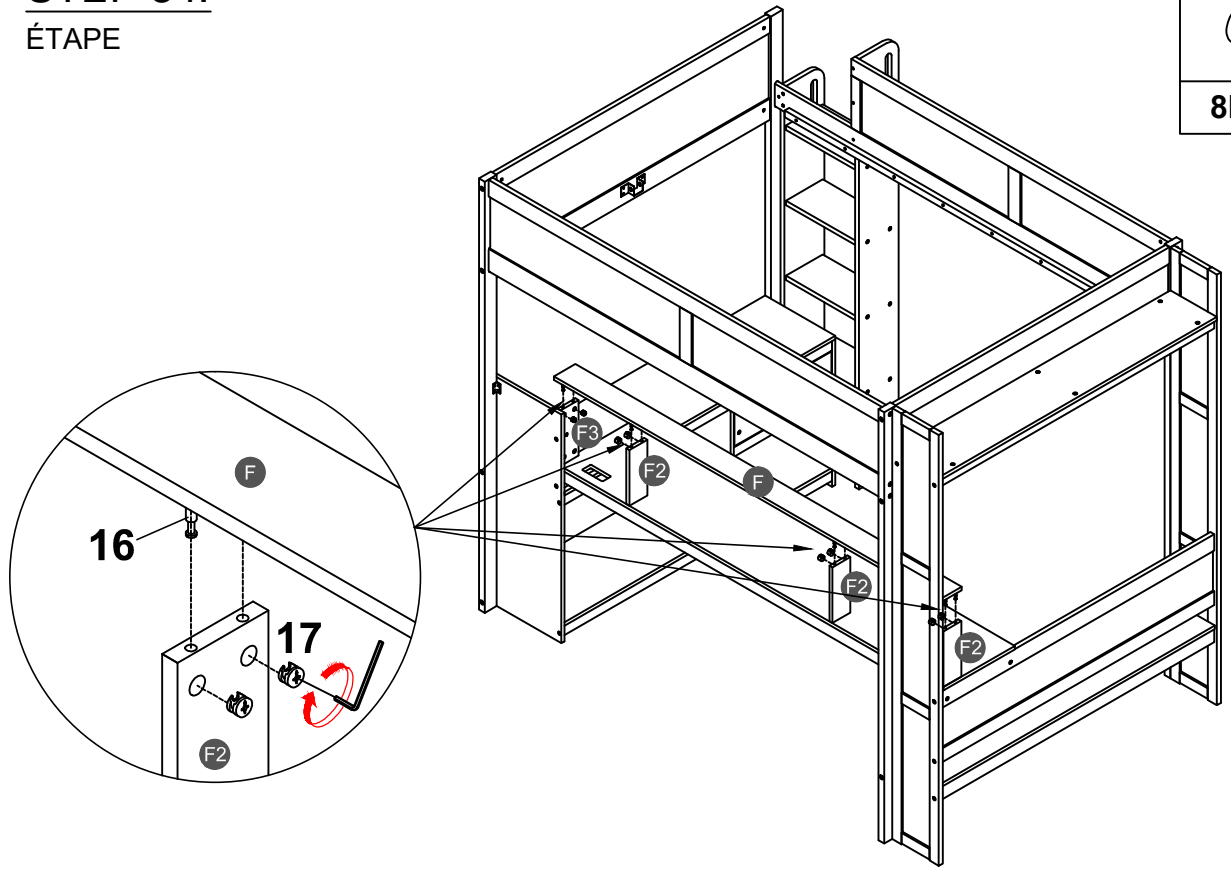

17 
8PCS

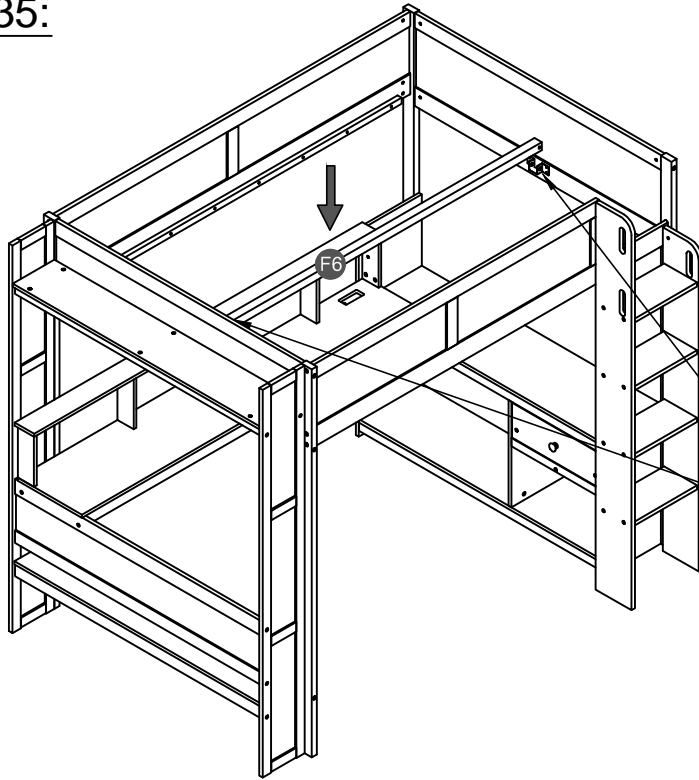

STEP 35:

ÉTAPE



25		26	
2PCS		2PCS	

STEP 36:

ÉTAPE

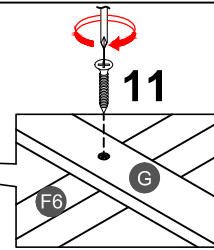
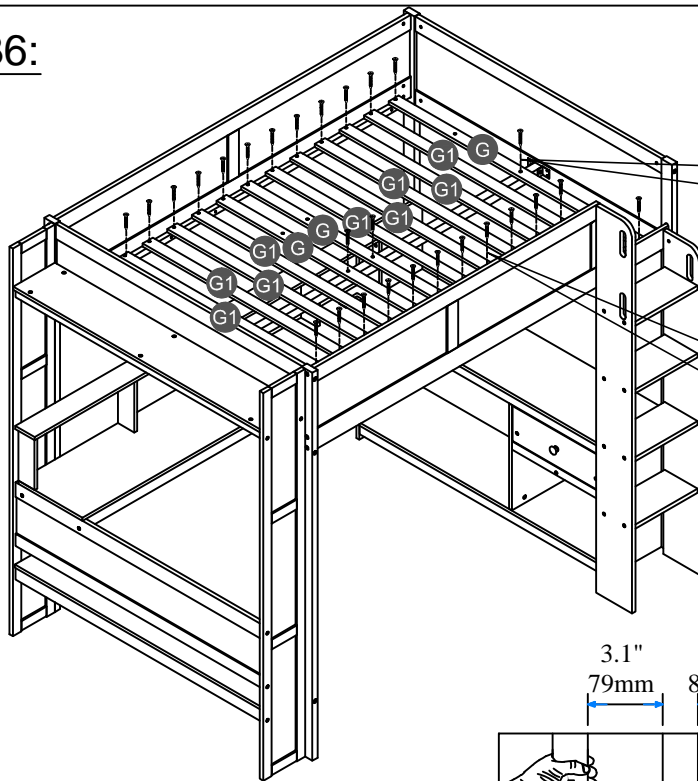



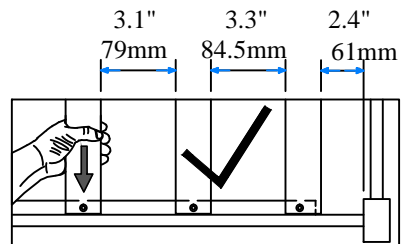
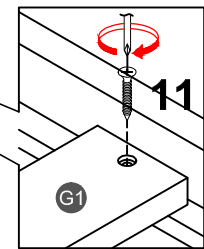

9	
32PCS	



NOTE: Please make sure the bed slats close to the side rail before locking the screws to avoid breakage. This step is required for both the left and right sides. Moreover, please do not lock the screws of the bed slats at the outermost edge to avoid damaging.

Remarque: Assurez-vous Les lattes du lit fermer du rail latéral avant de verrouiller les vis pour éviter la casse. Cette étape est requise pour tous les deux côtés gauche et droit. De plus, ne verrouillez pas les vis des lattes de lit sur le bord le plus extérieur pour éviter d'endommager.

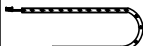
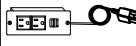
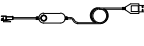
STEP 37:
ÉTAPE

10 	11 	19 	20 	21 	22 	23 
18PCS	1PC	1PC	1PC	1PC	1PC	1PC

28 
4PCS

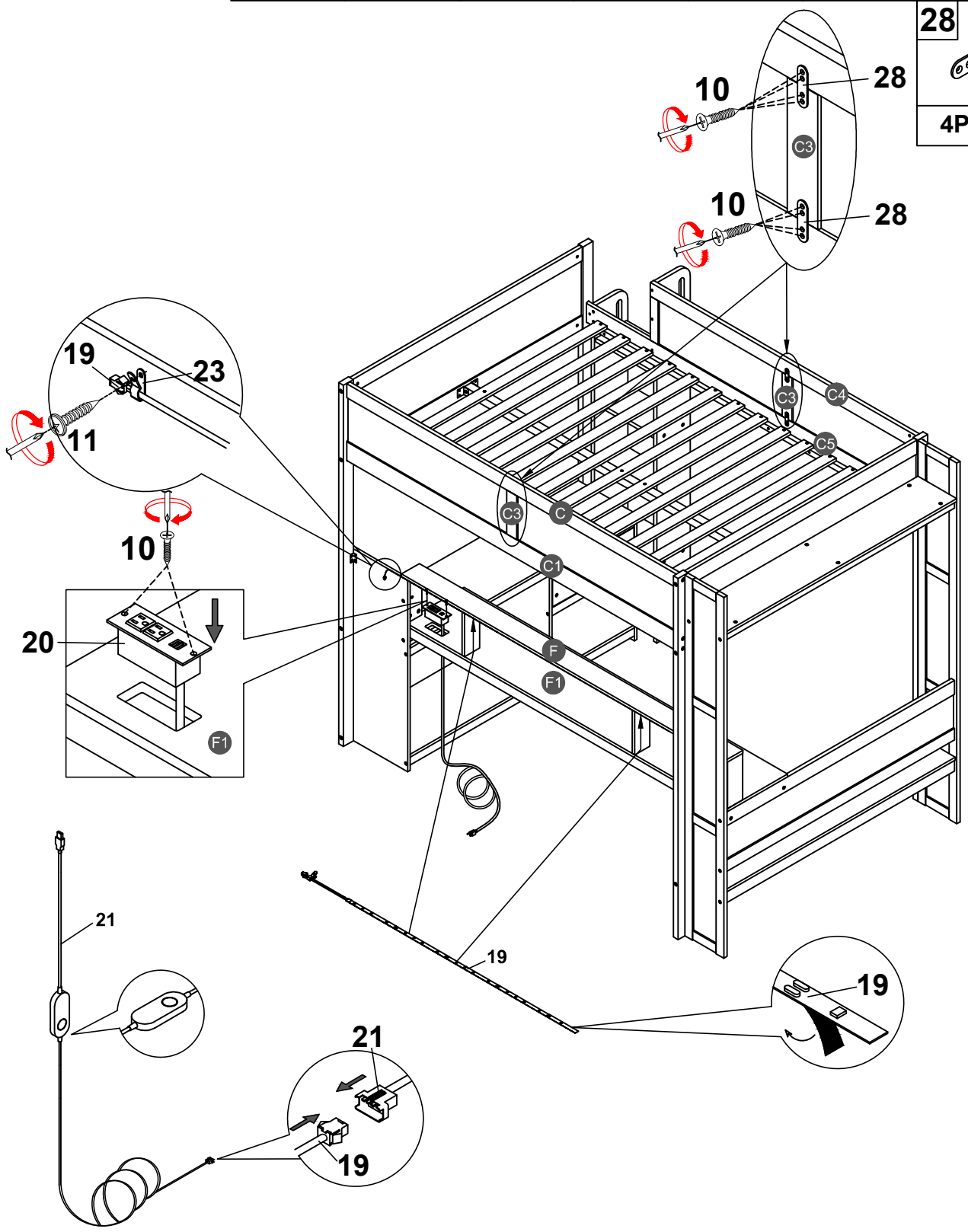

Make sure to tighten all the screws of the bed.

Assurez-vous de serrer toutes les vis des de lit.