

ASSEMBLY INSTRUCTIONS

ARK PRO L SHAPE

带置物架皮面三抽升降桌

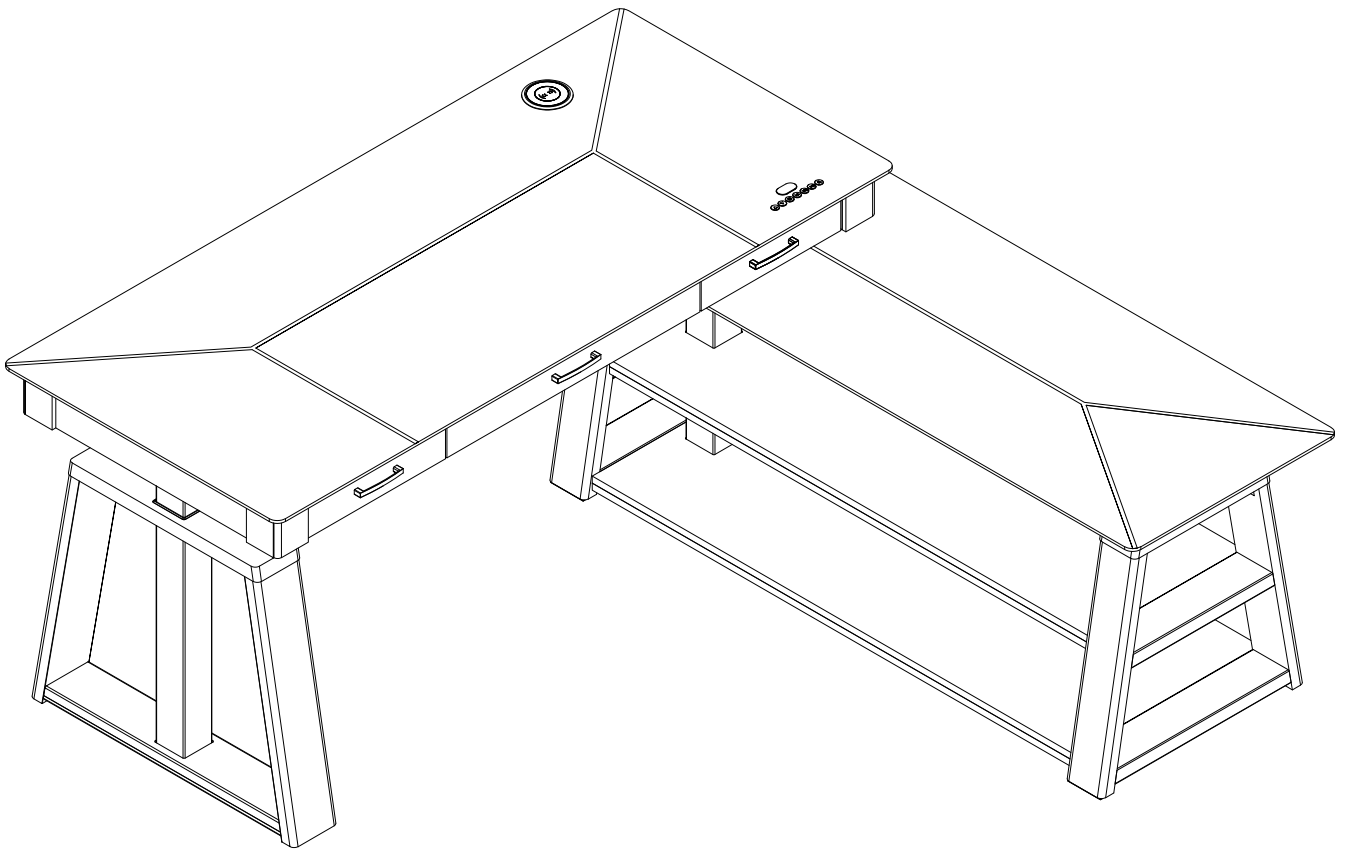

If you need to return the goods, please keep all the packaging materials and return it in the original packaging!

Si vous devez retourner la marchandise, veuillez conserver tous les matériaux d'emballage et le retourner dans l'emballage d'origine!

Si necesita devolver los productos, conserve todos los materiales de embalaje y devuélvalos en el embalaje original!

如需退货请保留好所有包装材料，并按原包装包好退回!

PARTS / PIÈCES / PARTES / 部件清单

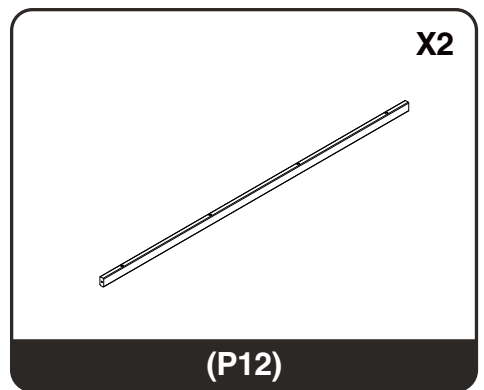
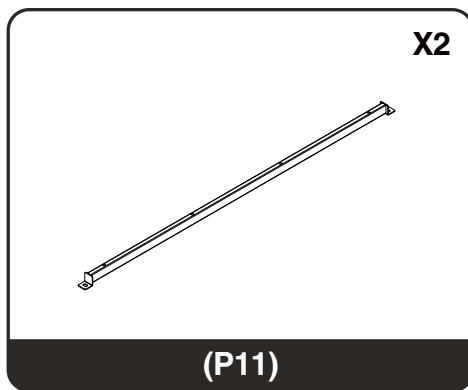
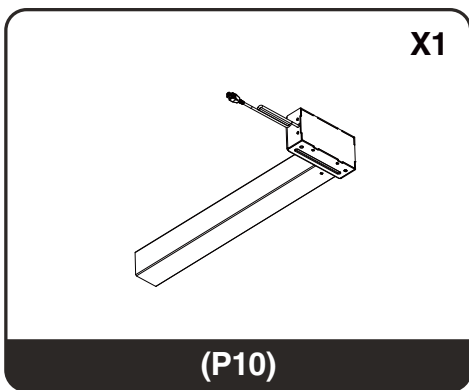
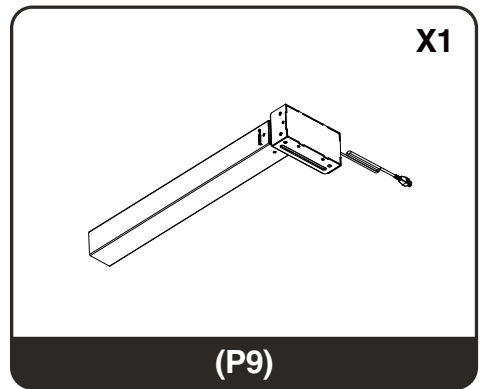
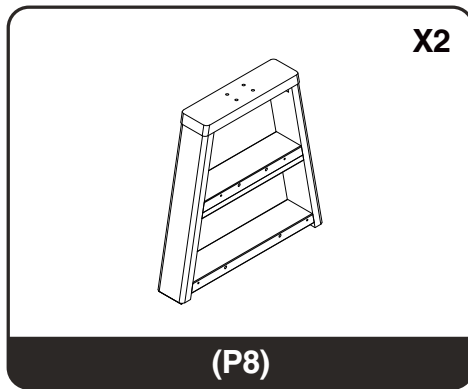
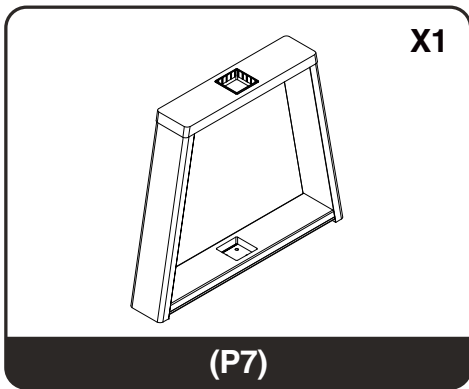
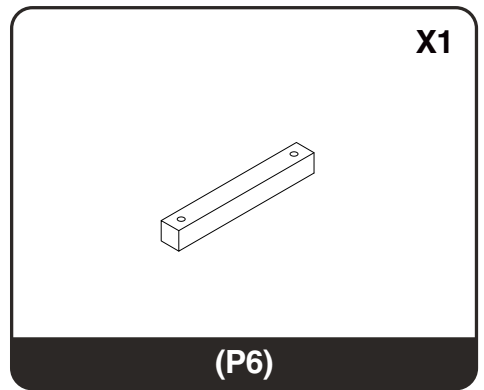
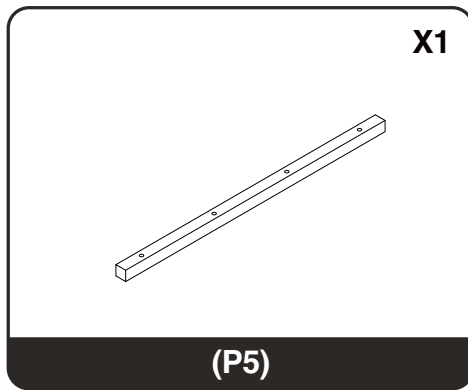
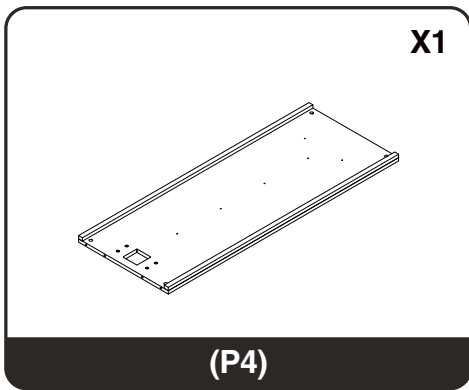
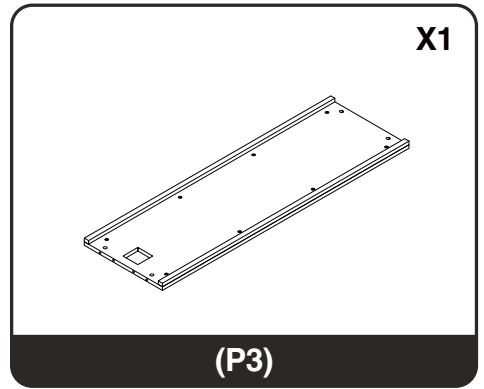
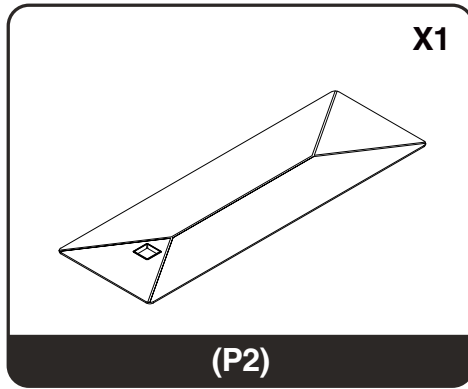
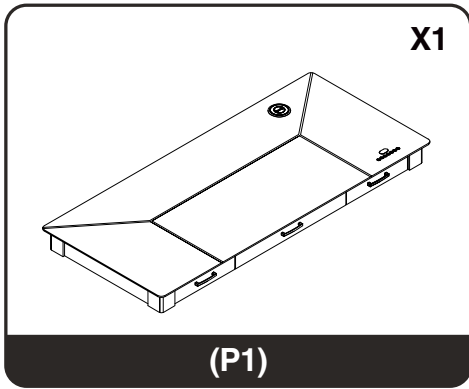

PARTS / PIÈCES / PARTES / 部件清单

X1

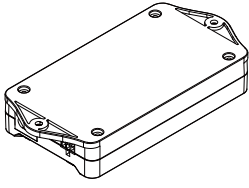

(P13)

X2

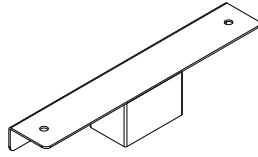

(P14)

X1

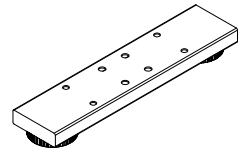

(P15)

X4

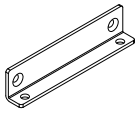

(P16)

X1

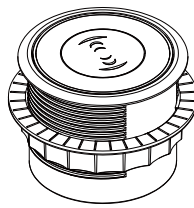

(P17)

X1

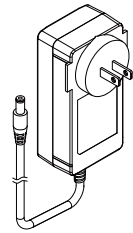

(P18)

X1

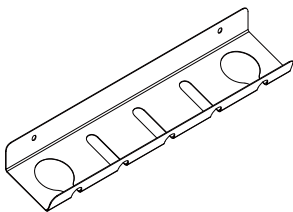

(P19)

X3

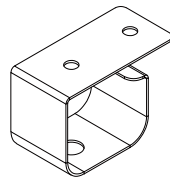

(P20)

X1

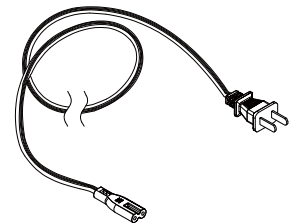

(P21)

HARDWARE / MATÉRIEL / HARDWARE / 配件清单

M8*16mm X8+1

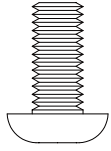

(A)

M8*14mm X8+1

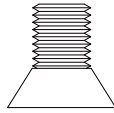

(B)

1/4"*12mm X14+2

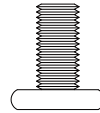

(C)

1/4"*30mm X4+1

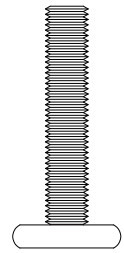

(D)

1/4"*40mm X16+2

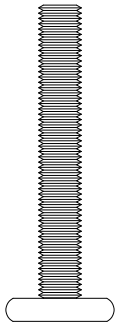

(E)

1/4"*25mm X8+1

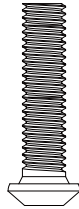

(F)

M6*32mm X6+1

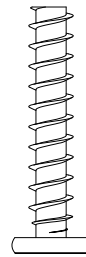

(G)

M8*40mm X8+1

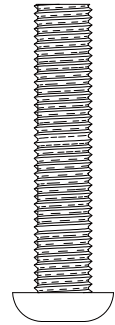

(H)

Ø8*30mm X8+1

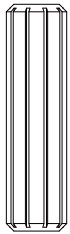

(I)

Ø6.5*35mm X8+1



(J)

Ø15*12mm X8+1



(K)

85*25*5mm X4



(L)

#6*1/2 X4+1

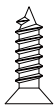

(M)

X4

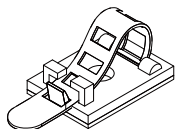

(N)

X1

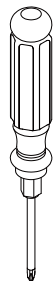

(O)

K4 X1

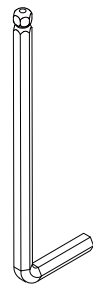

(P)

HARDWARE / MATÉRIEL / HARDWARE / 配件清单

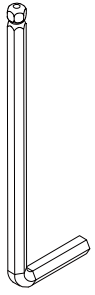

K5 X1

(Q)

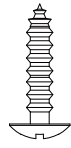

#6*5/8 X2+1

(R)

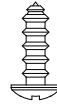

#6*1/2 X6+1

(S)



Do not tighten the screws until all of them are screwed into the holes.

Ne serrez pas les vis avant qu'elles ne soient toutes vissées dans les trous.

No apriete los tornillos hasta que todos estén atornillados en los agujeros.

安装时先不要把螺丝拧紧，等所有螺丝都拧到螺纹孔上再将全部螺丝拧紧。

ASSEMBLY INSTRUCTIONS

INSTRUCTIONS DE MONTAGE

INSTRUCCIONES DE MONTAJE

安装步骤

STEP 1

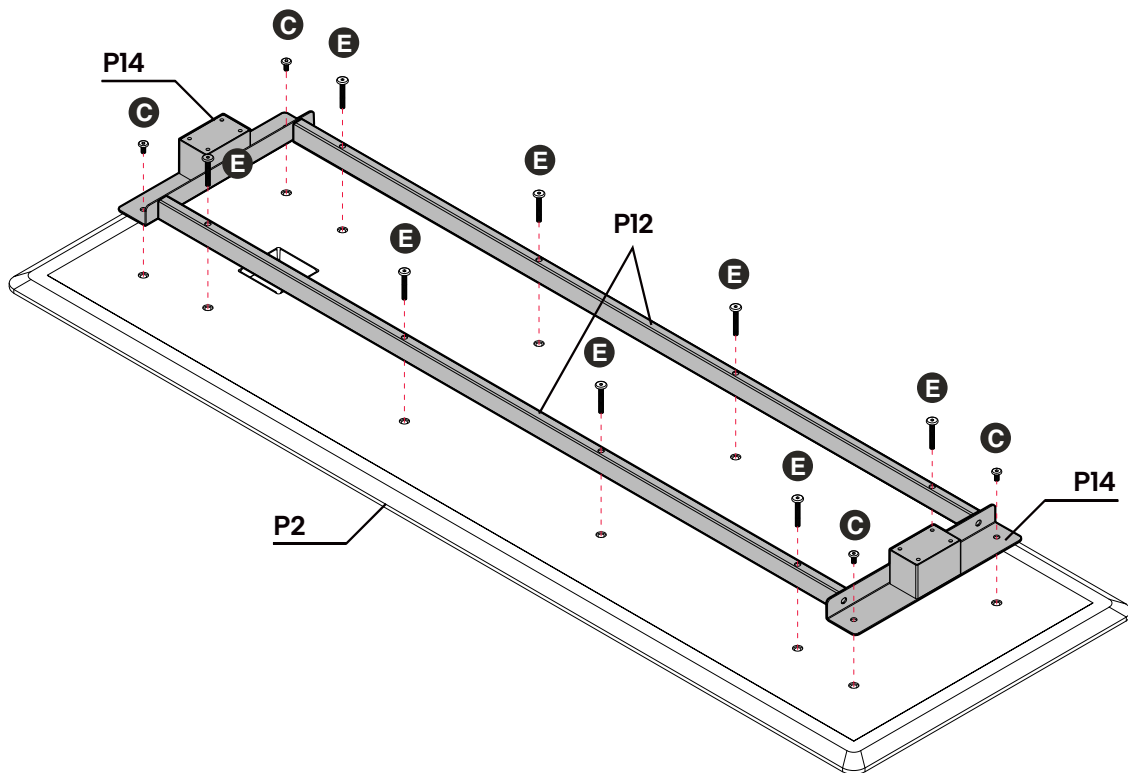
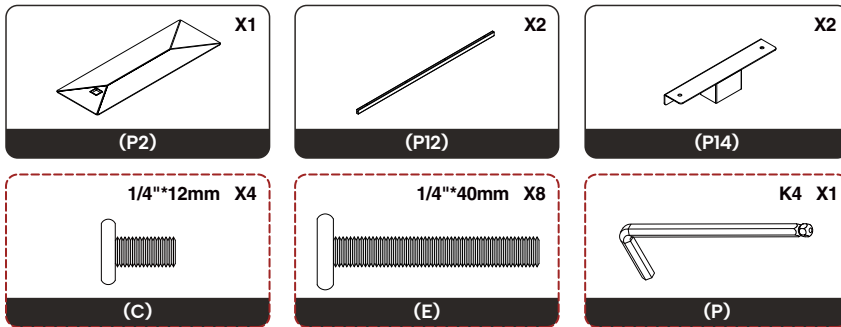

STEP 2

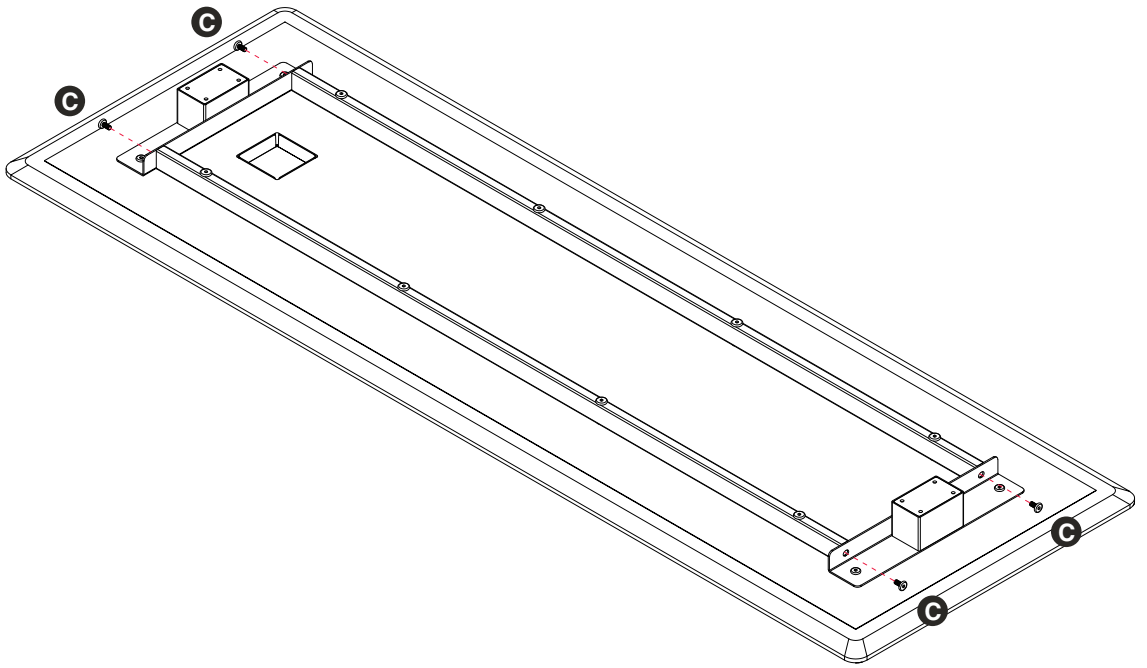
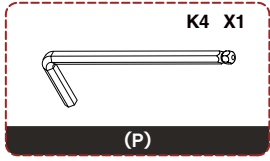
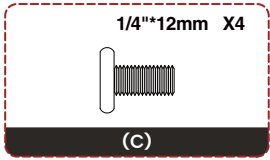

STEP 3

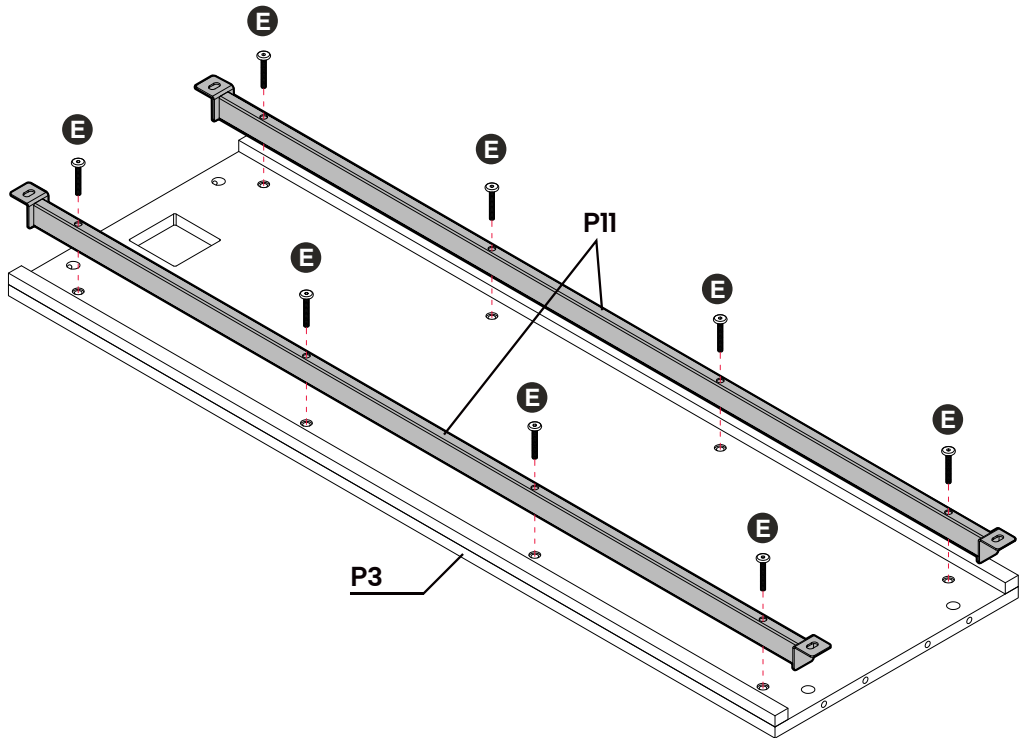
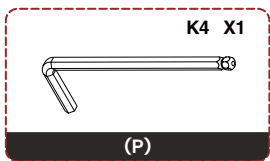
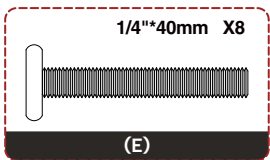
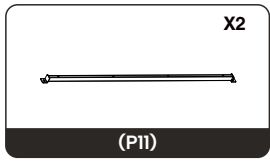
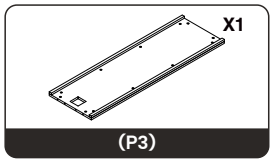

STEP 4

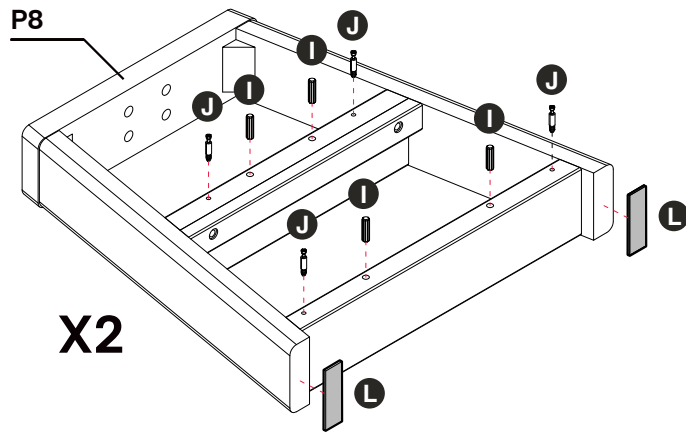
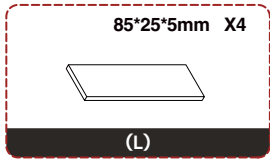
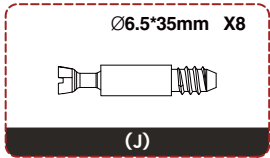
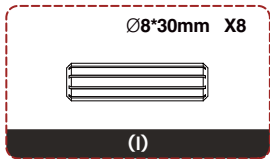
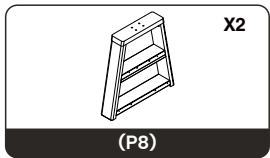

STEP 5

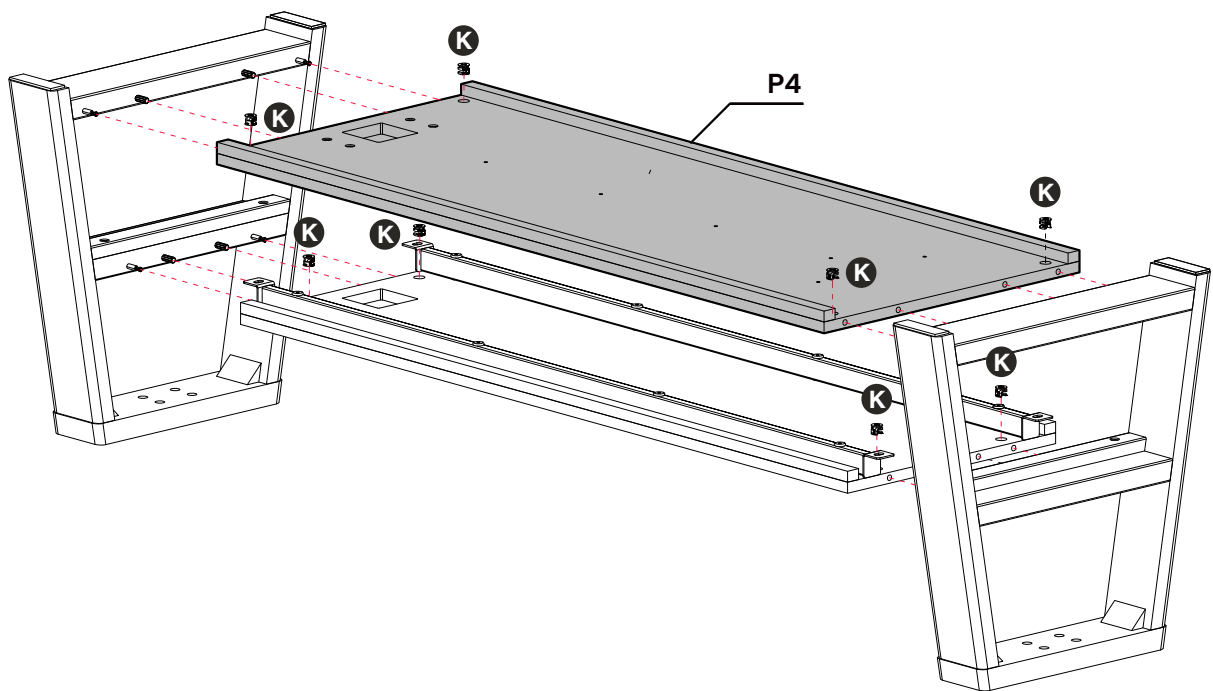
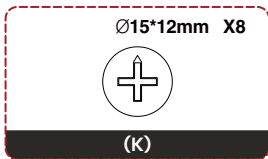
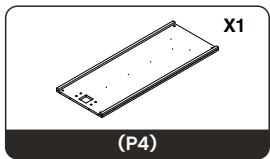

STEP 6

1/4"×12mm X4



(C)

K4 X1



(P)

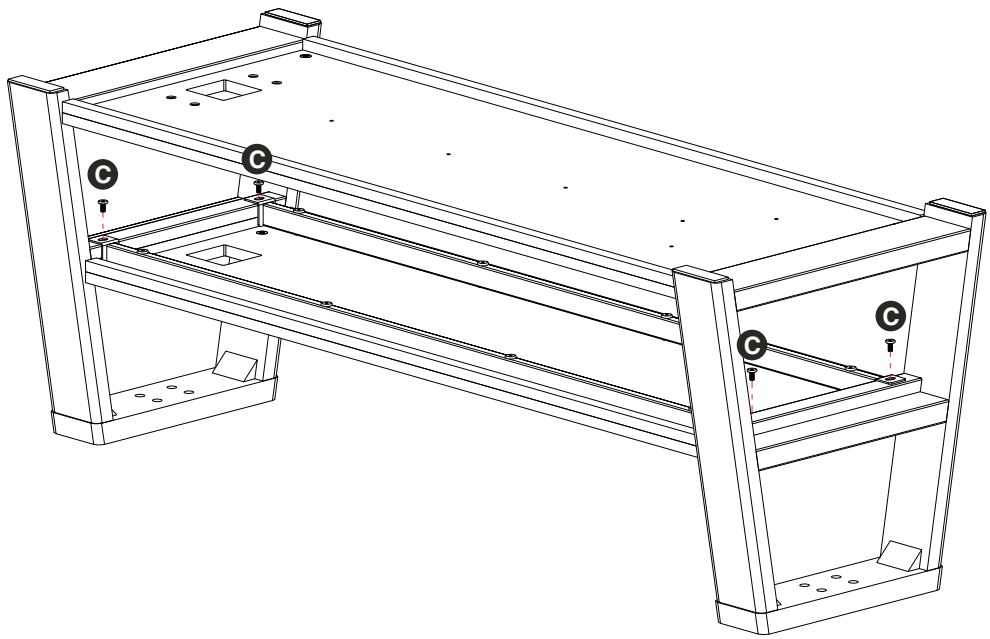

STEP 7

1/4"×25mm X8



(F)

K4 X1



(P)

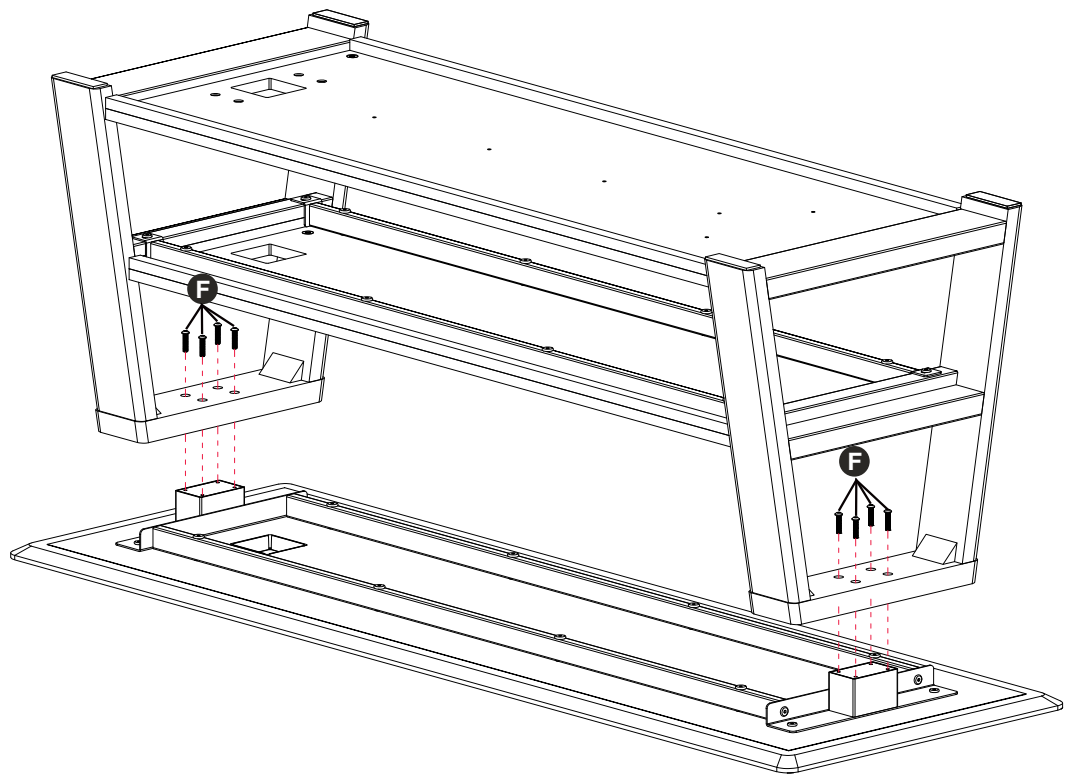

STEP 8

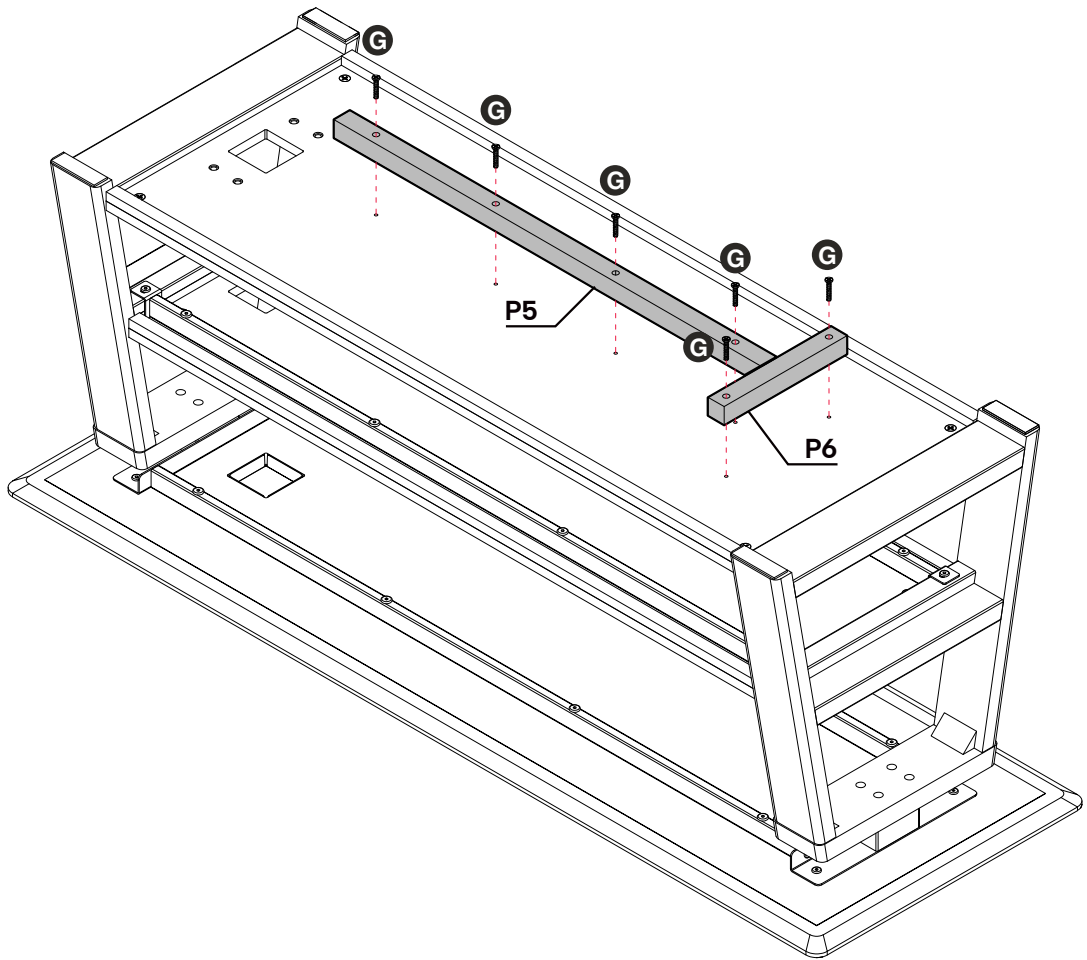
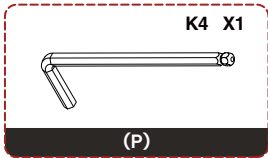
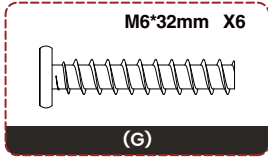
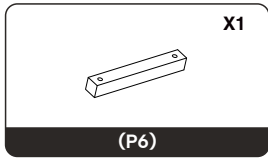
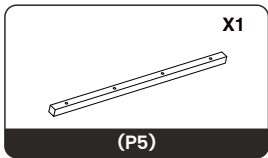

STEP 9

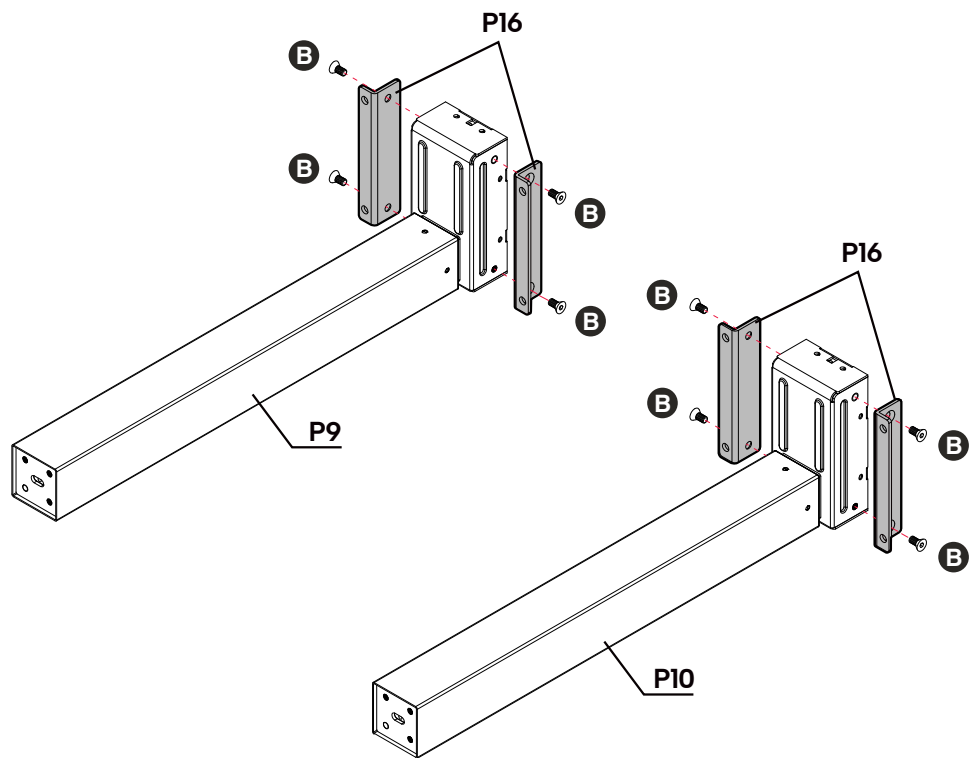
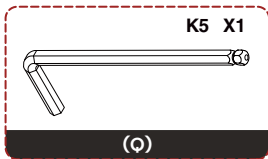
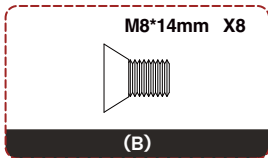
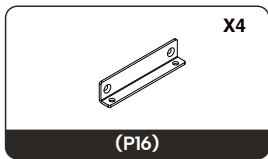
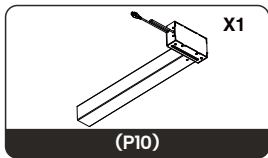
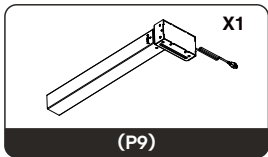

STEP 10

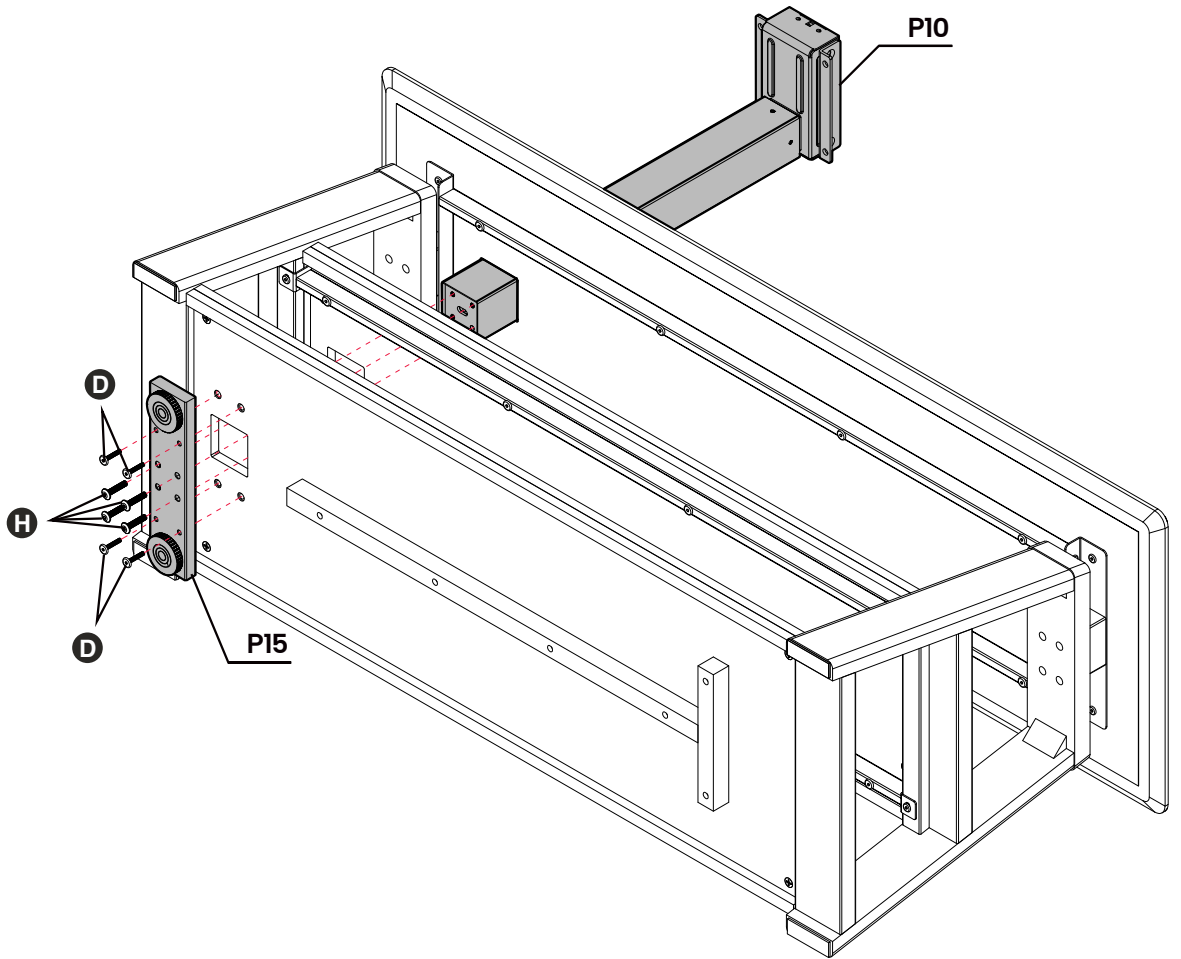
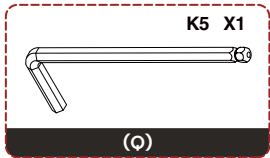
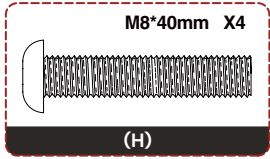
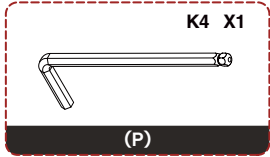
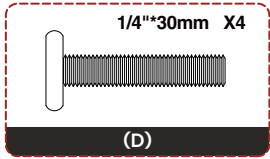
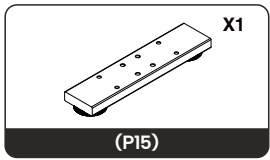

STEP 11

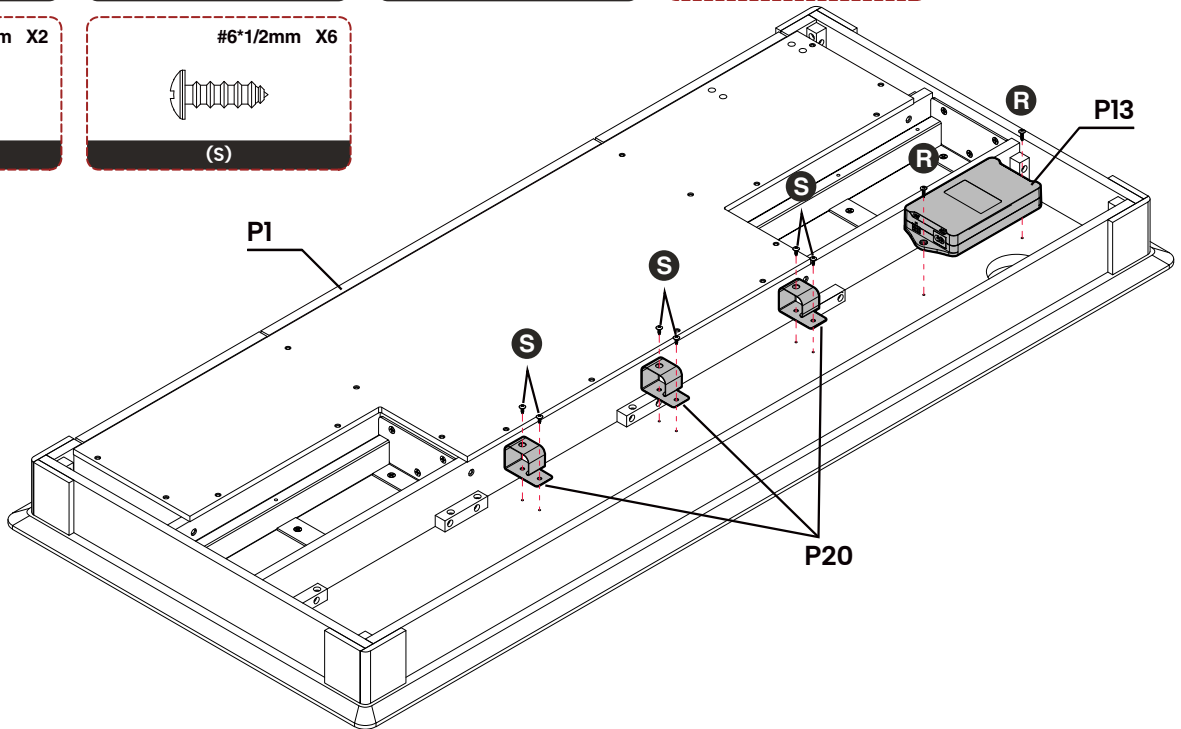
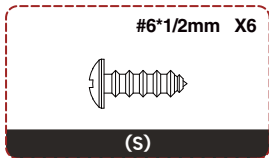
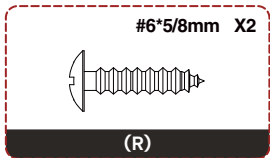
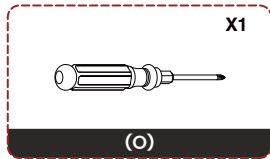
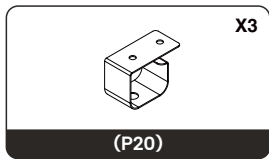
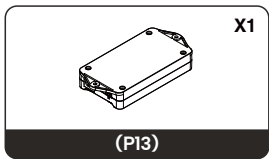
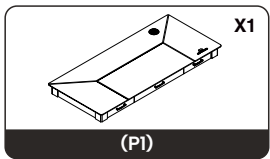

STEP 12

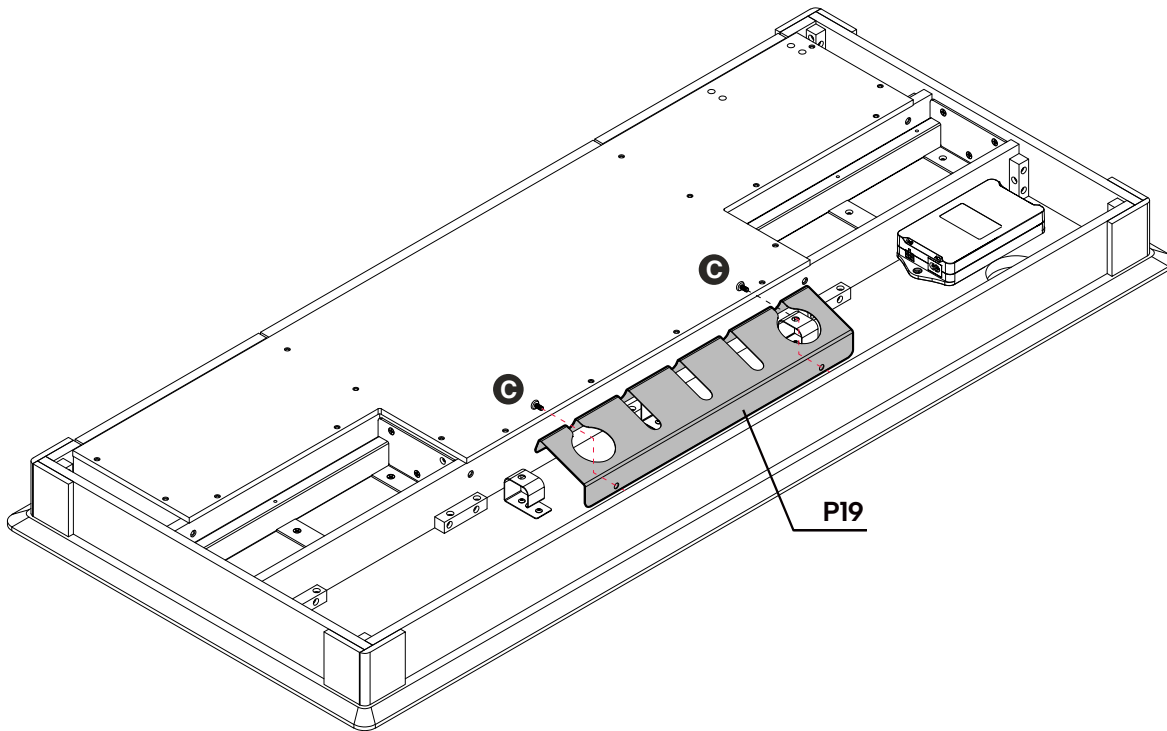
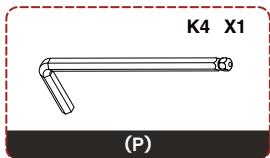
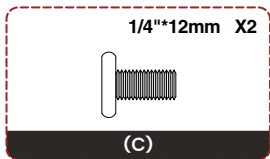
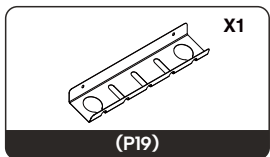

STEP 13

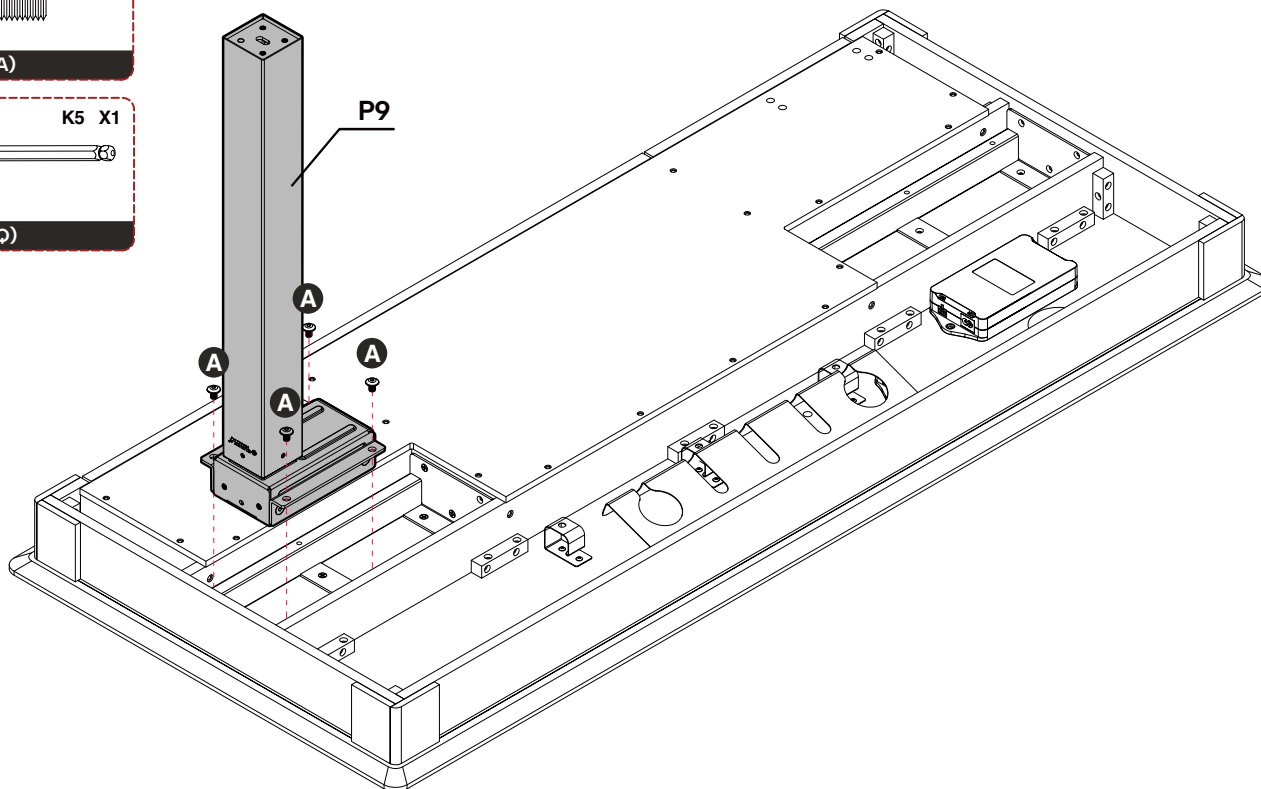
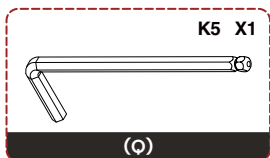
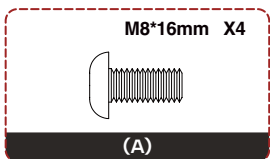

STEP 14

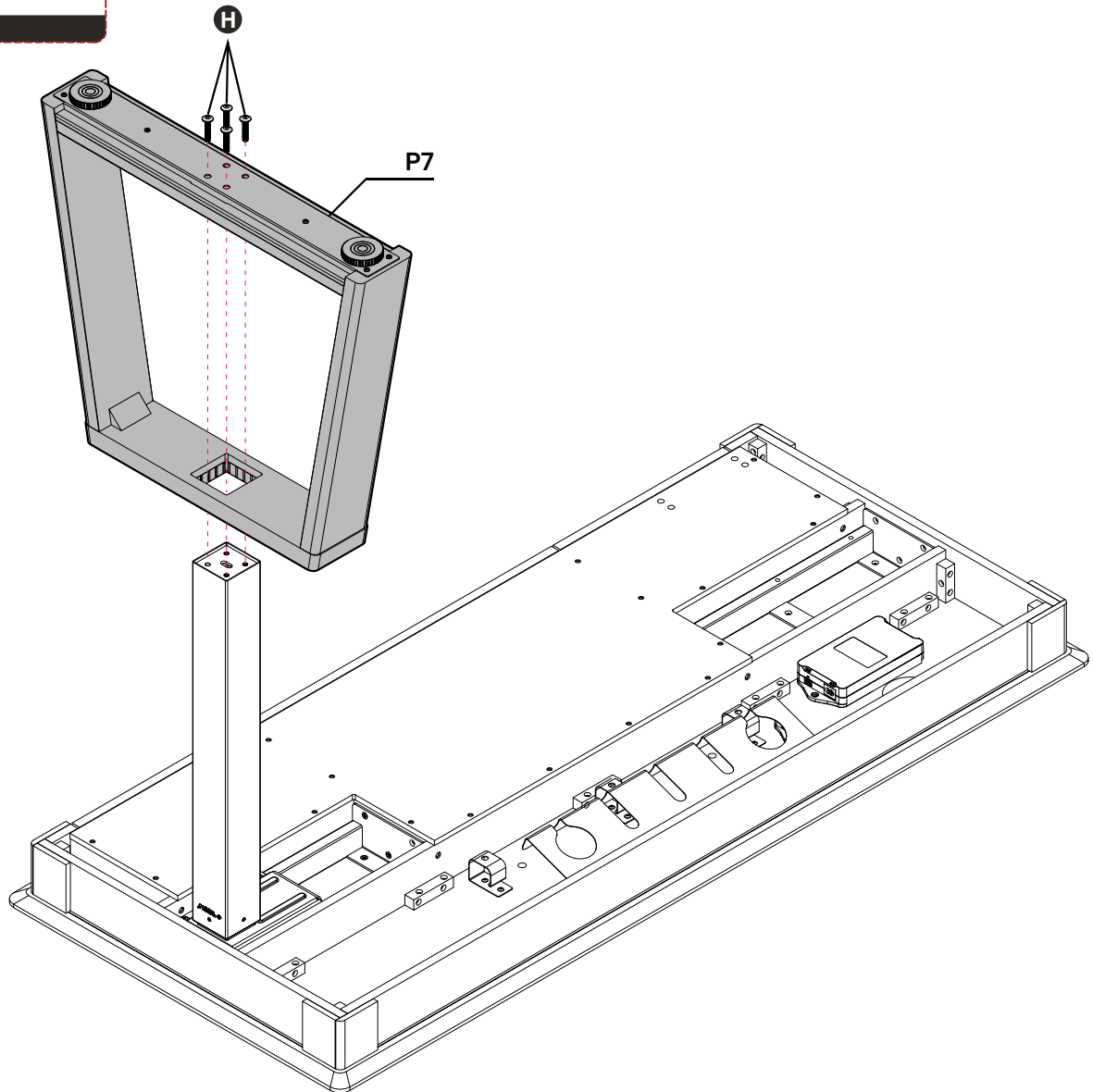
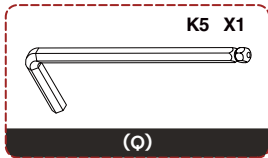
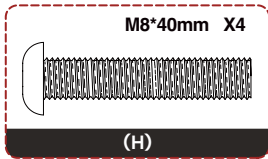
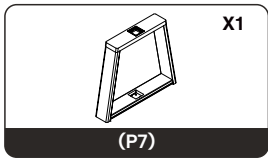

STEP 15

Note: 1. Turn over the large table top over. 2. Align the table top with the lifting leg on the sub-table. 3. Lower slowly. 4. Lift the main panel and move it left and right to align with the screw holes.

Note: 1. retourner le grand plateau de table. 2. Aligner le plateau de la table avec le pied de levage de la table secondaire. 3. Abaisser lentement. 4. Soulever le panneau principal et le déplacer de gauche à droite pour l'aligner sur les trous de vis.

Nota: 1. Dé la vuelta al tablero grande. 2. Alinee el tablero de la mesa con la pata de elevación de la submesa. 3. Baje lentamente. 4. Levante el tablero principal y muévalo a izquierda y derecha para alinearlos con los orificios de los tornillos.

注意: 1.将大台面翻转。 2.将台面对准副台上升降腿。 3.缓慢放下。 4.抬起主面板左右挪动对准螺丝孔位。

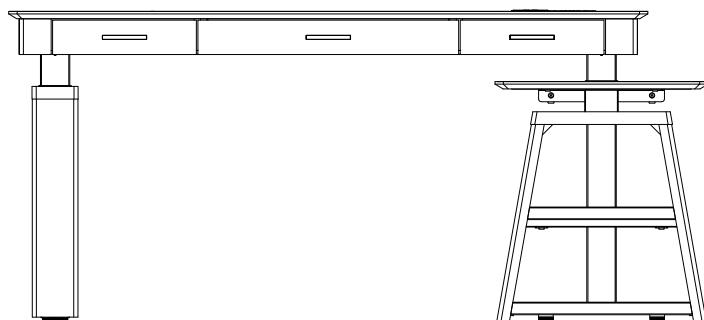
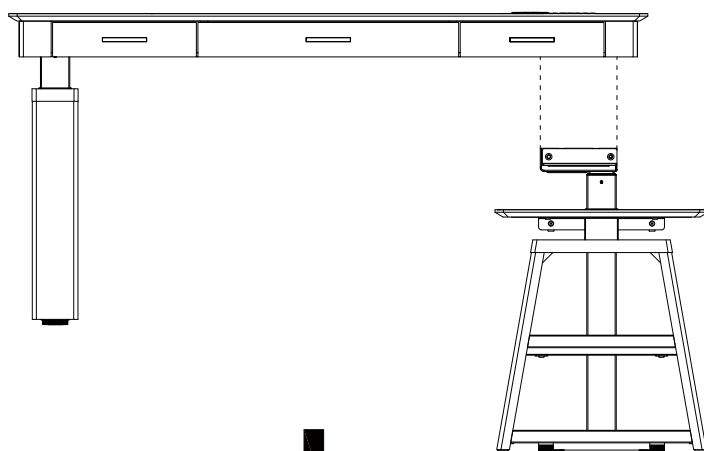
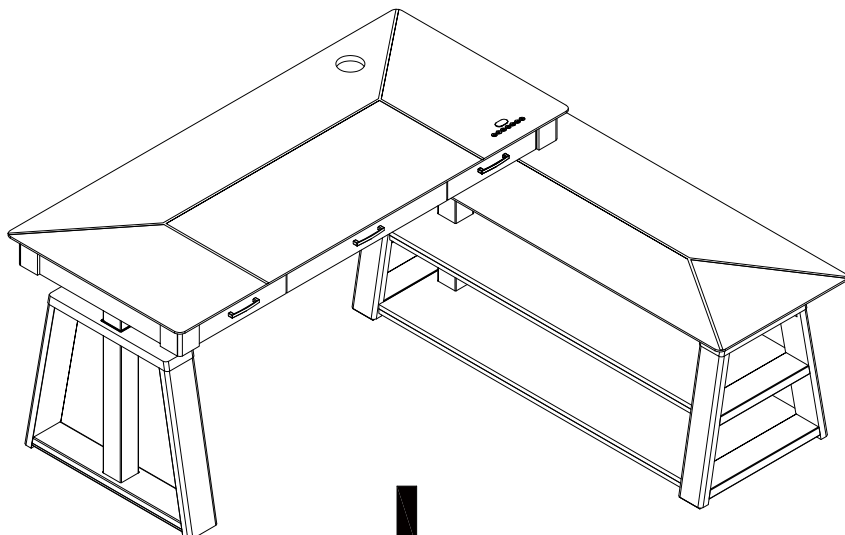

Note: This step requires two or more people to install.

Note: Cette étape nécessite au moins deux personnes pour l'installation.

Nota: Este paso requiere dos o más personas para instalar.

注意: 此步骤需要两人以上配合安装。

STEP 16

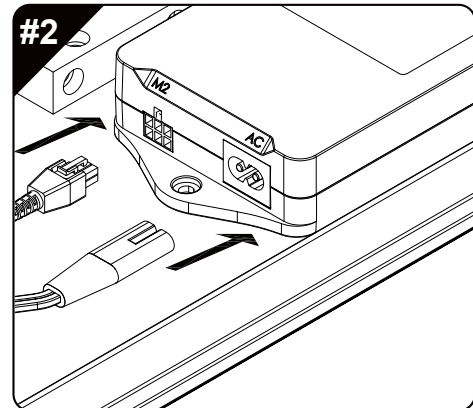
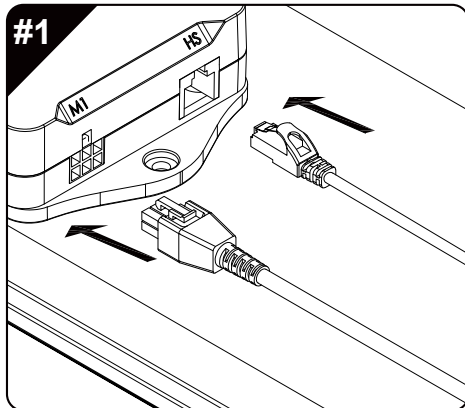
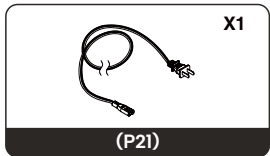
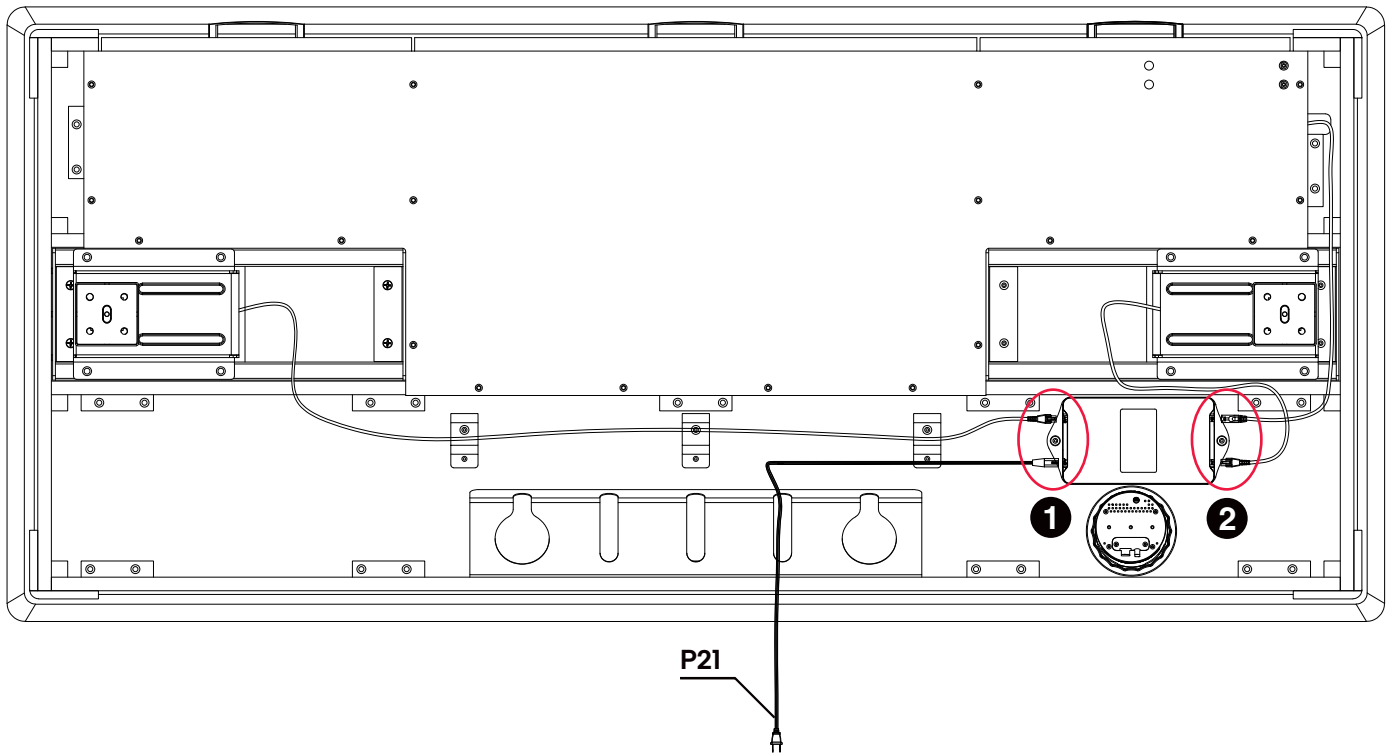
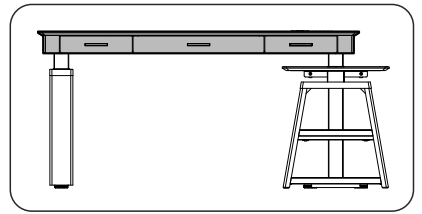
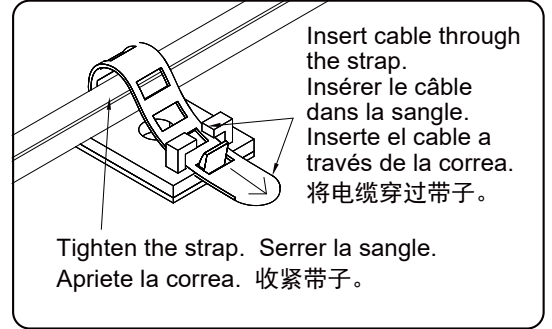
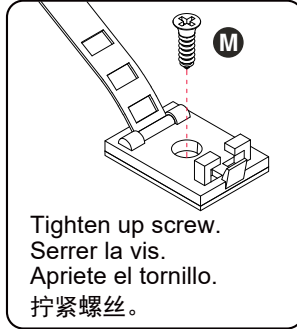
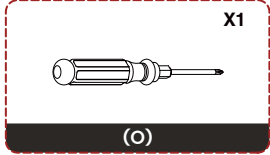
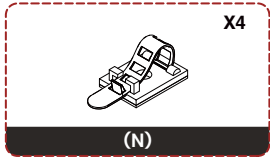
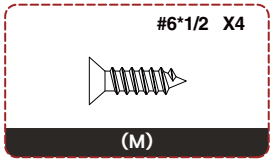

STEP 17

Note: 1. After the stand is placed and stabilized, one person holds the large table top;
2. Press the rise button to the appropriate height to lock the screws.

Note: 1. une fois le support placé et stabilisé, une personne tient le grand plateau de la table ;
2. Appuyer sur le bouton d'élévation jusqu'à la hauteur appropriée pour bloquer les vis.

Nota: 1. Una vez colocado y estabilizado el soporte, una persona sujeta el tablero de la mesa grande;
2. Pulse el botón de elevación hasta la altura adecuada para bloquear los tornillos.

注意: 1. 放置稳定后，一人扶住大台面；
2. 按下上升键到合适的高度锁紧螺丝。

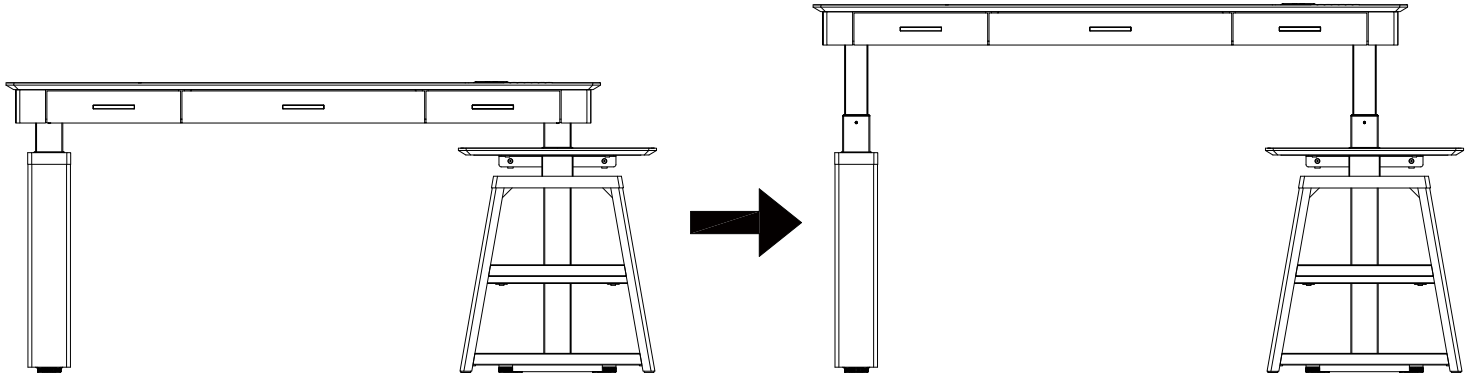

STEP 18

Note: This step requires two or more people to install.

Note: Cette étape nécessite au moins deux personnes pour l'installation.

Nota: Nota: Este paso requiere dos o más personas para instalar.

注意: 此步骤需要两人以上配合安装。

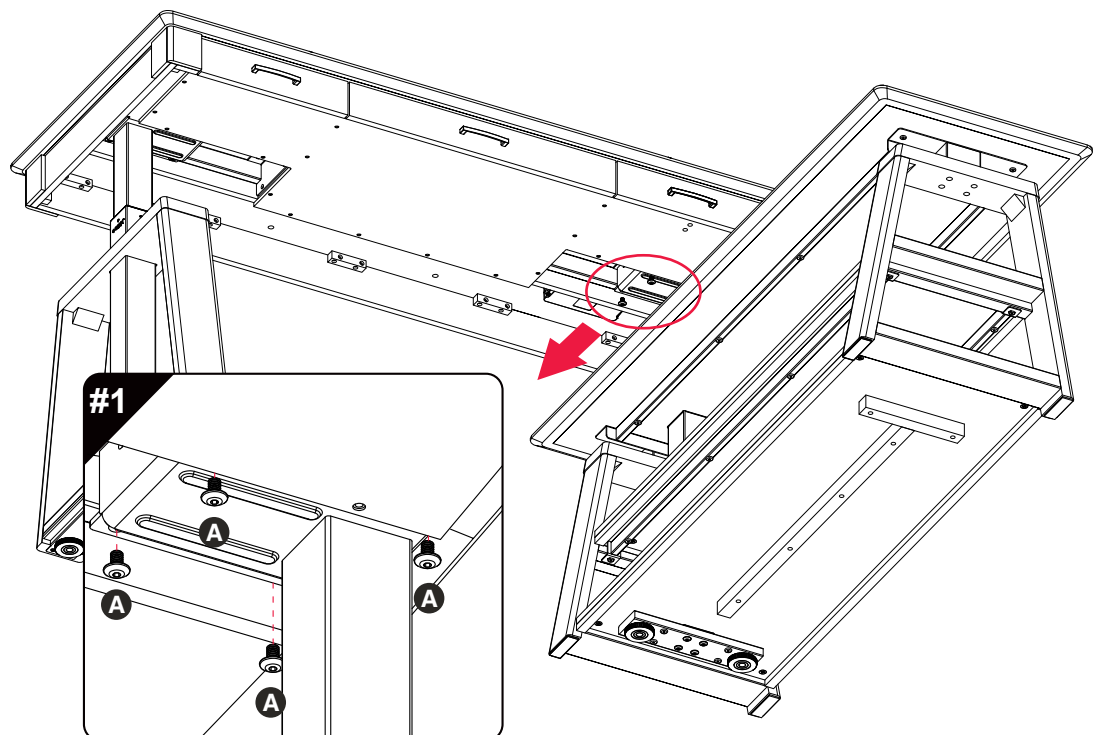
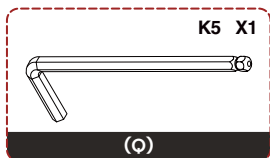
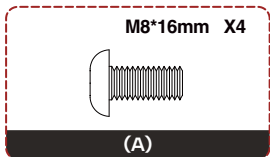

STEP 19

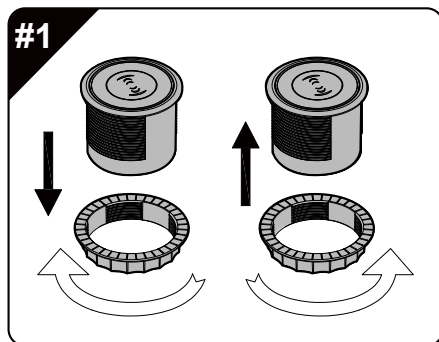
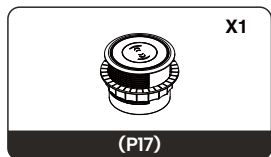

Wireless Charger
5W / 7.5W / 10W

Wireless charger comes with USB plug.
El cargador inalámbrico viene con enchufe USB.
Le chargeur sans fil est livré avec une prise USB.
无线充自带USB插头。

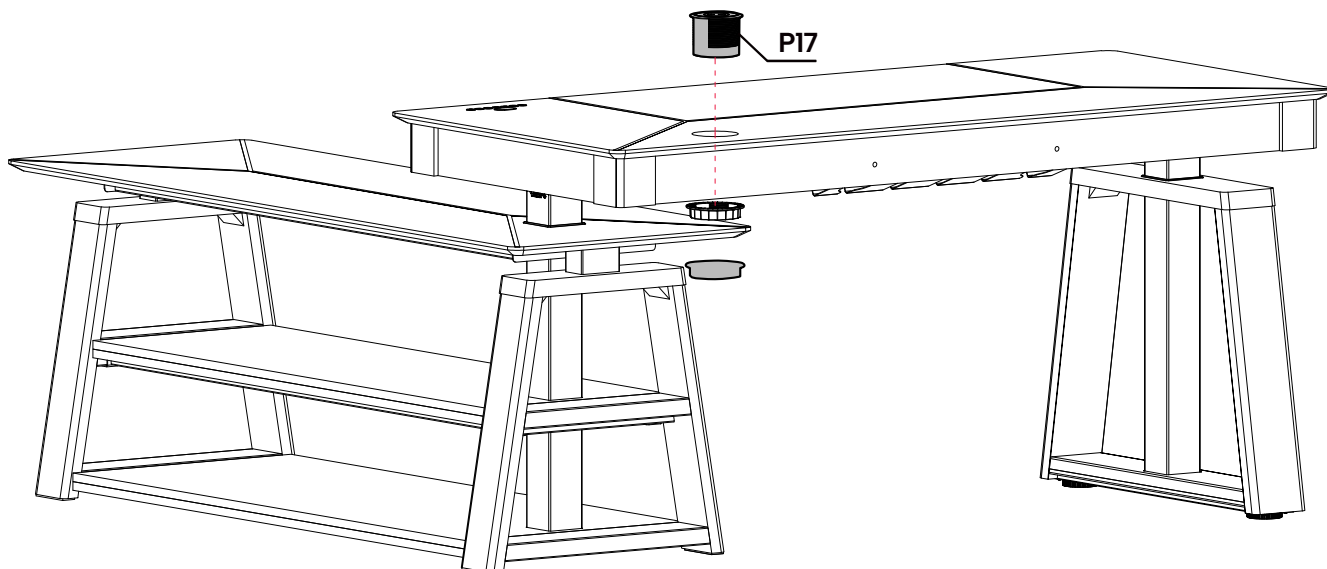

STEP 20

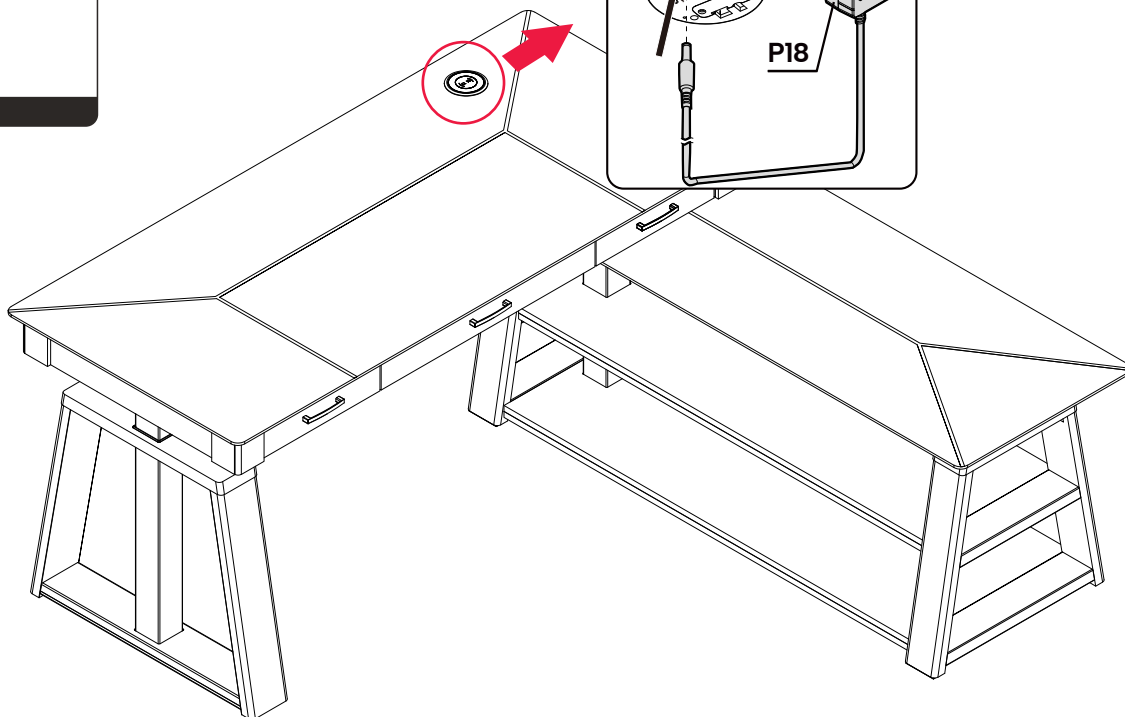
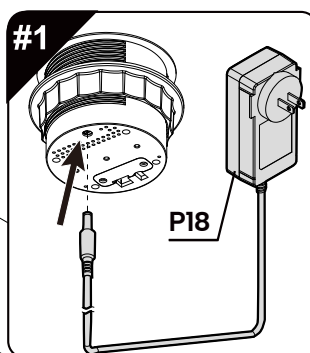
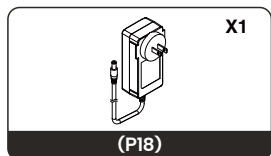

STEP 21

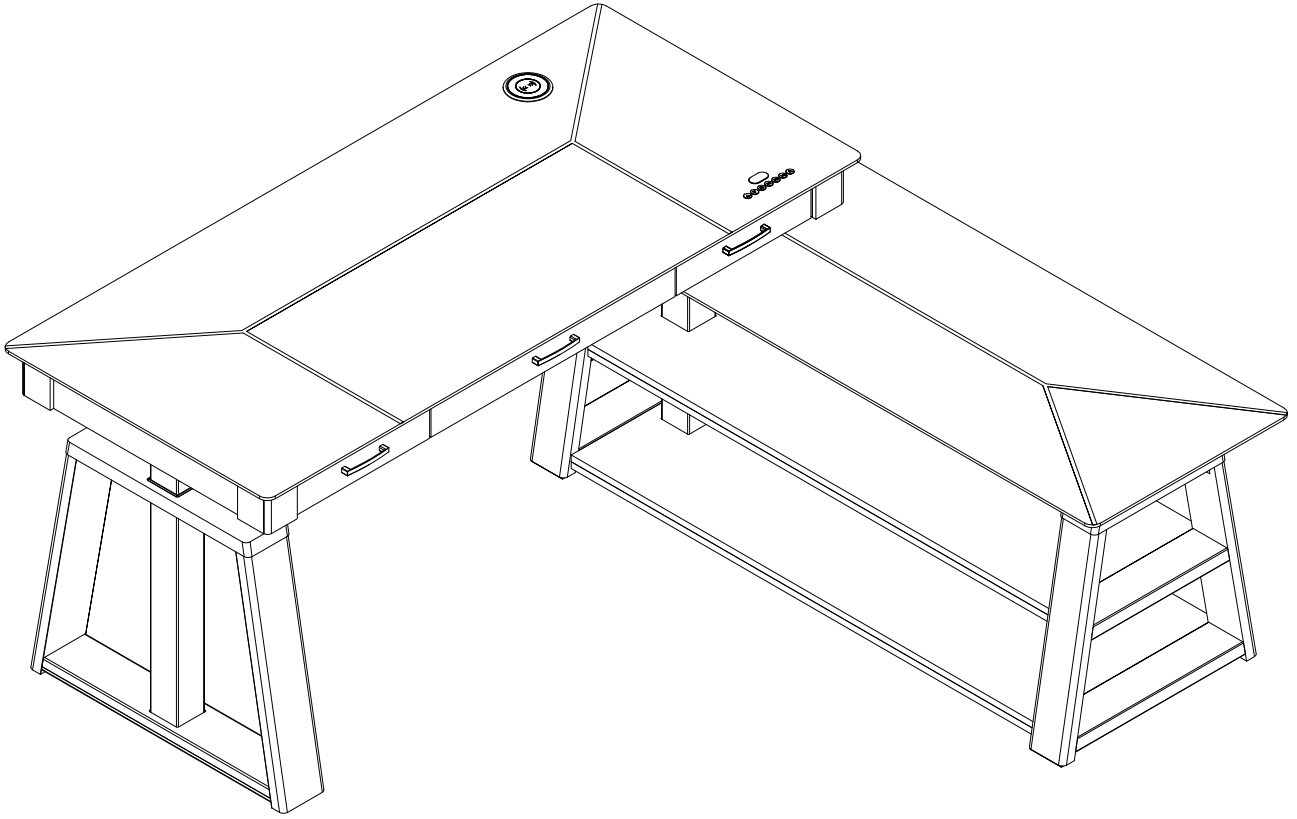

OPERATING INSTRUCTIONS

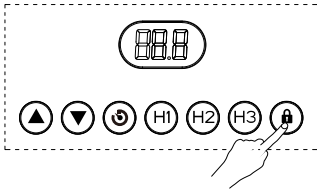

LOCK AND UNLOCK

Lock: Press and hold the "  " key for 5 seconds. When the digital tube displays "Loc", it means that the system has been locked and the system cannot be raised or lowered.

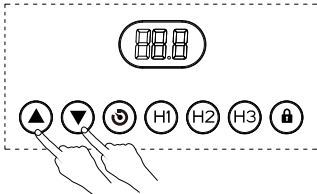

Unlock: Press and hold the "  " key for 5 seconds. When the digital display changes from "Loc" to normal digital display, it means the system has been unlocked.



UP AND DOWN KEY OPERATION



When the "  " key is pressed, the desktop runs upward until it reaches the highest point of the desktop.

When the "  " key is pressed, the desktop runs downward until it reaches the lowest point of the desktop.

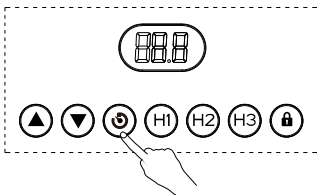
When the "  " or "  " key is clicked, the desktop moves a small distance accordingly to realize jogging.



LOCATION STORAGE AND MEMORY OPERATION

The hand controller in the picture above can store 3 memory points. The storage method is as follows. When running to a specific point, press the "  " button. The digital tube will display "S-" and "  " will flash. At this time, press "H1-H3" key to store the current position to the corresponding label.



In fully automatic mode (S-6 is 1), if you want to run to the memory point, you only need to click the key corresponding to the storage location. At this time, the digital tube will display the height of the corresponding key position, and then automatically run to the location stored.

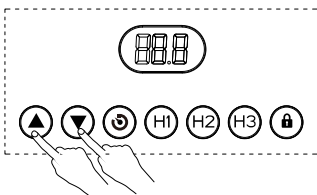

Corresponding to the height, when running, any key can stop the system.

In semi-automatic mode (S-6 is 0), if you want to run to the memory point, you only need to keep pressing the key corresponding to the storage position. At this time, the digital tube will display the height of the corresponding key position, and then automatically run to the stored height. While running, release the button to stop the system.



HIGH AND LOW LIMIT SETTING

The system supports desktop height limit. The operation method is: when you want to set the current height as the desktop limit height, press and hold the "  " and "  " buttons at the corresponding height for 5 seconds. At this time, you will hear a buzzer sound, indicating Restricted location storage successful. When the table is in the upper half of its travel, the upper position is restricted. When the table top is in the lower half of its travel, the lower position is restricted.

Cancel height limit Method 1: Reset the system at this time, and the system height limit will be cancelled. Method 2: Let the desktop run to the limit high or low point. At this time, press and hold the "  " and "  " buttons at the same time for 5 seconds. You will hear a buzzer sound, indicating that the limit position is successfully cancelled.

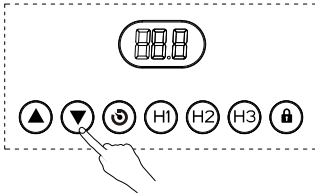

INITIALIZATION OPERATION

When the system is abnormal, or the hand controller displays "RSL", it is necessary to initialize the lifting table. The initialization operation is to press and hold the "▼" button until the motor stops and release the button, and then press "▼" for 5 seconds to enter automatically. Initialization mode. Do not release the "▼" button at this time, if you release the "▼" button, the system stops the initialization mode. After the initialization is completed, the buzzer will sound a prompt, indicating that the initialization is successful.

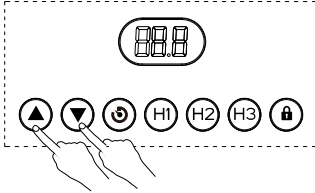

RESET

When the system is replaced with a new table leg, or the parameters need to be restored to the factory settings, press and hold "▲" and "▼" at the same time for 10 seconds to hear a long buzzer prompt, and the parameters are restored to the factory settings. , forced initialization.

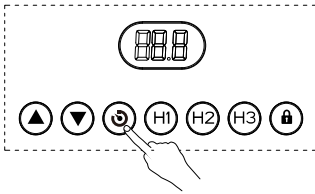

INTERNAL PARAMETERS AND INSTALLATION DISTANCE SETTINGS

By pressing and holding the "⊙" key on the hand controller for 5 seconds, you can enter the setting interface, where "S-x" is displayed and "x" flashes, where "x" is the parameter group. At this time, press "⊙" to enter the parameter group to set the corresponding parameters, and press "▲" or "▼" to switch parameter groups. After setting the parameters, press the "⊙" key to return to the running interface.

The parameters that can be set are as follows:

- "S-1" 0 means metric display, 1 means imperial display.
- "S-2" indicates the sensor's stopping accuracy when encountering obstruction, 0 indicates off, 8 is the most sensitive, and 1 is the least sensitive.
- "S-3" indicates the accuracy of stopping the upward current when encountering resistance, 0 indicates shutdown, 8 is the most sensitive, and 1 is the least sensitive.
- "S-4" indicates the accuracy of stopping the downward current when encountering resistance, 0 indicates shutdown, 8 is the most sensitive, and 1 is the least sensitive.
- "S-5" indicates the installation distance in cm.
- "S-6" 0 means pressing the storage position key to run and then releasing it to stop running, 1 means pressing the storage position key to automatically run to the stored position and any key to stop.
- "S-7" means 0 means turning off the 2-minute and 18-minute working system and relying only on the temperature protection controller, and 1 means turning on the 2-minute and 18-minute working system.
- "S-8" means the left and right tilt of the desktop, sensitivity, to prevent the screw rod from breaking or other causes of inconsistent heights of the two table legs. 0 means off, 1-8 means a tilt angle of 0.5-4° respectively.

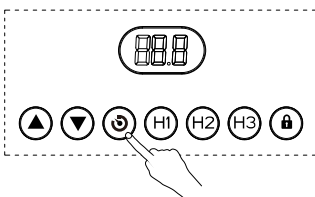

DISTRIBUTION NETWORK

Enter the network distribution mode by pressing and holding the "⊙" key on the hand controller for 10 seconds. At this time, the device can be found in the Add Device section of the APP interface.

ERROR CODE

ERROR CODES	CAUSE	SOLUTION
E01、E06 E07	Faulty power supply of the control box	Check the power supply
E02	Unbalanced legs	Reinitialize
E04	Hand controller connection or communication error	Check hand control cable
E05	stop in case of obstruction	Release the button and run again
E08	Desktop tilts protection	Reinitialize
HOT	Overheat protection	Please wait for the temperature to drop before use.
E11、E13 E21、E23 E31、E33 E41、E43	Loose connection between the legs and the control box	Check the connection cable (connect the adapter cable)
E12、E22 E32、E42	Overload or motor failure	Replace control box
E14、E17 E24、E27 E34、E37 E44、E47	Desk leg position sensor abnormality	Press the "+" key or the "-" key again. If the problem persists, please check whether the plug wire of the table leg is inserted in place.
E15、E25 E35、E45	Desk leg failure	If it cannot be eliminated after restarting, replace the desk legs.
E16、E26 E36、E46	Leg Stuck	Reinitialize
E18、E28 E38、E48	The load is too large, overloaded	Reduce load

INSTRUCTIONS D'UTILISATION

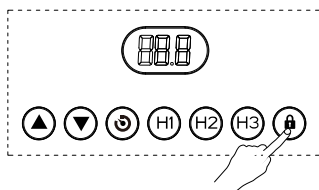

VERROUILLER ET DÉVERROUILLER

Verrouillage : Appuyez sur la touche "  " et maintenez-la enfoncée pendant 5 secondes, lorsque le tube numérique affiche "Loc", cela signifie que le système a été verrouillé et qu'il est impossible d'effectuer une opération de levage sur le système.

Déverrouillage : Appuyez sur la touche "  " et maintenez-la enfoncée pendant 5 secondes. Lorsque le tube numérique affiche "Loc", cela signifie que le système a été déverrouillé.

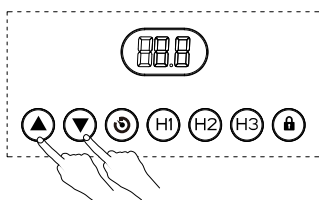

FONCTIONNEMENT DES TOUCHES HAUT ET BAS



Lorsque la touche "  " est enfoncée, le bureau monte vers le haut jusqu'à atteindre le point le plus élevé du bureau.

Lorsque la touche "  " est enfoncée, le bureau descend jusqu'à atteindre le point le plus bas du bureau.

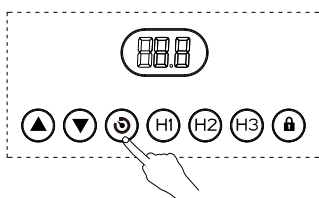
Lorsque vous cliquez sur la touche «  » ou «  », le bureau se déplace sur une petite distance en conséquence pour réaliser le jogging.



STOCKAGE DE LOCALISATION ET FONCTIONNEMENT DE LA MÉMOIRE



La télécommande dans l'image ci-dessus peut stocker 3 points mémoire. La méthode de stockage est la suivante. Lorsque vous courez vers un point spécifique, appuyez sur le bouton "  ". Le tube numérique affichera « S- » et «  » clignotera. À ce moment, appuyez sur la touche « H1-H3 » pour stocker la position actuelle sur l'étiquette correspondante.

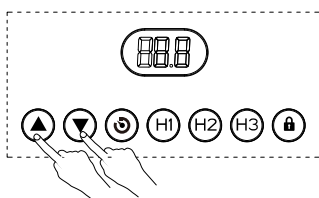

En mode entièrement automatique (S-6 est 1), si vous souhaitez courir jusqu'au point mémoire, il vous suffit de cliquer sur la touche correspondant à l'emplacement de stockage. À ce moment, le tube numérique affichera la hauteur de la position clé correspondante, puis se dirigera automatiquement vers l'emplacement stocké. En fonction de la hauteur, lors du fonctionnement, n'importe quelle touche peut arrêter le système.

En mode semi-automatique (S-6 est 0), si vous souhaitez courir jusqu'au point mémoire, il vous suffit de maintenir enfoncée la touche correspondant à la position de stockage. À ce moment, le tube numérique affichera la hauteur de la position clé correspondante, puis fonctionnera automatiquement jusqu'à la hauteur stockée. Pendant l'exécution, relâchez le bouton pour arrêter le système.



RÉGLAGE DES LIMITES HAUTE ET BASSE

Le système prend en charge la limite de hauteur du bureau. La méthode de fonctionnement est la suivante : lorsque vous souhaitez définir la hauteur actuelle comme hauteur limite du bureau, appuyez et maintenez les boutons "  " et "  " à la hauteur correspondante pendant 5 secondes. À ce moment-là, vous entendrez un signal sonore indiquant que le stockage dans un emplacement restreint a réussi. Lorsque la table se trouve dans la moitié supérieure de sa course, la position supérieure est restreinte. Lorsque le plateau de table se trouve dans la moitié inférieure de sa course, la position inférieure est limitée.

Annuler la limite de hauteur Méthode 1 : Réinitialisez le système à ce moment-là et la limite de hauteur du système sera annulée. Méthode 2 : laissez le bureau fonctionner jusqu' au point limite haut ou bas. À ce moment, maintenez enfoncés les boutons «  » et «  » en même temps pendant 5 secondes. Vous entendrez un signal sonore indiquant que la position limite a été annulée avec succès.

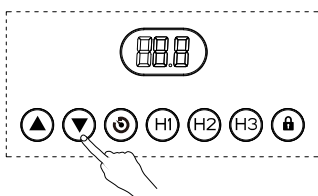

OPÉRATION D'INITIALISATION

Lorsque le système présente une anomalie ou que la télécommande affiche « RSL », il est nécessaire d'initialiser la table élévatrice. L'opération d'initialisation consiste à appuyer et à maintenir le bouton " ▼ " jusqu'à ce que le moteur s'arrête et à relâcher le bouton, puis à appuyer sur " ▼ " pendant 5 secondes pour entrer automatiquement. Mode d'initialisation. Ne relâchez pas le bouton " ▼ " pour le moment, si vous relâchez le bouton " ▼ ", le système arrête le mode d'initialisation. Une fois l'initialisation terminée, le buzzer émettra un message indiquant que l'initialisation est réussie.

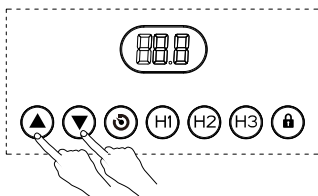

RÉINITIALISER

Lorsque le système est remplacé par un nouveau pied de table ou que les paramètres doivent être restaurés aux paramètres d'usine, appuyez et maintenez « ▲ » et « ▼ » en même temps pendant 10 secondes pour entendre une longue invite sonore et les paramètres sont restaurés aux paramètres d'usine. , initialisation forcée.

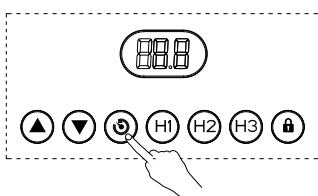

PARAMÈTRES INTERNES ET RÉGLAGES DE DISTANCE D'INSTALLATION

En appuyant et en maintenant la touche « ⏻ » de la télécommande pendant 5 secondes, vous pouvez accéder à l'interface de réglage, où « S-x » est affiché et « x » clignote, où « x » est le groupe de paramètres. À ce moment, appuyez sur « ⏻ » pour entrer dans le groupe de paramètres afin de définir les paramètres correspondants, et appuyez sur « ▲ » ou « ▼ » pour changer de groupe de paramètres. Après avoir défini les paramètres, appuyez sur la touche « ⏻ » pour revenir à l'interface en cours d'exécution.

Les paramètres pouvant être définis sont les suivants :

un. "S-1" 0 signifie affichage métrique, 1 signifie affichage impérial.

b. "S-2" indique la précision d'arrêt du capteur en cas d'obstruction, 0 indique éteint, 8 est le plus sensible et 1 est le moins sensible.

c. "S-3" indique la précision de l'arrêt du courant ascendant lorsqu'il rencontre une résistance, 0 indique l'arrêt, 8 est le plus sensible et 1 est le moins sensible.

d. "S-4" indique la précision de l'arrêt du courant descendant lorsqu'il rencontre une résistance, 0 indique l'arrêt, 8 est le plus sensible et 1 est le moins sensible.

e. "S-5" indique la distance d'installation en cm.

F. "S-6" 0 signifie appuyer sur la touche de position de stockage pour fonctionner, puis la relâcher pour arrêter de fonctionner, 1 signifie appuyer sur la touche de position de stockage pour courir automatiquement vers la position stockée et n'importe quelle touche pour arrêter.

g. "S-7" signifie 0 signifie éteindre le système de travail de 2 minutes et 18 minutes et compter uniquement sur le contrôleur de protection de la température, et 1 signifie allumer le système de travail de 2 minutes et 18 minutes.

h. "S-8" signifie l'inclinaison gauche et droite du bureau, la sensibilité, pour empêcher la tige de vis de se briser ou d'autres causes de hauteurs incohérentes des deux pieds de table. 0 signifie éteint, 1-8 signifie un angle d'inclinaison de 0,5 à 4° respectivement.

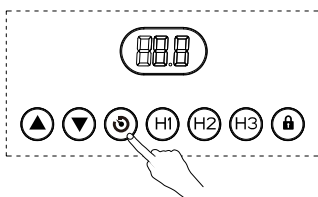

RÉSEAU DE DISTRIBUTION

Entrez dans le mode de distribution réseau en appuyant et en maintenant enfoncée la touche « ⏻ » de la télécommande pendant 10 secondes. À l'heure actuelle, l'appareil se trouve dans la section Ajouter un appareil de l'interface APP.

CODE D'ERREUR

CODE D'ERREUR	CAUSE	SOLUTION
E01、E06 E07	Anomalie d' alimentation du boîtier de commande	Vérifier l'alimentation électrique
E02	Jambes déséquilibrées	Réinitialiser
E04	Erreur de connexion ou de communication de la commande manuelle	Vérifier le câble de la commande manuelle
E05	s'arrêter en cas d'obstruction	Relâchez le bouton et exécutez à nouveau
E08	Protection contre l'inclinaison du bureau	Réinitialiser
HOT	Protection contre la surchauffe	Veillez attendre que la température baisse avant utilisation.
E11、E13 E21、E23 E31、E33 E41、E43	Connexion lâche entre les pieds et le boîtier de commande	Vérifier le câble de connexion (connecter le câble adaptateur)
E12、E22 E32、E42	Surcharge ou panne de moteur	Remplacer le boîtier de commande
E14、E17 E24、E27 E34、E37 E44、E47	Anomalie du capteur de position du pied de table	Appuyez à nouveau sur la touche "+" ou sur la touche "-". Si le problème persiste, veuillez vérifier si le fil de fiche du pied de table est bien inséré.
E15、E25 E35、E45	Échec du pied de bureau	S'il ne peut pas être éliminé après le redémarrage, remplacez les pieds du bureau.
E16、E26 E36、E46	Jambe coincée	Réinitialiser
E18、E28 E38、E48	La charge est trop importante, surchargée	Réduire la charge

INSTRUCCIONES DE USO

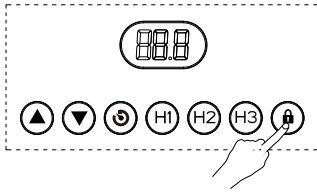

TRABAR Y DESTRARBAR

Bloqueo: Pulse y mantenga pulsada la tecla "🔒" durante 5 segundos, cuando el tubo digital muestre "Loc", significa que el sistema ha sido bloqueado, y es imposible realizar operaciones de elevación en el sistema.

Desbloquear: Pulse y mantenga pulsada la tecla "🔒" durante 5 segundos, cuando el tubo digital muestre "Loc" en la pantalla digital normal, significa que el sistema ha sido desbloqueado.

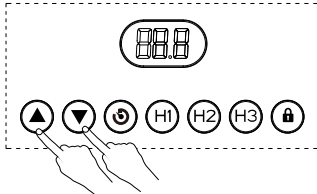

OPERACIÓN DE TECLAS ARRIBA Y ABAJO

Cuando se presiona la tecla "▲", el escritorio corre hacia arriba hasta llegar al punto más alto del escritorio.

Cuando se presiona la tecla "▼", el escritorio corre hacia abajo hasta llegar al punto más bajo del escritorio.

Cuando se hace clic en la tecla "▲" o "▼", el escritorio se mueve una pequeña distancia en consecuencia para realizar el jogging.

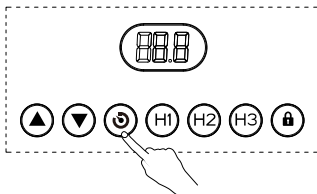

ALMACENAMIENTO DE UBICACIÓN Y OPERACIÓN DE MEMORIA

El controlador manual en la imagen de arriba puede almacenar 3 puntos de memoria. El método de almacenamiento es el siguiente. Cuando corras hacia un punto específico, presiona el botón "S". El tubo digital mostrará "S-" y "▼" parpadeará. En este momento, presione la tecla "H1-H3" para almacenar la posición actual en la etiqueta correspondiente.

En modo completamente automático (S-6 es 1), si desea ejecutar hasta el punto de memoria, solo necesita hacer clic en la tecla correspondiente a la ubicación de almacenamiento. En este momento, el tubo digital mostrará la altura de la posición clave correspondiente y luego se ejecutará automáticamente hasta la ubicación almacenada. En correspondencia con la altura, cuando está en funcionamiento, cualquier tecla puede detener el sistema.

En modo semiautomático (S-6 es 0), si desea correr hasta el punto de memoria, solo necesita seguir presionando la tecla correspondiente a la posición de almacenamiento. En este momento, el tubo digital mostrará la altura de la posición clave correspondiente y luego correrá automáticamente hasta la altura almacenada. Mientras está en funcionamiento, suelte el botón para detener el sistema.

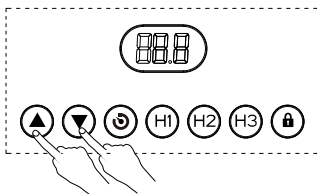

CONFIGURACIÓN DE LÍMITE ALTO Y BAJO

El sistema admite el límite de altura del escritorio. El método de operación es: cuando desee establecer la altura actual como altura límite del escritorio, presione y mantenga presionados los botones "▲" y "▼" en la altura correspondiente durante 5 segundos. En este momento, escuchará un timbre que indica que el almacenamiento en ubicación restringida se realizó correctamente. Cuando la mesa se encuentra en la mitad superior de su recorrido, la posición superior está restringida. Cuando el tablero de la mesa está en la mitad inferior de su recorrido, la posición inferior está restringida.

Cancelar el límite de altura Método 1: Reinicie el sistema en este momento y se cancelará el límite de altura del sistema. Método 2: Deje que el escritorio se ejecute hasta el límite máximo o mínimo. En este momento, mantenga presionados los botones "▲" y "▼" al mismo tiempo durante 5 segundos. Escuchará un timbre que indica que la posición límite se canceló exitosamente.

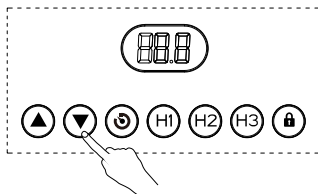

OPERACIÓN DE INICIALIZACIÓN

Cuando el sistema es anormal o el controlador manual muestra "RSL", es necesario inicializar la mesa elevadora. La operación de inicialización consiste en presionar y mantener presionado el botón "▼" hasta que el motor se detenga y soltar el botón, y luego presionar "▼" durante 5 segundos para ingresar automáticamente. Modo de inicialización. No suelte el botón "▼" en este momento; si suelta el botón "▼", el sistema detendrá el modo de inicialización. Una vez completada la inicialización, el zumbador emitirá un mensaje que indica que la inicialización se realizó correctamente.

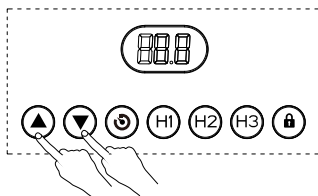

REINICIAR

Cuando se reemplaza el sistema con una nueva pata de la mesa, o es necesario restaurar los parámetros a la configuración de fábrica, presione y mantenga presionados "▲" y "▼" al mismo tiempo durante 10 segundos para escuchar un timbre largo y los parámetros se restablecen a la configuración de fábrica. , inicialización forzada.

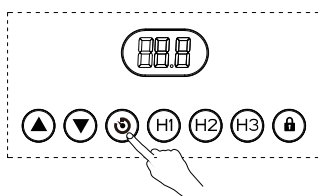

PARÁMETROS INTERNOS Y AJUSTES DE DISTANCIA DE INSTALACIÓN

Al presionar y mantener presionada la tecla "⚙️" en el controlador manual durante 5 segundos, puede ingresar a la interfaz de configuración, donde se muestra "S-x" y "x" parpadea, donde "x" es el grupo de parámetros. En este momento, presione "⚙️" para ingresar al grupo de parámetros para configurar los parámetros correspondientes y presione "▲" o "▼" para cambiar los grupos de parámetros. Después de configurar los parámetros, presione la tecla "⚙️" para volver a la interfaz en ejecución.

Los parámetros que se pueden configurar son los siguientes:

- a. "S-1" 0 significa visualización métrica, 1 significa visualización imperial.
- b. "S-2" indica la precisión de parada del sensor cuando encuentra una obstrucción, 0 indica apagado, 8 es el más sensible y 1 es el menos sensible.
- c. "S-3" indica la precisión de detener la corriente ascendente cuando encuentra resistencia, 0 indica apagado, 8 es el más sensible y 1 es el menos sensible.
- d. "S-4" indica la precisión de detener la corriente descendente cuando encuentra resistencia, 0 indica apagado, 8 es el más sensible y 1 es el menos sensible.
- mi. "S-5" indica la distancia de instalación en cm.
- F. "S-6" 0 significa presionar la tecla de posición de almacenamiento para ejecutar y luego soltarla para detener el funcionamiento, 1 significa presionar la tecla de posición de almacenamiento para ejecutar automáticamente a la posición almacenada y cualquier tecla para detener.
- gramo. "S-7" significa 0 significa apagar el sistema de trabajo de 2 minutos y 18 minutos y confiar únicamente en el controlador de protección de temperatura, y 1 significa encender el sistema de trabajo de 2 minutos y 18 minutos.
- h. "S-8" significa la inclinación izquierda y derecha del escritorio, sensibilidad, para evitar que la varilla roscada se rompa u otras causas de alturas inconsistentes de las dos patas de la mesa. 0 significa apagado, 1-8 significa un ángulo de inclinación de 0,5-4° respectivamente.

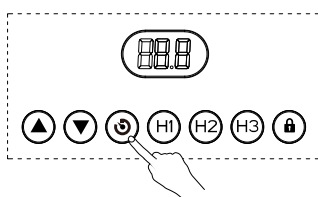

RED DE DISTRIBUCIÓN

Ingrese al modo de distribución de red presionando y manteniendo presionada la tecla "⚙️" en el controlador manual durante 10 segundos. En este momento, el dispositivo se puede encontrar en la sección Agregar dispositivo de la interfaz de la aplicación.

CÓDIGO DE ERROR

CODE D'ERREUR	CAUSE	SOLUTION
E01、 E06 E07	Anomalía en la fuente de alimentación de la caja de control	Compruebe el suministro eléctrico
E02	Piernas desequilibradas	Reinicializar
E04	Conexión del mando manual o error de comunicación	Compruebe el cable del control manual
E05	detenerse en caso de obstrucción	Suelta el botón y ejecuta de nuevo.
E08	Protección contra inclinación del escritorio	Reinicializar
HOT	Protección contra el sobrecalentamiento	Espere a que la temperatura baje antes de usarlo.
E11、 E13 E21、 E23 E31、 E33 E41、 E43	Conexión suelta entre las patas y la caja de control.	Compruebe el cable de conexión (conecte el cable adaptador)
E12、 E22 E32、 E42	Sobrecarga o falla del motor	Reemplace la caja de control
E14、 E17 E24、 E27 E34、 E37 E44、 E47	Anomalía en el sensor de posición de las patas de la mesa	Presione la tecla "+" o la tecla "-" nuevamente. Si el problema persiste, verifique si el cable del enchufe de la pata de la mesa está insertado en su lugar.
E15、 E25 E35、 E45	Fallo en la pata del escritorio	Si no se puede eliminar después de reiniciar, reemplace las patas del
E16、 E26 E36、 E46	Pierna atascada	Reinicializar
E18、 E28 E38、 E48	La carga es demasiado grande, sobrecargada.	Reducir la carga

升降操作说明

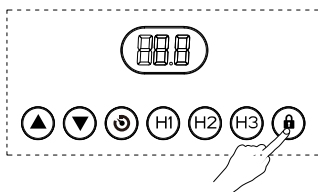

锁定和解锁

锁定：按住“”键5秒，当数码管显示“Loc”，此时表示系统已经锁定，无法对系统做升降操作。

解锁：按住“”键5秒，当数码管从“Loc”显示到正常数字显示，表示系统已经解锁。

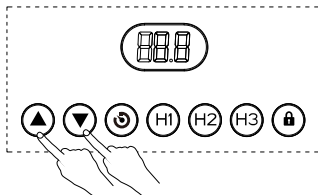

上下键操作



当按下“”键，桌面向上运行，直到到达桌面的最高点。

当按下“”键，桌面向下运行，直到到达桌面的最低点。

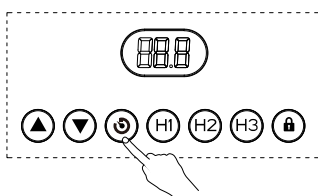
当短按“”或者“”键，桌面相应运行很小的距离，实现点动。



位置存储和记忆运行



上图手控器可以存储3个记忆点，存储方法如下，当运行到特定的点时候，此时按“”键，数码管显示“S-”，同时“”闪烁，此时按“H1-H3”键，存储此时位置到对应标号。

在全自动模式下（S-6为1）如果要运行到记忆点，此时只需要按一下对应存储位置的标号，此时数码管会显示对应标号位置的高度，然后自动运行到位置存储的对应高度，运行的时候，任意键能够停止系统。

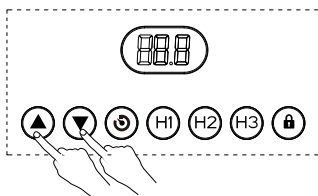
在半自动模式下（S-6为0）如果要运行到记忆点，此时只需要一直按着对应存储位置的标号，此时数码管会显示对应标号位置的高度，然后自动运行到位置存储的对应高度，运行的时候，松开按键停止系统。





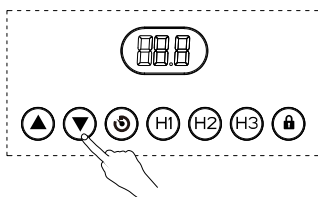

高低限位设定

系统支持桌面高低高度限定，操作方法为，当要设定当前高度为桌面限制高度，在对应高度同时按住“”和“”按键5秒，此时会听到蜂鸣器声音，表示限制位置存储成功，当桌子处于行程上半部分的时候，限制的是高位，当桌面处于桌子行程的下半部分的时候，限制的是最低位置。



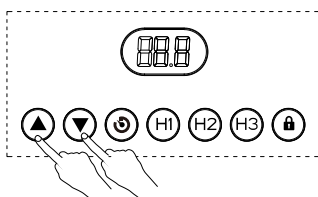

初始化操作

当系统出现异常，或者手控器显示“RSL”，则需要对升降桌进行初始化，初始化为，按住“”按键，直到电机停止后松开按键，再按“”按键5S，自动进入初始化模式。此时不能松开“”键，若松开“”按键系统停止初始化模式。初始化完成，蜂鸣器会发出提示音，表示初始化成功。



恢复出厂设置

当系统换装到新的桌腿，或者参数需要恢复到出厂的设定，此时同时按住“”和“”10秒听到长一声蜂鸣器提示，此时参数恢复到出厂状态，强制初始化。

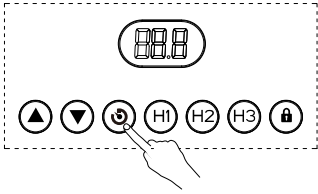

内部参数和安装距设定

通过长按手控器“S”键5秒，可以进入设置界面，显示“S-x”同时“x”闪烁，其中“x”为参数组。此时按“S”可以进入参数组设置对应的参数，按“▲”或者“▼”切换参数组。设定完参数通过按“S”键，返回运行界面。

可以设定的参数如下：

- a、“S-1” 0表示公制显示，1表示英制显示。
- b、“S-2”表示传感器遇阻停精度，0表示关闭，8最灵敏，1最不灵敏。
- c、“S-3”表示向上电流遇阻停精度，0表示关闭，8最灵敏，1最不灵敏。
- d、“S-4”表示向下电流遇阻停精度，0表示关闭，8最灵敏，1最不灵敏。
- e、“S-5”此时表示安装距，单位为cm。
- f、“S-6” 0表示按存储位置键运行松掉停止运行，1表示按存储位置键自动运行到存储的位置，任意键停止。
- g、“S-7”表示0表示关闭2分钟18分钟工作制，仅靠温度保护控制器，1表示开启2分钟18分钟工作制。
- h、“S-8”表示桌面左右倾斜，灵敏度，防止丝杆断裂或者其他引起的二个桌腿高度不一致，0表示关掉，1-8分别表示0.5-4°的一个倾斜角度。

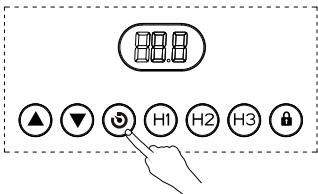

配网模式设置

通过长按手控器“S”键10秒，进入配网模式。此时APP界面添加设备处可查找到设备。

错误代码

故障代码	原因	处理方式
E01、E06 E07	控制盒电源异常	检查电源
E02	两侧桌腿位置不平衡	重新初始
E04	手控器连接或者 通讯错误	检查手控器线
E05	遇阻停显示	松开按键，重新运行。
E08	桌面倾斜保护	重新初始化
HOT	过温保护	等待温度下降后再使用
E11、E13 E21、E23 E31、E33 E41、E43	桌腿与控制盒未连接	检查连接线 (把转接线接上)
E12、E22 E32、E42	传感器或电机故障	更换控制盒
E14、E17 E24、E27 E34、E37 E44、E47	桌腿位置传感器异常	重新按上键或者下键，仍然存在，请检查桌腿的插头线是否插到位。
E15、E25 E35、E45	桌腿故障	重启后无法消除，更换桌腿
E16、E26 E36、E46	桌腿机械卡死	重新初始化
E18、E28 E38、E48	负载太大，过载	减少负载