

Assembly Guide & User Manual

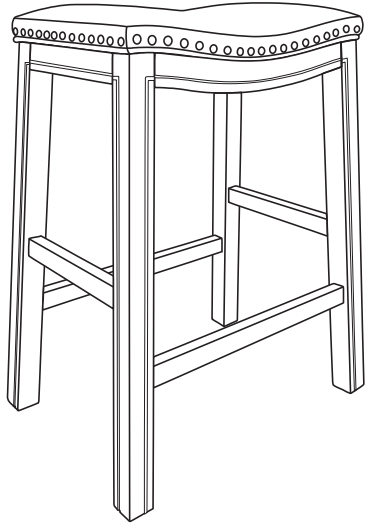

Nailhead Trim Saddle Bar Stool



Phillips #2 (PH2) Needed (NOT INCLUDED)



minutes

The expected assembly time is 20 Minutes.



We recommend 2 or more people to install.



We recommend wearing protective gloves.

⚠️ WARNING

Read all instructions before assembly.

Failure to follow these instruction may result in injury or product damage.



IMPORTANT WARRANTY INFORMATION

PLEASE READ CAREFULLY

AFTER-SALES CONTACT US

If you have any problems or dissatisfaction with the product, don't hesitate to contact the after-sales team to solve the problems or express your feelings or concerns. We **DO VALUE** your voices and are all the time ready to help. All the calls, emails and messages from you will get our immediate reply within 24 hours.

All items can be returned or replaced for any reason within 30 days of the receipt as long as the item is returned in its original product package and all accessories of its original shipment are included.

About Replacement:

If there are missing parts or damages when you receive the item, you don't need to return it if you want to get a replacement. Please contact the after-sales team

About Returns:

1. If you need to return product, please contact us

We will provide a **PREPAID RETURN LABEL** by E-mail.







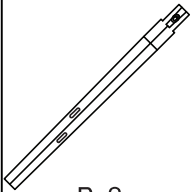
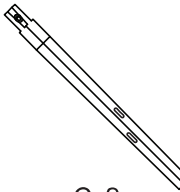

Please include a brief description of the problem and photos of the damaged product in your email.

2. **Please Note: If the customer does not contact the after-sales team to get a return label and the customer purchases the return label by themselves, it may incur expensive return shipping charges. And the seller will not bear the fee of the customer's own purchase of the return label**
3. If the product is damaged by the customer, we can refuse to provide a prepaid return label, and the customer needs to pay for the return shipping.
4. Boxes for return shipping will not be provided by the seller. The customers are responsible for using the original shipping boxes, or purchasing new boxes when no boxes.
5. After all returned items arrive at the Return Center, please contact the After-sales team and we will fully refund back to the original payment method.

WARRANTY:

Please keep the after-sale card. If the product is damaged by non-human factors within six months, please contact our after-sales team.

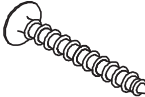
COMPONENTS

<p>Seat Cushion</p>  <p>Ax1</p>	<p>Chair Leg "L"</p>  <p>Bx2</p>	<p>Chair Leg "R"</p>  <p>Cx2</p>	<p>Side Crossbar</p>  <p>Dx2</p>	<p>Front back Footrest</p>  <p>Ex2</p>
<p>Hex Bolt M8 × 60mm $\frac{5}{16}$" × $2\frac{3}{8}$"</p>  <p>Fx4</p>	<p>Lock Washer M8 ($\frac{5}{16}$")</p>  <p>Gx4</p>	<p>Flat Washer M8 ($\frac{5}{16}$")</p>  <p>Hx4</p>	<p>Wood Screw #8 × $1\frac{1}{2}$"</p>  <p>Ix8</p>	<p>Hex Key 5mm ($\frac{5}{16}$")</p>  <p>Jx1</p>

Hardware Guide (1:1 Scale)

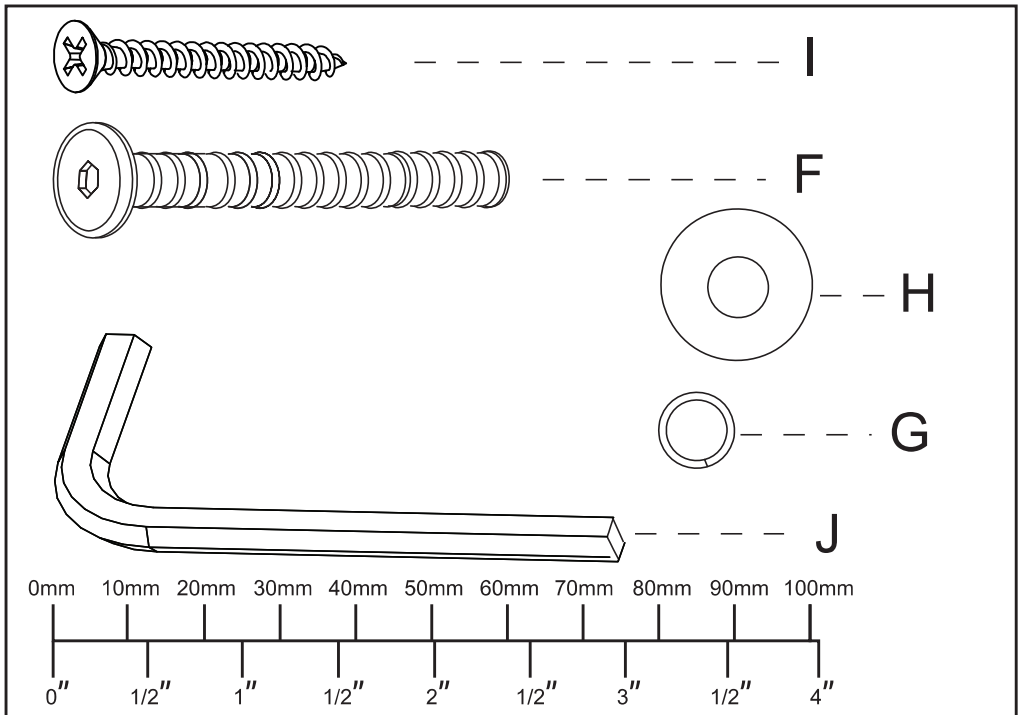

SAFETY INFORMATION



WARNING

- **WEIGHT CAPACITY:** 400 lbs (180 kgs).

Exceeding this limit may cause structural failure.

- **FALL HAZARD:** Do not stand on this stool. or use it as a step ladder.

- **TIP-OVER HAZARD:** Use only on level floors.

- **CHOKING HAZARD:** Small parts. This assembly kit contains small screws. Not for children under 3 years. Adult assembly required. Keep plastic bags and small parts away from children during assembly.

ASSEMBLY INSTRUCTION

Step 1. MATCH L & R

Place seat (A) face down on a soft surface. Look for labels on the seat bottom corners.

- Legs L (B) → Corners L (Top-Left & Bottom-Right)
- Legs R (C) → Corners R (Bottom-Left & Top-Right)

A		×1
B		×2
C		×2

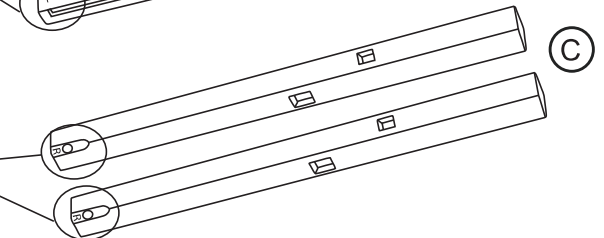
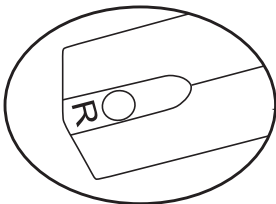
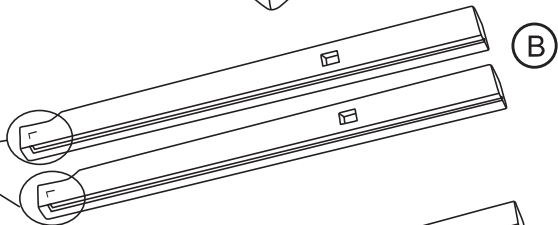
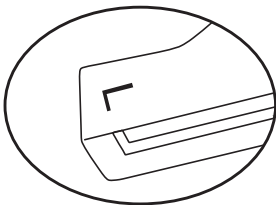
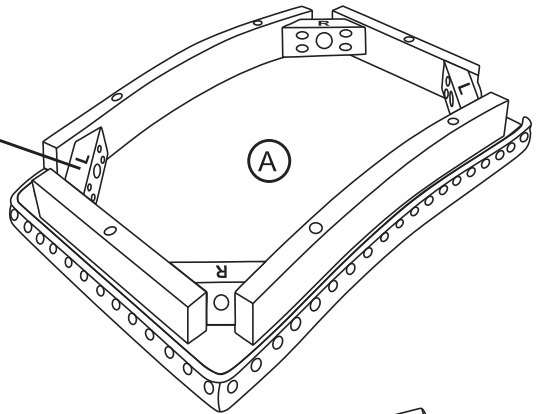
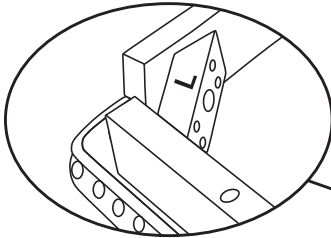

Step 2. ATTACH LEGS (LOOSELY!)

Insert bolts (F) with washers (Lock Washer (G) first, then Flat Washer (H)).





Hex Bolt M8 × 60mm
($\frac{5}{16}$ ") ($2\frac{3}{8}$ ")



Lock Washer M8
($\frac{5}{16}$ ")

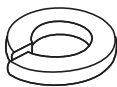

Flat Washer M8
($\frac{5}{16}$ ")

F		×4
G		×4
H		×4

● STOP! CRITICAL TIP: Do NOT fully tighten bolts yet!

Only tighten 50% by hand. The legs need to wiggle to fit the footrests.

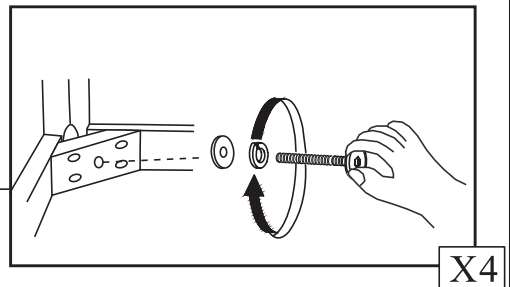
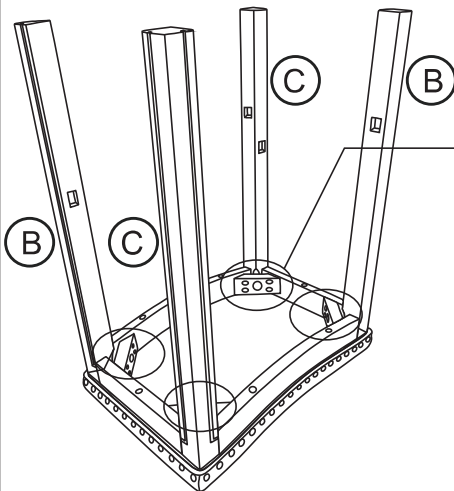

X4

Step 3. INSERT CROSSBARS



Identify the bars and insert into the loose legs.

Angled screw holes must face DOWN.

Side Crossbar (Short) (D): Place on the **High** holes.

Front/Back Footrest (Long) (E): Place on the **Low** holes.

Action: Tighten wood screws with your **PH2 Screwdriver**
(**NOT INCLUDED** in hardware kit).

D		x2
E		x2
I		x8

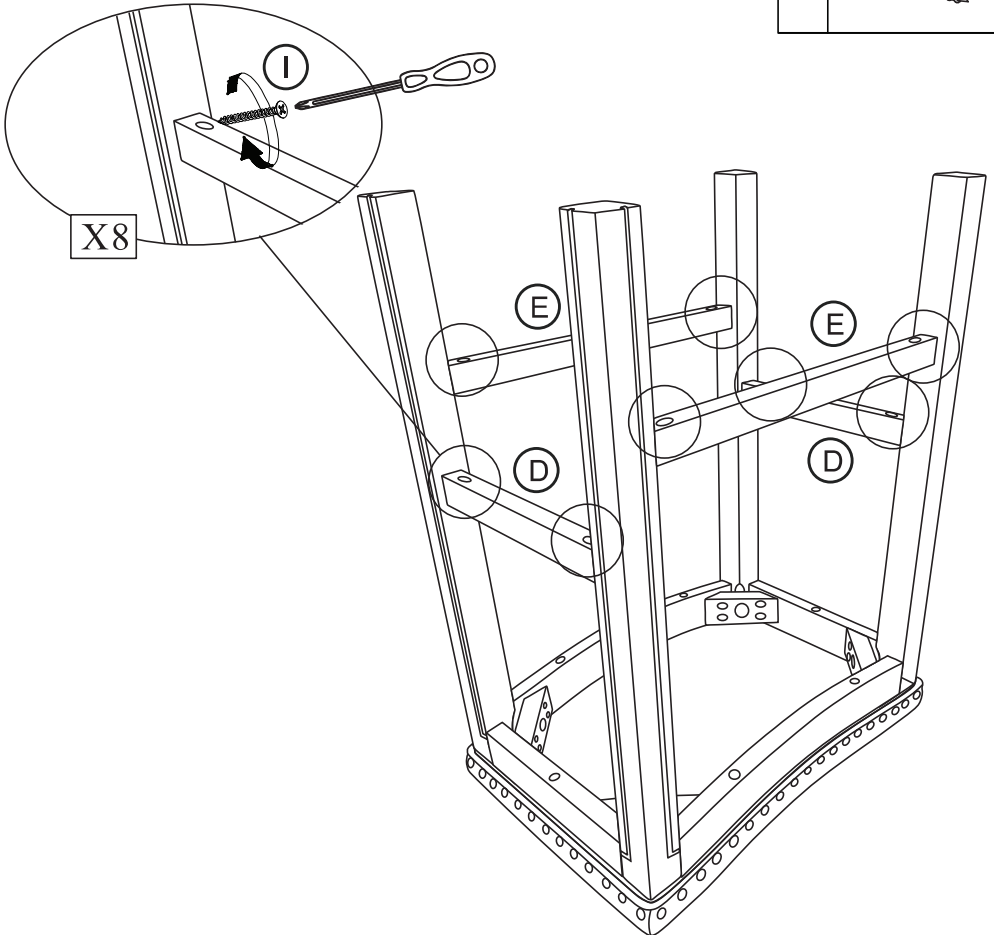

Step 4. The “Golden Leveling” Protocol (Tighten Now)

This is the step most people skip, but it is the most critical.

- 1. Stand Up:** Turn the stool upright and place it on a flat floor.
- 2. The Drop:** Lift the stool about 6 inches off the ground and drop it gently. This helps the legs self-align to the floor.
- 3. Apply Pressure:** The stool may still wobble. Sit on it gently (or press down firmly on the seat). Your weight will force all four legs to contact the floor evenly.
- 4. Final Tightening:** While maintaining this downward pressure, reach underneath and fully tighten (100%) all the main leg bolts (F) with the Hex Key (J).

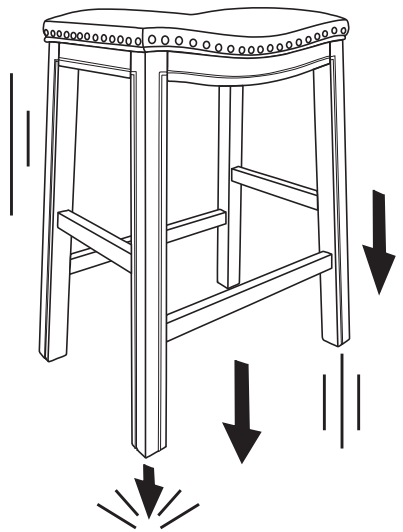
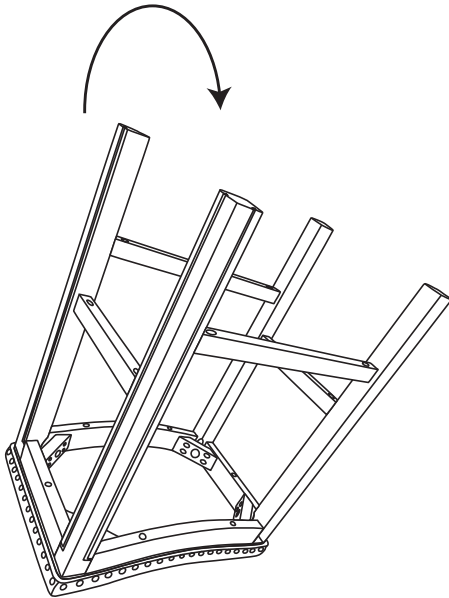

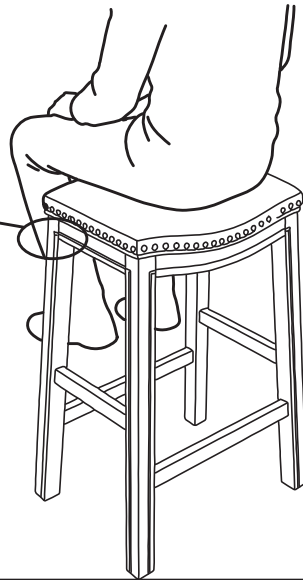
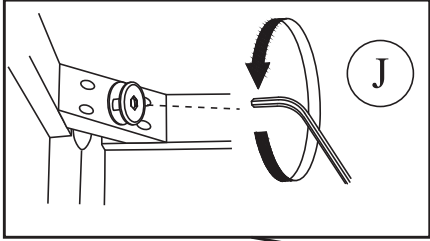

Assembly Complete

Your Saddle Bar Stool should now be rock-solid. If slight wobbling occurs months later due to humidity changes, simply repeat **Step 4**.

CARE

Wipe with a soft, damp cloth. Do not use abrasive cleansers.

MAINTENANCE REQUIREMENT

Hardware may loosen over time. Periodically check and retighten all bolts (F). We recommend checking 2 weeks after assembly and every 6 months thereafter.