

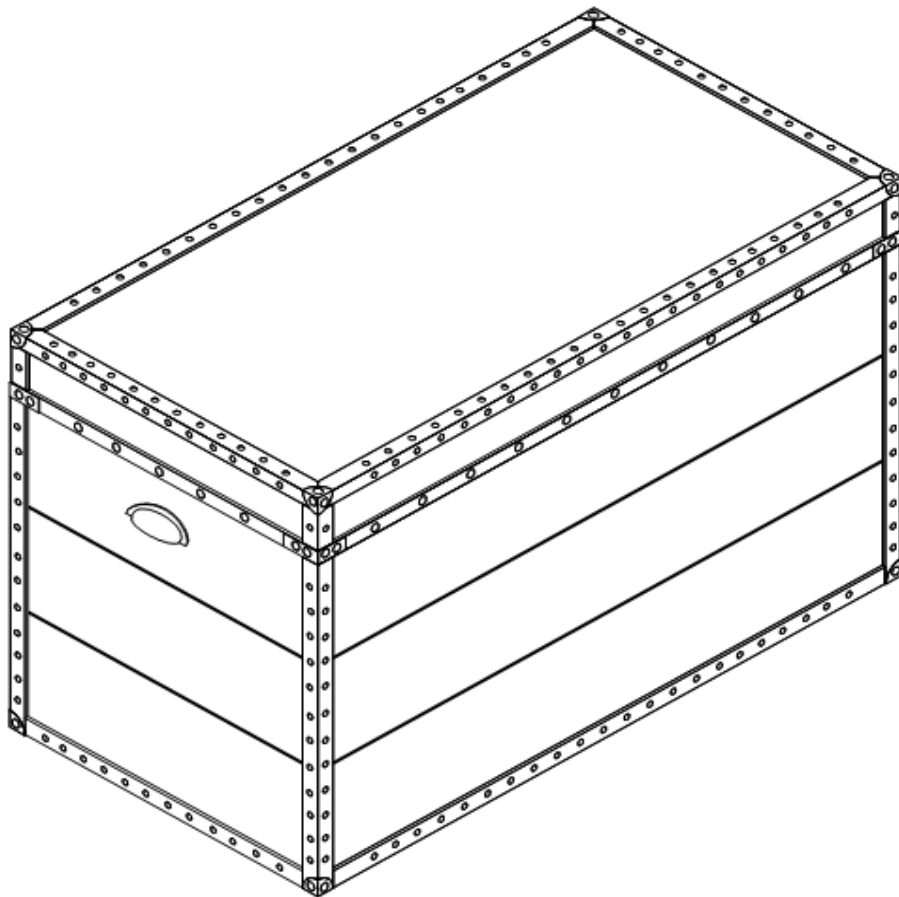









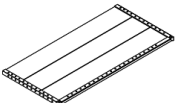
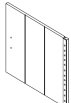
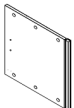
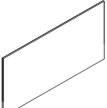
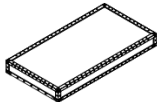
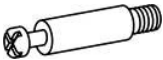

Trunk Table Assembly Instruction

Max top load 30lb and inside load 50lb.

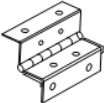

Trunk Table Parts List

Please review all parts and hardware before disposing of any packaging. Call Customer Service if missing hardware. Do not return to store/retailer. Screws shown actual size. Using a screw that is too long will cause damage. Before beginning assembly, separate each type of screw. Carefully study the screw diagrams below. You may receive extra hardware with your unit.

| | | |
|---|---|---|
| A  Quantity Of 1 Back Panel | B  Quantity Of 1 Front Panel | C  Quantity Of 1 Left Side Panel |
| D  Quantity Of 1 Right Side Panel | E  Quantity Of 1 Bottom Panel | F  Quantity Of 1 Top |
| 1  Quantity Of 12 Cam Bolt $\frac{1}{4}$ "x1-1/2" | 2  Quantity Of 12 Cam Lock $\frac{5}{8}$ "x1/2" | 3  Quantity Of 1 Left-Support |
| 4  Quantity Of 1 Right-Support | 5  Quantity Of 8 Screw $\frac{1}{8}$ "x1/2" | 6  Quantity Of 2 Hinge |
| 7  Quantity Of 24 Screw $\frac{1}{8}$ "x5/8" | 8  Quantity Of 2 Handle | 9  Quantity Of 4 Bolts $\frac{5}{32}$ " x1/2" |
| 10  Quantity Of 4 Bracket | 11  Quantity Of 2 Adhesive Pad | |

Care and Cleaning Instructions:
Before using, wipe with a clean, dry cloth.

Periodically apply furniture wax to renew The finish. Avoid rubbing or scratching the surface with rough or abrasive objects.

For replacement parts or questions, please call Customer Service. Do not return product to store.

Assembly Tool Required

No.2 Phillips Screw Driver



Trunk Table Assembly Instruction

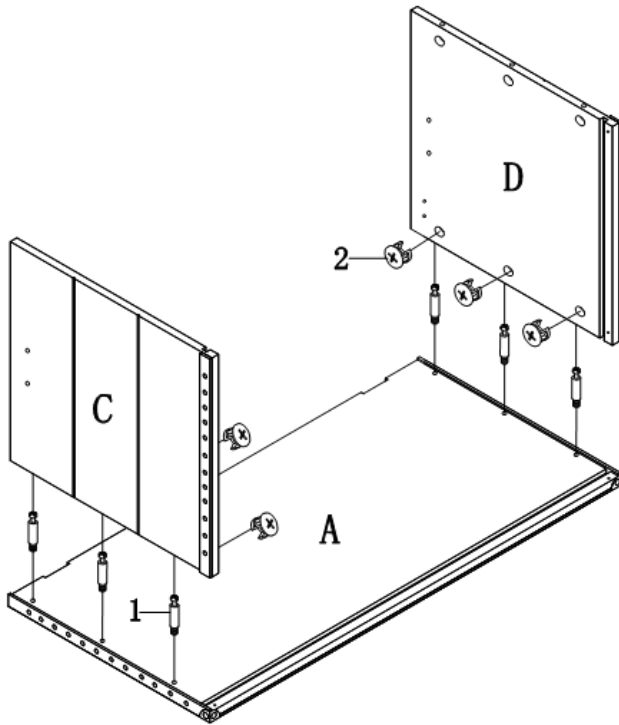

Step 1:
Attach left side panel (C)
and right side panel (D) to
back panel (A) by using cam
bolt (1) and cam lock (2) as
shown.

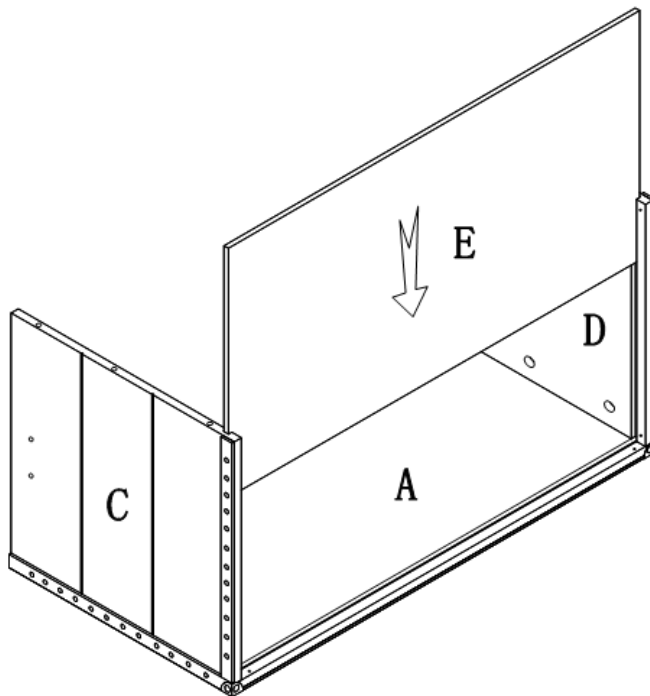

Step 2:
Insert bottom panel (E) to
the groove side panel as
shown.

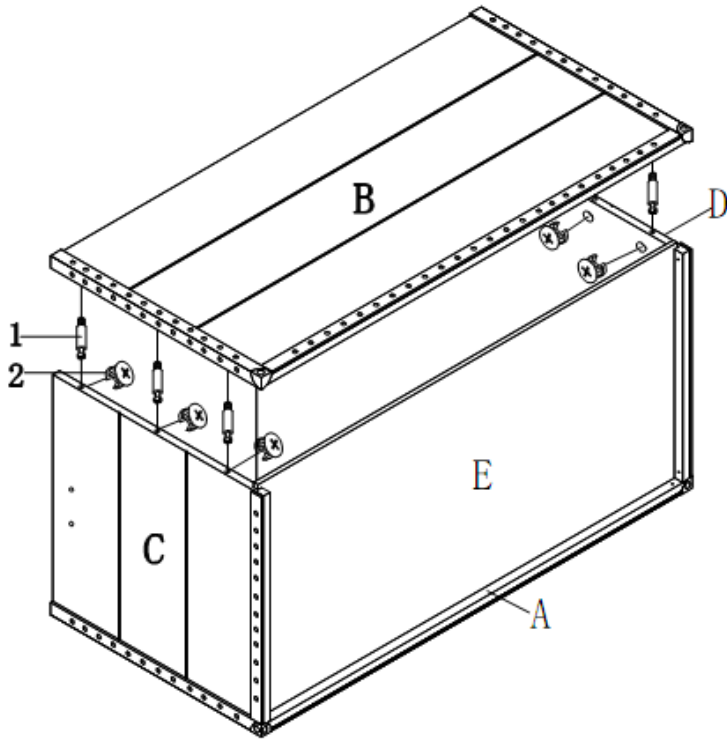

Step 3:
Attach front panel (B) to the frame by using cam bolt (1) and cam lock (2) as shown.

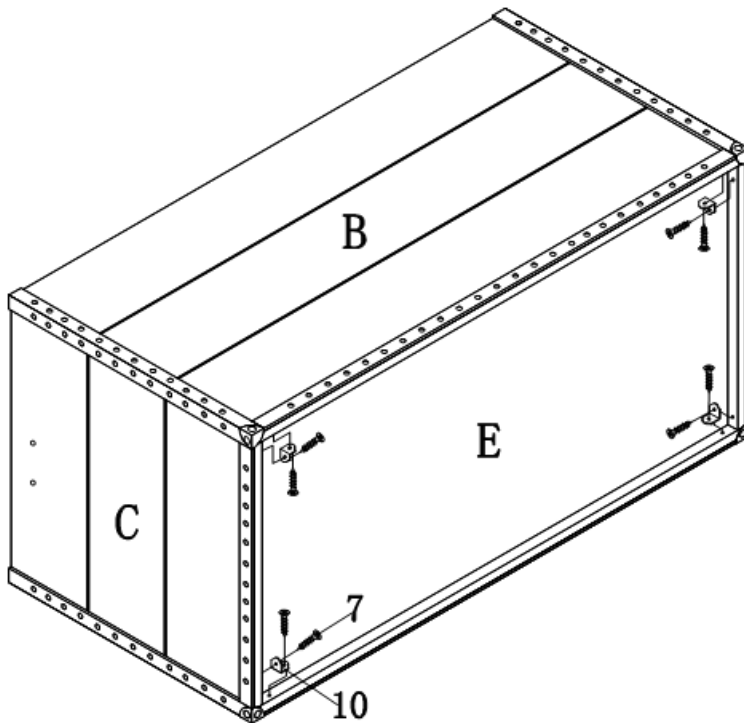

Step 4:
Using bracket (10) to fix the bottom corners of side panels as shown.

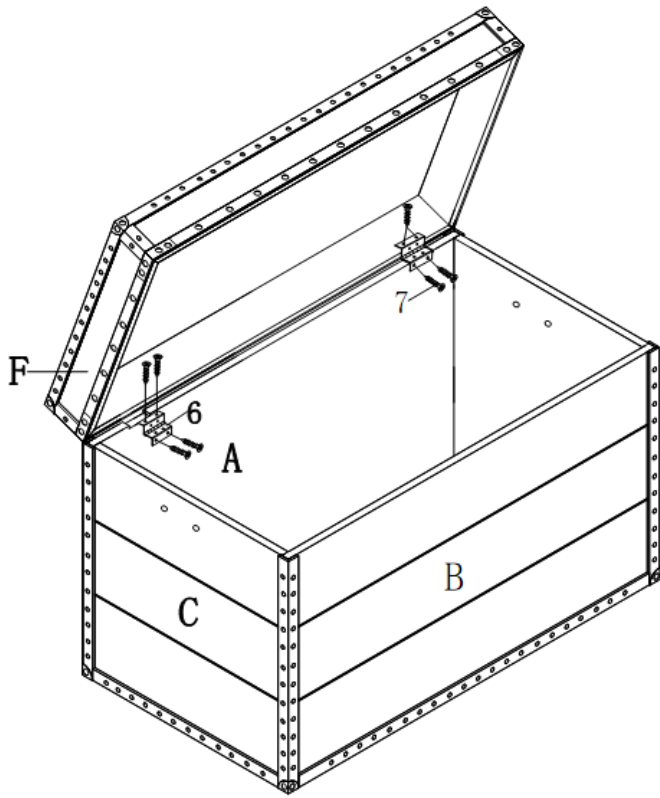

Step 5:
 Attach top (F) to the trunk base by using screw (7) and Phillips screw driver to tighten hinge (6) it as shown.

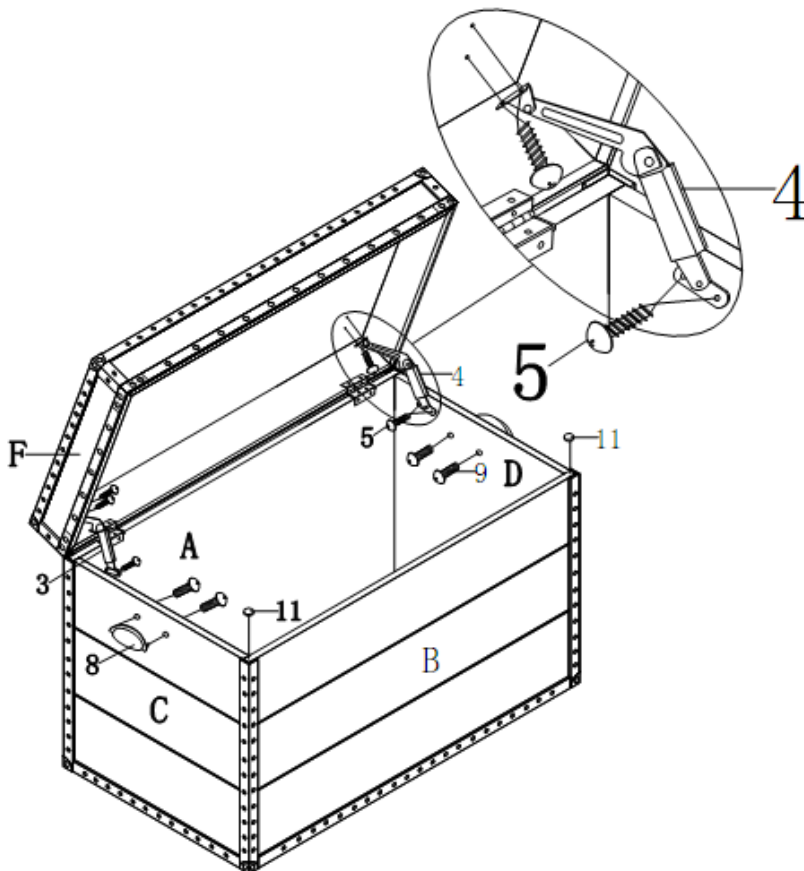

Step 6:
 Attach support (3) (4) to the top (F) and trunk base by using screw (5) as shown.

Attach handle (8) on side panel (C) (D) by using bolts (9) as shown.

Then put adhesive pad (11) on front panel (B) as shown, close the top and leave the top to drop down slowly.

Noted: Please do not open the lid all the way back.

We'd love to hear from you! Email us photos of our products in your home and we might feature it on our site or use it to model one of our inspirational photos.

“PARTS WILL BE SENT IF AVAILABLE ”

Parts Replacement Form

Customer Information

Name _____

Address _____

City/State/Zip Code _____

Phone Number _____

Please indicate where you purchased this item: Store/ Website/ Catalog

Please indicate color/size/style number:

Style No

Parts Letter

Parts Description

Quantity Needed

Missing or damaged hardware and/ or parts will be replaced free of charge. We do not sell parts. We will provide replacement parts for only those items purchased within the last 9 months. If this product has not been purchased from our retail affiliates (within 9 months), we are under no obligation to provide parts or replacements merchandise. Parts will not be available for items arriving fully assembled.