

# PARTS LIST

Your Reclining Chair should include the following parts. Please inspect box contents to ensure you have received all components.

You will NOT need additional tools for assembly.

**A**

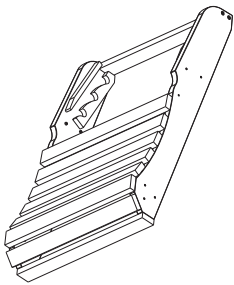

**SEAT (1)**

**B**

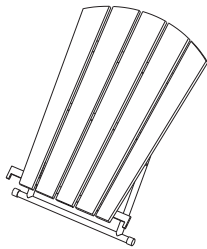

**BACKREST (1)**

**C**

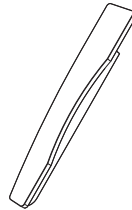

**LEFT ARMREST  
(1)**

**D**

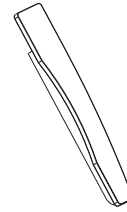

**RIGHT ARMREST  
(1)**

**E**



**LEFT FRONT  
LEG (1)**

**F**

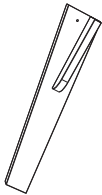

**RIGHT FRONT  
LEG (1)**

**G**



**LEFT SUPPORT  
(1)**

**H**

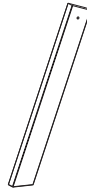

**RIGHT SUPPORT  
(1)**

**I**



**NUT (2)**

**J**



**WASHER (2)**

**K**

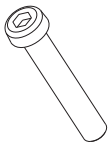

**SCREW (16)  
M6 X 35**

**L**



**HEX KEY (1)**

**M**

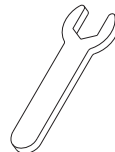

**WRENCH (1)**

# ASSEMBLY INSTRUCTIONS

## STEP 1

*NOTE: Make sure you have parts labeled (C), (E) and (G) for this step. They look very similar to parts (D), (F), and (H).*

Lay SEAT (A) on ground sideways as shown, orient (3) insert nuts on LEFT FRONT LEG (E) to align with (3) holes on SEAT (A). Insert (3) SCREWS (K), from inside, through SEAT (A) and hand fasten to LEFT FRONT LEG (E). Then with HEX KEY (L) tighten (3) SCREWS (K).

Orient (2) insert nuts on LEFT SUPPORT (G) to align with (2) holes on SEAT (A). Insert (2) SCREWS (K), from inside, through SEAT (A) and hand fasten to LEFT SUPPORT (G). Then with HEX KEY (L) tighten (2) SCREWS (K).

Put LEFT ARMREST (C) on LEFT FRONT LEG (E) and LEFT SUPPORT (G), making sure holes are aligned with insert nuts. Insert SCREW (K) through LEFT ARMREST (C) and hand fasten to LEFT FRONT LEG (G). Insert SCREW (K) through LEFT ARMREST (C) and hand fasten to LEFT SUPPORT (G). Finally tighten both SCREWS (K) with HEX KEY (L).

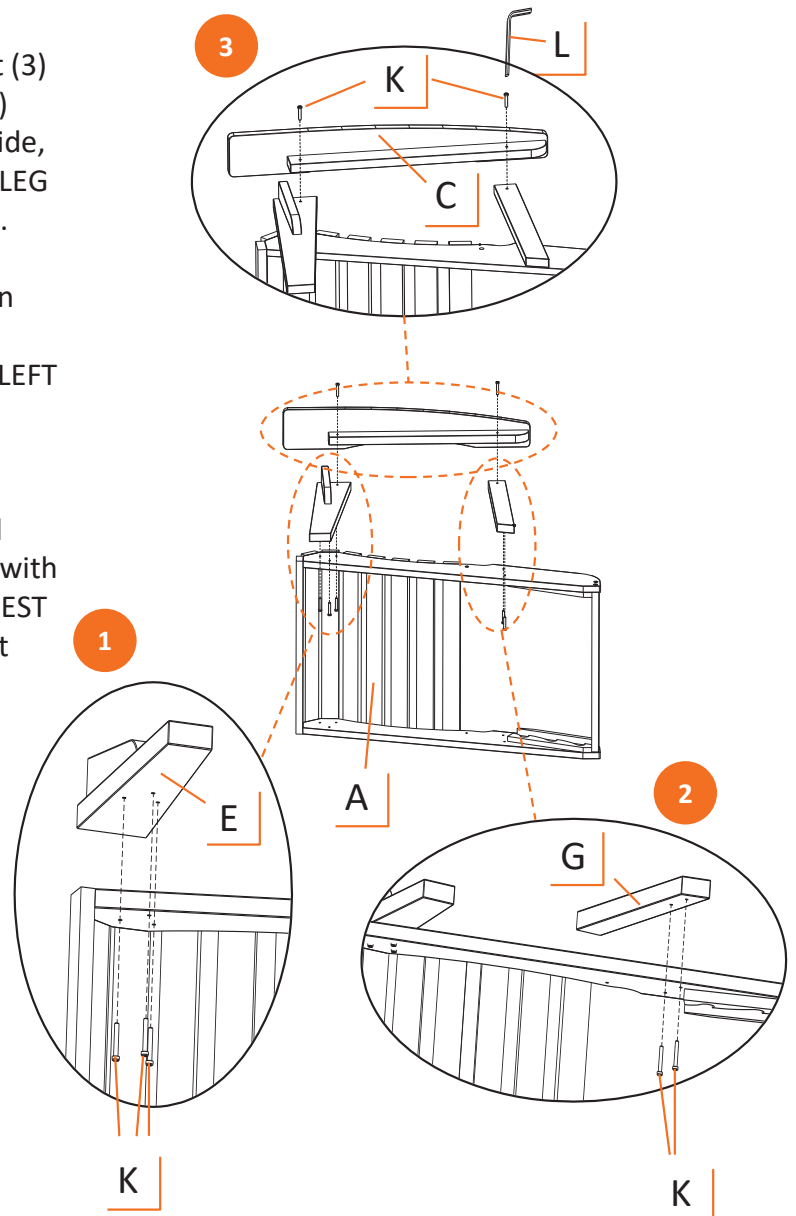
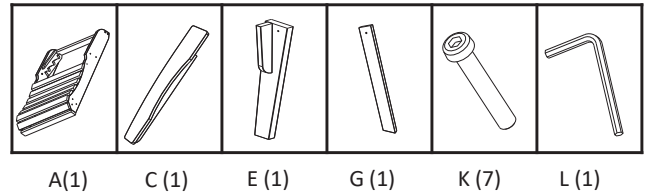

Completed STEP 1 assembly

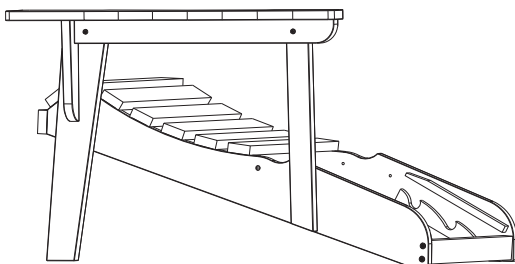

# ASSEMBLY INSTRUCTIONS

## STEP 2

Flip over completed assembly from STEP 1 and lay on ground as shown.

Orient (2) insert nuts on RIGHT SUPPORT (H) to align with (2) holes on SEAT (A). Insert (2) SCREWS (K), from inside, through SEAT (A) and hand fasten to RIGHT SUPPORT (H). Then with HEX KEY (L) tighten (2) SCREWS (K).

Orient (3) insert nuts on RIGHT FRONT LEG (F) to align with (3) holes on SEAT (A). Insert (3) SCREWS (K), from inside, through SEAT (A) and hand fasten to RIGHT FRONT LEG (F). Then with HEX KEY (L) tighten (3) SCREWS (K).

Put RIGHT ARMREST (D) on RIGHT FRONT LEG (F) and RIGHT SUPPORT (H), making sure holes are aligned with insert nuts. Insert SCREW (K) through RIGHT ARMREST (D) and hand fasten to RIGHT SUPPORT (H). Insert SCREW (K) through RIGHT ARMREST (D) and hand fasten to RIGHT FRONT LEG (F). Finally tighten both SCREWS (K) with HEX KEY (L).

Seat Assembly after STEP 2

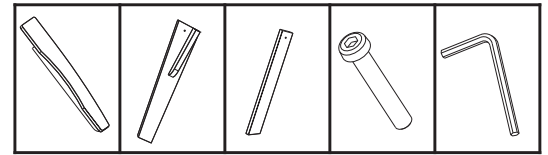
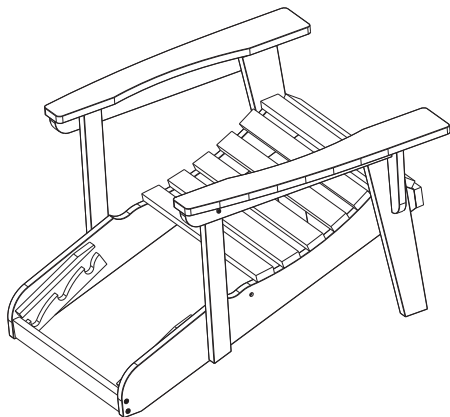

D(1) F(1) H(1) K(7) L(1)

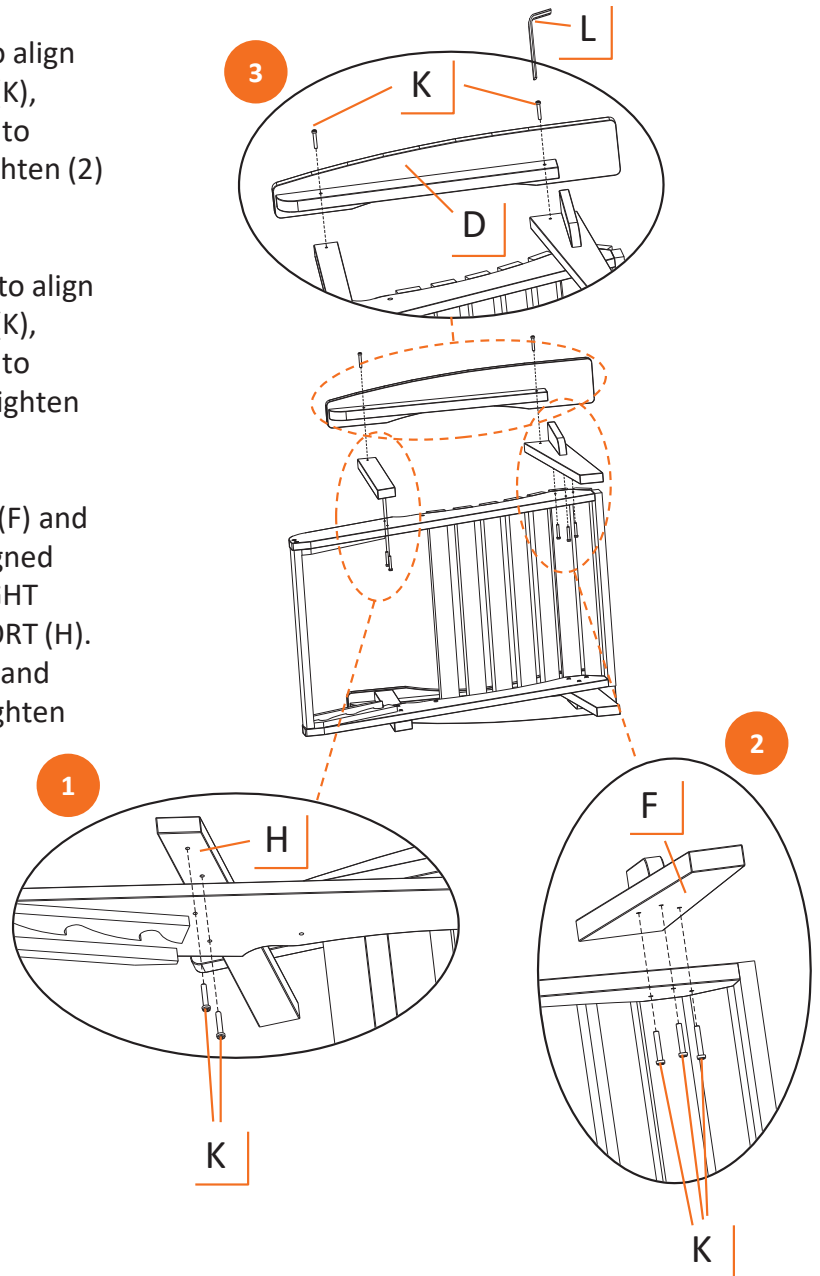

# ASSEMBLY INSTRUCTIONS

## STEP 3

With 2 people, carefully hold BACKREST (B) over Seat Assembly. Slide Back Support into notches on each side of SEAT (A).

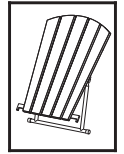

B (1)

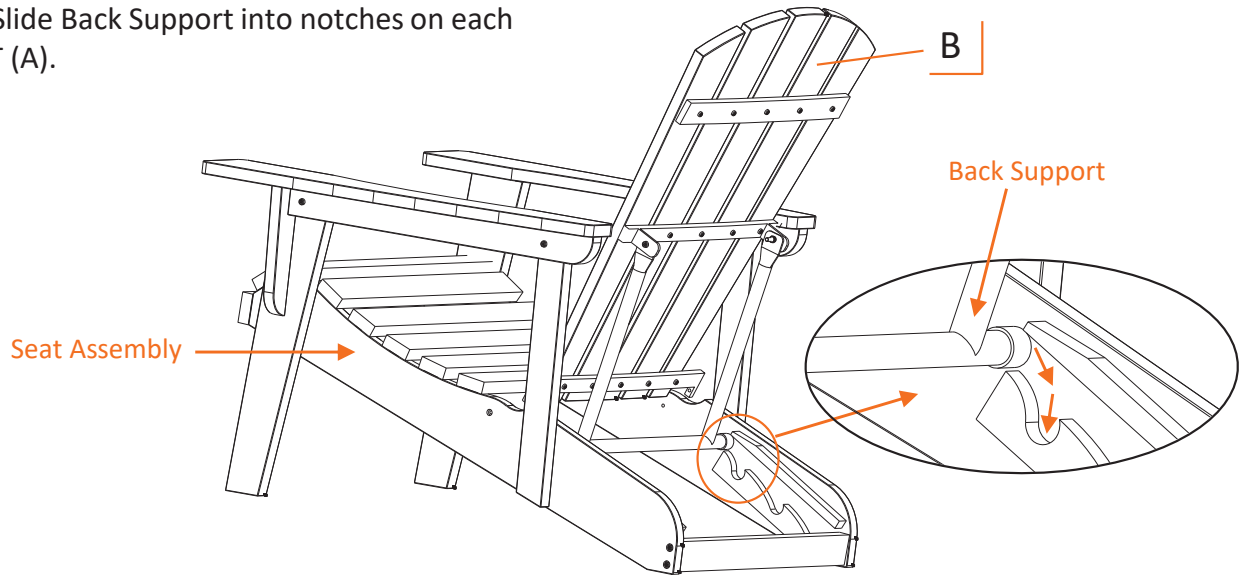

## STEP 4

On left side, insert SCREW (K) through SEAT (A), BACKREST (B) and WASHER (J). With WRENCH (M) holding NUT (I) in place, tighten SCREW (K) onto NUT (I) with HEX KEY (L).

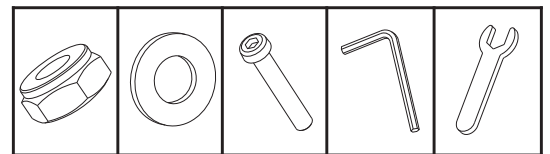

I (2)

J (2)

K (2)

L (1)

M (1)

Repeat for right side.

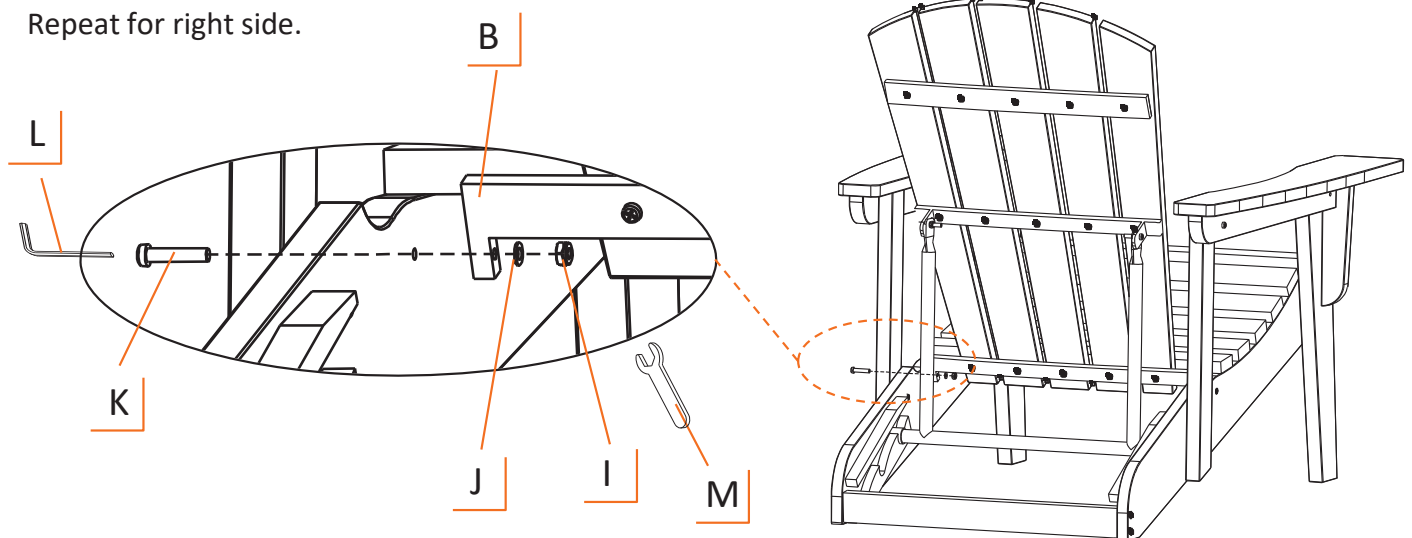

# USAGE INSTRUCTIONS

## ADJUST SEAT BACK RECLINE POSITIONS

There are 3 reclining positions. Lift BACKREST (B) and move Back Support to position you desire.

POSITION 1

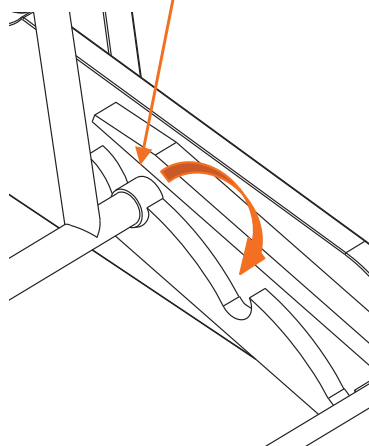
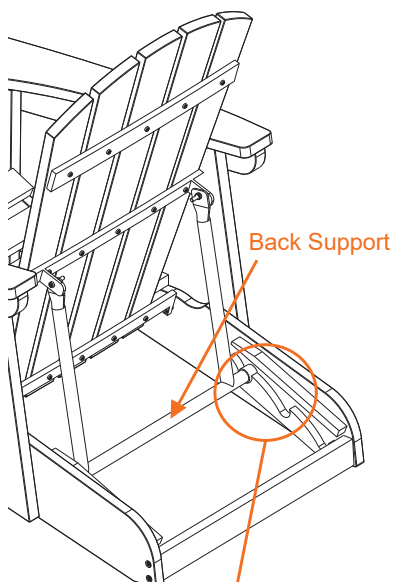

POSITION 2

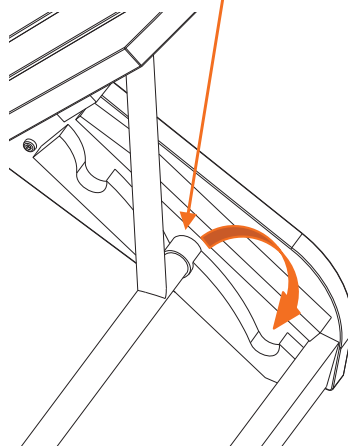
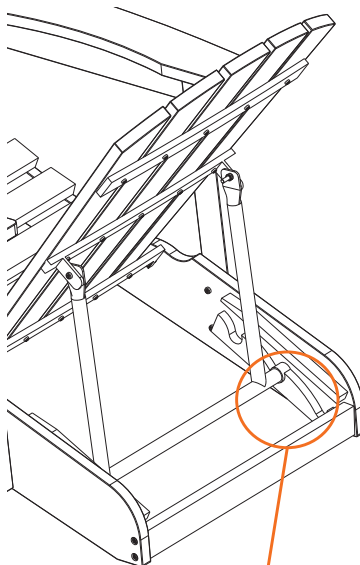

POSITION 3

