

Installation & Assembly

Version:1.0

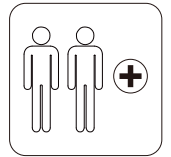
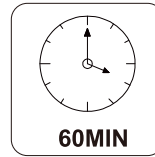
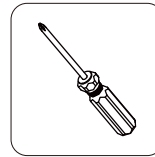
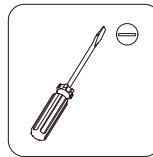
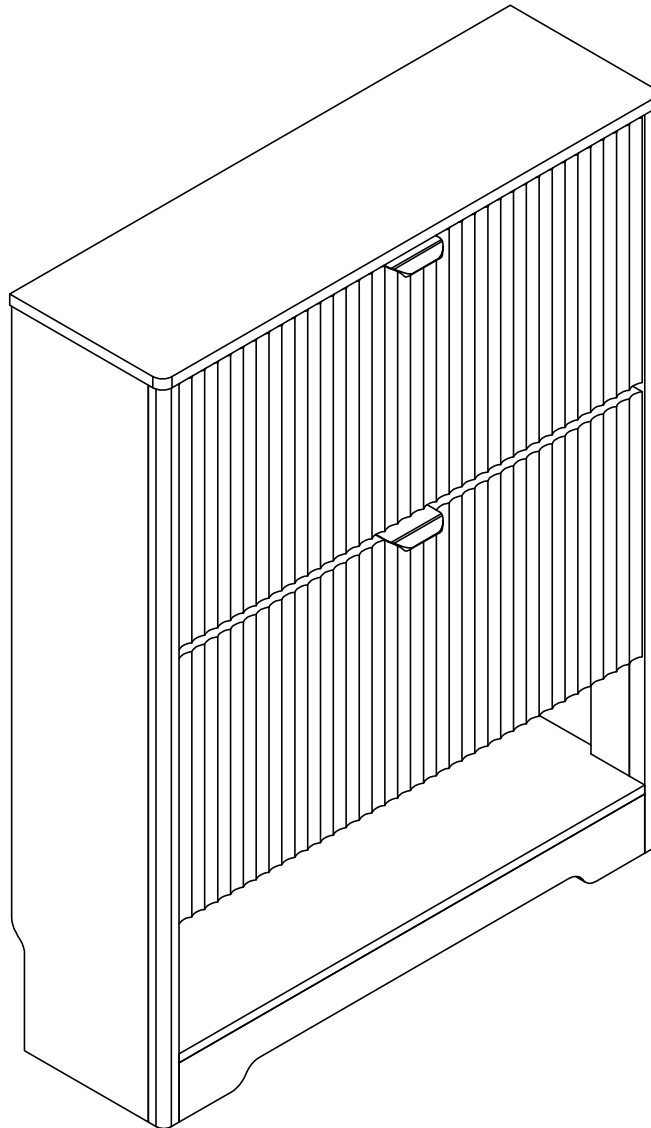

EN_IMPORTANT, RETAIN FOR FUTURE REFERENCE: READ CAREFULLY.

USING CAM LOCK AND QUICKFIT

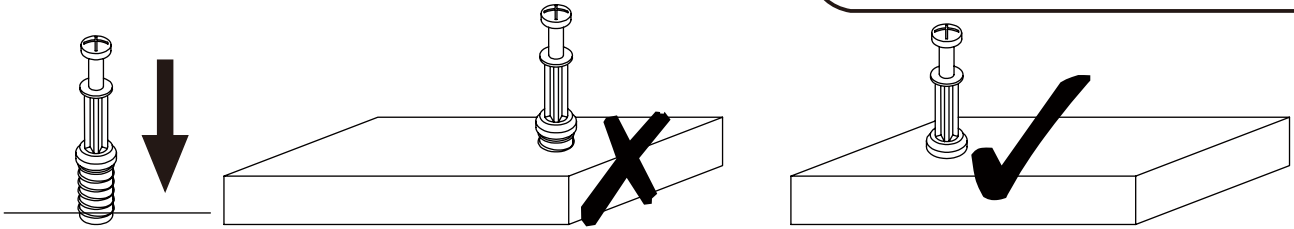

EN_QUICKFIT: Tighten quickfit until shoulder is flush with panel. Do not overtighten or undertighten.

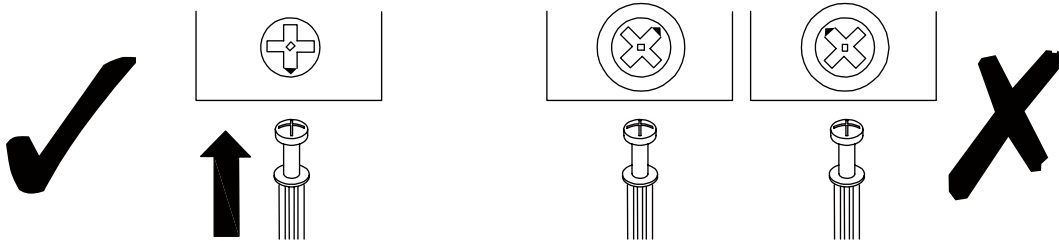

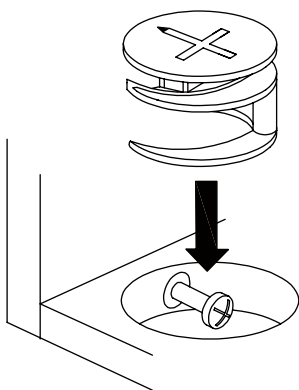

EN_CAM LOCK: When fitting cam lock, ensure starting position is correct before you insert connecting quickfit.



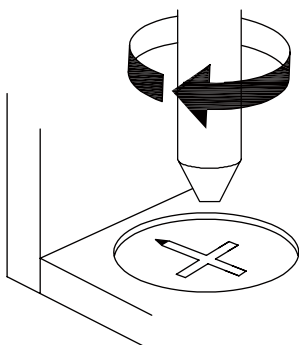



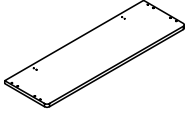
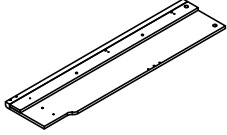
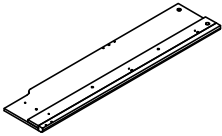
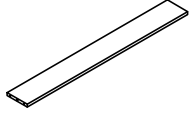
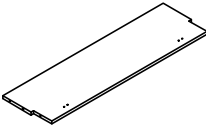
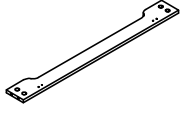
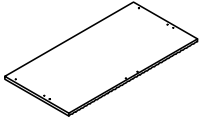
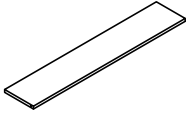
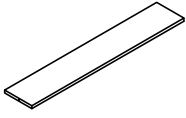



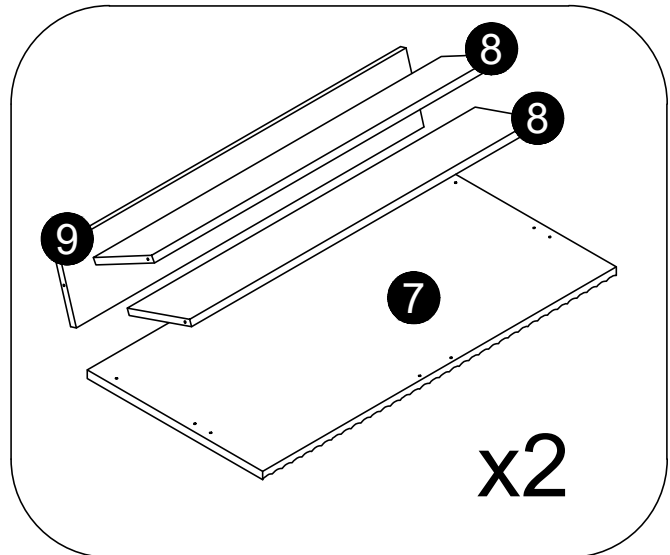
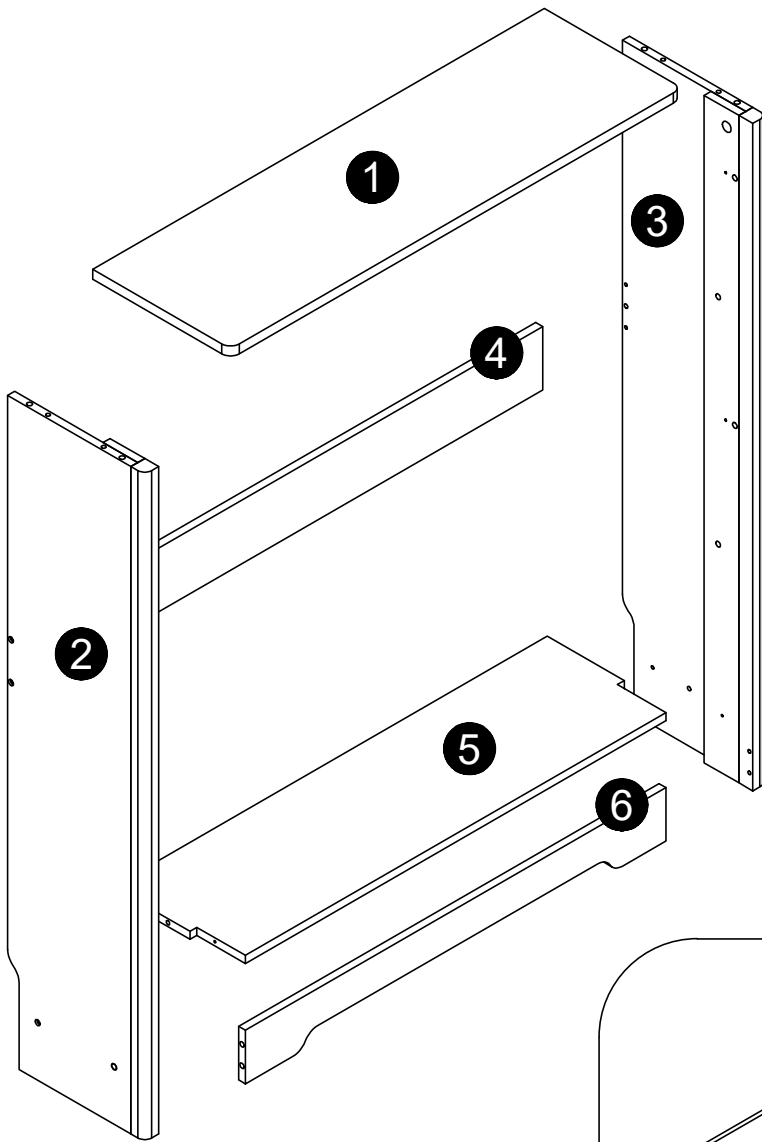

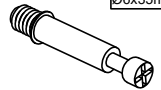
EN_Quickfit head should be in the centre of the cam lock when the two panels are joined.
Cam lock should be inserted before quickfit.

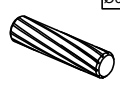
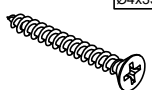

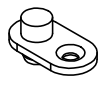

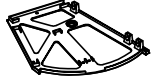
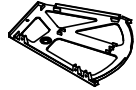
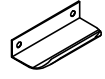
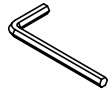
EN_Turn cam lock clockwise to tighten.

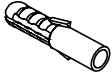
NO.	PARTS	QTY	SPARE
①		x1	
②		x1	
③		x1	
④		x1	
⑤		x1	
⑥		x1	
⑦		x2	
⑧		x4	
⑨		x2	
	 Hardware Kit	x1	

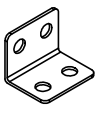
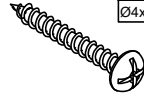

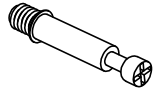
<p>A x8 ∅6x35mm</p> 	<p>B x8 ∅15x10mm</p> 	<p>C x8 ∅6x30mm</p> 	<p>D x6 ∅4x35mm</p> 	<p>E x40 ∅3.5x12mm +4 (spare)</p> 	<p>F x4</p> 
<p>G x4</p> 	<p>H x4</p> 	<p>I x2</p> 	<p>J x2</p> 	<p>K x2</p> 	<p>L x1</p> 
<p>M x2 M-1 M-2</p> 	<p>N x2</p> 	<p>O x8</p> 	<p>P x2</p> 	<p>Q x4 ∅4x50mm</p> 	

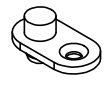
<p>A x4</p> 	<p>E x4</p> 	<p>F x4</p> 
--	--	--

01

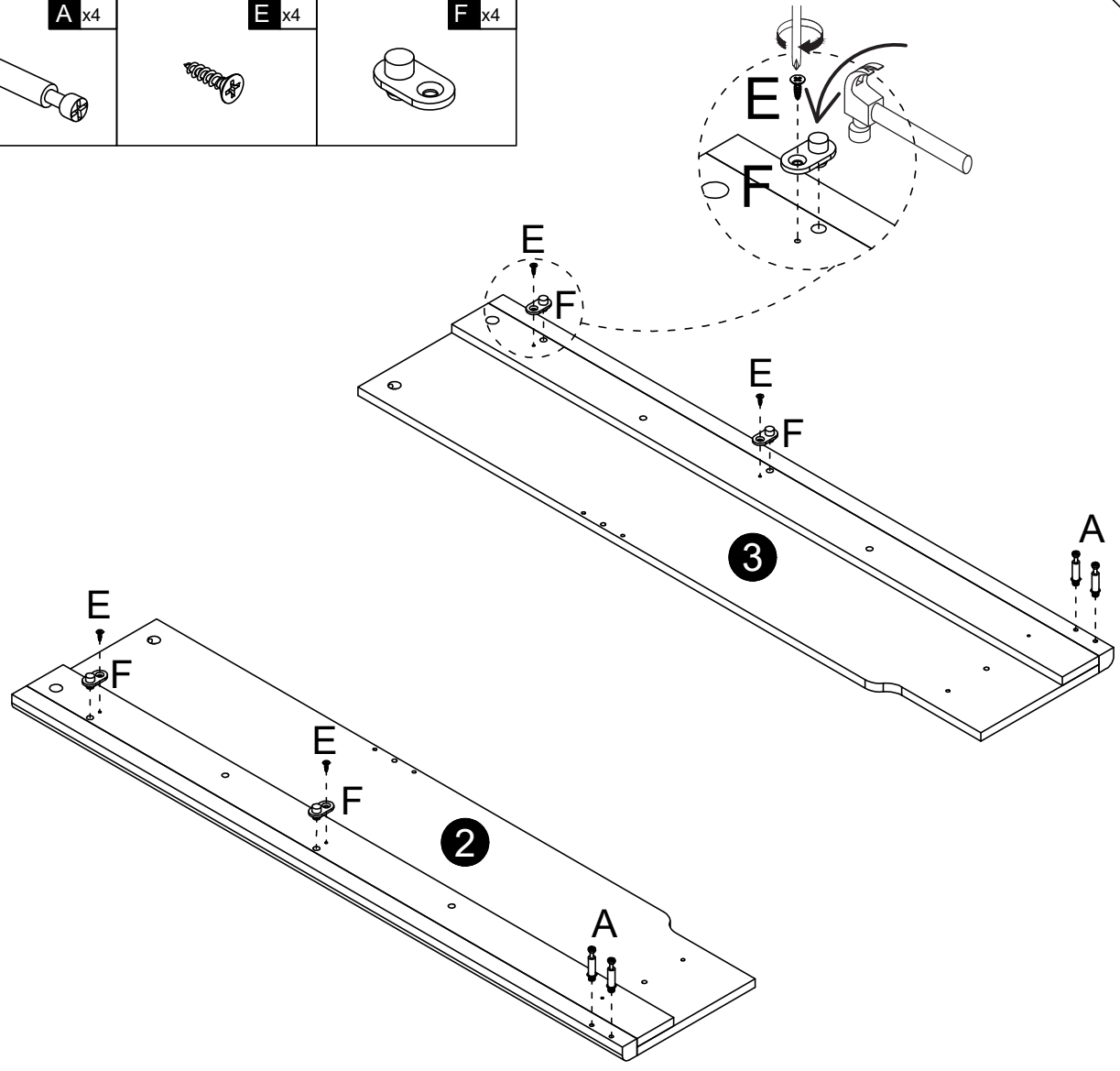

E x8

P x2

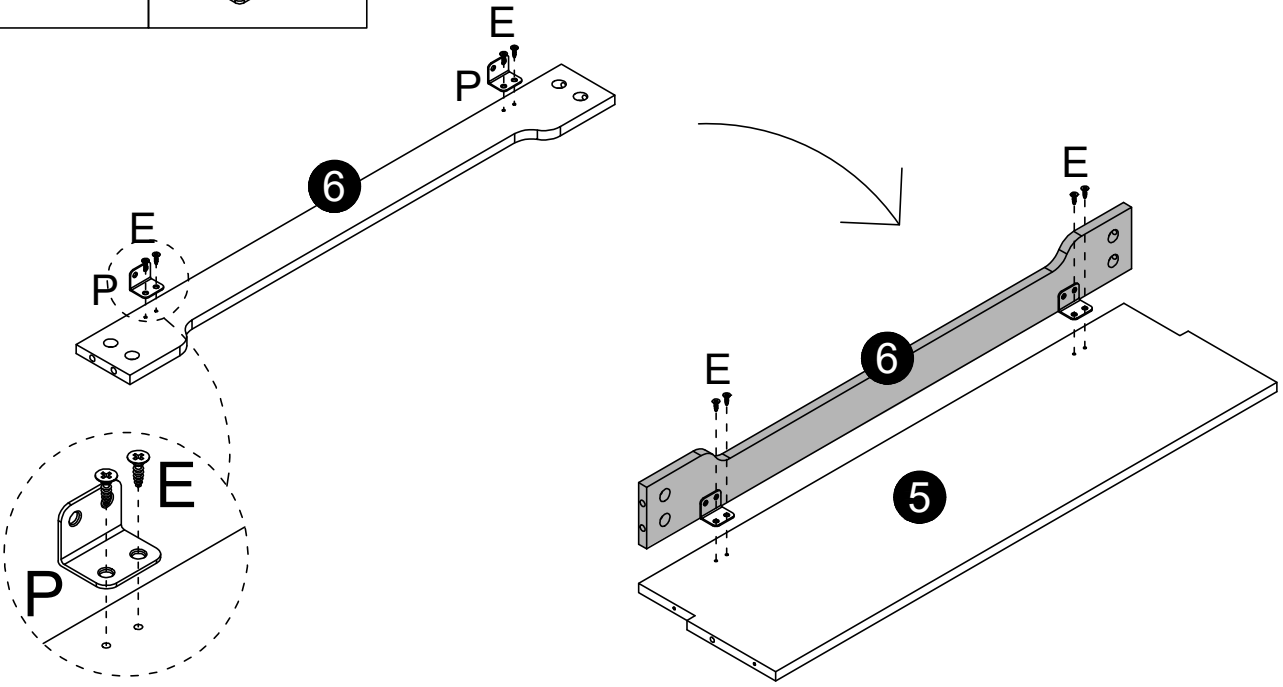
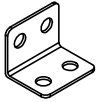

B x2

C x2

D x2

Q x2

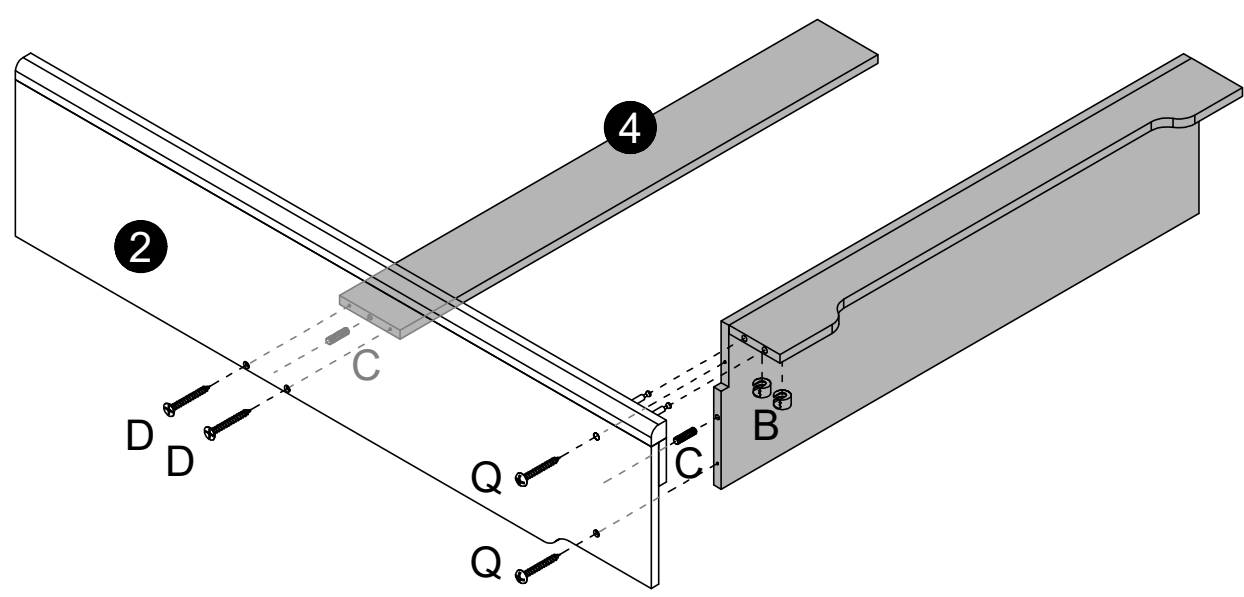
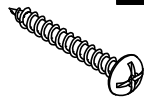
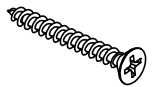

B x2



C x2



D x2

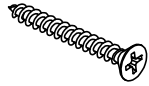

Q x2

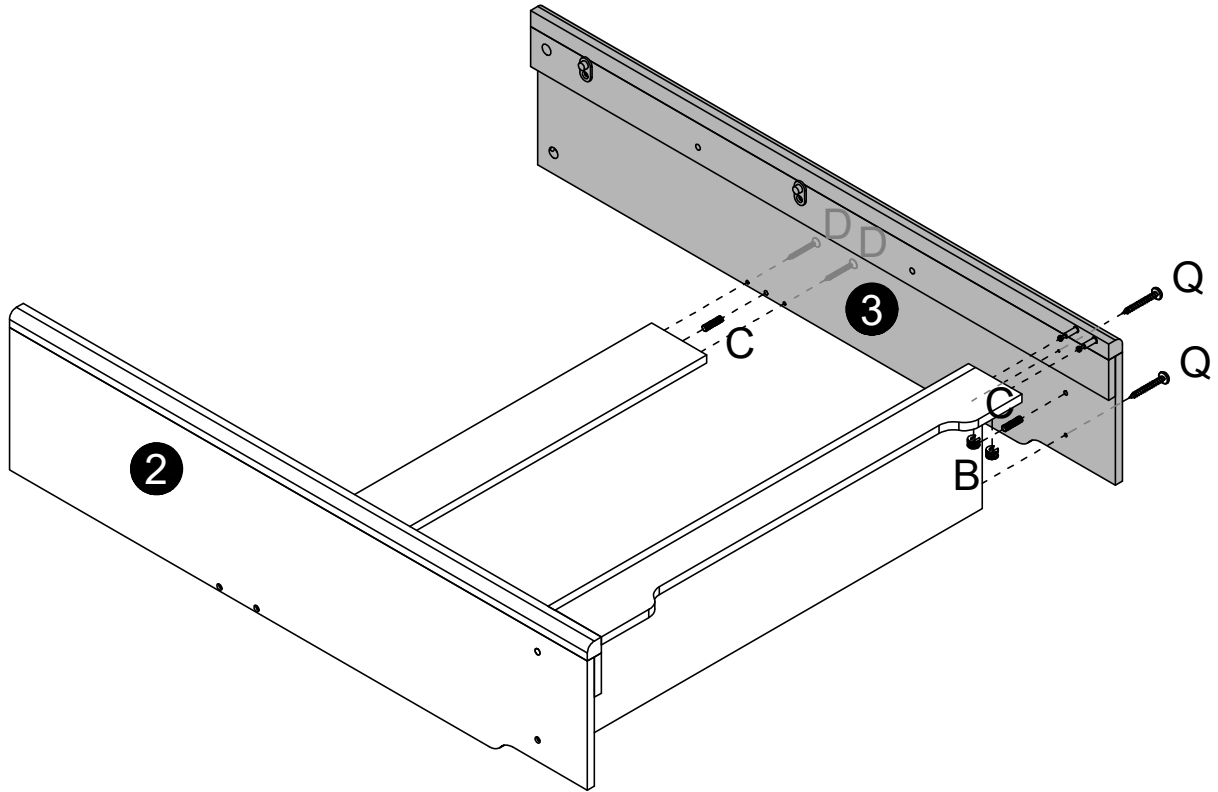
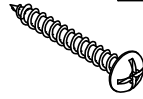

A x4

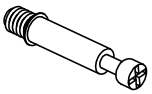

M x2

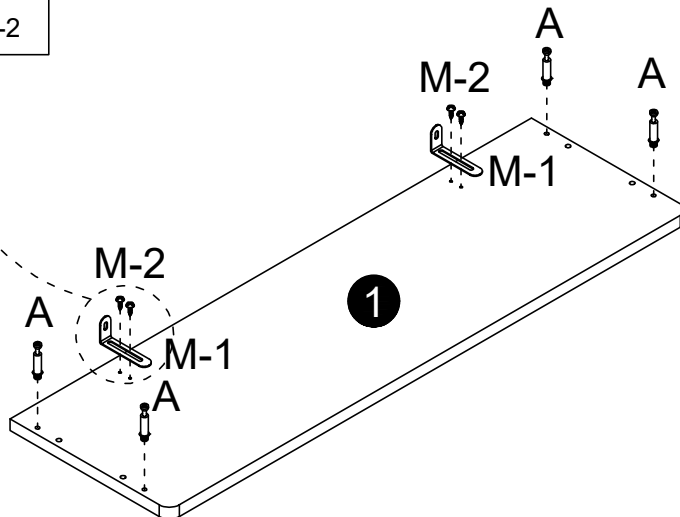
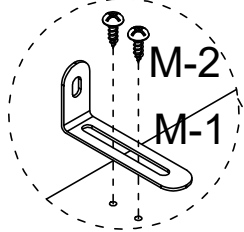
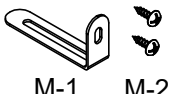

B x4



C x4

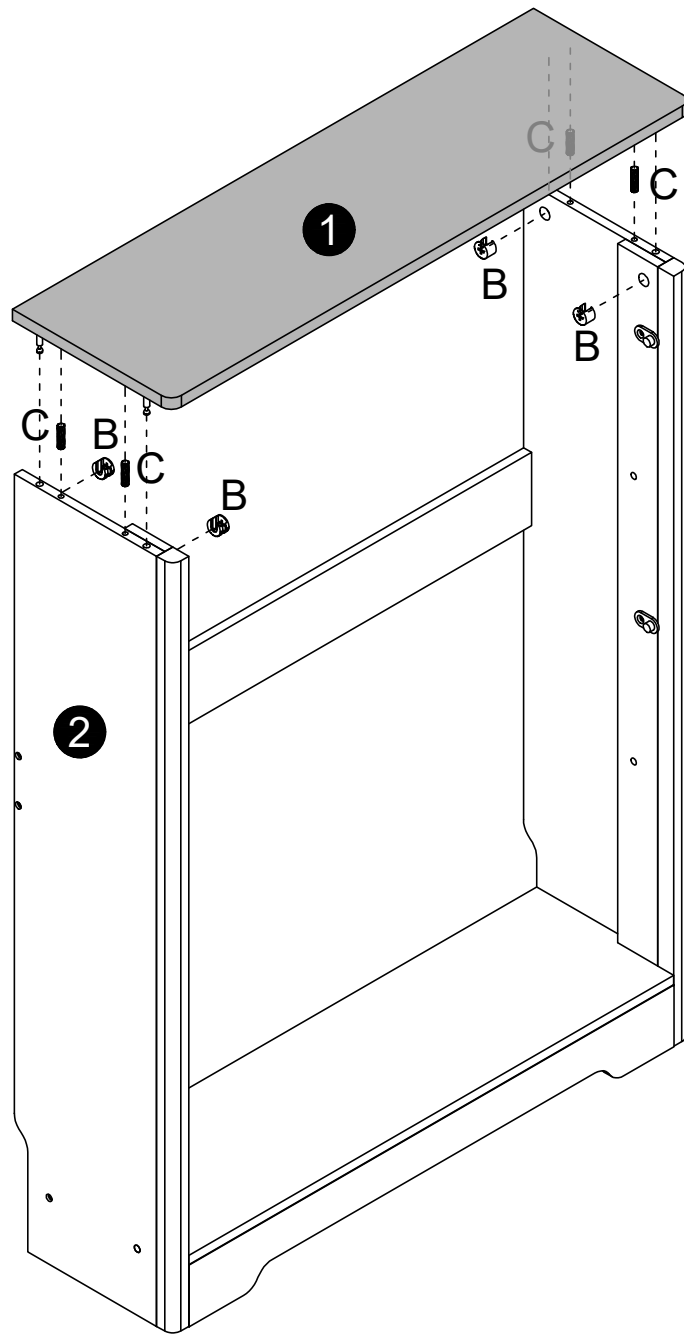
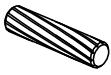

D x2

N x2

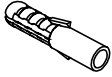
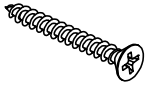

WALL

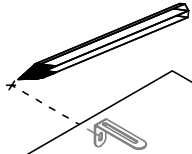

(1)x2

First, use a ruler to measure the approximate height of the product on the wall, and then mark it with a pen.

WALL

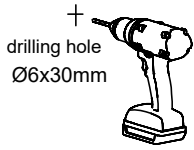

(2)x2

Then use a tape drill to make holes in the wall that are suitable for the product screws.

WALL

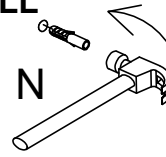

(3)x2

Then, put the expansion bolt into the hole

WALL

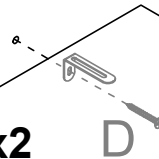

(4)x2

Finally, pass the matching screws through the "anti-rewind" and tighten them to fix them on the wall.

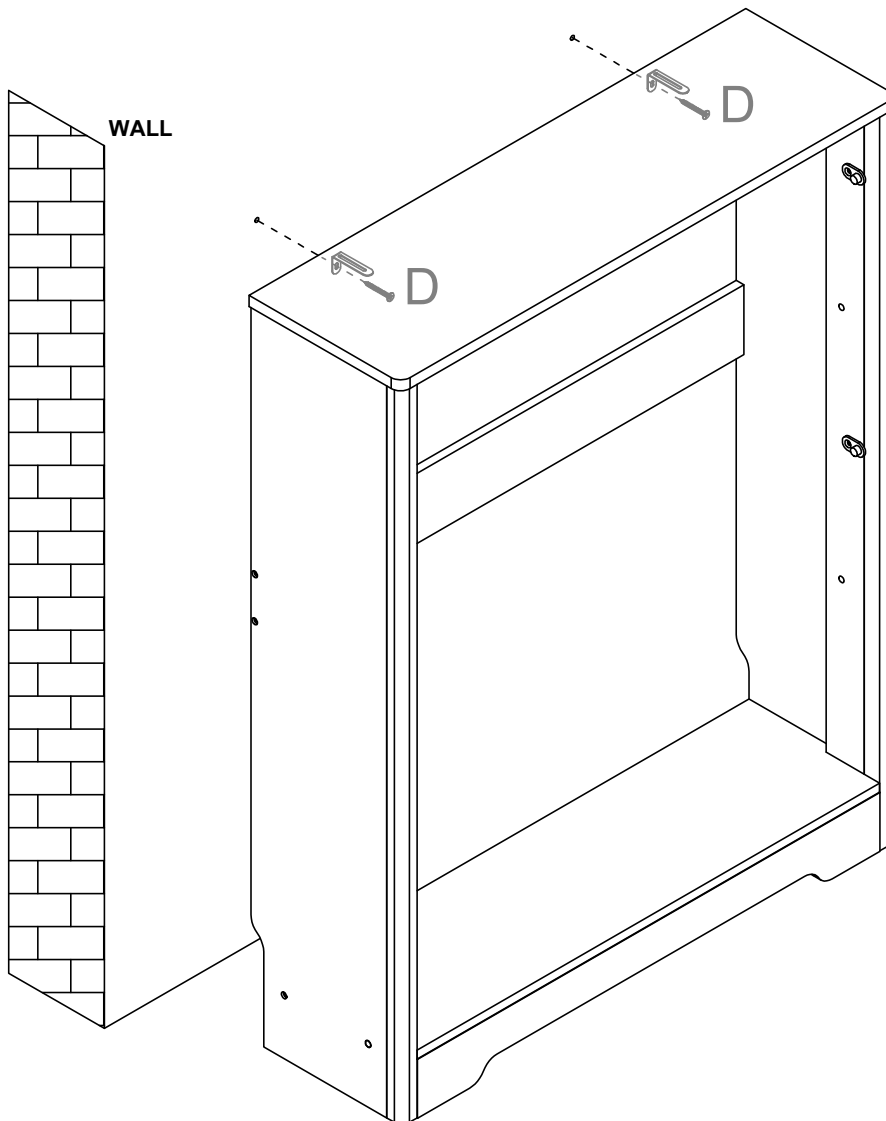

E x24



I x2

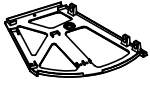

J x2

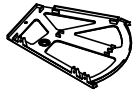

K x2

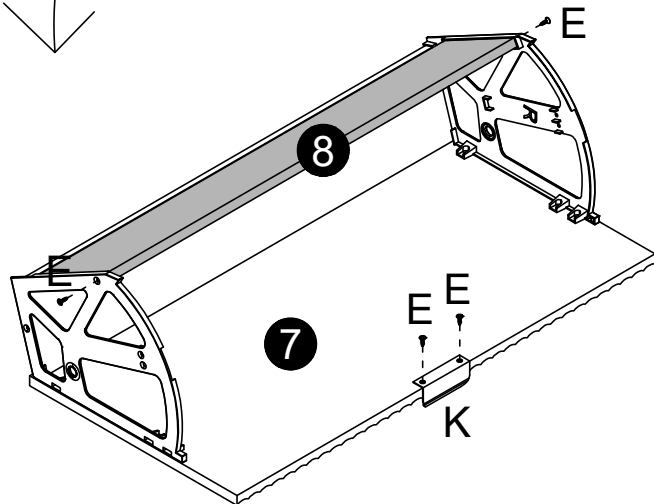
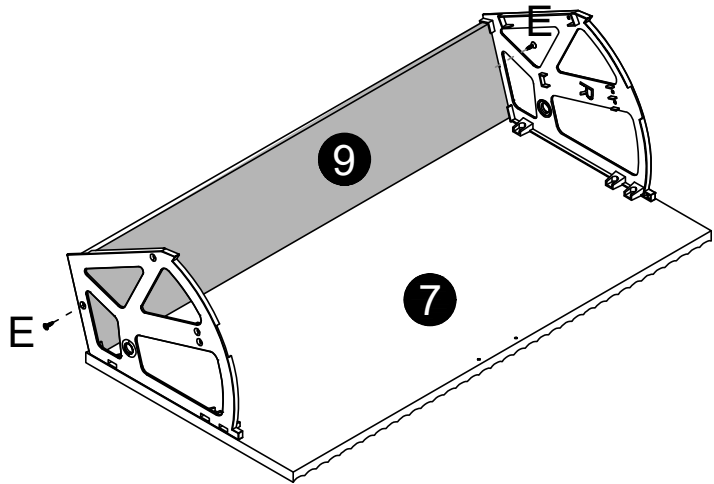
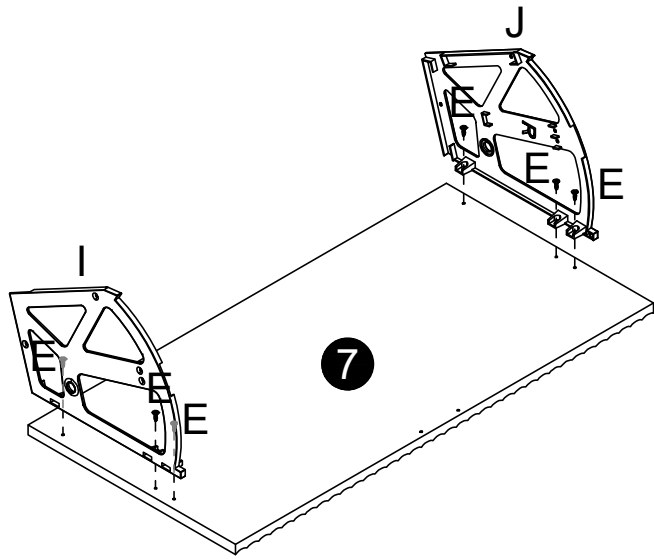

x2

G x4

H x4

L x1

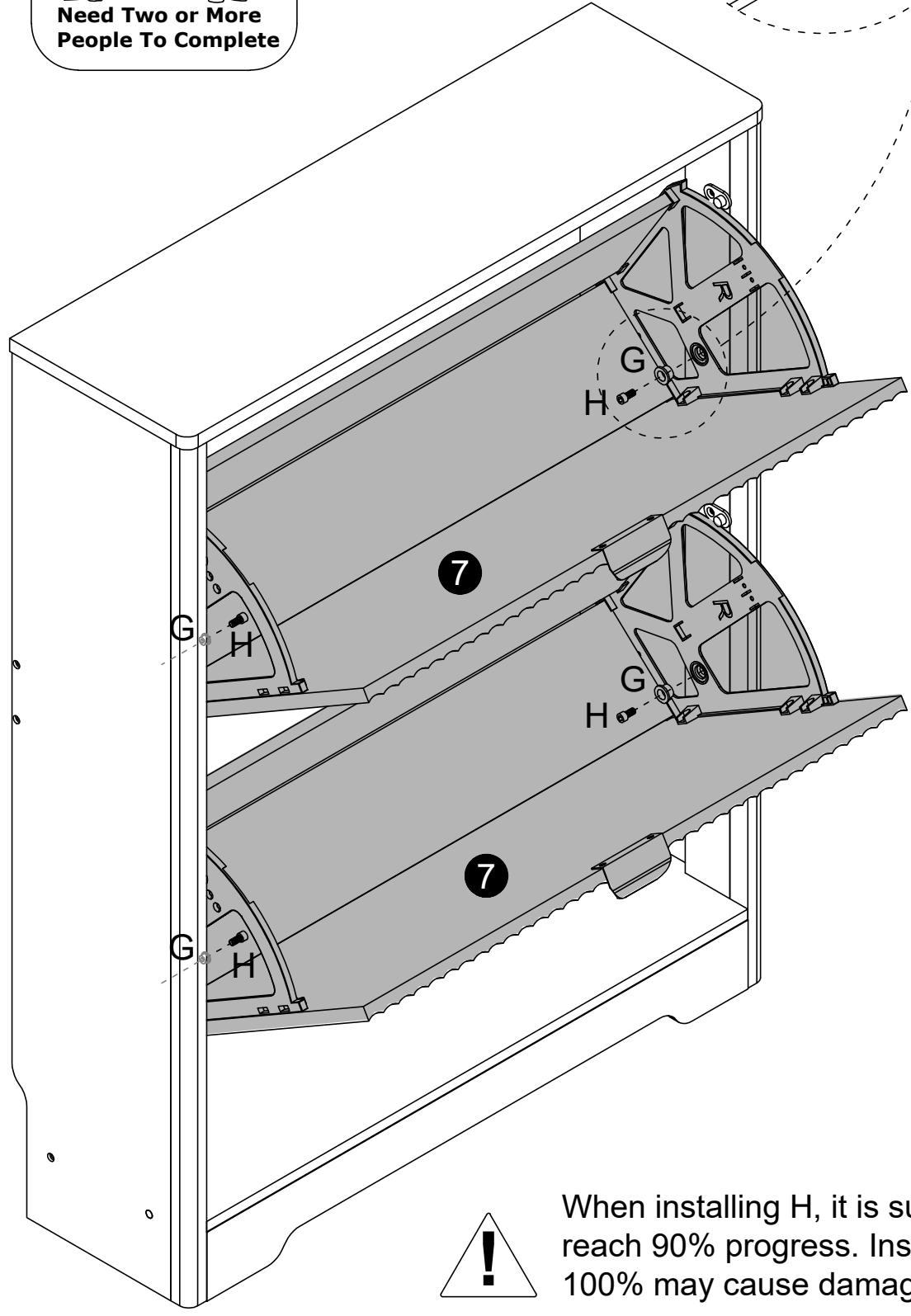
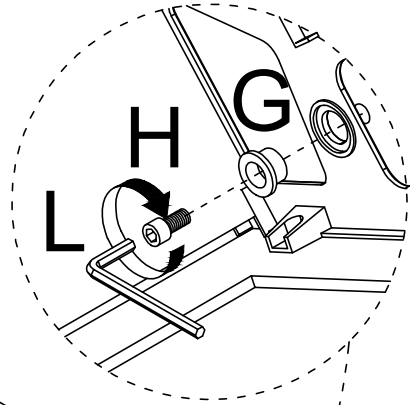
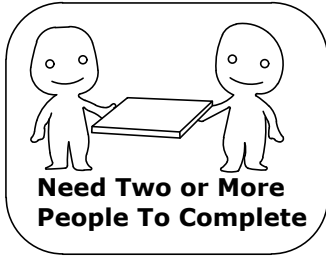
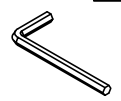

When installing H, it is sufficient to reach 90% progress. Installing 100% may cause damage to G.

E x4

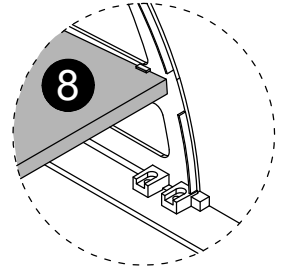
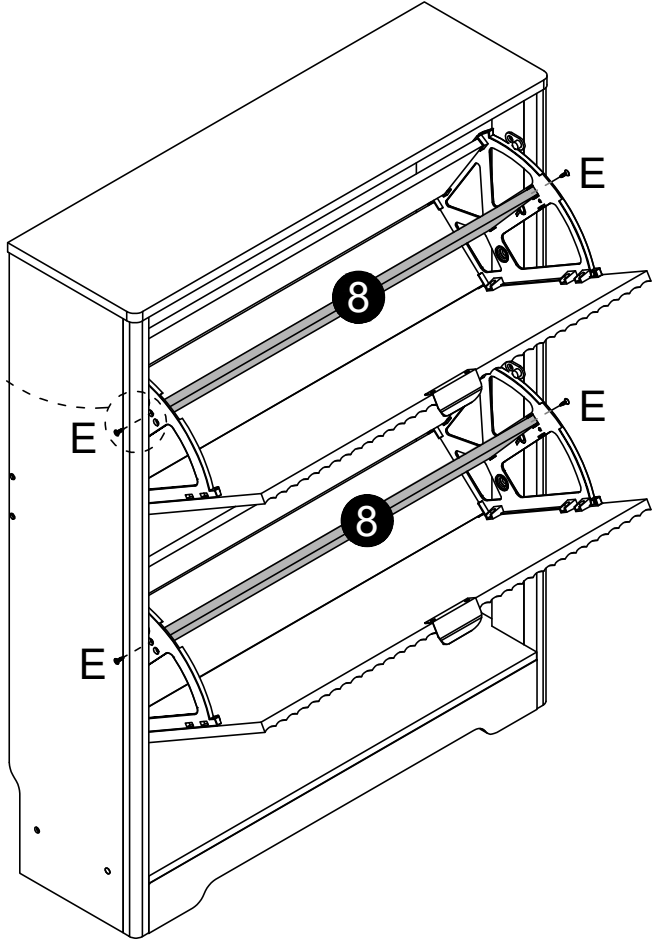
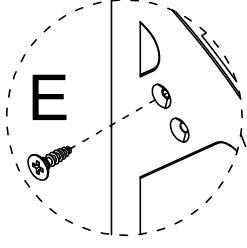

OR

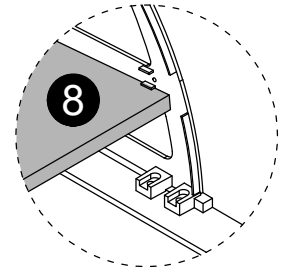

O x8

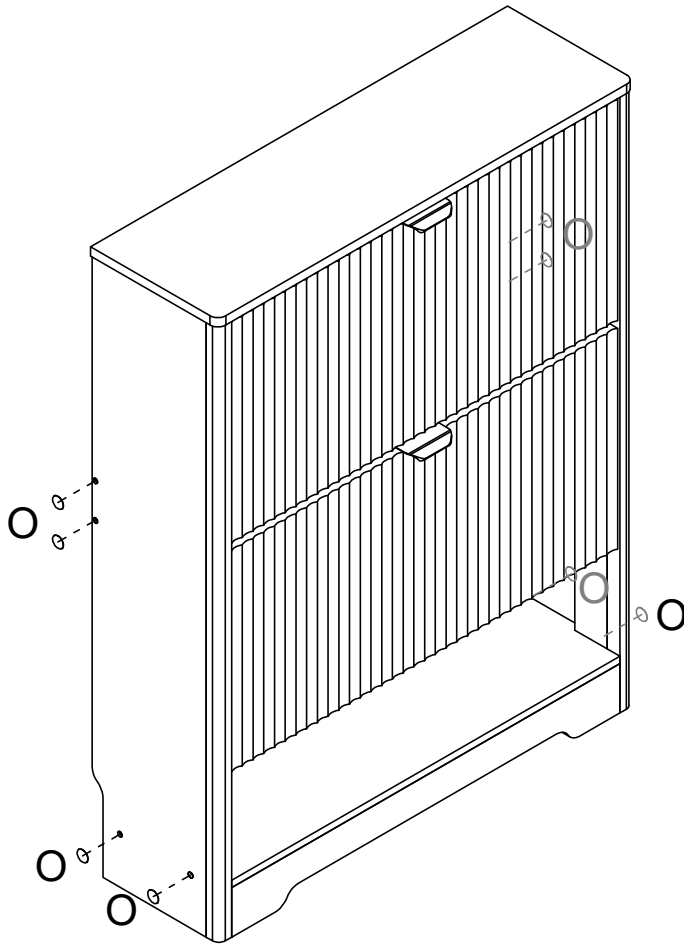

Done