

Farmhouse Kitchen Island

HE-NCFCFD_V1.0

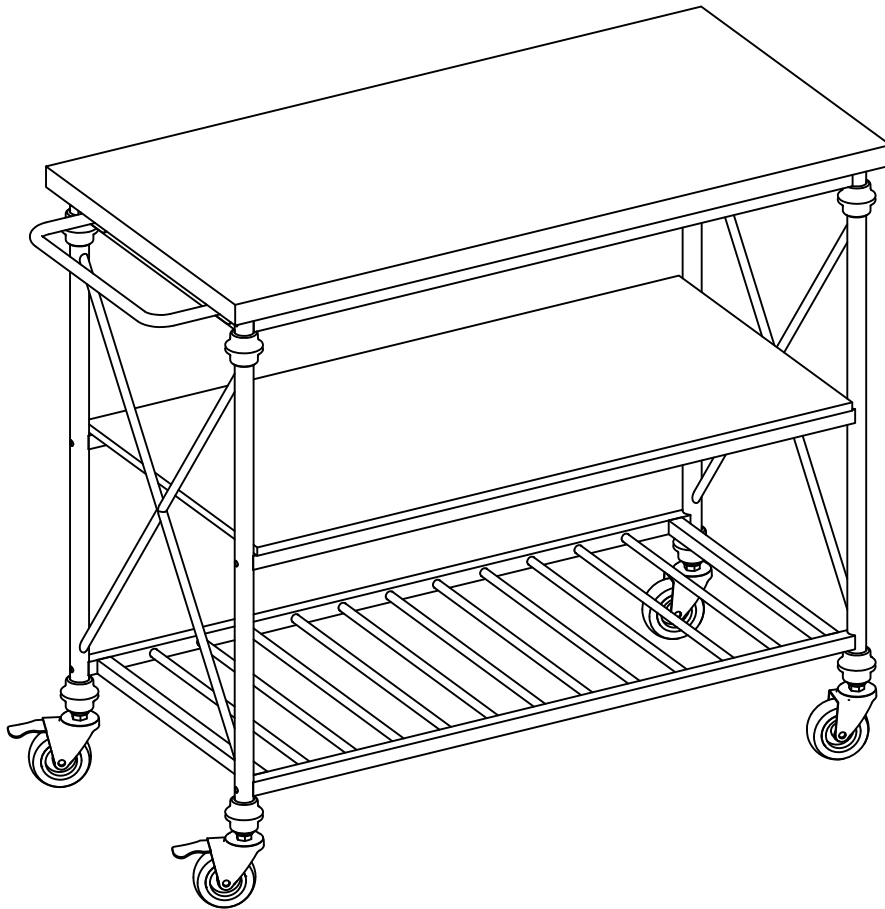

Assembly Manual

Please call for replacement parts or assistance: 1-478-666-6611. Mon-Fri 9am-5pm (PST)
Thank you for your purchase at our store.

Please contact us directly if you have difficulty with assembly or need replacement parts.
Professional customer service is here to assist you.

Email: emarthome@hotmail.com

Please call for replacement parts or assistance: 1-478-666-6611. Mon-Fri 9am-5pm (PST)
Please attach your order ID or some photos related so that we could help you better.

Two people are recommended to install, which will greatly improve your installation efficiency.

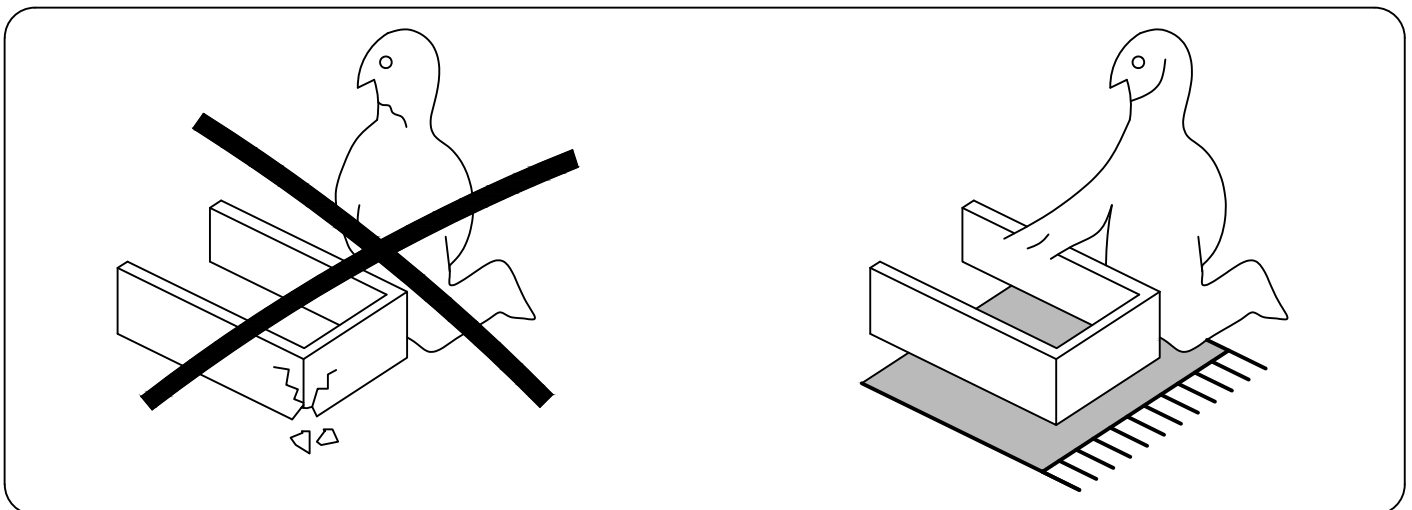

Tips Before Assembly

1. Read through each step carefully and follow the proper order.
2. Identify, sort and count all the parts with tags.
3. To avoid any scratching, putting a soft blanket on the floor is suggested.
4. If using a power drill or power screwdriver for the screwing, please be aware to slow down and stop when screw is tight. Failure to do so may result in stripping the screw.
5. Put the screws in loosely until all pieces are together and then tighten them all. It will save your time if you make a mistake while installing.

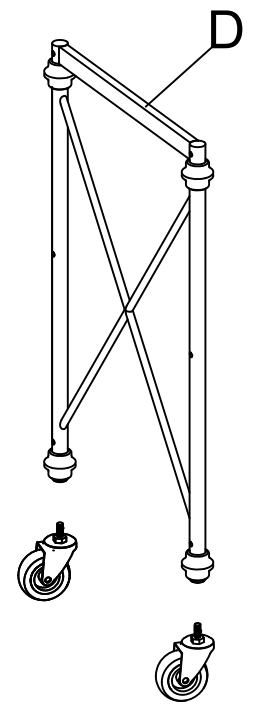
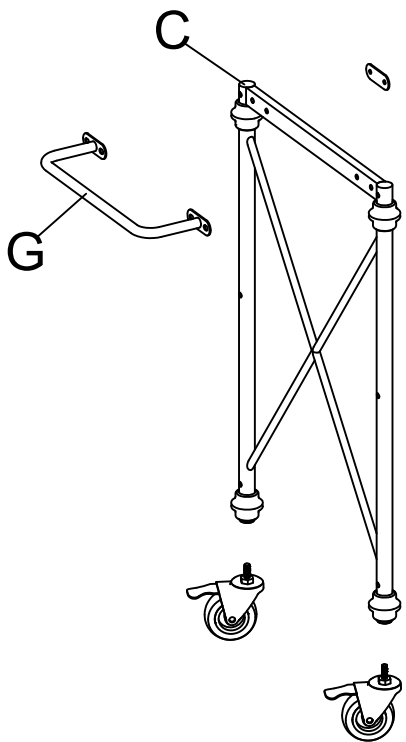
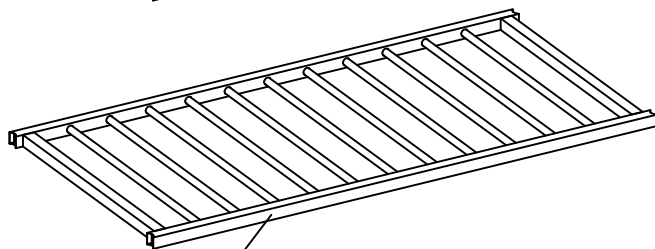
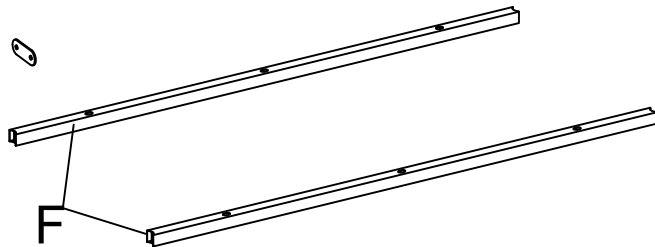
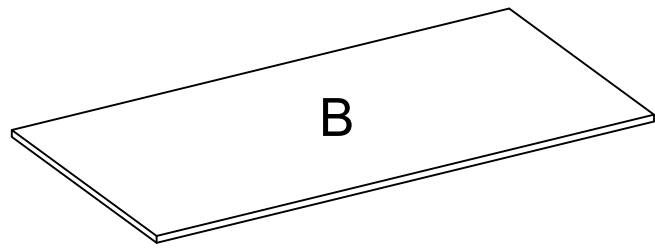
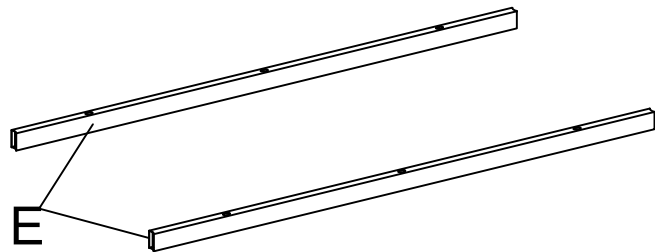
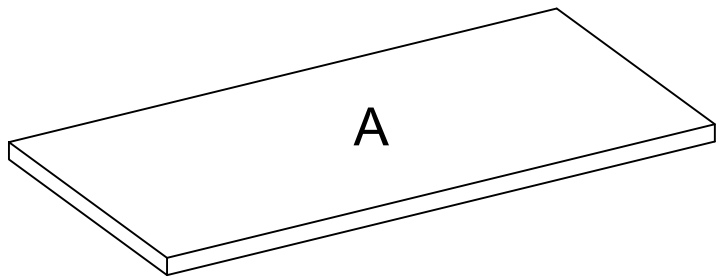



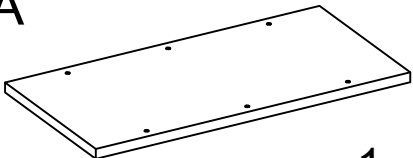
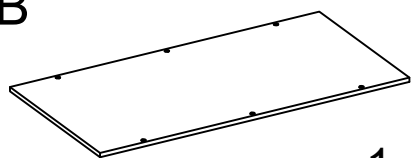
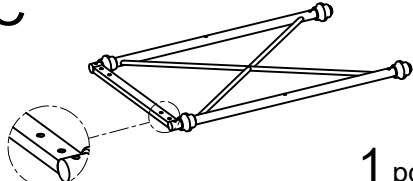
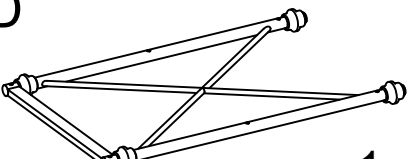
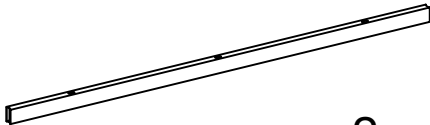
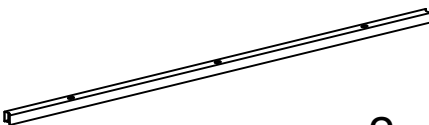

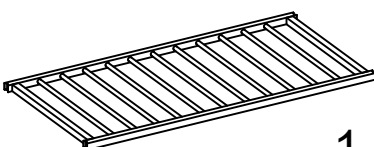



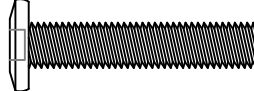

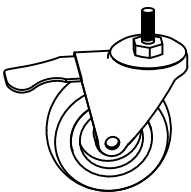
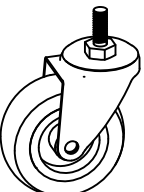

PART LIST

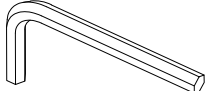
<p>A</p>  <p style="text-align: right;">1 pc</p>	<p>B</p>  <p style="text-align: right;">1 pc</p>	<p>C</p>  <p style="text-align: right;">1 pc</p>
<p>D</p>  <p style="text-align: right;">1 pc</p>	<p>E</p>  <p style="text-align: right;">2 pcs</p>	<p>F</p>  <p style="text-align: right;">2 pcs</p>
<p>G</p>  <p style="text-align: right;">1 pc</p>	<p>H</p>  <p style="text-align: right;">1 pc</p>	

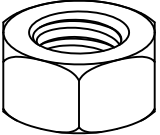
HARDWARE LIST

<p style="text-align: center;">①</p>  <p>M6x27 6 pcs</p>	<p style="text-align: center;">②</p>  <p>M6x30 4 pcs</p>	<p style="text-align: center;">③</p>  <p>M6x40 18 pcs</p>
<p style="text-align: center;">④</p>  <p>M10x20 2 pcs</p>	<p style="text-align: center;">⑤</p>  <p>M10x20 2 pcs</p>	<p style="text-align: center;">⑥</p>  <p>75*25*2.0 2 pcs</p>
<p style="text-align: center;">⑦</p>  <p>16mm 1 pc</p>	<p style="text-align: center;">⑧</p>  <p>10mm 1 pc</p>	<p style="text-align: center;">⑨</p>  <p>4mm 1 pc</p>
<p style="text-align: center;">⑩</p>  <p>∅16*1.0*∅6mm 10 pcs</p>	<p style="text-align: center;">⑪</p>  <p>M6 4 pcs</p>	

STEP 1

①  x6

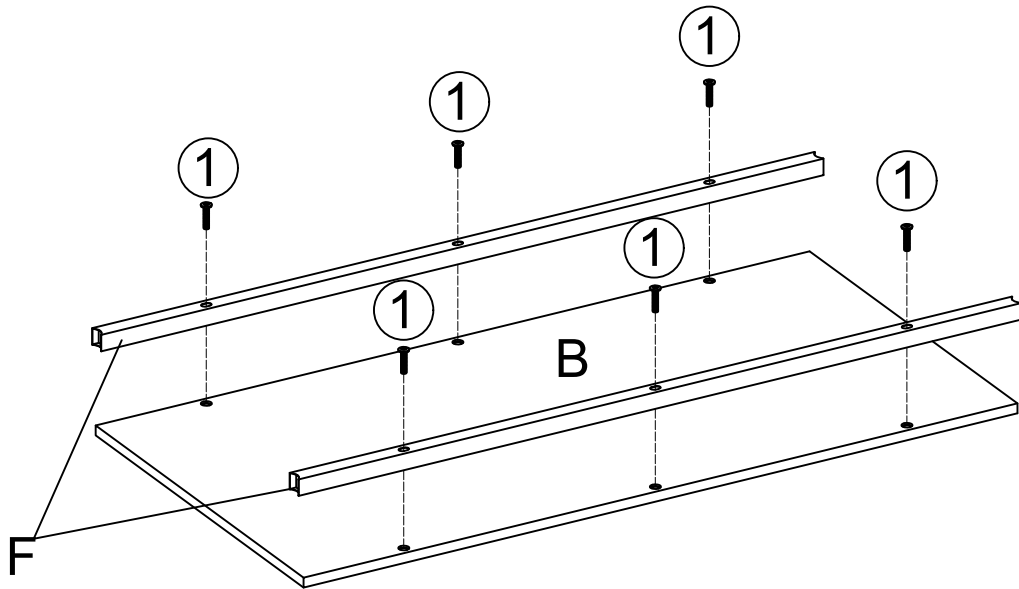

STEP 2

③  x12

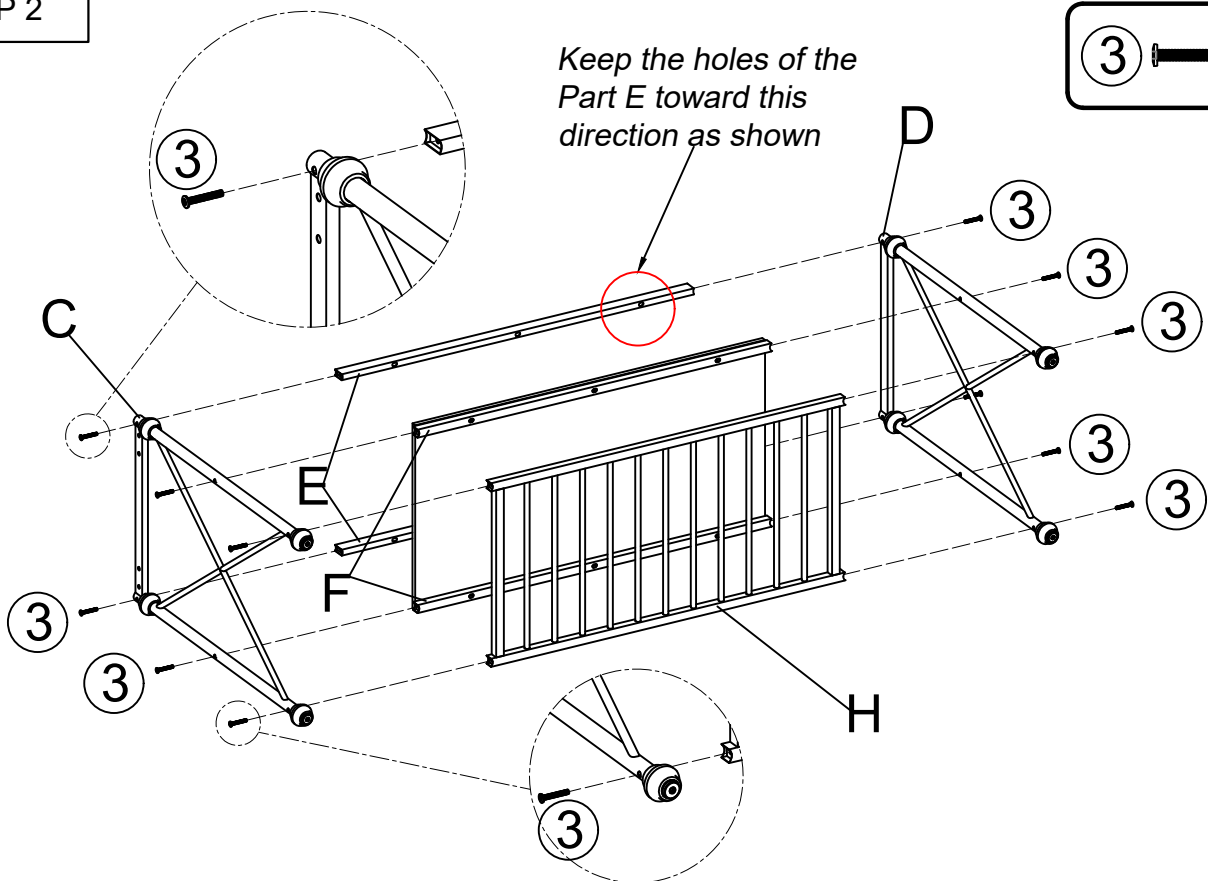

STEP 3

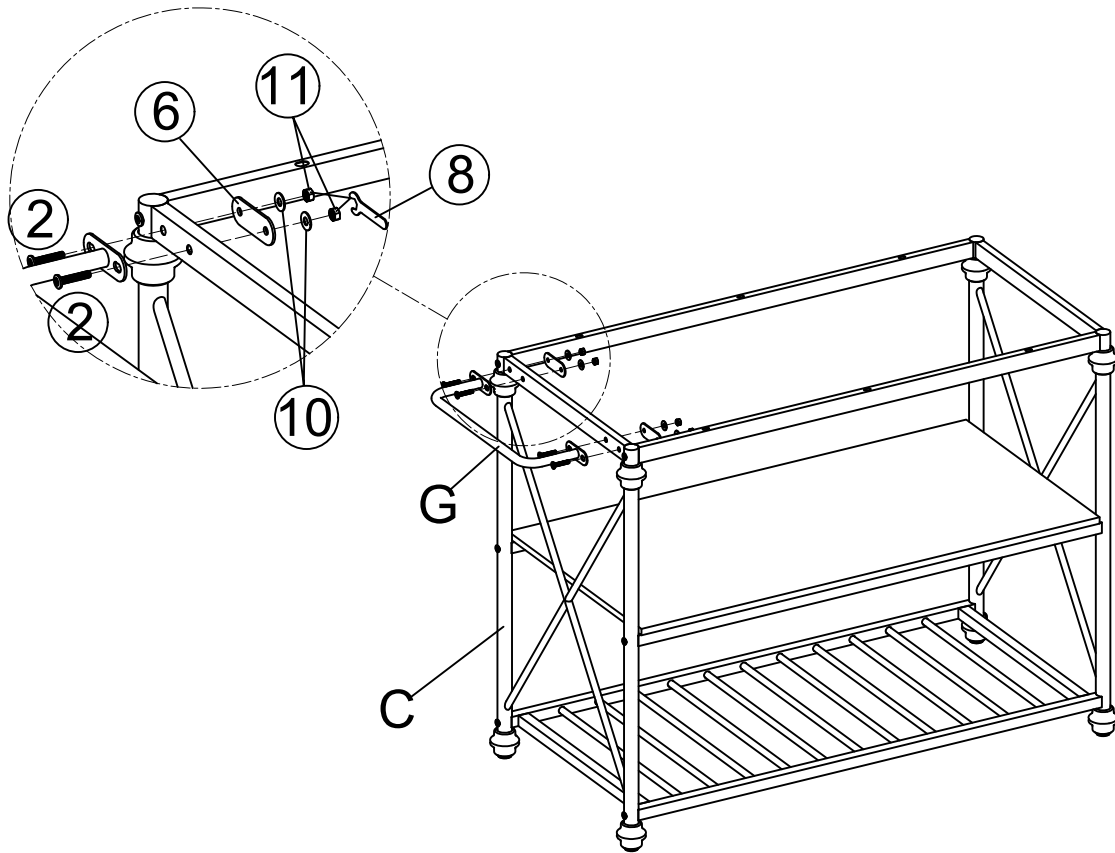

- 2 x4
- 6 x2
- 8 x1
- 10 x4
- 11 x4

STEP 4

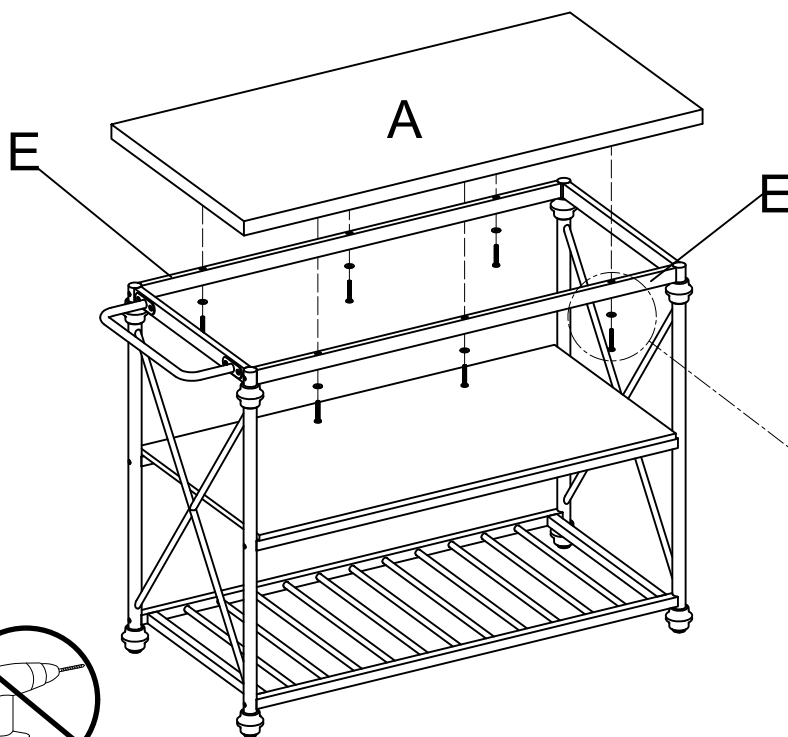



- 3 x6
- 10 x6

The holes of the support bar have flexible space. Don't fully tighten the screws until aligning all of the top panels.



STEP 5

- ④  x2
- ⑤  x2
- ⑦  x1

