

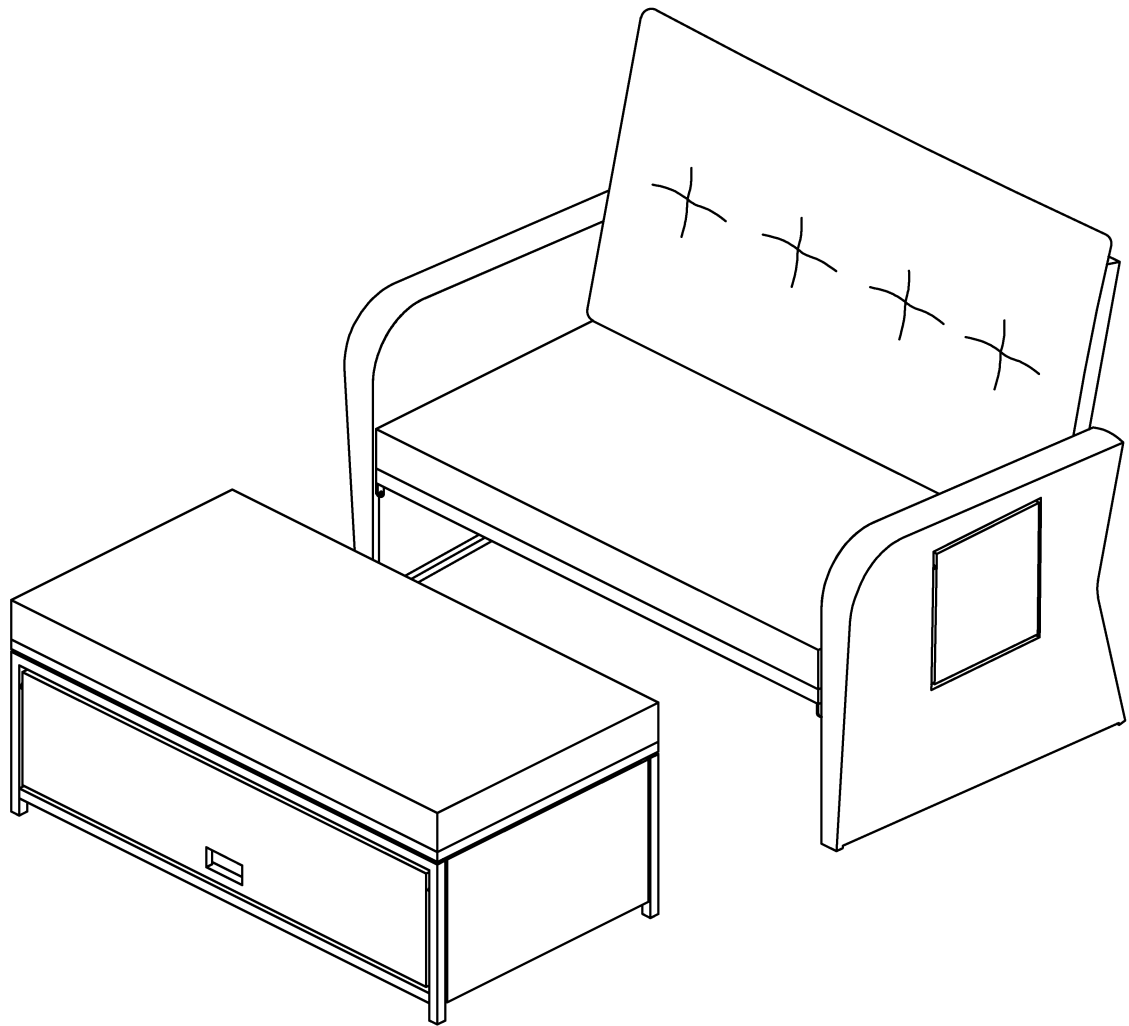

Patio Rattan Daybed

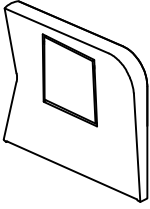
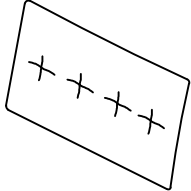
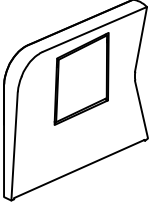
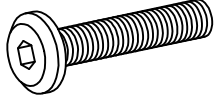
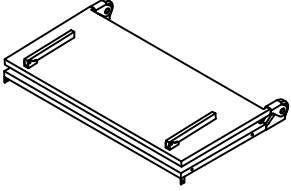
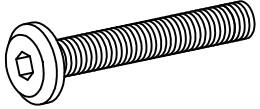
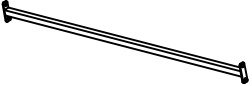
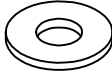
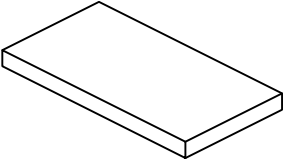

A		1	F		1
B		1	N	 M6*20mm	6
C		1	O	 M6*45mm	4
D		1	P		10
E		1	Q		1

- ① Lay the backrest down on the ground and install the armrest upright. Attach (C) to seat (A) (B) with 4pcs bolts O and 2pc bolts N and 6pcs washers P, using Allen wrench Q

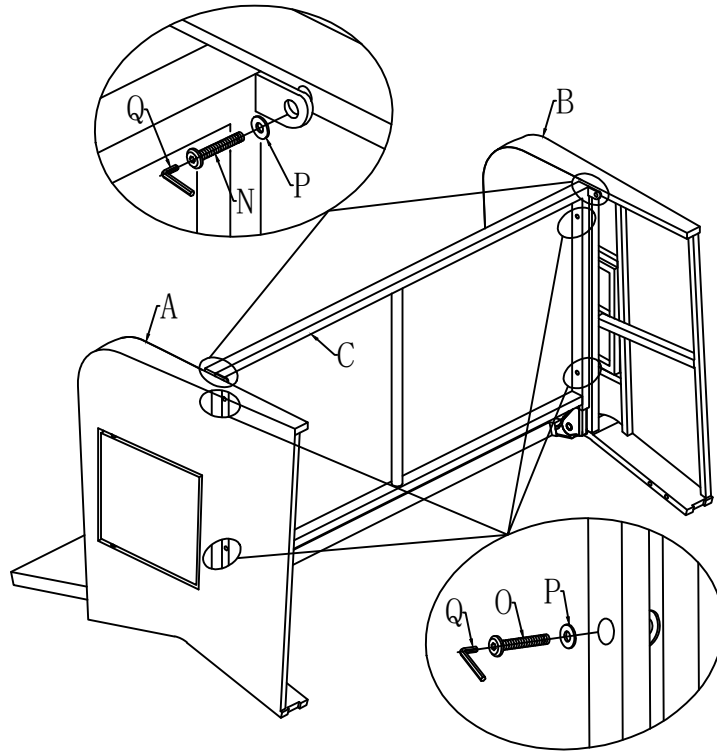

- ② Attach (D) to seat (A) (B) with 4pcs bolts N and 4pcs washers P, using Allen wrench Q

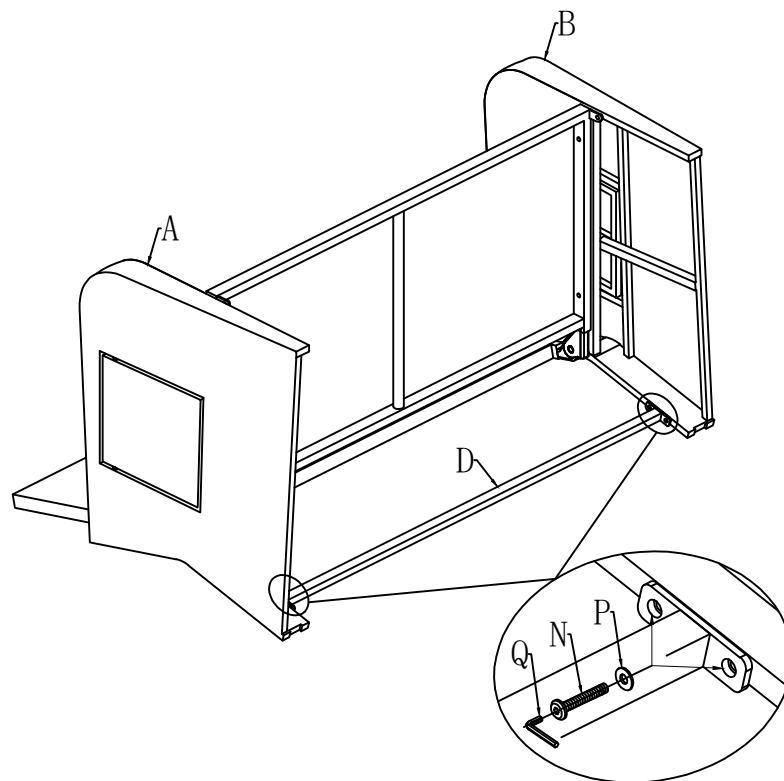

Note: Do not fully tighten any bolts until chair assembly is complete. Failure to follow these instructions may cause the bolt holes to be misaligned during assembly

③ Put cushion (E) (F) onto the seat

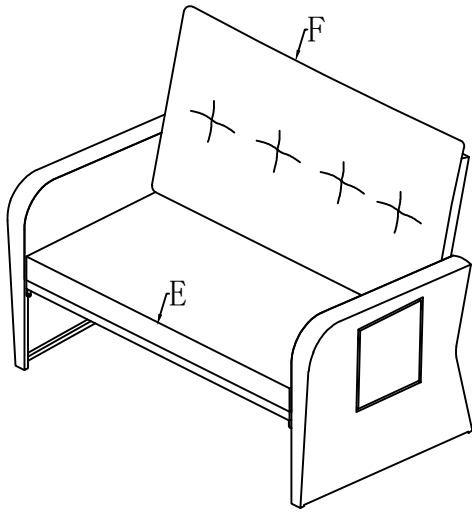

Both sides can be opened

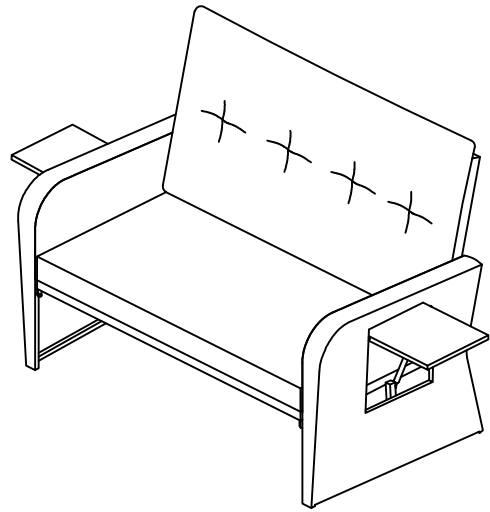

④ Open the foot tube to lay flat on the back

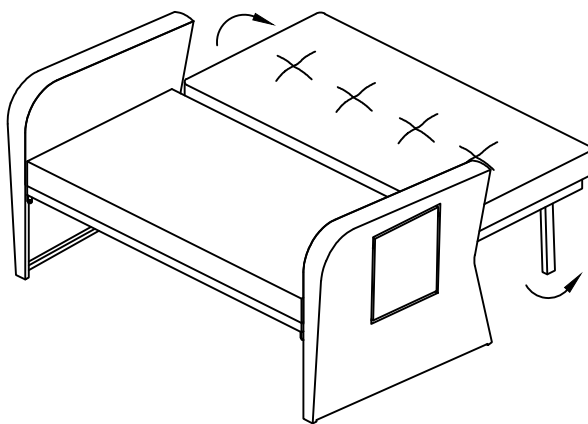

Fold the back and rotate the support tube

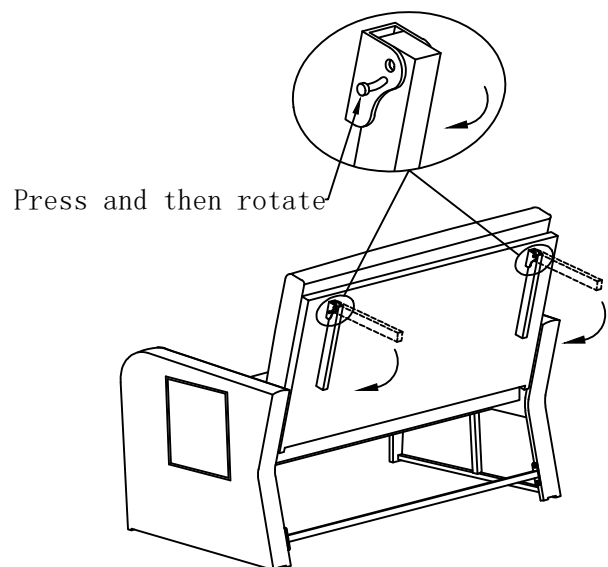

Note: Do not fully tighten any bolts until chair assembly is complete. Failure to follow these instructions may cause the bolt holes to be misaligned during assembly