

Assembly Instructions

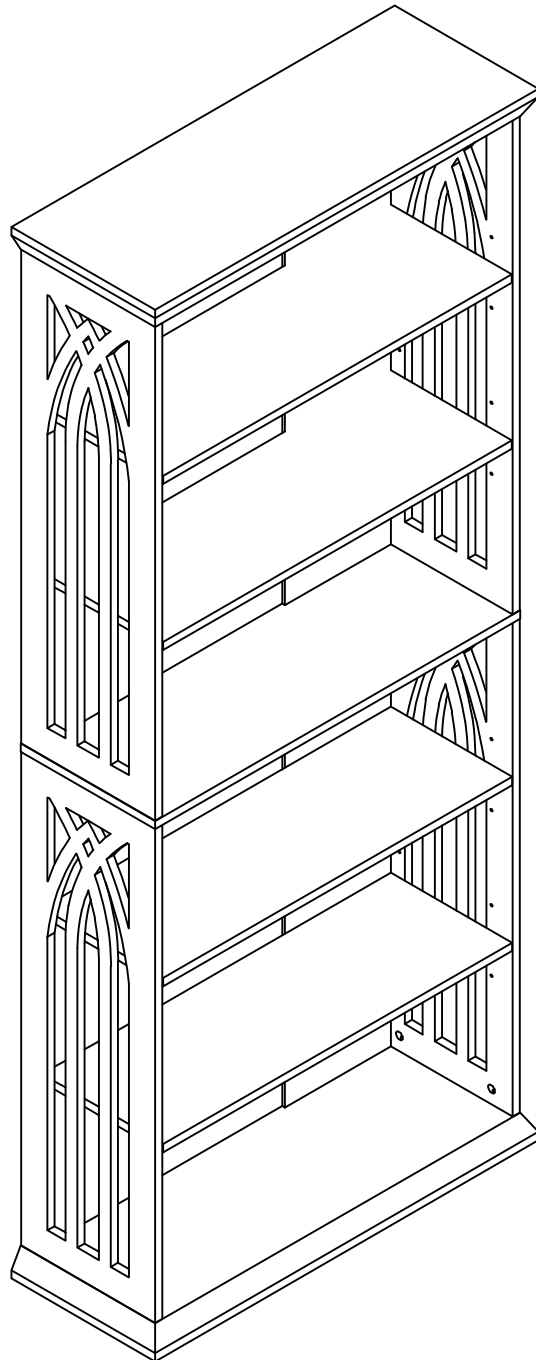

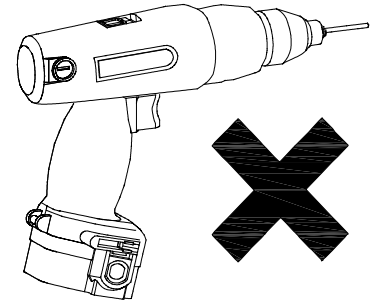
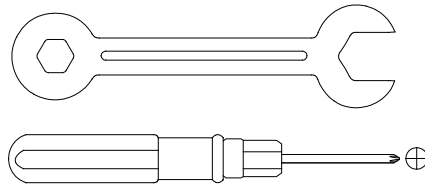
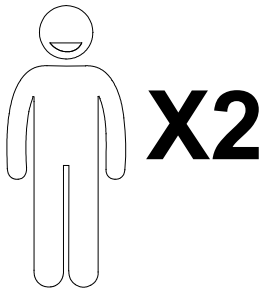

We recommend using hand tools for assembly.

If an electric screwdriver is used, reduce power and torque to avoid damage to the product.

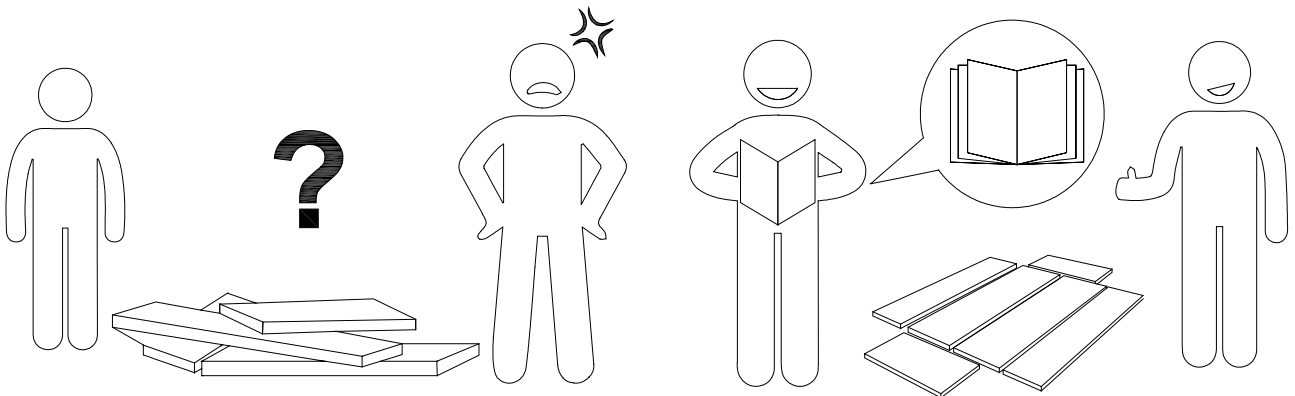

Install the Anti-Tip Straps

Using the anti-tip straps can reduce the risk of tipping over, but can not eliminate it.

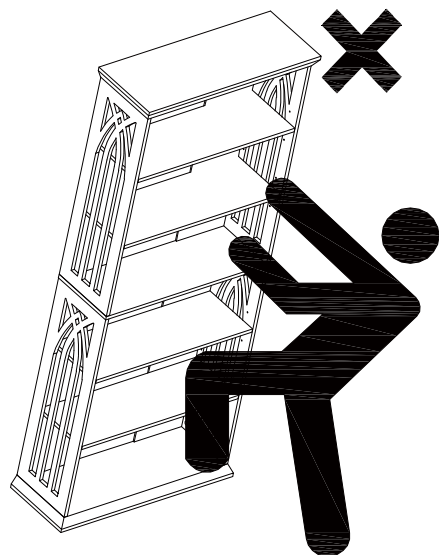
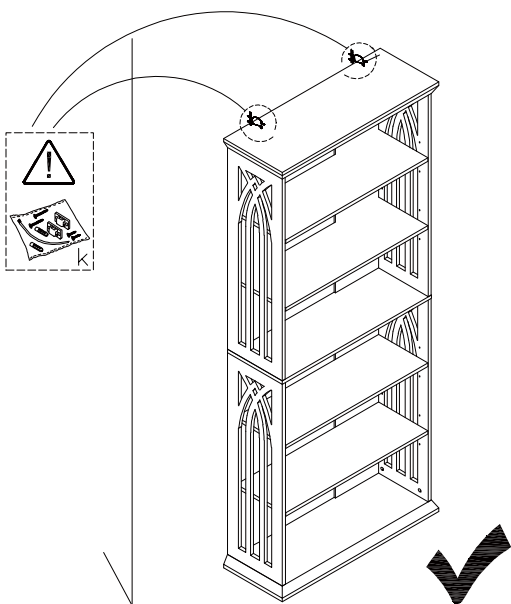

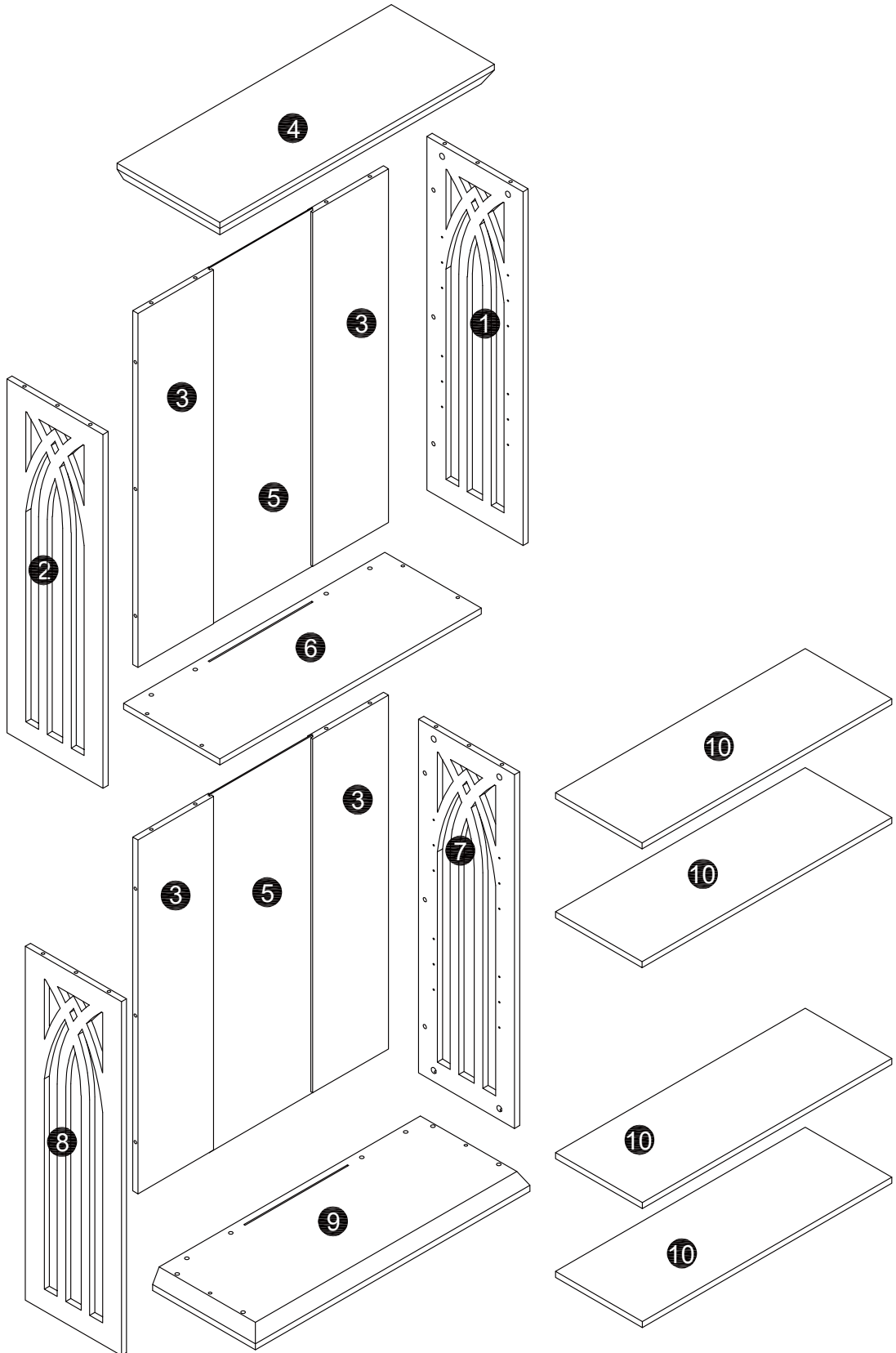



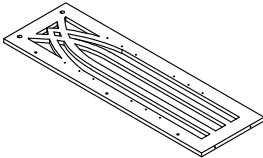
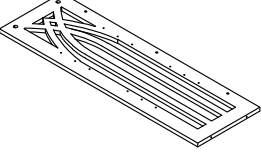
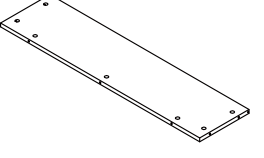
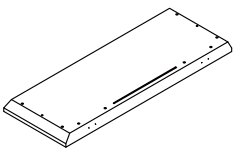
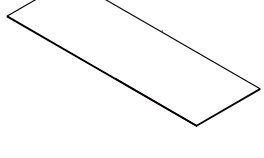
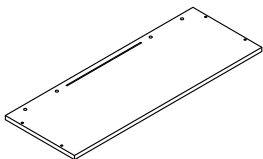
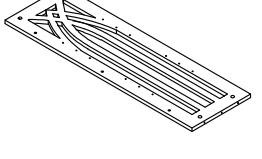
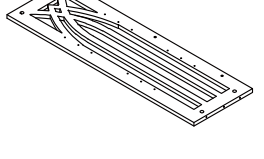
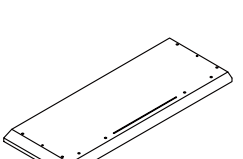
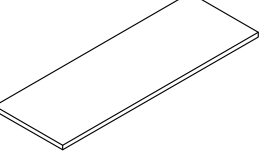

⚠ Caution

Make sure all parts are included. Most board parts are labeled or stamped on the raw edge. Contact us for a free replacement if you encounter any damaged or missing parts.

Parts List

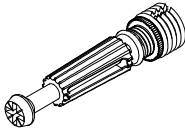
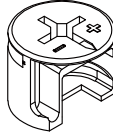
| | | | | |
|---|---|--|--|---|
| <p>1</p>  <p>1 pc</p> | <p>2</p>  <p>1 pc</p> | <p>3</p>  <p>4 pcs</p> | <p>4</p>  <p>1 pc</p> | <p>5</p>  <p>2 pcs</p> |
| <p>6</p>  <p>1 pc</p> | <p>7</p>  <p>1 pc</p> | <p>8</p>  <p>1 pc</p> | <p>9</p>  <p>1 pc</p> | <p>10</p>  <p>4 pcs</p> |

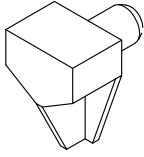
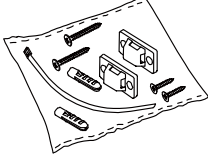
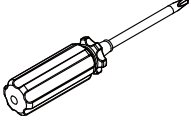
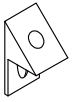
Hardware List

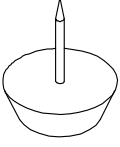
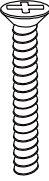
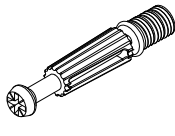
| | | | | | |
|---|--|---|---|---|--|
| <p>A</p>  <p>M6X35MM</p> <p>32 pcs</p> | <p>B</p>  <p>Ø15x12mm</p> <p>40 pcs</p> | <p>C</p>  <p>Ø8x30mm</p> <p>6 pcs</p> | <p>D</p>  <p>16 pcs</p> | <p>E</p>  <p>2 pcs</p> | <p>F</p>  <p>Screwdriver</p> <p>1 pc</p> |
| <p>G</p>  <p>14X12X10MM</p> <p>12 pcs</p> | <p>H</p>  <p>Ø3.5x14mm</p> <p>12 pcs</p> | <p>I</p>  <p>8 pcs</p> | <p>J</p>  <p>Ø7X38MM</p> <p>4 pcs</p> | <p>K</p>  <p>M6X35MM</p> <p>8 pcs</p> | |

Installation of Cams and Pins

Read each step carefully before starting. Each step of instruction should be performed in the correct order. If these steps are not followed in sequence, assembly difficulties may occur.

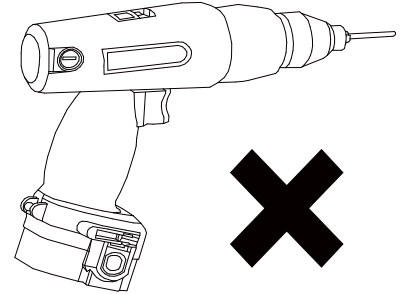

✓
No gap

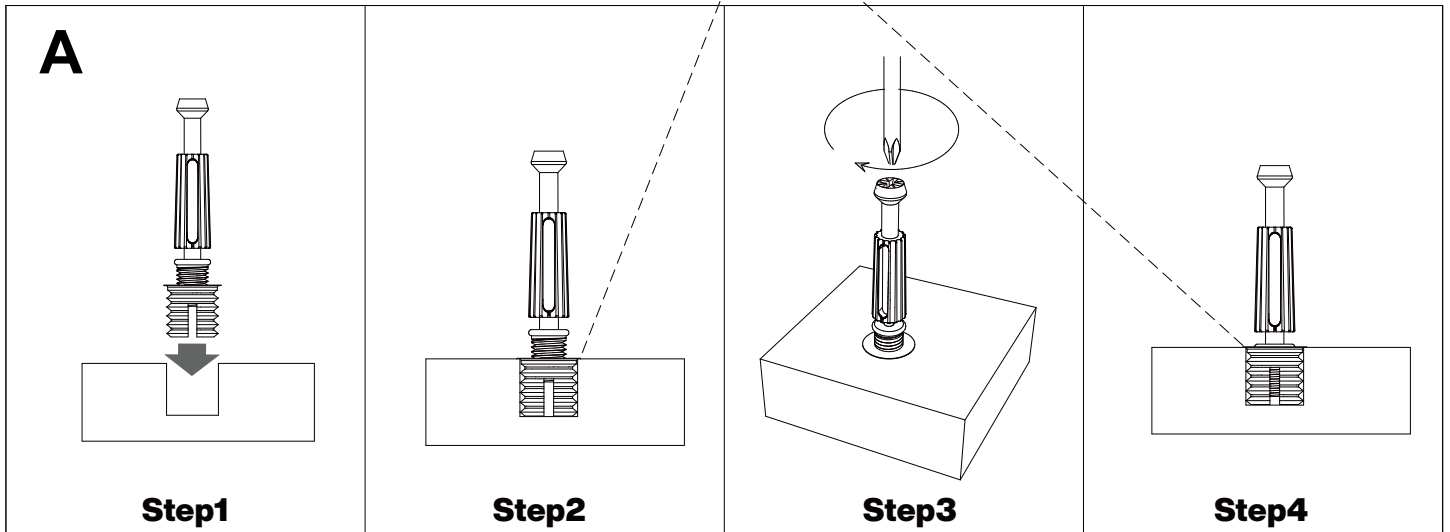

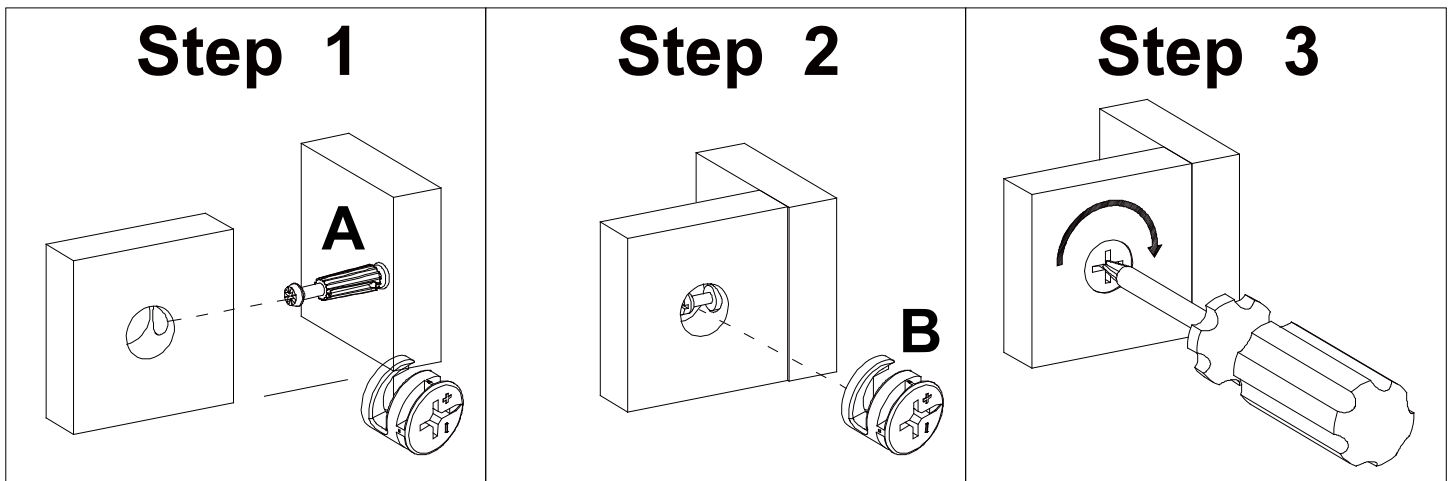

Screw the pin into the hole. Set the cams correctly by aligning the head of the cams with the lock pins. Lock the cam by turning the cam head with a screwdriver until it is tightened. Please do not use an electric screwdriver to assemble the unit.

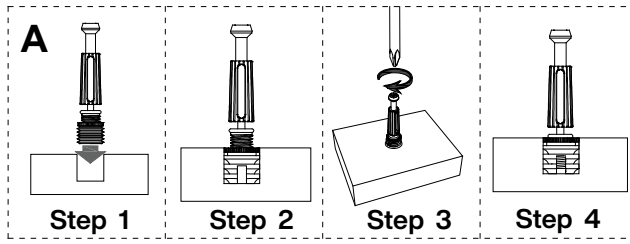

1



| | |
|---|---|
| A | K |
|  |  |
| M6x35mm 6 pcs | |

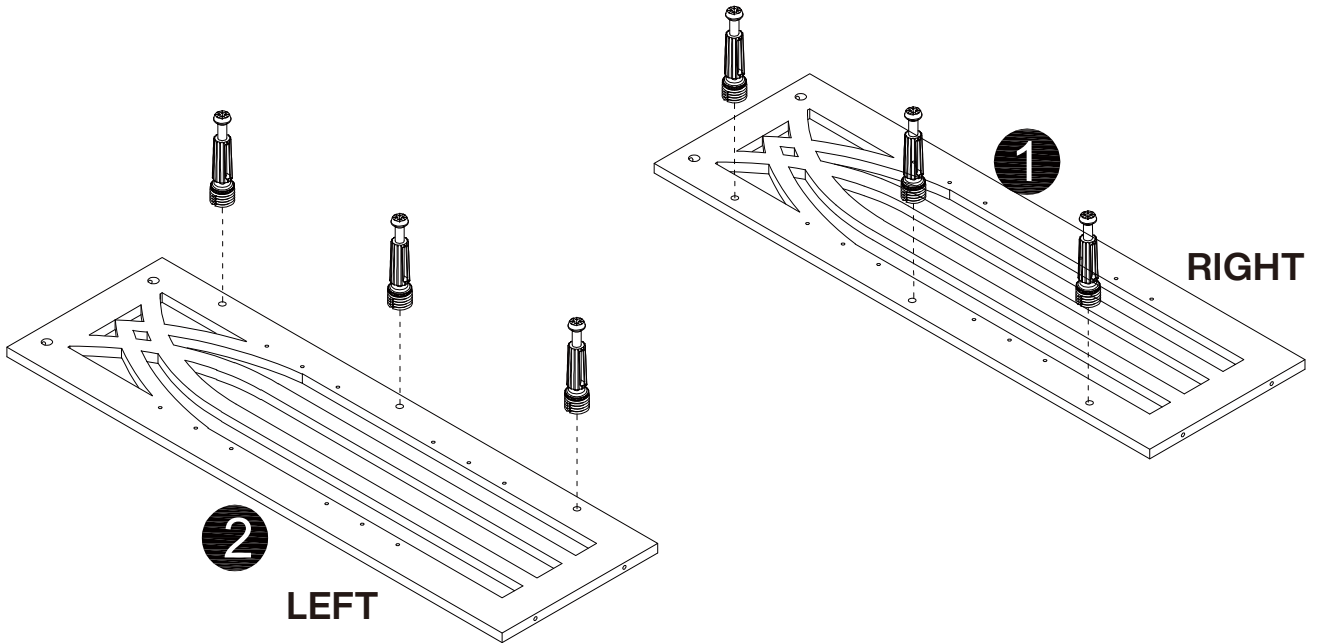

2

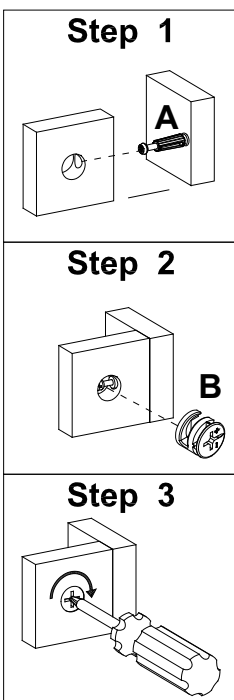

| |
|---|
| B |
|  |
| Ø15x12mm 3 pcs |

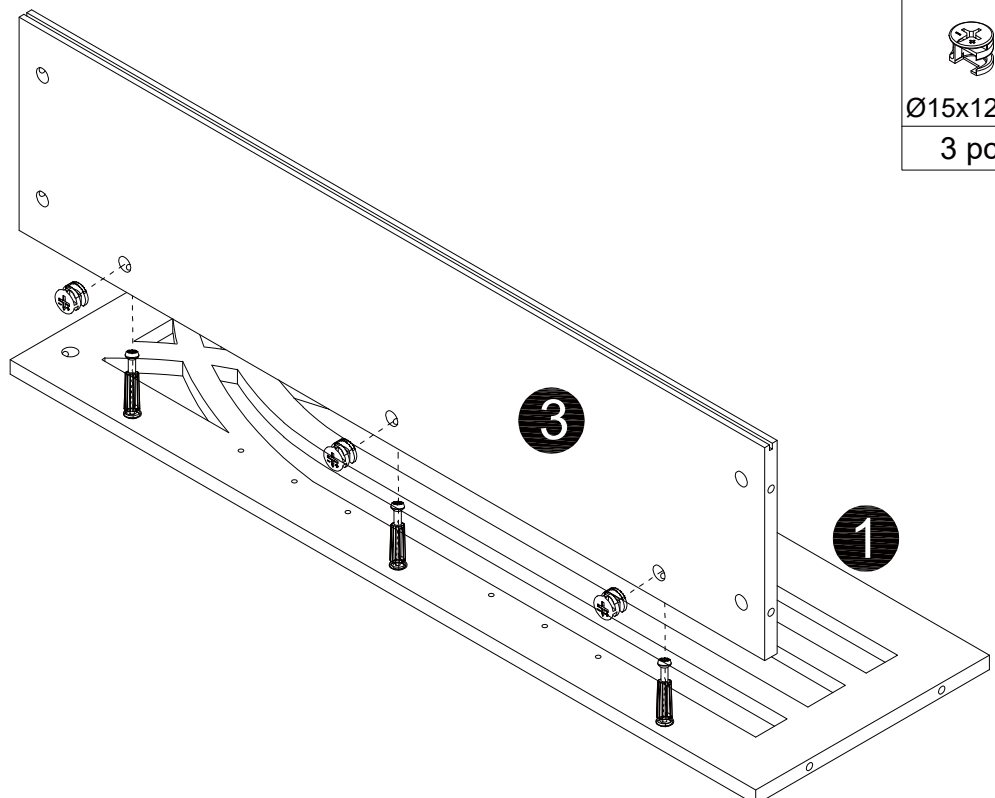

3

| |
|---|
| B |
|  |
| Ø15x12mm |
| 3 pcs |

Step 1

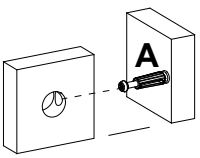

Step 2

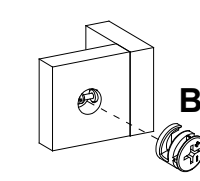

Step 3

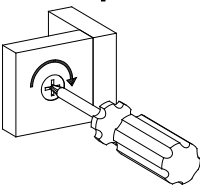
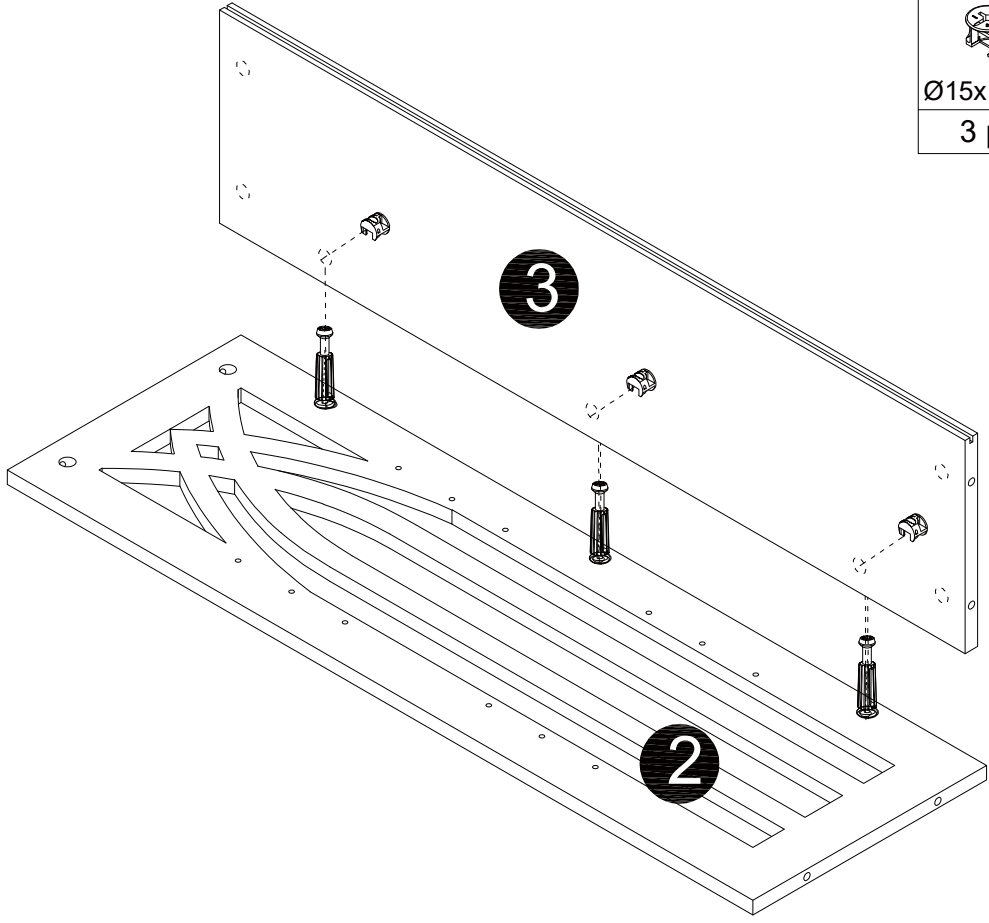

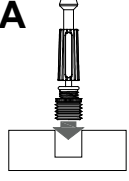

4

A

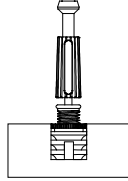

Step 2





Step 3

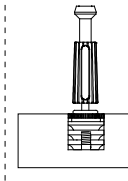

Step 4



| | | |
|---|---|---|
| C | A | K |
|  |  |  |
| Ø8x30mm | M6x35mm | |
| 2 pcs | 8 pcs | |

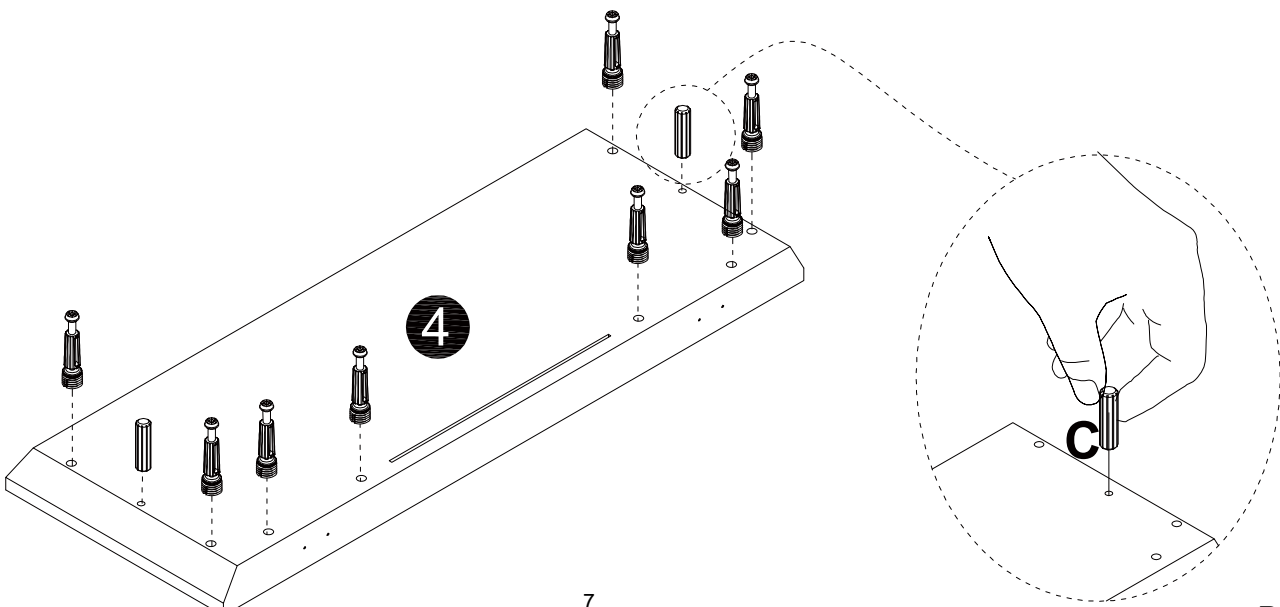

5

| |
|---|
| B |
|  |
| Ø15x12mm |
| 8 pcs |

Step 1

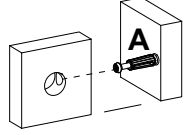

Step 2

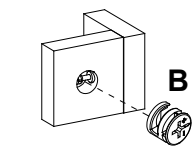

Step 3

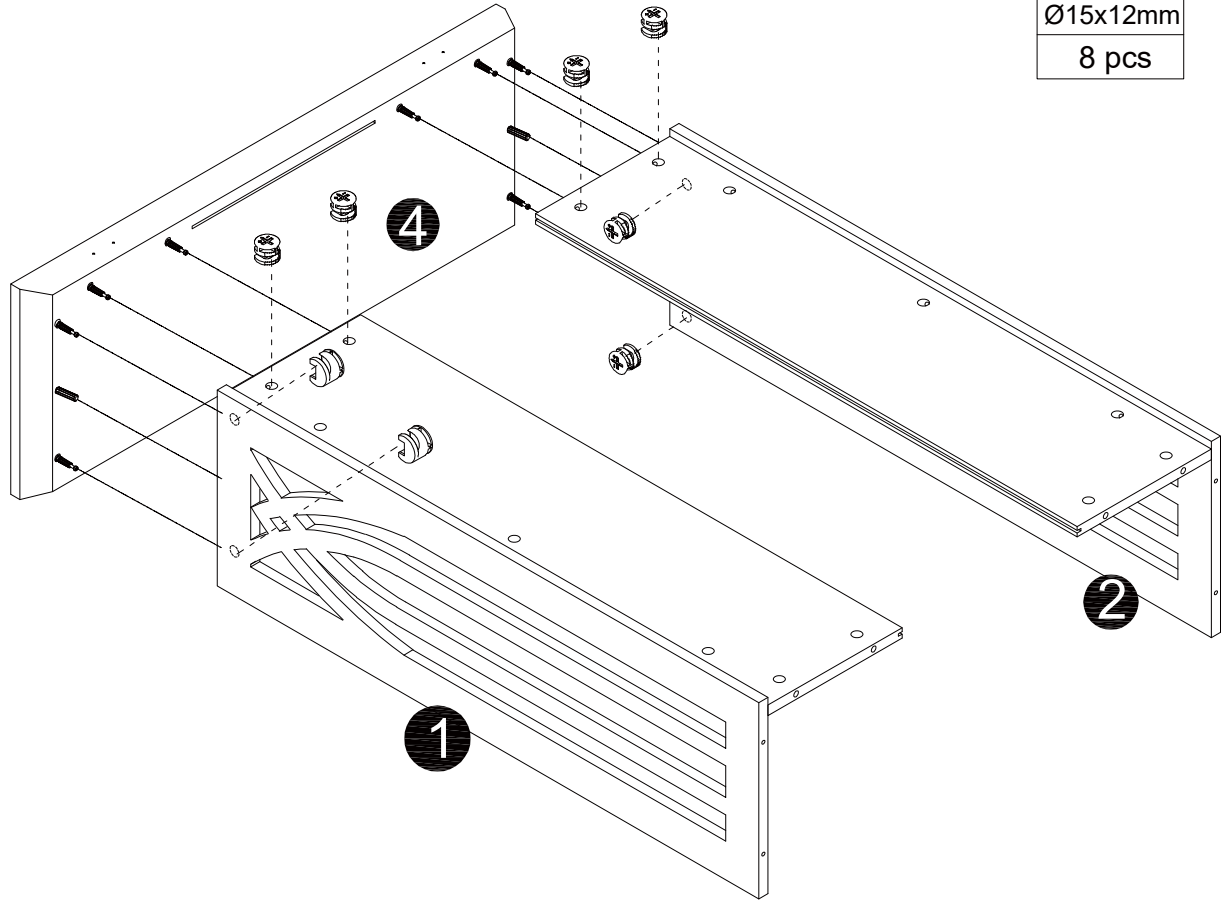
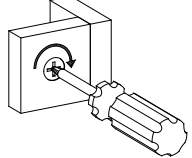

6

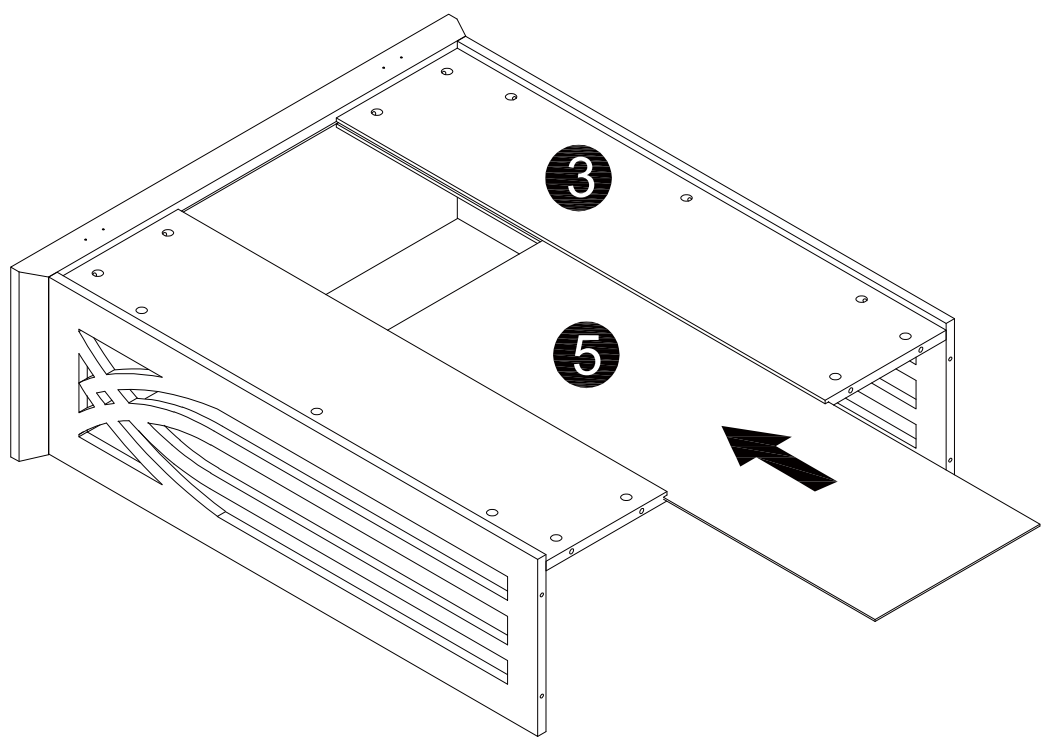

7

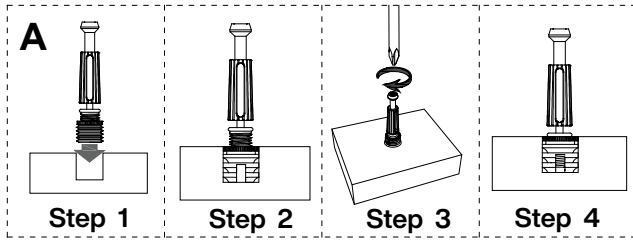

| A | K | C |
|---------|---------|---------|
| | | |
| M6x35mm | M6x35mm | Ø8x30mm |
| 4 pcs | 8 pcs | 2 pcs |

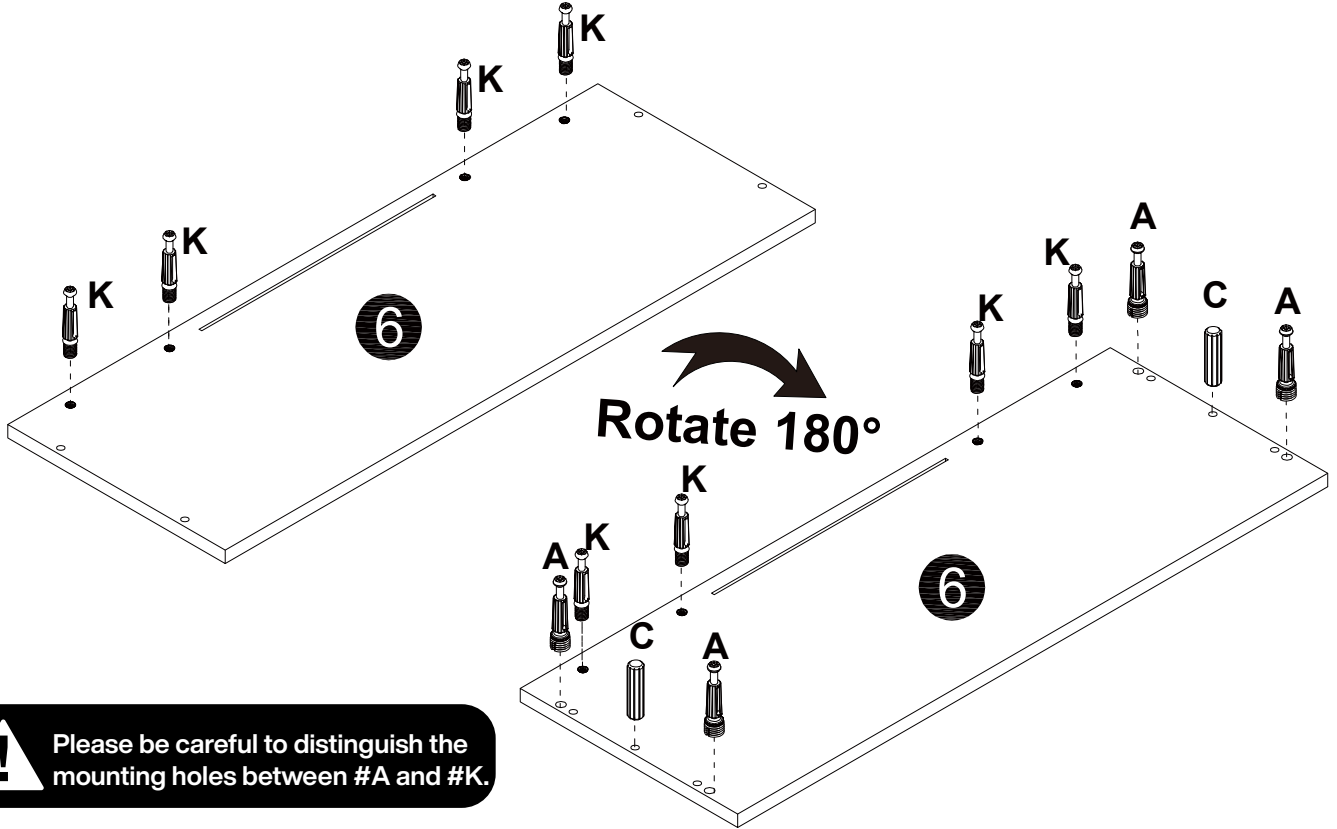

! Please be careful to distinguish the mounting holes between #A and #K.

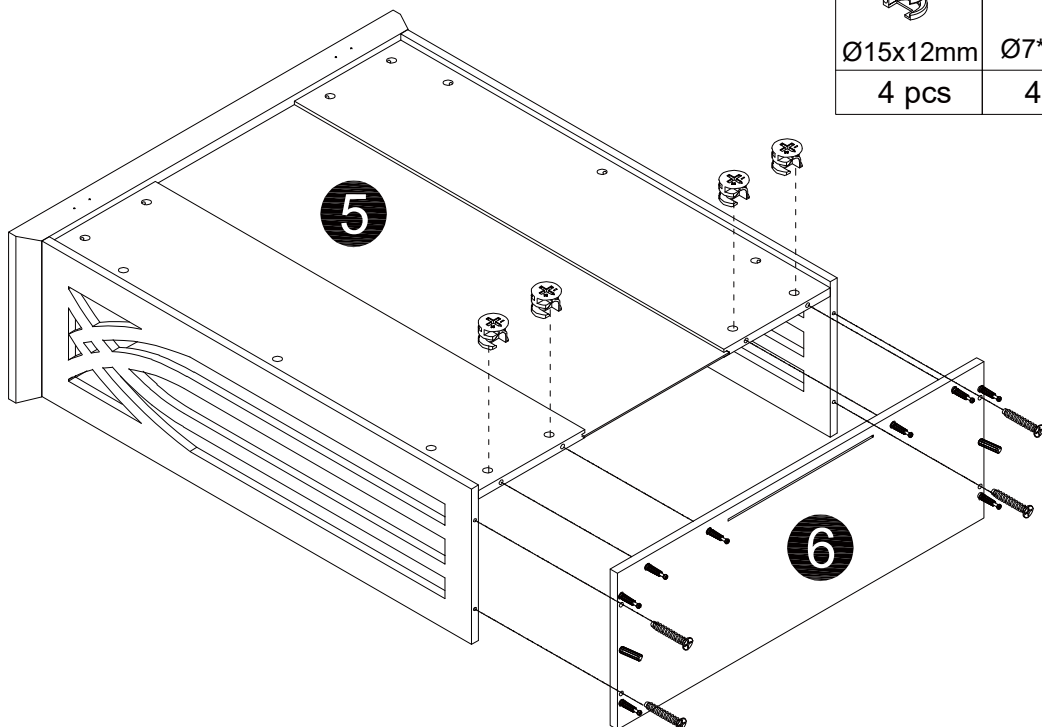
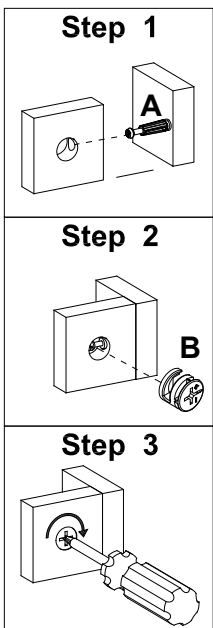

8

| B | J |
|----------|---------|
| | |
| Ø15x12mm | Ø7*38mm |
| 4 pcs | 4 pcs |

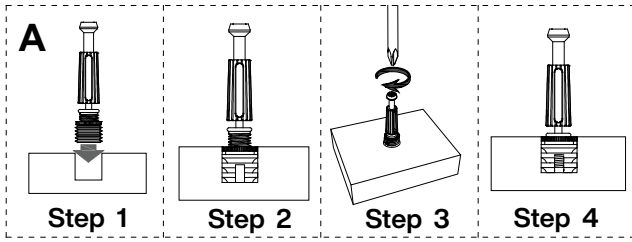

9



| A | K |
|---|---|
|  M6x35mm 6 pcs |  |

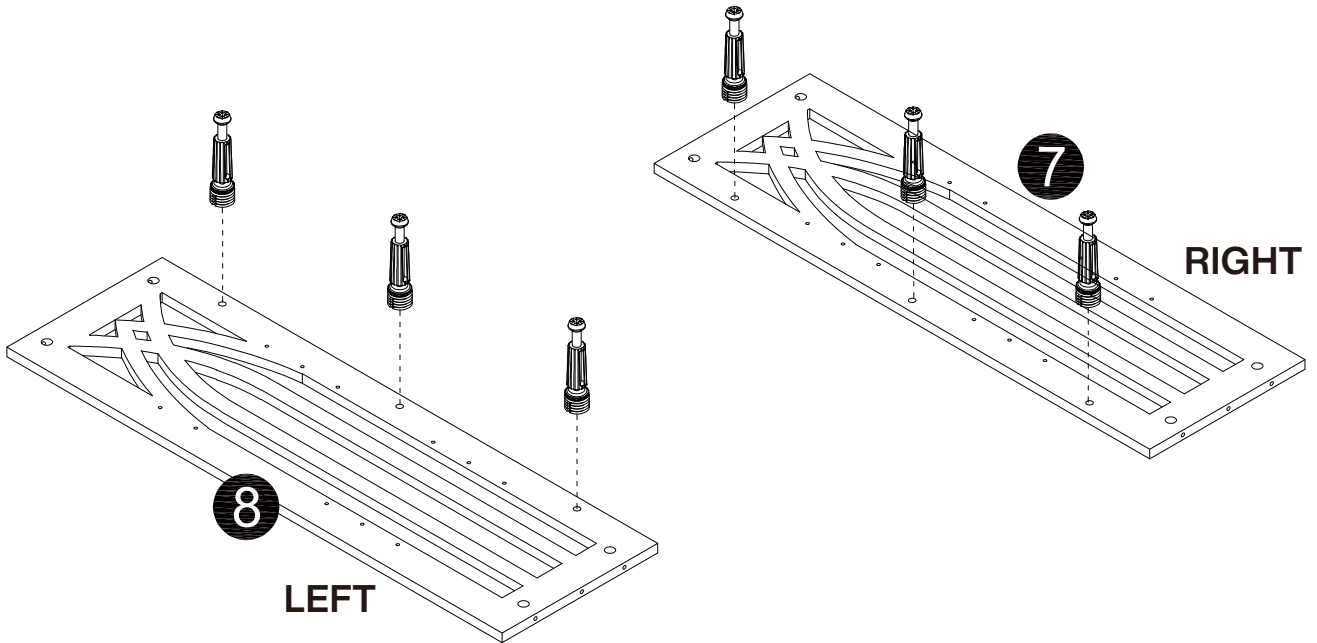

10

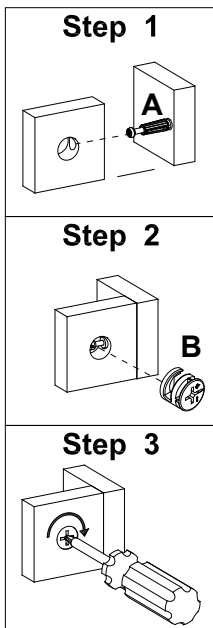

| B |
|--|
|  Ø15x12mm 3 pcs |

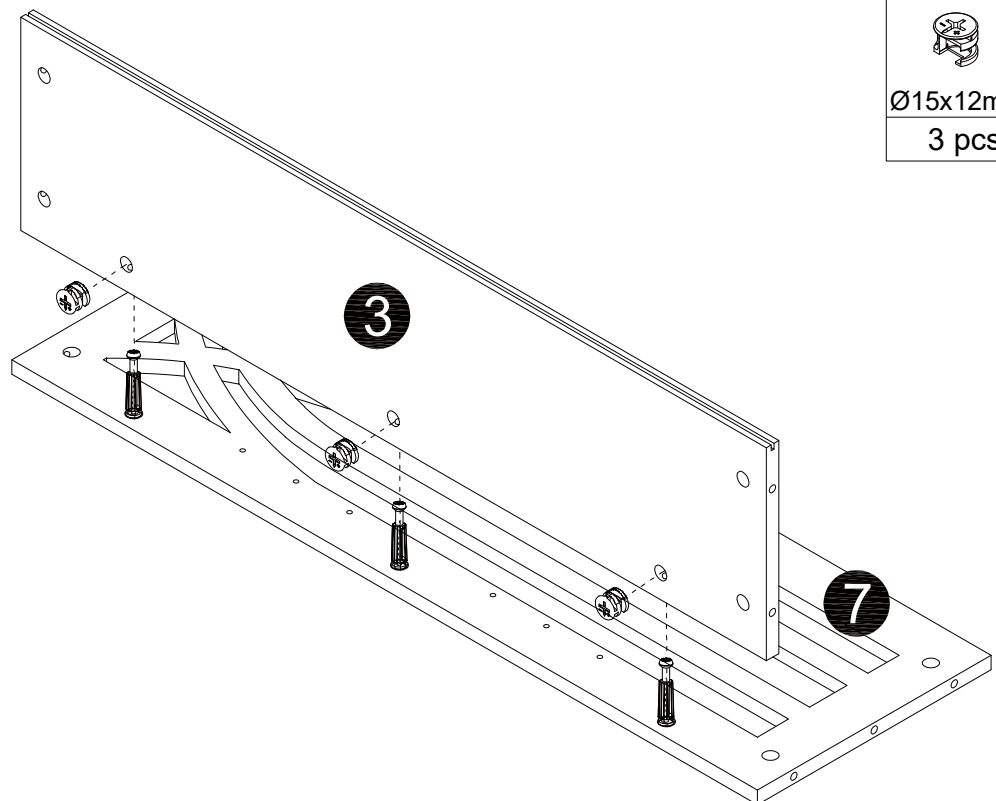

11

| |
|---|
| B |
|  |
| Ø15x12mm |
| 3 pcs |

Step 1

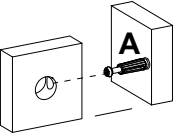

Step 2

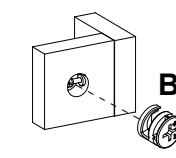

Step 3

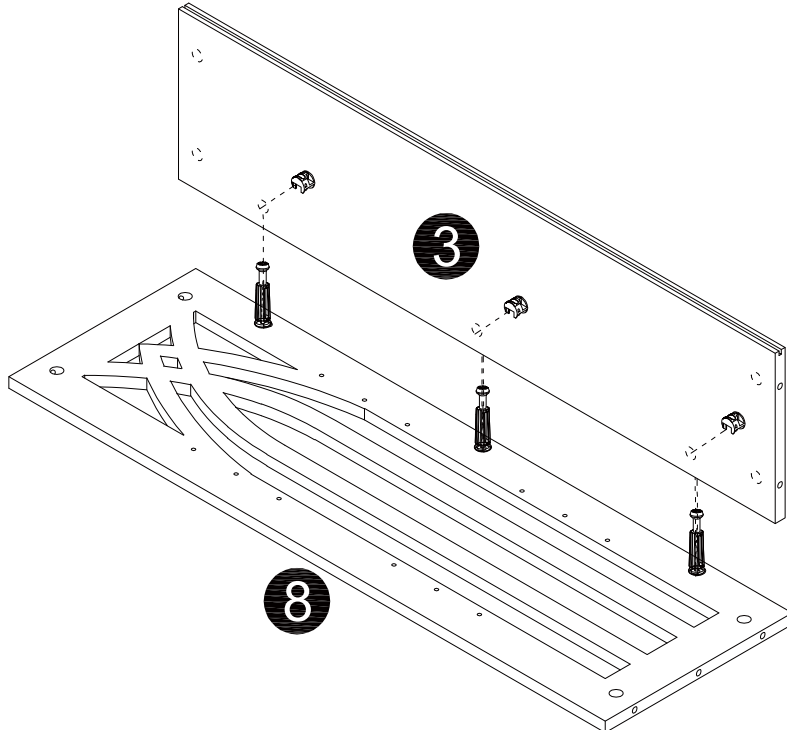
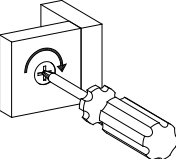

12

| |
|---|
| B |
|  |
| Ø15x12mm |
| 8 pcs |

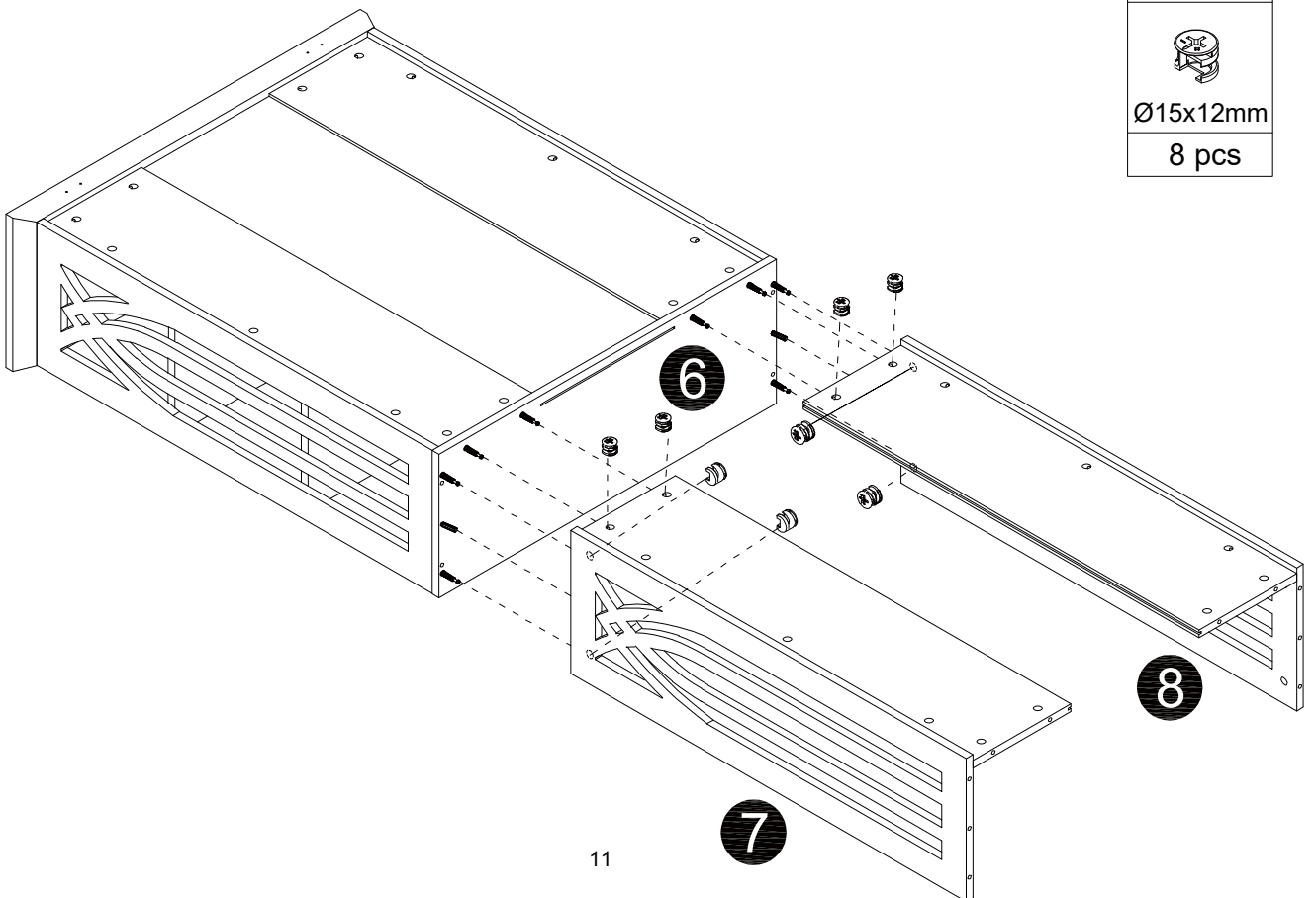

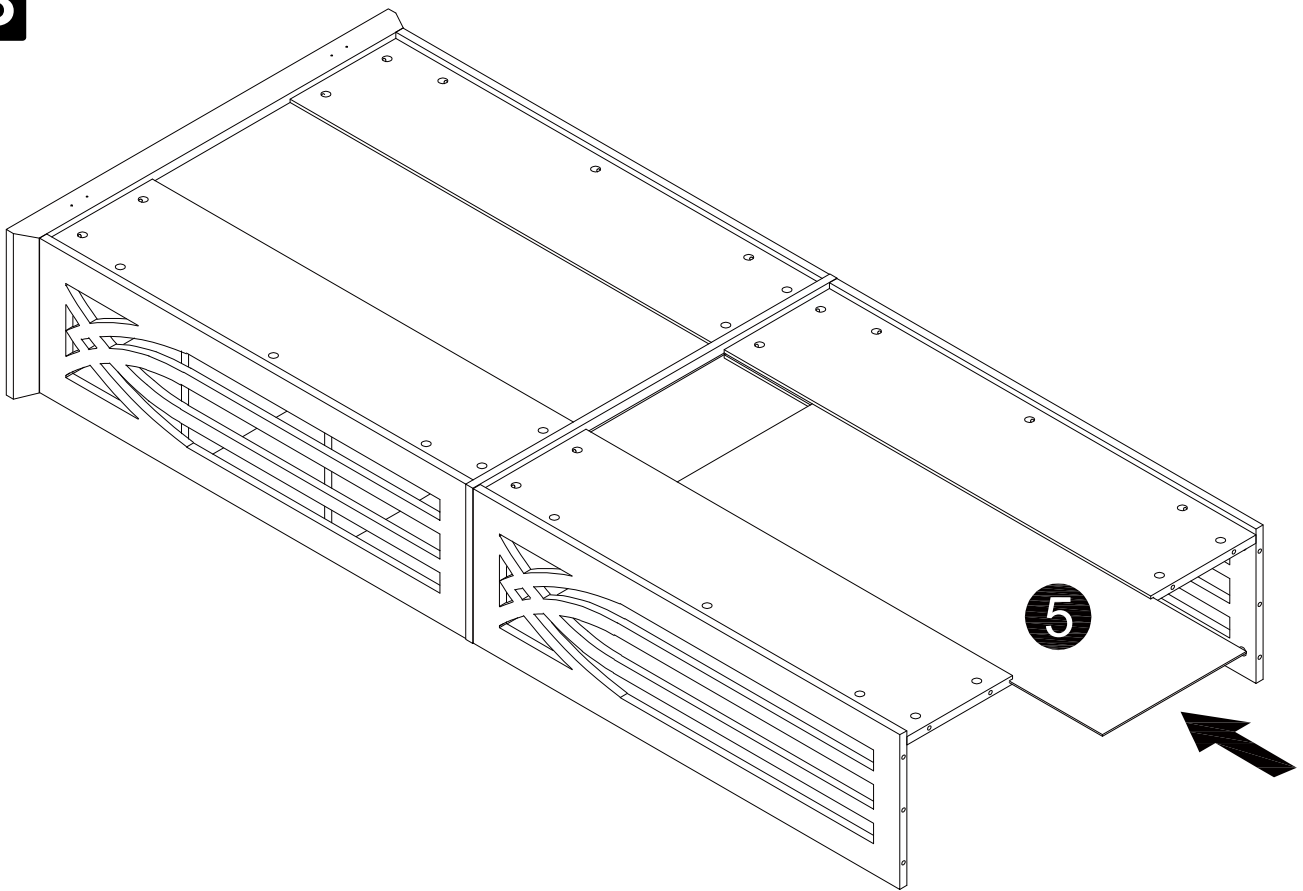

13

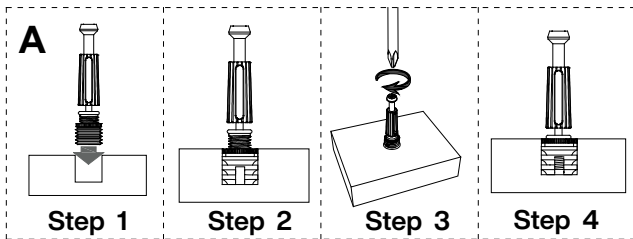

14



| C | A | K |
|---|---|---|
|  |  |  |
| Ø8x30mm | M6x35mm | |
| 2 pcs | 8 pcs | |

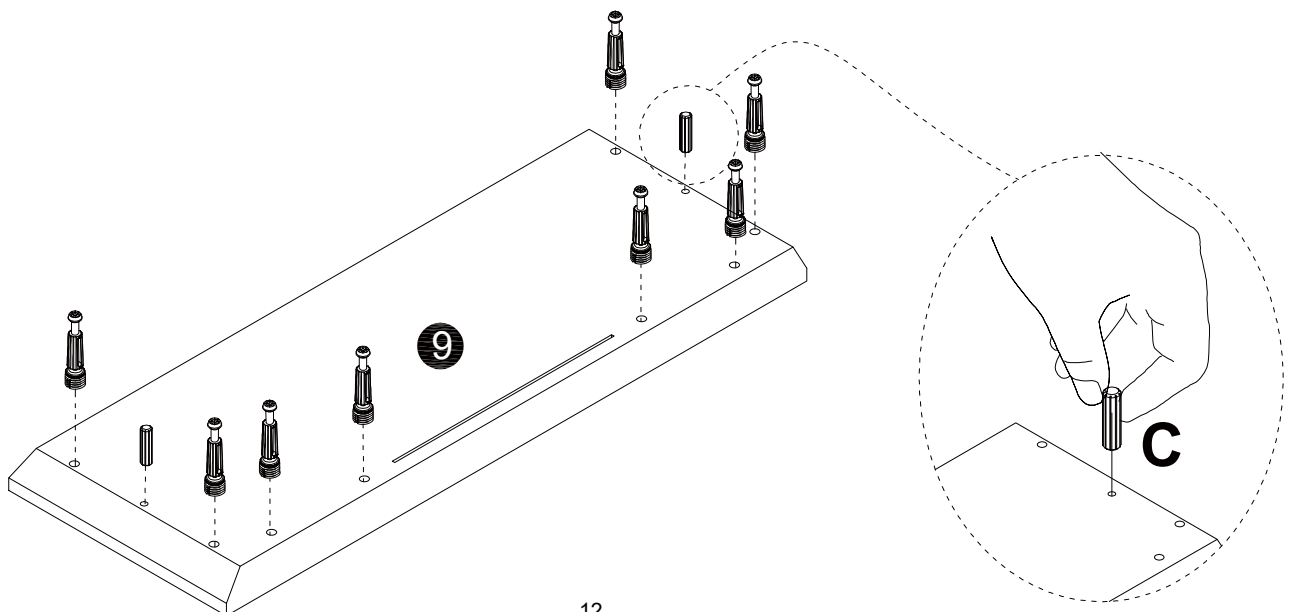

15

| |
|---|
| B |
|  |
| Ø15x12mm |
| 4 pcs |

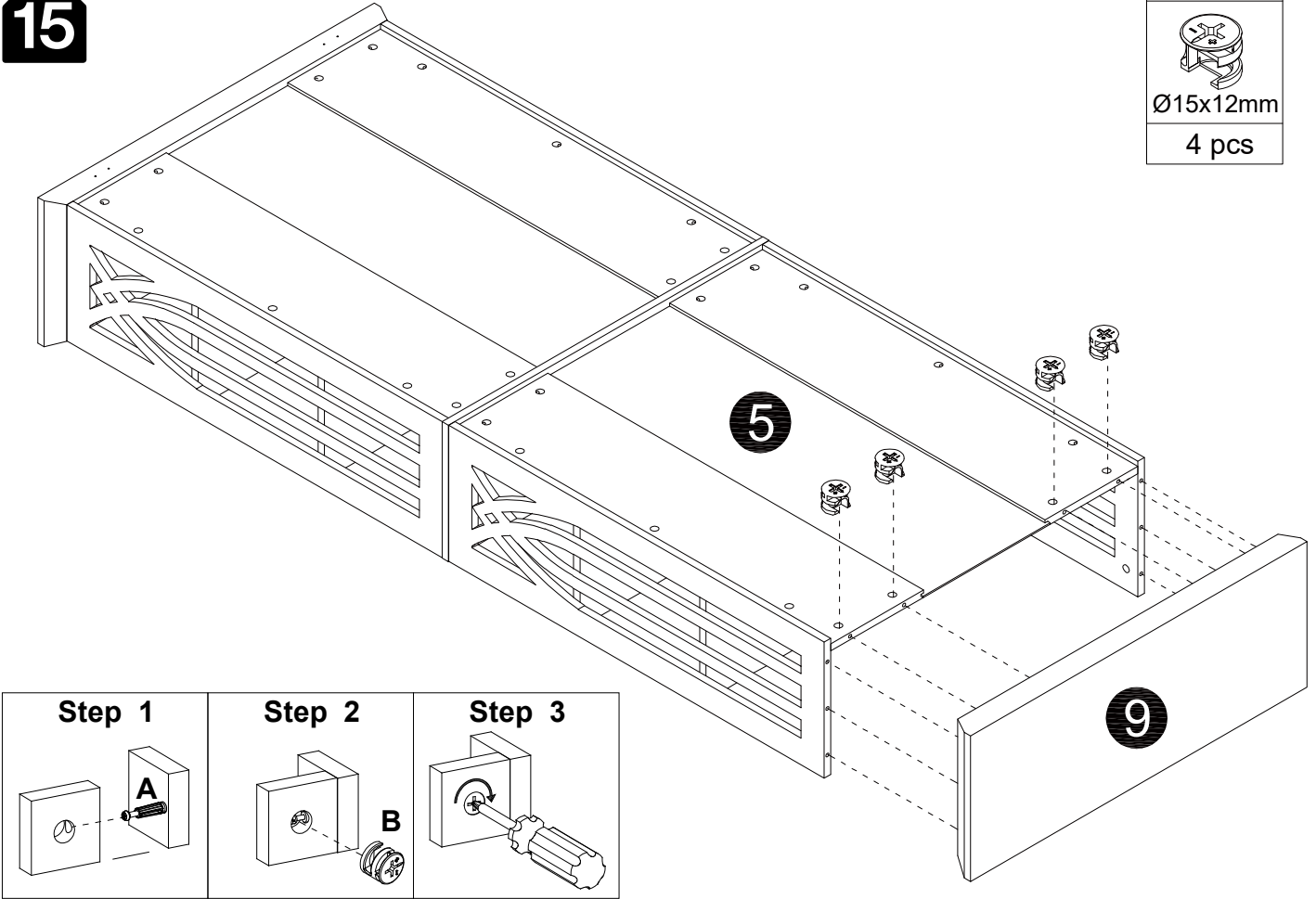

16

| |
|---|
| B |
|  |
| Ø15x12mm |
| 4 pcs |

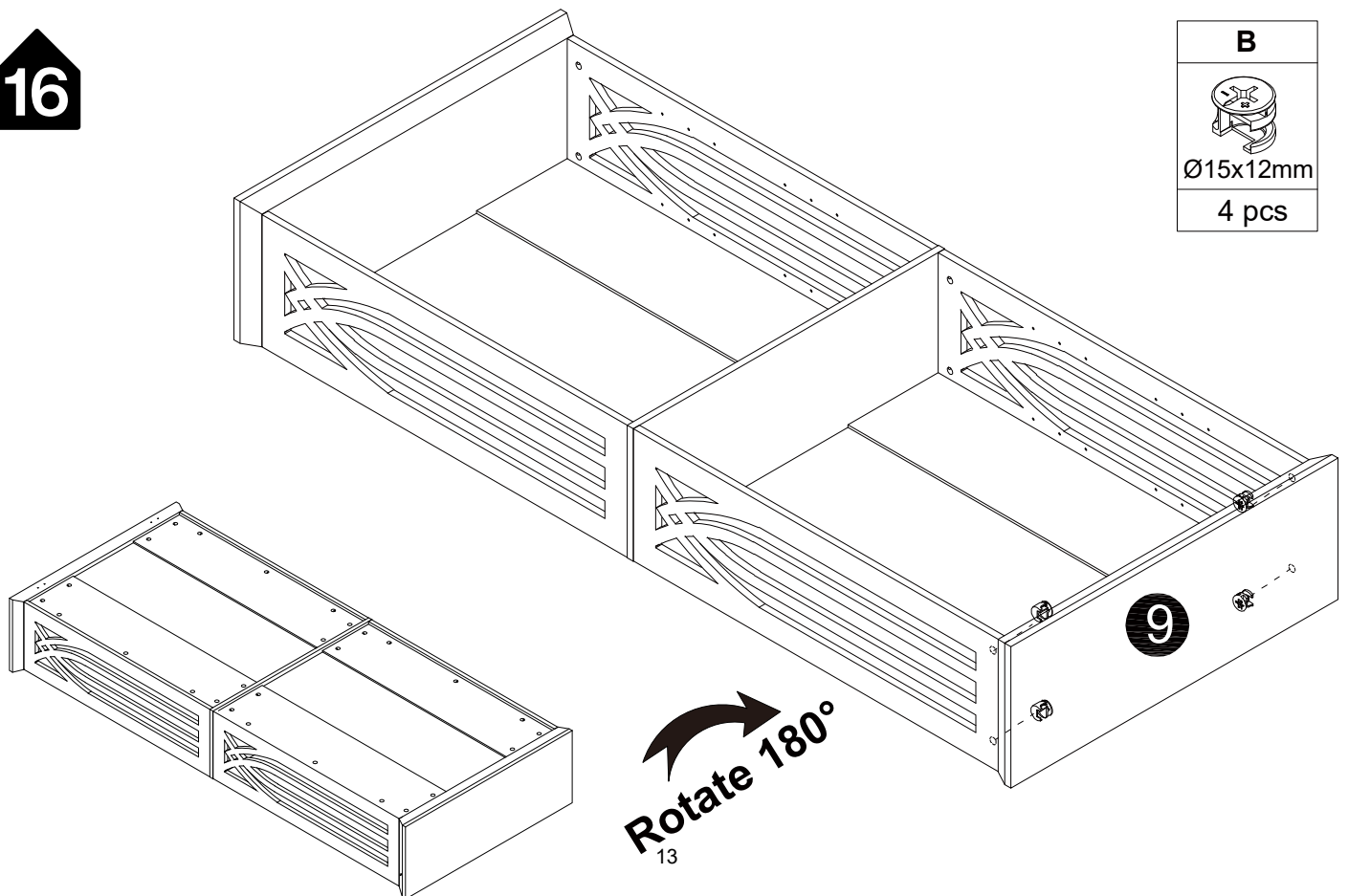

17

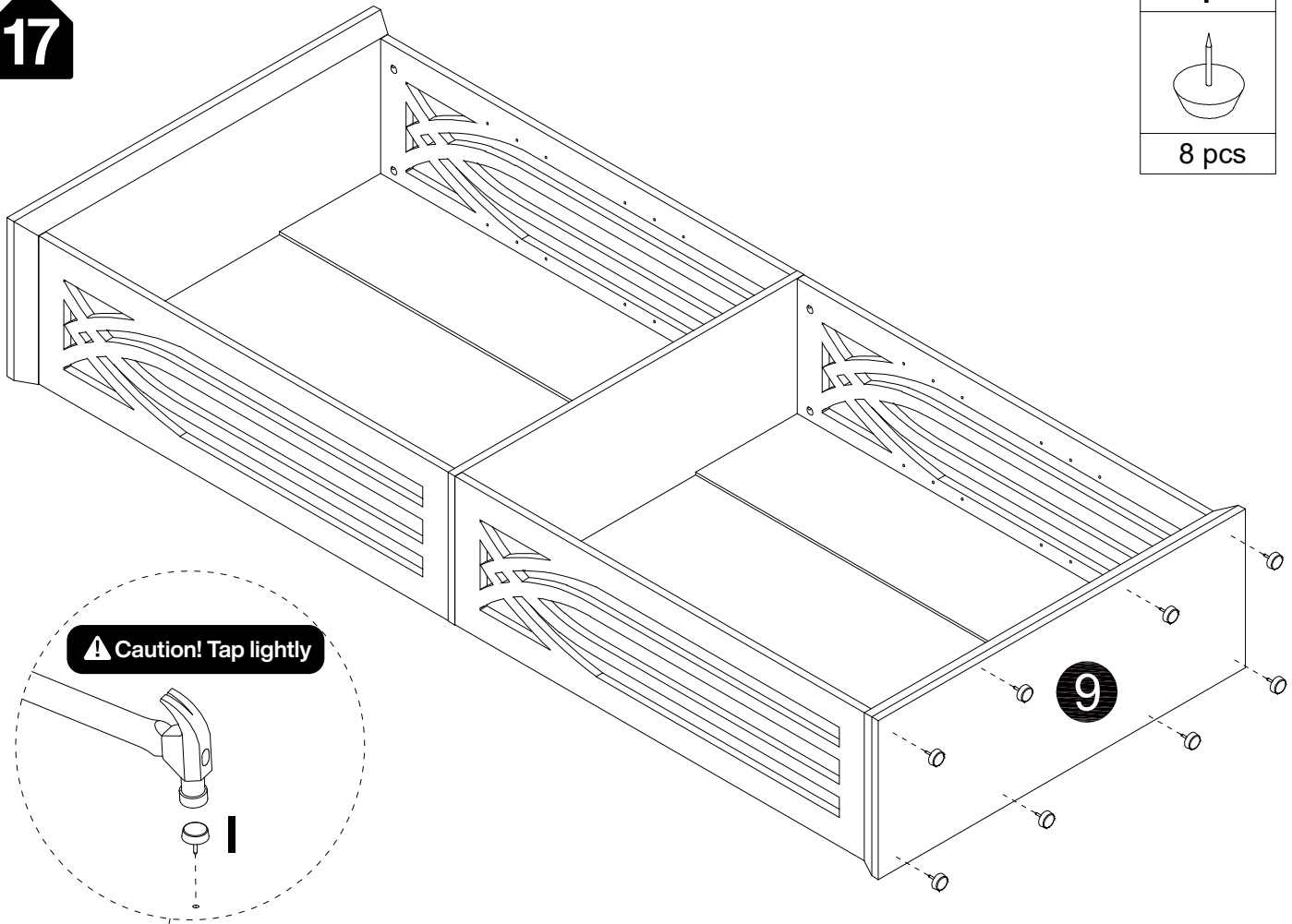

⚠ Caution! Tap lightly

| |
|-------|
| I |
| |
| 8 pcs |

18

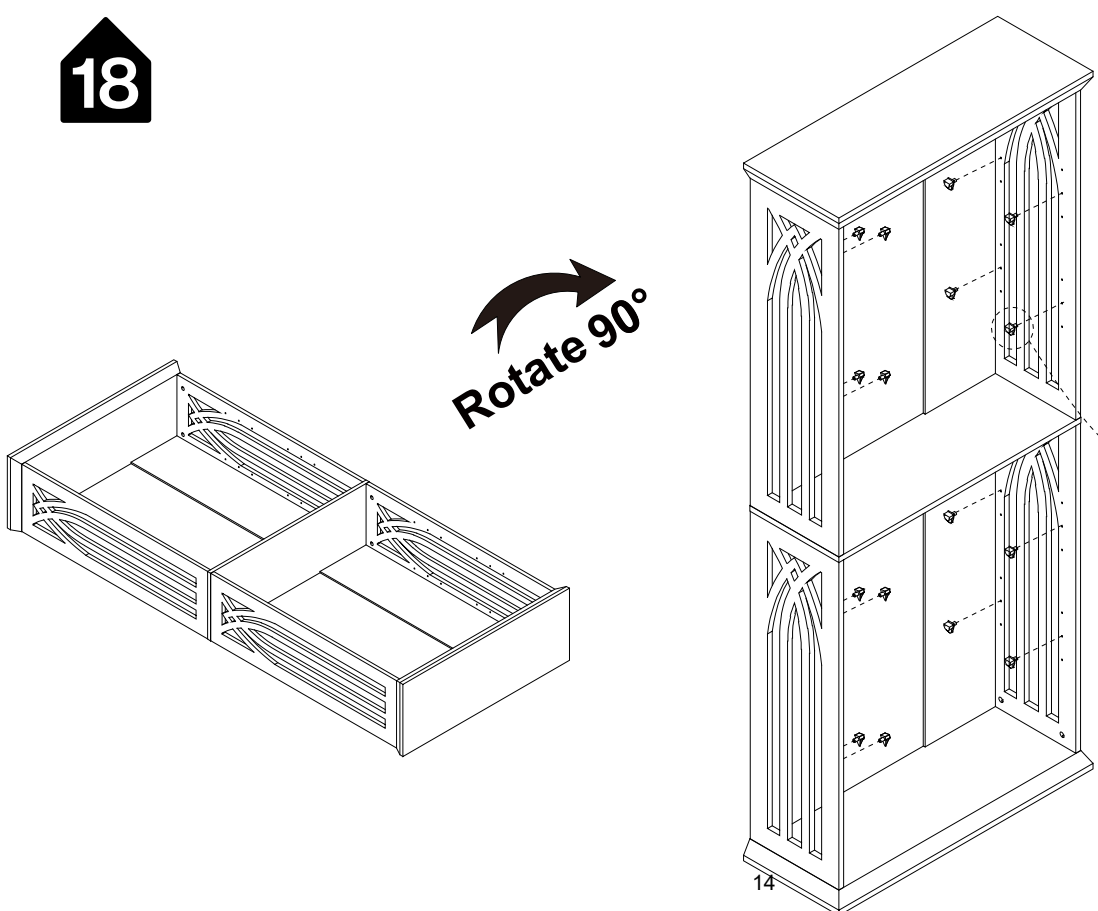

Rotate 90°

| |
|--------|
| D |
| |
| 16 pcs |

19

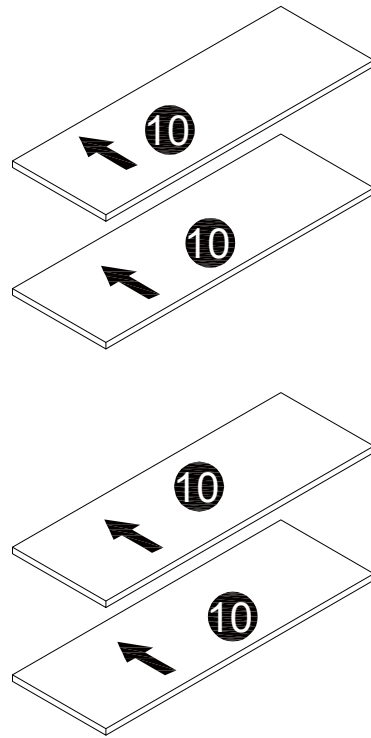
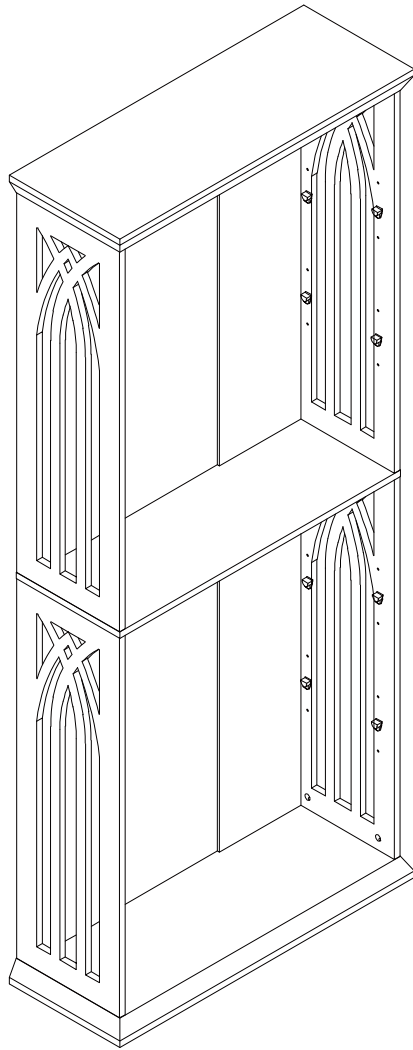

20

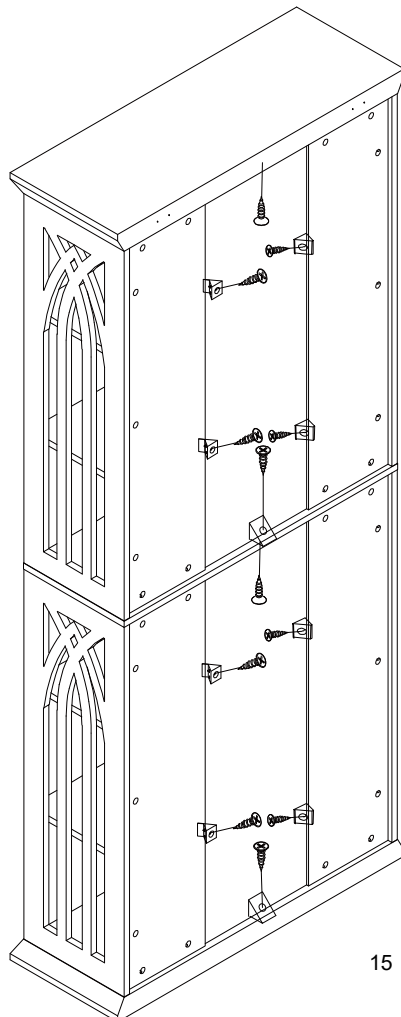

| G | H |
|--------|--------|
| | |
| 12 pcs | 12 pcs |

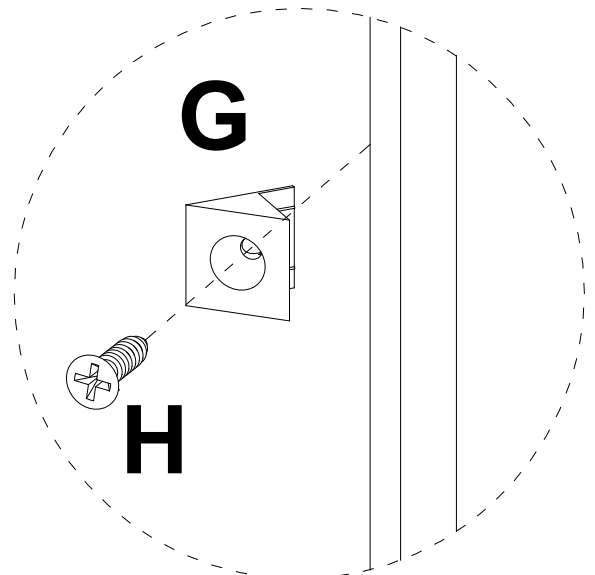

21

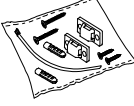
| |
|--|
| E |
|  |
| 2 pcs |

Wall

Step1

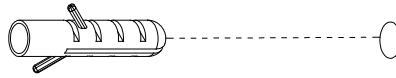

Step2

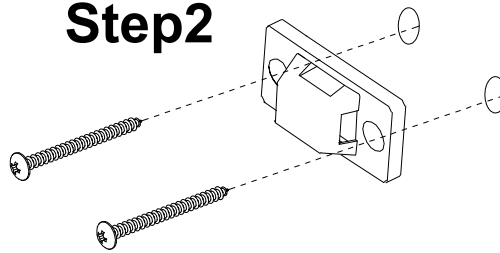

Step3

