

Mass: 191.9 kg

SHIRE  
BUILT AROUND OUR REPUTATION



Follow and Tag Us: @shiregardenbuildings

Batch: 5296

# © 8x8 Hampton

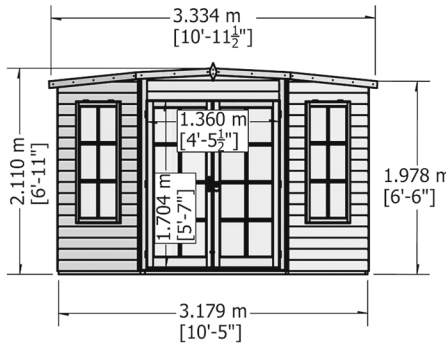
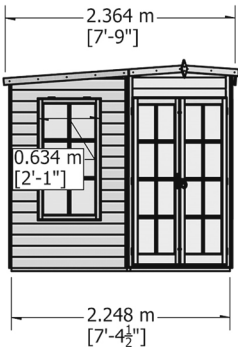

These instructions are for your safety. Please read through them thoroughly before use.  
**PLEASE KEEP THIS LEAFLET FOR FUTURE REFERENCE**

# Let's get started...

## Important information...



<b>Safety</b>	<b>03</b>
<b>Preparation of base</b>	<b>04</b>
<b>Warranty</b>	<b>04</b>
<b>Care, maintenance &amp; Recycling</b>	<b>05</b>

## In more detail...



<b>Parts List</b>	<b>06</b>
<b>Fascia &amp; Nail List</b>	<b>07</b>
<b>Detailed Technical Drawing</b>	<b>08-09</b>
<b>Hardware Chart</b>	<b>10</b>
<b>Before you start</b>	<b>11</b>
<b>Assembly Instructions</b>	<b>12-28</b>

## Like us, Follow us, Recommend us & Tag us



Shire Garden Buildings



@shiregardenbuildings



Shire Garden Buildings



customerservice@shiregb.co.uk



Brigstock Road Wisbech Cambridgeshire PE13 3JJ  
Tel 01945 465 295

## Safety

### Check that you have noted all the following instructions:



- We advise the use of non slip protective gloves throughout the assembly process.
- We advise the use of steel capped protective footwear throughout the assembly process.
- We advise that you use a helper to hold the glass in position whilst you nail the beading in place.
- We advise the use of protective headwear and safety goggles throughout the assembly process.
- Where a ladder is in use another person must hold the ladder.
- Do not attempt to work in windy conditions.
- We advise the use of a scaffold tower when fitting the roof for felting or if you cannot reach from the ground.
- Do not allow children near the tools and work area.
- Follow any safety precautions quoted by the manufacturer for any equipment you use.
- Check all parts before assembly.
- Only use child and animal safe wood preservative.
- Do not use creosote.
- Allow the wood preservative to fully dry before use.
- Regularly check the building for wear and tear.

## Important!

**EVERY PRECAUTION IS TAKEN TO ENSURE THAT YOUR BUILDING HAS NO ELEMENT INCORRECTLY PLACED OR POSSIBLY HAZARDOUS, HOWEVER PRIOR TO USE PLEASE CHECK ALL SURFACES FOR THE FOLLOWING:**

- (1) RAISED GRAIN, SPLINTERS: Sand down timber to smooth finish
- (2) NAIL/SCREW/PIN HEADS PROUD: Tap home to be flush with surface of timber.
- (3) DAMAGED SCREW HEADS RESULTING IN SHARP SPLINTERS OF METAL: Replace.
- (4) SHARP ENDS OF NAILS/ SCREWS/ PINS PROTRUDING THROUGH THE PANEL: Remove and Reposition.
- (5) ENSURE ALL PARTS ARE SECURED AGAINST REASONABLE FORCE: Remove and Refit.
- (6) ENSURE THERE ARE NO LOOSE PARTS: Remove and Refit/Discard.



**IMPORTANT !** For your safety please read carefully the safety warnings

## Preparation of base...

We recommend that the base onto which your building will stand should be at least 75mm larger in each direction than the total floor size of the building.

- **Actual floor area of the building:** 2248mm x 2248mm
- **Total height clearance:** 2110mm
- **Roof size:** 2364mm x 2364mm

The chosen position in your garden for your building should be excavated to a depth of 75mm to allow a base of sand, onto which paving slabs can be evenly laid.

You may also use an adjustable timber base or a concrete base. Whatever base you decide upon IT MUST BE LEVEL AND FIRM.

## Warranty...

### 10 Year anti-rot warranty subject to the following:

- The building must be raised so it is not in contact with any water retaining base surface (for example grass).
- This can be achieved using a timber, concrete or slab base.
- When using a concrete or slab base use damp proofing strips under the bearers.
- The building must have been completely treated and sealed immediately prior to assembly.
- The building must have been re-treated and re-sealed annually.

**NOTE:** Wood is a natural product, and therefore the following are excluded from the warranty:

- Colour change.
- Warping.
- Splitting.

### The following are also excluded:

- Damage resulting from poor assembly.
- Poor treatment application.
- Poor care and maintenance.
- Changes to the design.
- Misuse.
- General wear and tear.

EN	For a copy of the instructions or a copy in another language please send an email or write to the address below.
F	Pour obtenir un exemplaire des instructions ou une copie dans une autre langue s'il vous plaît envoyez un e-mail ou écrire à l'adresse ci-dessous.
I	Per richiedere una copia del libretto di istruzioni, in italiano, o in un'altra lingua, per favore, invia una e-mail o scrivi a l'indirizzo sottostante.
PL	Na kopii instrukcji lub kopii w innym języku prosimy o wysłanie maila lub pisać na adres podany poniżej.
RUS	Для получения копии инструкции или копия на другом языке, пожалуйста, отправьте по электронной почте или написать по указанному ниже адресу.
TR	Başka bir dilde talimatları veya bir kopyasını bir kopyası için bir e-posta gönderebilir veya aşağıdaki adrese yazınız.

## Care, Maintenance and Recycling

### The 5 golden rules of care:

- (1) Ensure your base is level and firm.
- (2) Ensure the building is not sitting directly on the ground using damp proof membrane or the optional timber base.
- (3) Ensure every piece of timber and surface, especially that is hidden upon assembly, is treated with a top quality wood preservative at least twice (before assembly). Turn the panels upside down whilst painting so the treatment runs into the seams.
- (4) Garden buildings are not waterproof, therefore you must seal between all the panels with a silicone based sealant.
- (5) Regularly check your roofing felt for weather damage and leaks.

### The 6 golden rules of maintenance:

- (1) Visually check for weather damage.
- (2) Check and replace if necessary any silicone sealant if used on your building.
- (3) Check the roofing material for wear.
- (4) The doors and windows may require periodical adjustment.
- (5) Ensure your building is well ventilated especially during hot weather.
- (6) During extremely hot periods, humidify your building to prevent the timber from drying out.

### Recycling and disposal:



packaging

1. Pallet and timber widely recycled.
2. Cardboard widely recycled.
3. Plastic strapping subject to local regulations.
4. Plastic sheeting subject to local regulations.



Building

1. Timber widely recycled.
2. Metal fixings widely recycled.
3. Glass widely recycled.
4. **Roofing felt not currently recycled.**

Description  
(part No.) - Qty

# Stacked Parts List

SQUARE FLOOR  
(A4119)x01

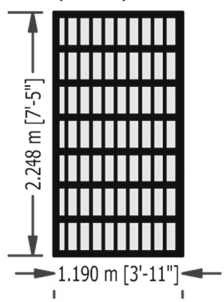

ANGLED FLOOR  
(A4119)x01



PLAIN PANEL 1089  
(A4120)x04

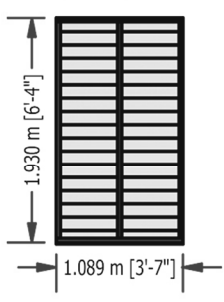

RH WINDOW PENT  
(A1416)x01

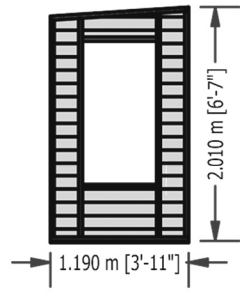

LH WINDOW PENT  
(A1417)x01

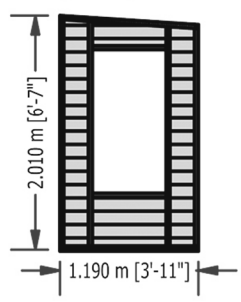

GABLE  
(A1318)x01

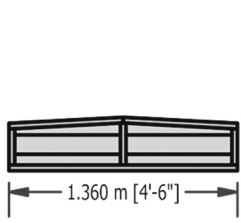

LH BACK ROOF  
(A4121)x01

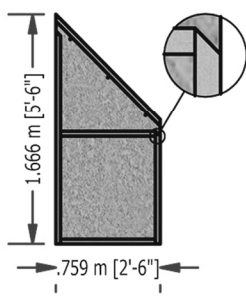

RH BACK ROOF  
(A4122)x01

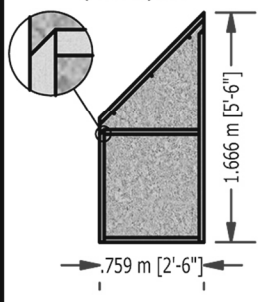

LH FRONT ROOF  
(A4123)x01

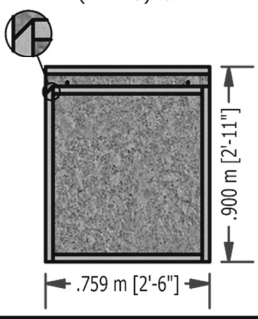

RH FRONT ROOF  
(A4124)x01

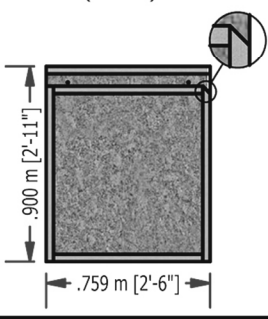

LH CORNER ROOF  
(A4128)x01

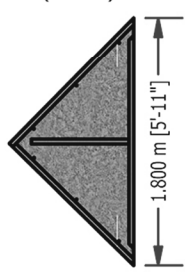

RH CORNER ROOF  
(A4129)x01

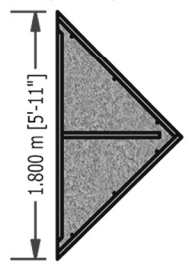

GLASS 268X373  
(A0020)x28

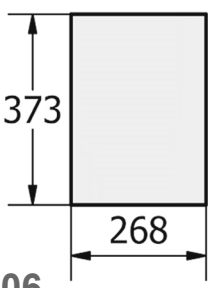

HAMPTON PRIMARY DOOR  
(B0058-P)x01

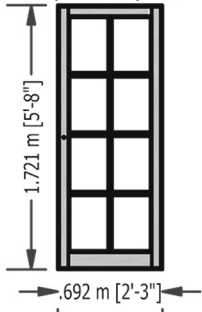

HAMPTON SECONDARY DOOR  
(B0058-S)x01

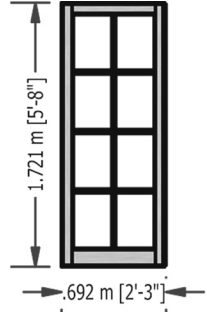

WINDOW SASH  
(B0025)x02

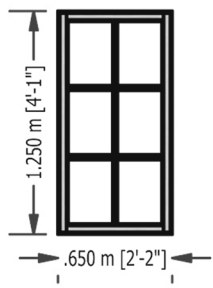





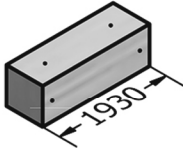
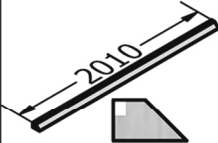
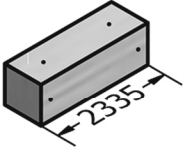
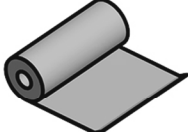

# Stacked Parts List

Description  
(part No) - Qty

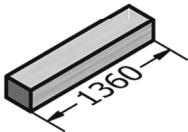
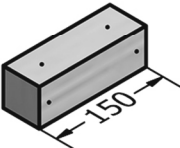
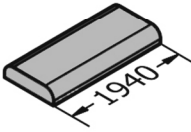
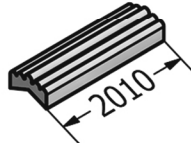
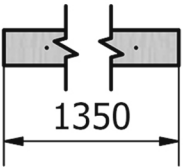
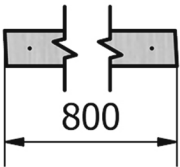
<p>44X44X1930 (A1385)x01</p> 	<p>SHAPED CORNER POST 44X78 (A1386)x02</p> 	<p>44X44X2335 (A4136)x01</p> 	<p>FELT STRIP 10M (A06099)x01</p> 	
---	--	--	---	--

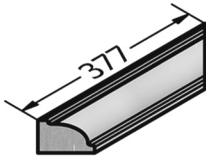
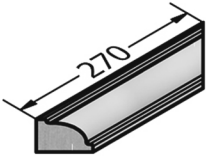
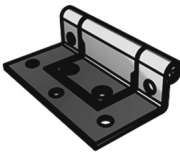
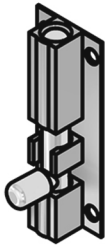
Description  
(part No) - Qty

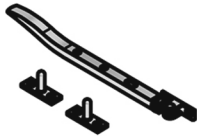
# Fascia and Nail Bag Parts List

<p>1360X44X25 (A1387)x01</p> 	<p>44X44X150 (A5943)x02</p> 	<p>COVERSTRIP 12X46X1940 (A1393)x04</p> 	<p>PROFILED COVERSTRIP 19X34X2010 (A4106)x02</p> 	
<p>FASCIA 12X70X1300 (A5960)x02</p> 	<p>FASCIA 12X70X800 (A5961)x02</p> 	<p>DIAMOND (A0019)x01</p> 	<p>BEADING 377MM (A0021)x56</p> 	<p>BEADING 270MM (A0022)x56</p> 
<p>STORM HINGE 2.5" (A0013)x10</p> 	<p>BARREL BOLT (A0014)x02</p> 	<p>GATE LATCH (A0015)x01</p> 	<p>CASEMENT STAY (A0038)x02</p> 	<p>TURN BUTTON (A1388)x02</p> 

In more detail.....

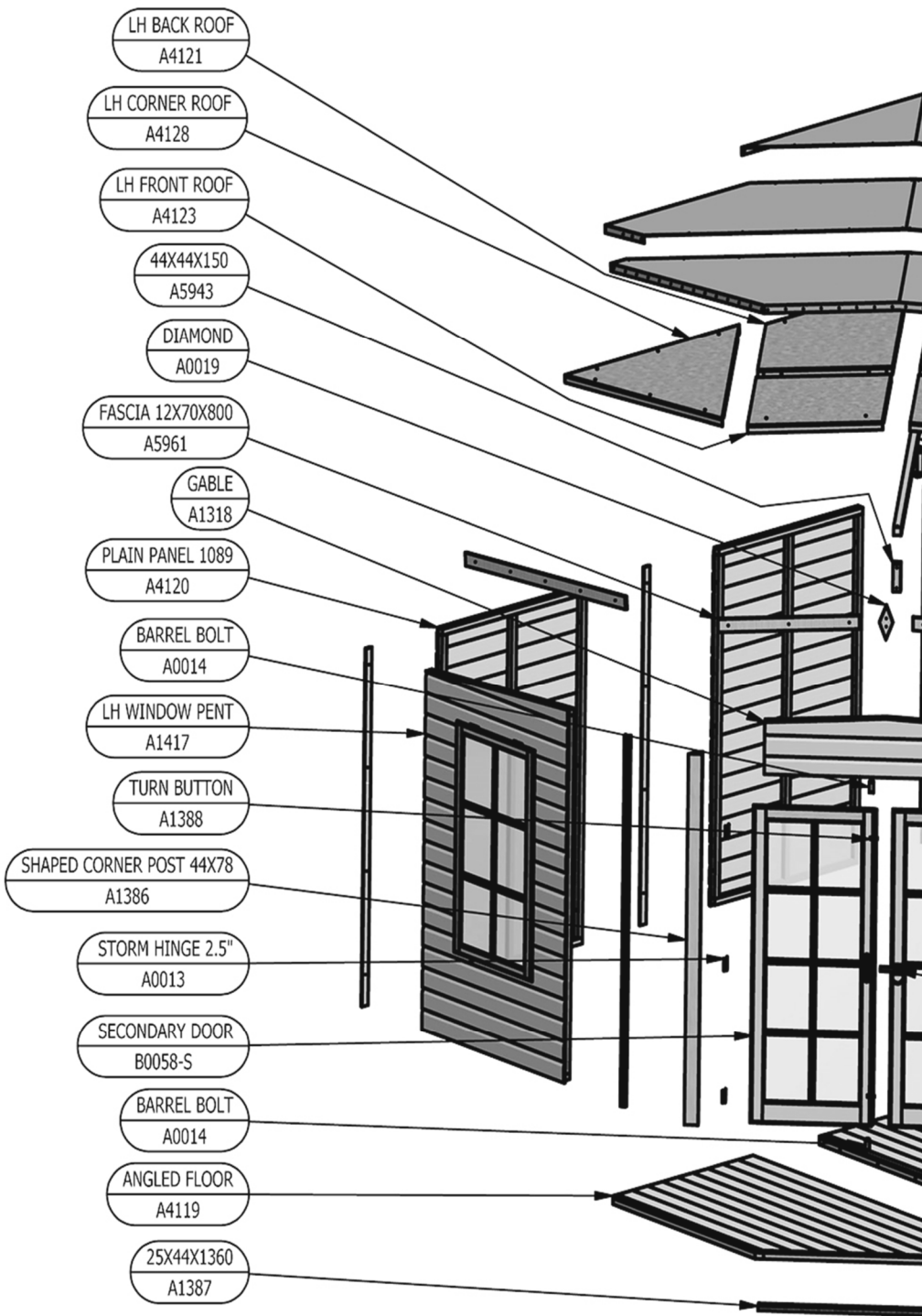

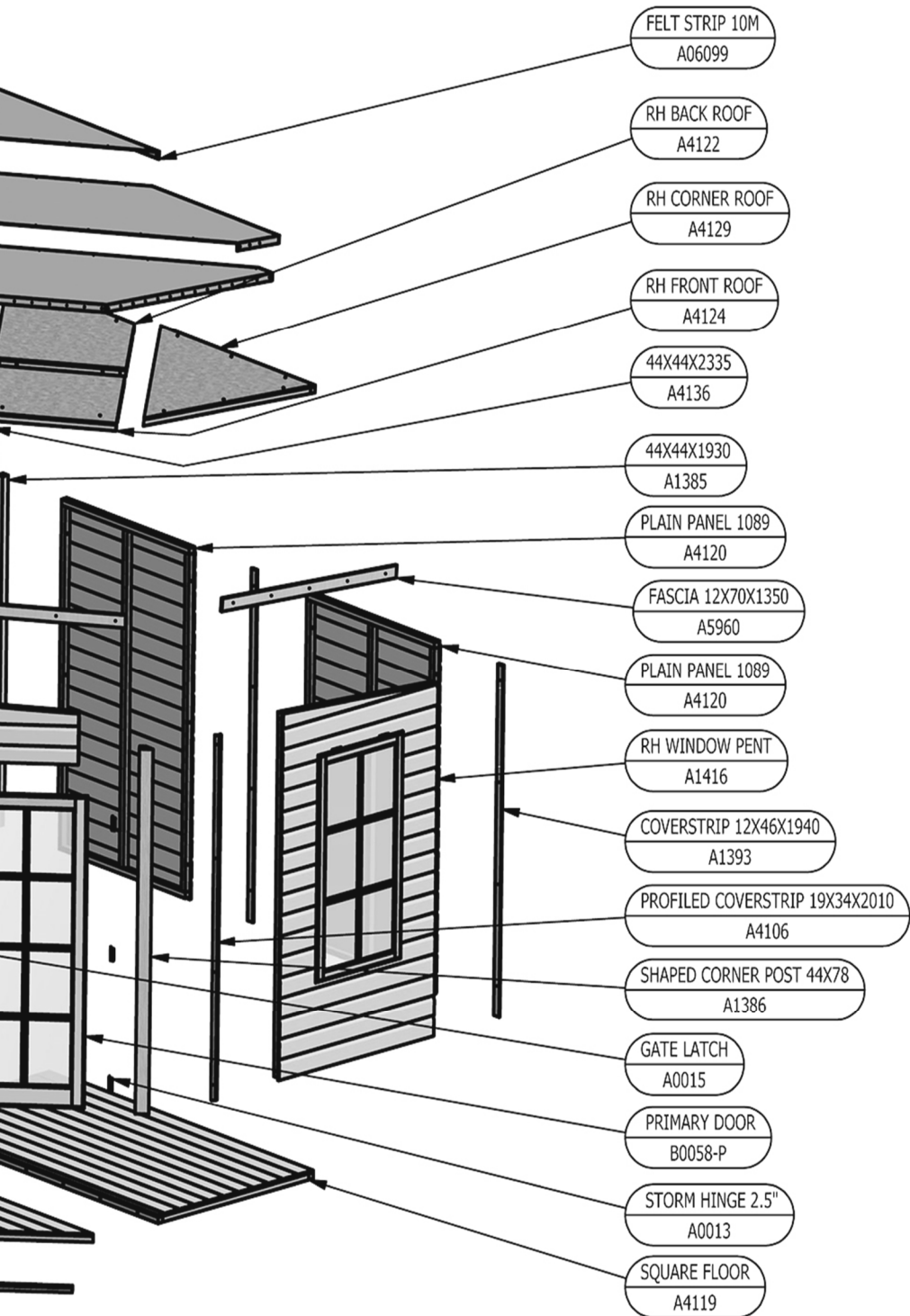

In more detail.....

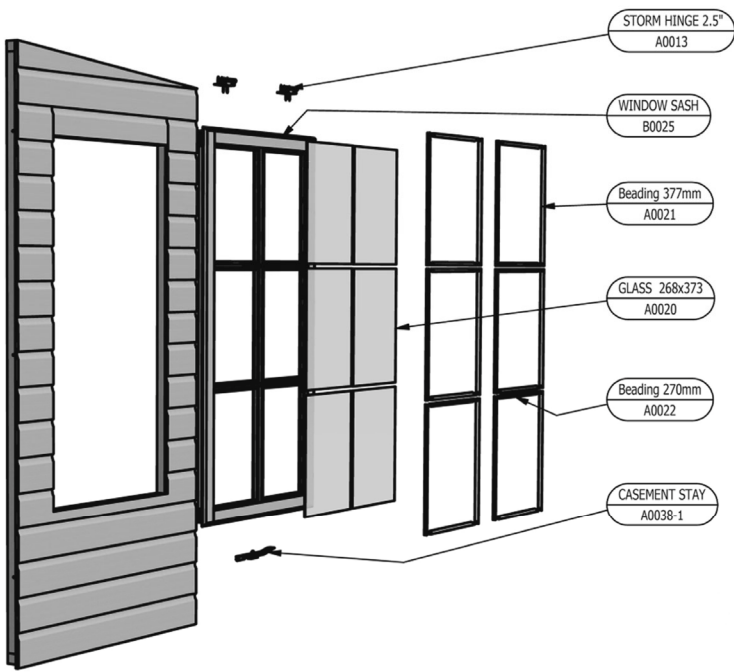

Description  
(part No ) - Qty

## Nail bag contents

### Hardware Chart Scale 1:1

16mm Panel Pins  
(A0024) x 280



13mm Felt Nail  
(A0023) x 150

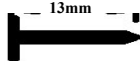

40mm Round Head Nail  
(A0025) x 72

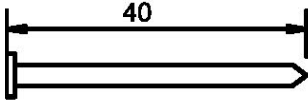

Black 25mm Posi-Drive Screw  
(A0029) x 12

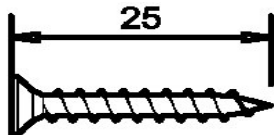

25mm Posi-Drive Screw  
(A0032) x 90

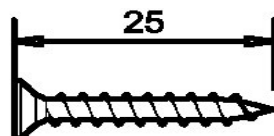

60mm Posi-Drive Screw  
(A0035) x 75

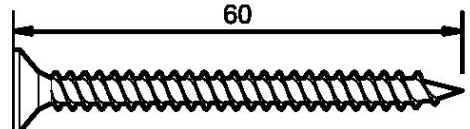

## Before you start...

## Things to check before you start:

- ✓ Ensure your base is ready – See page 4.
- ✓ Check all parts as listed in the parts lists.
- ✓ Read the instructions fully before starting work.
- ✓ Follow all the health and safety guidelines.



**When you see the drill icon**  
Only ever drill through the first piece of framework which will be a pilot hole for the screw to attach the second piece of framework  
**The required drill bit size is shown with the icon.**

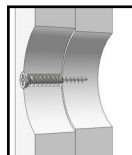
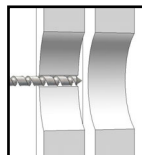

## You will need:



- Hammer

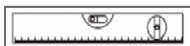

- Spirit level



- Ladder

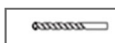

- 1mm + 5mm drill bit



- Drill

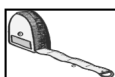

- Tape measure & Ruler

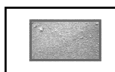

- Sand paper



- Gloves



- Saw

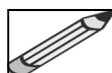

- Pencil



- Goggles

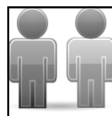

- A helper for some tasks

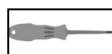

- Screwdriver



- Sharp knife



- Masking tape

# Assembly instructions:

These instructions are for your safety. Please read through them thoroughly before use.  
Treat all the parts before assembly – see page 5!

GB-IE The “Panel layout” is showing you how to position the panels.

**The Plain Panels FIT INSIDE THE WINDOW PANELS!**

01

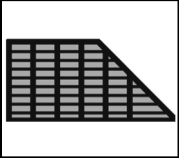
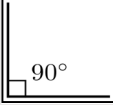

Angled Floor  
(A4119)x01

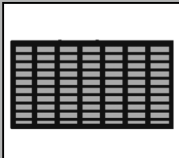

Square Floor  
(A4119)x01

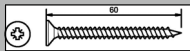

60mm Screws  
(A0035)x07

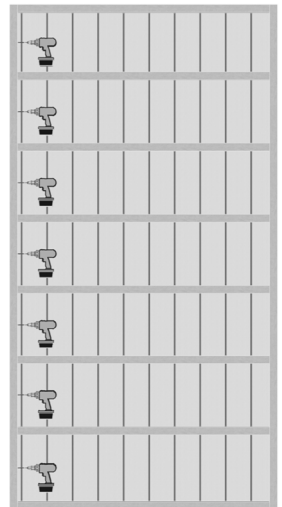
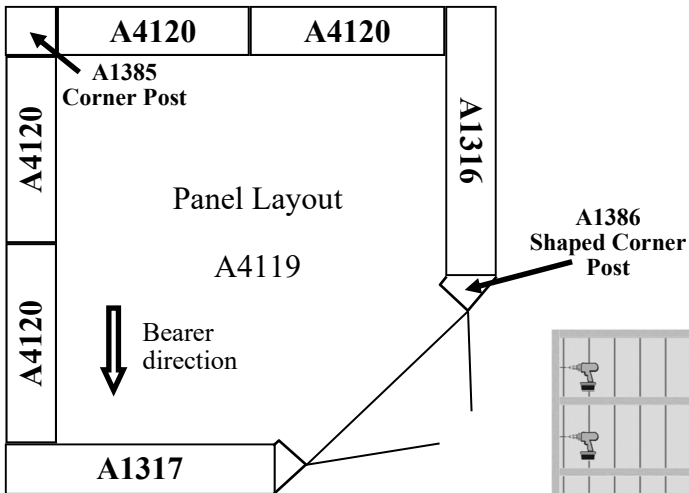

GB-IE

Drill the **Square Floor (A4119)** as above.  
Fix it to the other **Angled Floor (A4119)** using 7x **60mm Screws (A0035)**.  
Carefully turn over the Floor and put it on your base.

12

GB-IE

Fix two **2.5" Storm Hinges (A0013)** to each **Window Sash (B0025)** as below. Fix with **2x 25mm Screws (A0032)** in each hinge. Then, using a helper, hang the windows within the **Window Pents (A1416+A1417)**. Before screwing all the screws, check the window opens and closes and is in the correct position. Fix with **25mm Screws (A0032)**.

Fit the **Casement Stay (A0038)** and pins as below. Use **6x 25mm Screws (A0032)**. Make sure the locations pins work correctly by opening and closing the window.

02

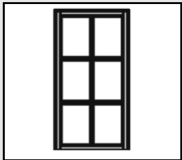
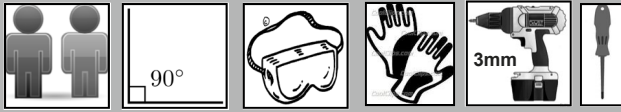

Window Sash (B0025)x02

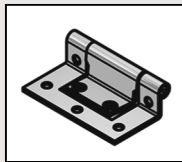

2.5" Storm Hinge (A0013)x04

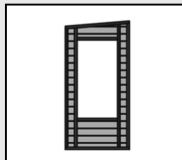

RH Window Pent (A1416)x01

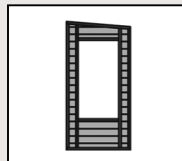

LH Window Pent (A1417)x01



Casement Stay (A0038)x02

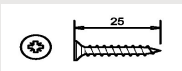

25mm Screws (A0032)x40

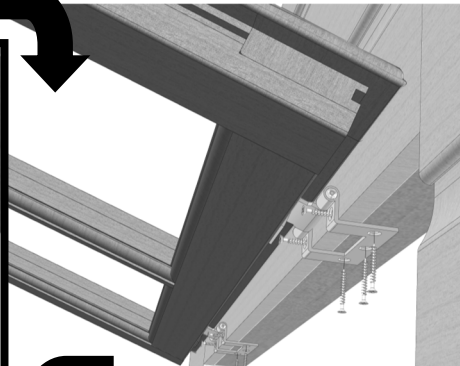
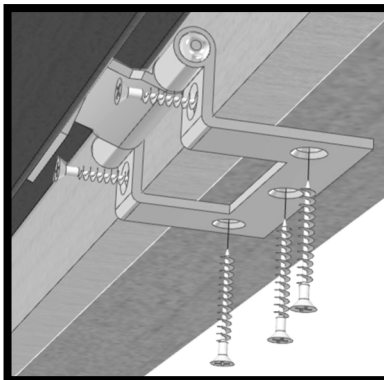
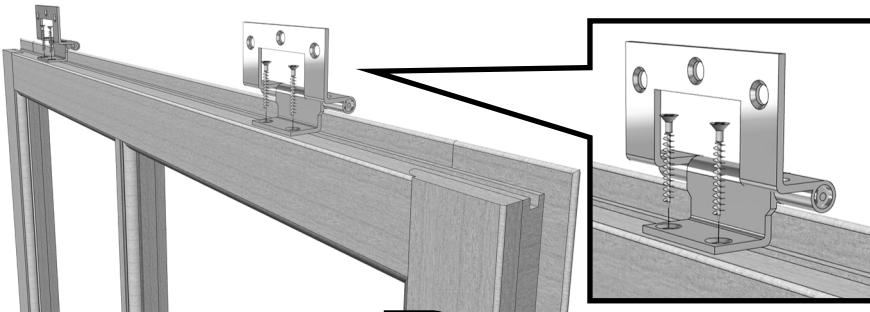

TEST WINDOW OPENS AND CLOSSES

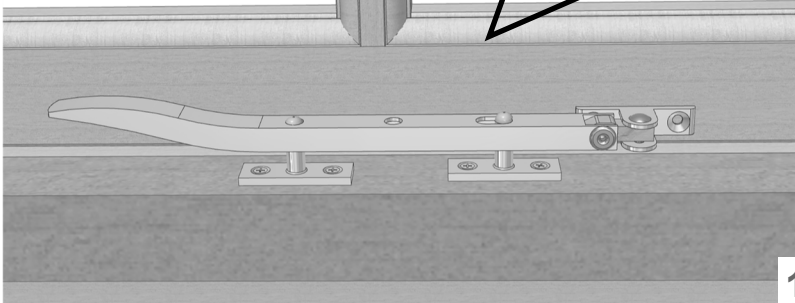
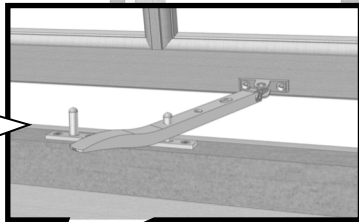

Drill one **Plain Panel 1089 (A4120)** as below.  
 GB-IE Place the **44x44x1930 (A1385)** into the corner of the floor. Push the Plain Panel up to the post and fix with 3x **60mm Screws (A0035)** using the pilot holes drilled.

03

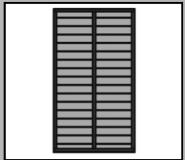

Plain Panel 1089 (A4120)x01

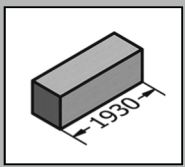

44x44x1930 (A1385)x01

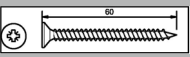

60mm Screws (A0035)x03

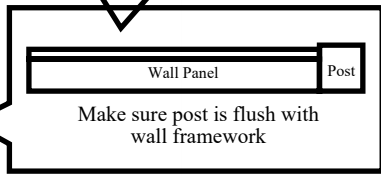
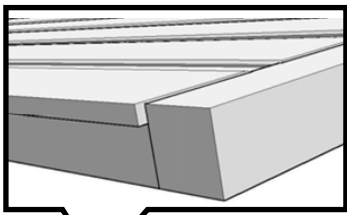
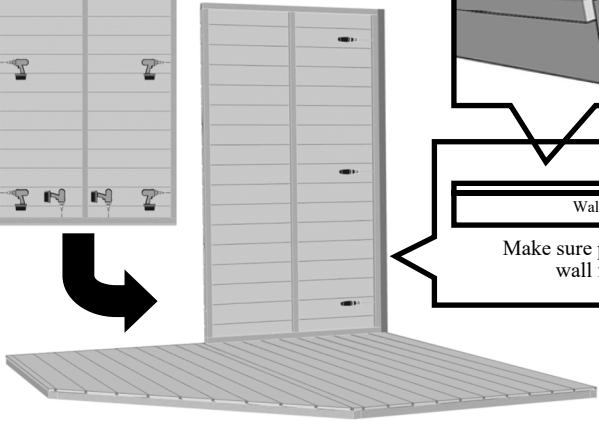
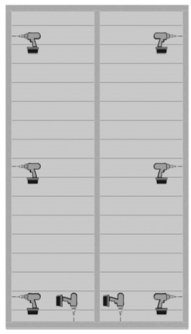

Make sure post is flush with wall framework

DO NOT FIX WALLS TO FLOOR UNTIL ASKED

GB-IE

Drill another **Plain Panel 1089 (A4120)** as below.  
 Fix to the 44x44x1930 frame using 3x **60mm Screws (A0035)**.  
**NOTE:** Post will should no longer be visible once panels are fixed.

04

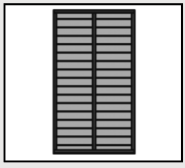

Plain Panel 1089 (A4120)x01

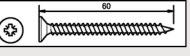

60mm Screws (A0035)x03

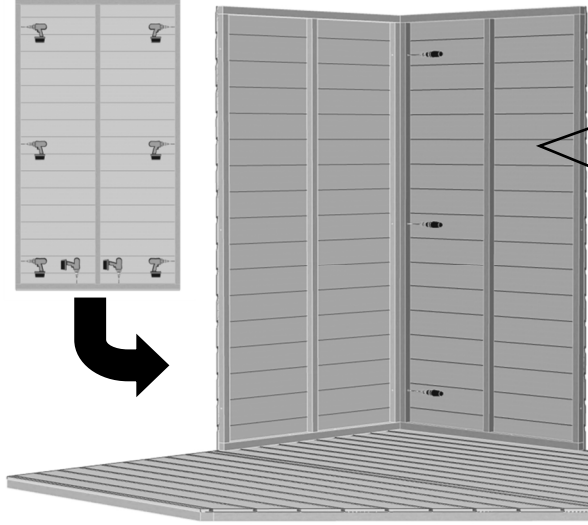
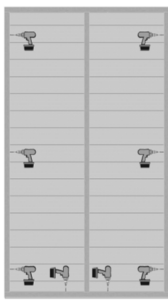

FIX TO 44X44X1930 FRAME

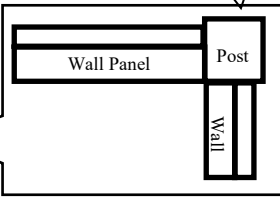

POST WILL NO LONGER BE VISABLE ONCE PANEL IS SCREWED TO IT

DO NOT FIX WALLS TO FLOOR UNTIL ASKED

GB-IE Drill a third **Plain Panel 1089 (A4120)** as below.  
Fix using 3x **60mm Screws (A0035)** using the pilot holes drilled in **Step 3**.

05

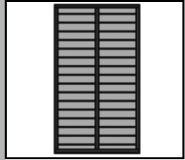

Plain Panel 1089 (A4120)x01

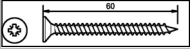

60mm Screws (A0035)x03

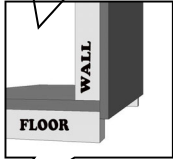
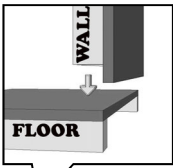
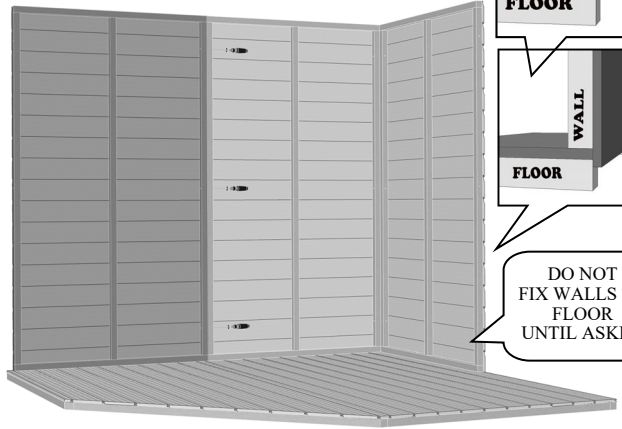

DO NOT  
FIX WALLS TO  
FLOOR  
UNTIL ASKED

GB-IE Drill the last **Plain Panel 1089 (A4120)** as below.  
Fix using 3x **60mm Screws (A0035)** using the pilot holes drilled in **Step 4**.

06

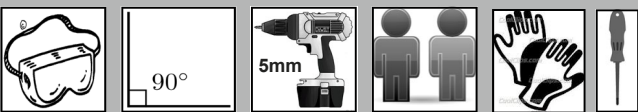

Plain Panel 1089 (A4120)x01

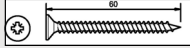

60mm Screws (A0035)x03

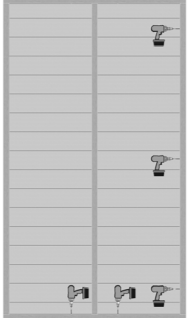

DO NOT  
FIX WALLS TO  
FLOOR  
UNTIL ASKED

GB-IE

Drill the **LH Window Pent (A1417)** as below. Make sure side holes are at an angle. Place panel into the corner of floor and secure with 3x **60mm Screws (A0035)** using the pilot holes.

07



**LH Window Pent (A1417)x01**

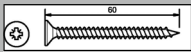

**60mm Screws (A0035)x03**

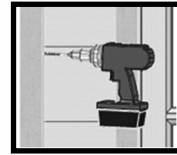
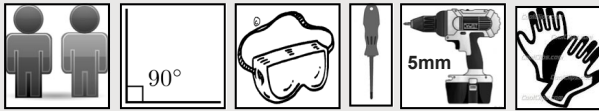

DO NOT  
FIX WALLS TO  
FLOOR  
UNTIL ASKED



**NOTE**  
Some holes  
drilled for  
later use

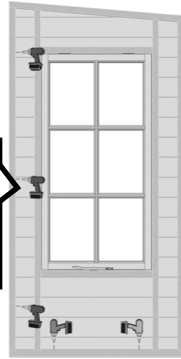

GB-IE

Drill the **RH Window Pent (A1416)** as below. Place panel into the corner of floor and secure with 3x **60mm Screws (A0035)** using the pilot holes.

08

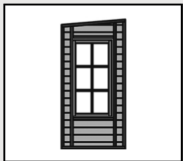

**RH Window Pent (A1416)x01**

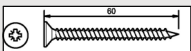

**60mm Screws (A0035)x03**

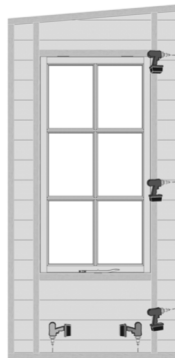
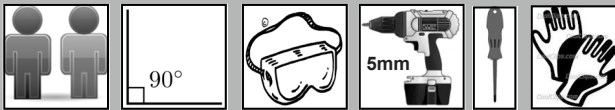

DO NOT  
FIX WALLS TO  
FLOOR  
UNTIL ASKED

16

Place the two **Shaped Corner Posts (A1386)** onto the ends of the Window Panels as below. Position the posts so that the angled edge sits against the panels. Fix with 3x **60mm Screws (A0035)** in each.

09

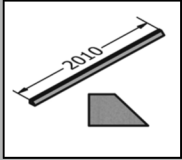
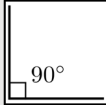

Shaped Corner Post (A1386)x02

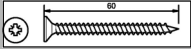

60mm Screws (A0035)x06

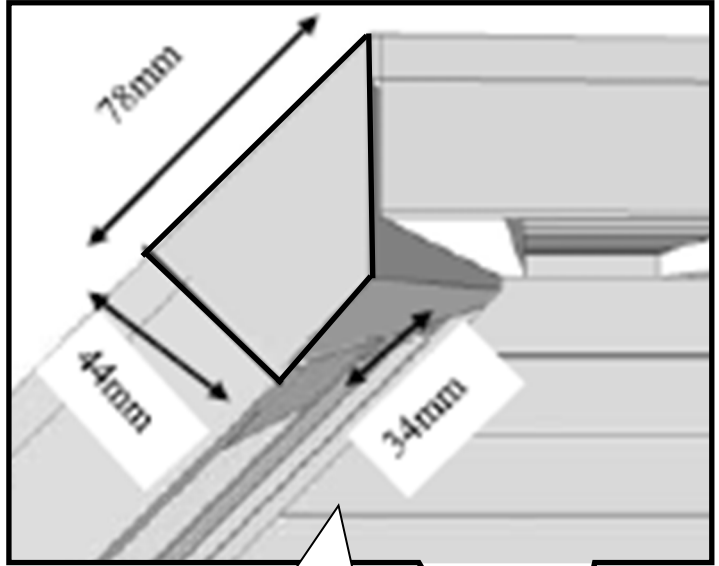

PLEASE MAKE SURE THE CORNER POSTS ARE THE CORRECT ORIENTATION BEFORE FIXING TO YOUR BUILDING

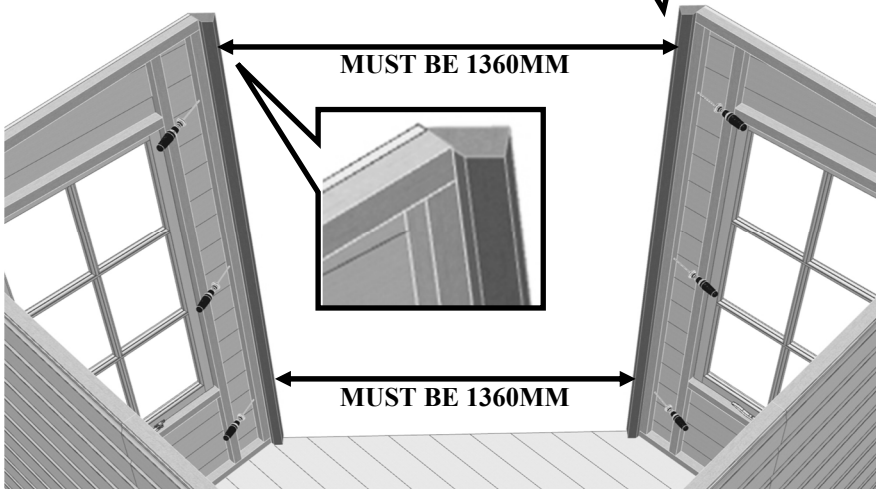

Drill the **Gable (A1318)** as below. Drill one **44x44x150 (A5943)** into the **Gable (A1318)** using the pilot holes, 44mm down from the top of top of the middle gable bar. Fix the Gable to your building as below, making sure the top of the Gable sides are flush with the top of the corner posts, using **60mm Screws (A0035)**.

10

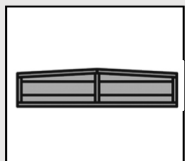

Gable (A1318)x01

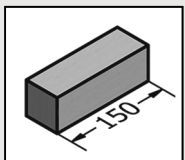

44x44x150 (A5943)x01

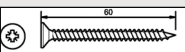

60mm Screws (A0035)x06

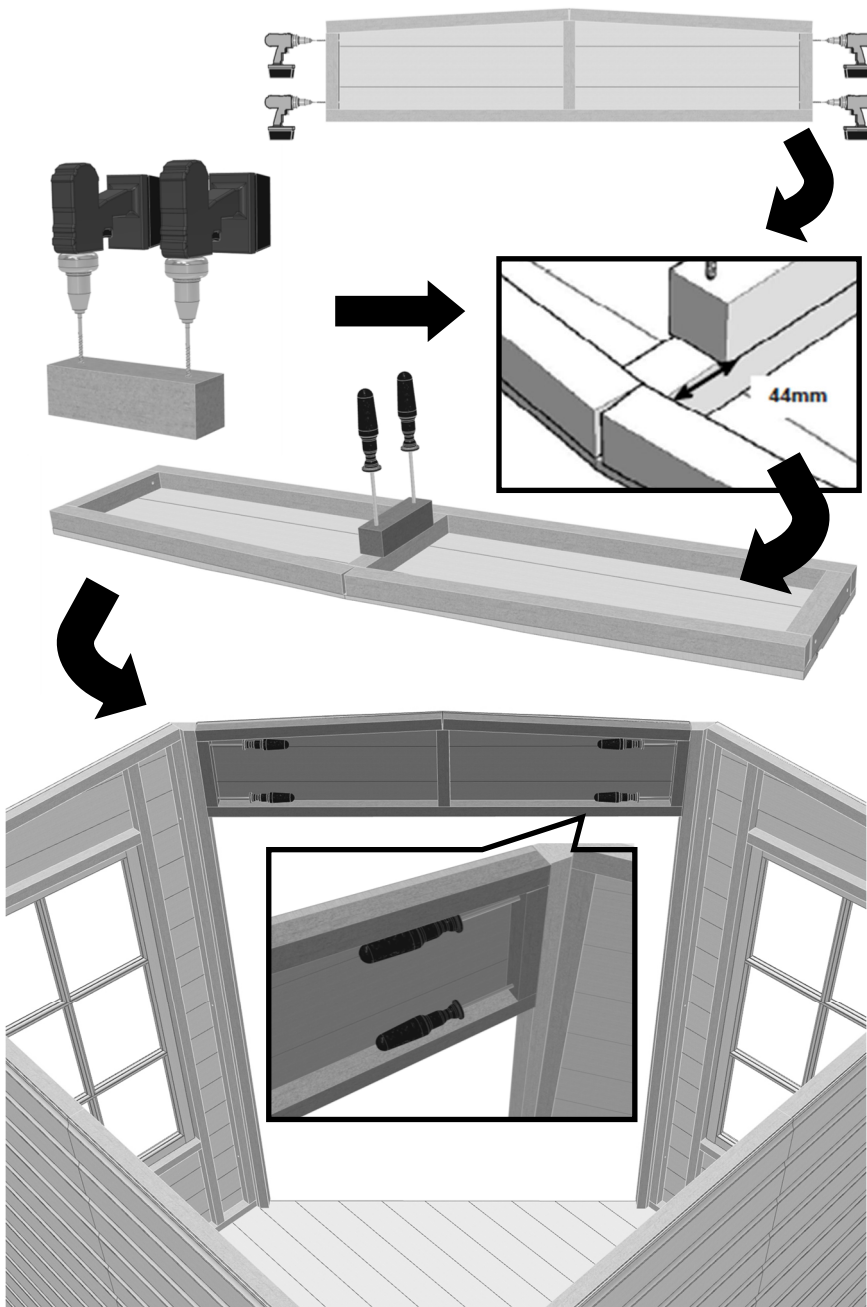

GB-IE Drill and screw the **22x45x1360 (A1387)** to the floor as below. Fix with **60mm Screws (A0035)**. Make sure the bar is flush with the corner posts and floor.

11

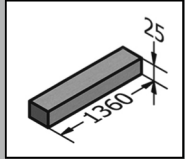
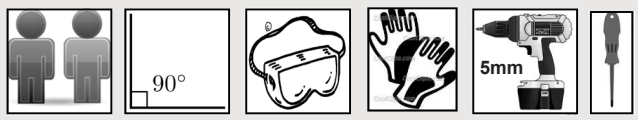

22x45x1360 (A1387)x01

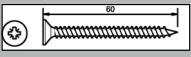

60mm Screws (A0035)x05

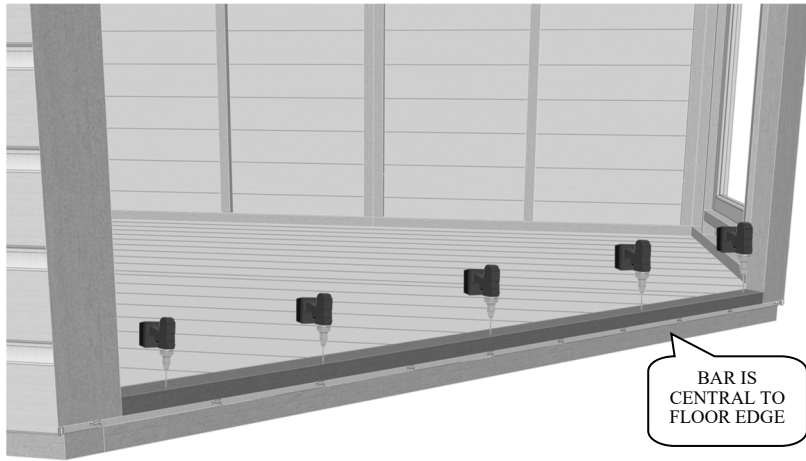

BAR IS CENTRAL TO FLOOR EDGE

GB-IE Make sure your building is square and true. Fix the walls to the floor with **60mm Screws (A0035)** using the pilot holes drilled previously.

12

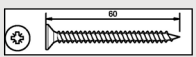
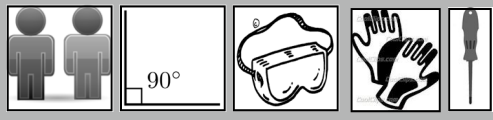

60mm Screws (A0035)x12

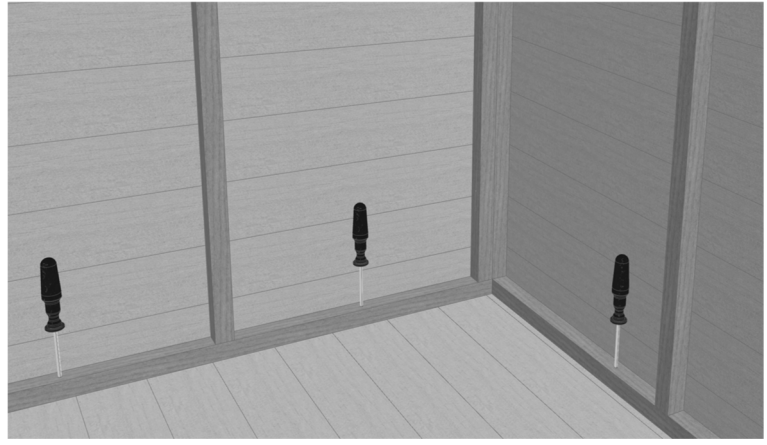

Fix the **Storm Hinges 2.5" (A0013)** to the **Primary and Slave Doors (B0058P+S)** using **25mm Screws (A0032)** as below. (Make sure to screw the two-hole part first). Hang the doors within the door aperture as below. Fix the hinges to the corner posts as below using **25mm Screws (A0032)**. **TIP:** Use packing under the door to level them out. Make sure that the primary door is the door that opens first.

13



Hampton Primary Door (B0058-P)x01



Hampton Secondary Door (B0058-S)x01

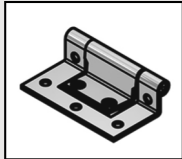

Storm Hinge 2.5" (A0013)x06

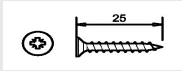

25mm Screws (A0032)x42

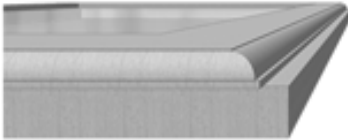
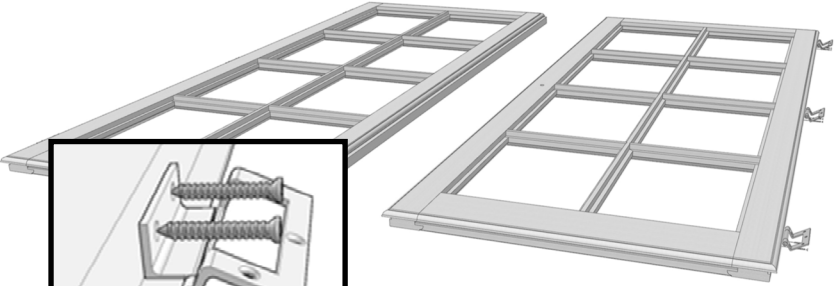

SECONDARY SLAVE DOOR



PRIMARY DOOR

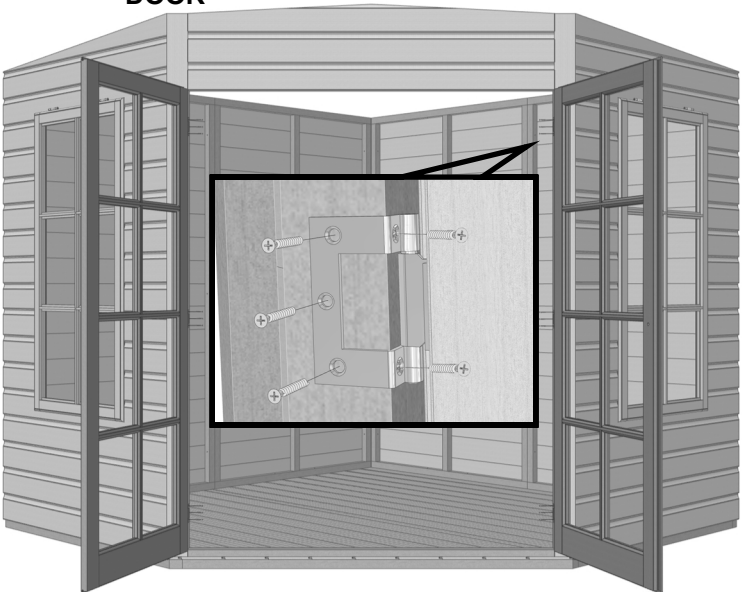

GB-IE Position the **Gate Latch (A0015)** over the **Primary Door** and mark where the holes sit. Drill the middle hole only and fit the Square shaft into the hole. Locate the two ring handles and attach the plates using **Black 25mm Screws (A0029)**.

14

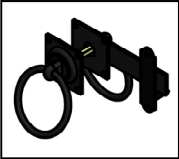
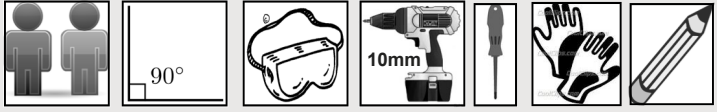

Gate Latch (A0015)x01

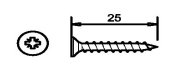

Black 25mm Screws (A0029)x10



GB-IE Fix one **Turn Button (A1388)** to the top and bottom of the **Secondary Slave Door (B0059-S)** so that they hold the primary door shut. Fix with one **25mm Screw (A0032)** in each.

15

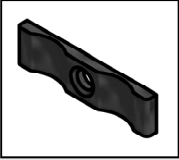
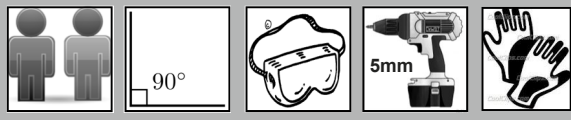

Turn Button (A1388)x02

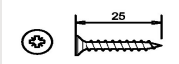

Black 25mm Screws (A0029)x02

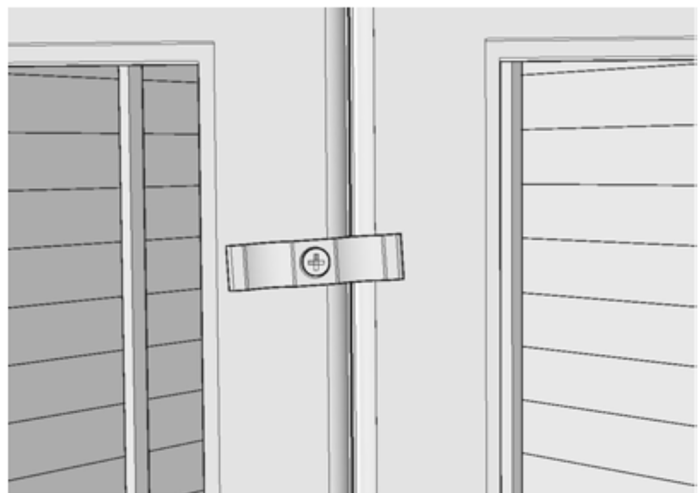

Mark and Drill a hole where the bolt will go into the framework.  
Screw the **Barrel Bolts (A0014)** to the secondary door as below. Make sure everything works before tightening screws. Fix with **25mm Screws (A0032)**. Repeat with top bolt.

GB-IE

16

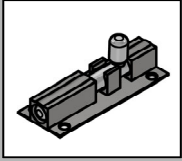

Barrel Bolt  
(A0014)x02

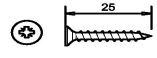

25mm Screws  
(A0032)x08

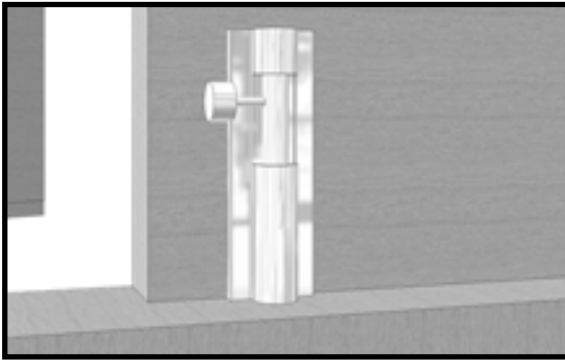
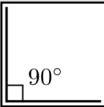

GB-IE

Drill and screw the other **44x44x150 (A5943)** to the back corner wall panels as below. Make sure it sits **78mm** down from the top of the wall panels. Fix with 2x **60mm Screws (A0035)**. Place the **44x44x2335 (A4136)** onto the blocks as below. Drill and screw into the 150mm frame bars using **60mm Screws (A0035)**.

17

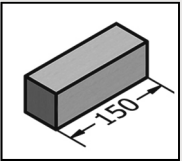

44x44x150  
(A5943)x01

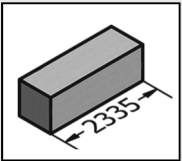

44x44x2335  
(A4136)x01

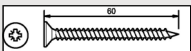

60mm Screws  
(A0035)x04

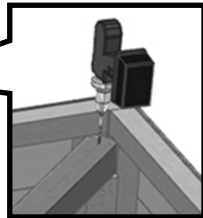
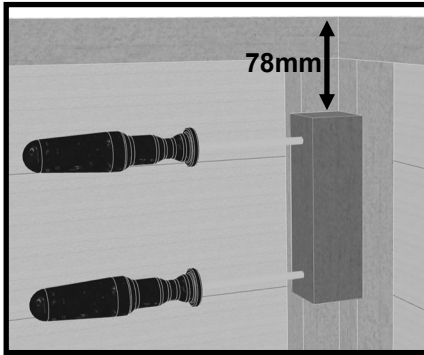
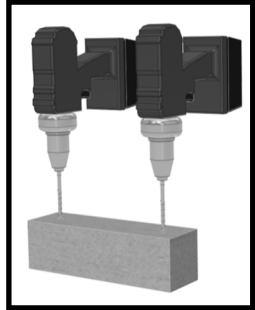
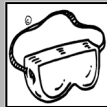
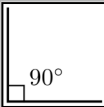

22

Drill all the Roof Panels (A4121, A4122, A4123, A4124) as below. Place the LH Front Roof (A4123) and LH Back Roof (A4121) onto your building as below, so that it rests on the roof bearer. Nail 3x 40mm Nails (A0025) along the back wall and 2 along the gable. On the inside, screw together using 2x 60mm Screws (A0035). Repeat with the LH Corner Roof (A4128). Fix with 6x 40mm nails on the top and 4 x 60mm screws on the inside as below.

GB-IE

18

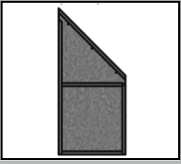

LH Back Roof (A4121)x01

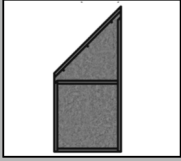

RH Back Roof (A4122)x01

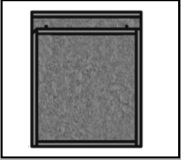

LH Front Roof (A4123)x01

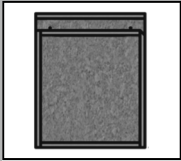

RH Front Roof (A4124)x01

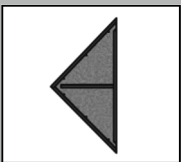

LH Corner Roof (A4128)x01

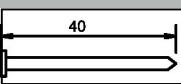

40mm Nails (A0025)x11

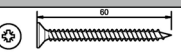

60mm Screws (A0035)x06

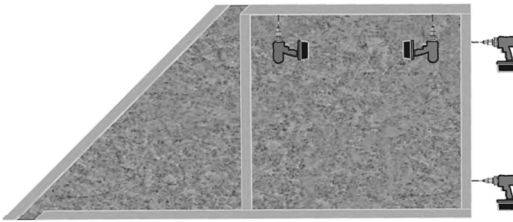

LH BACK ROOF

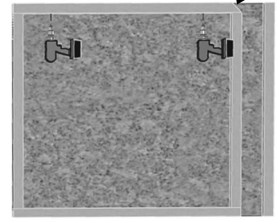

LH FRONT ROOF

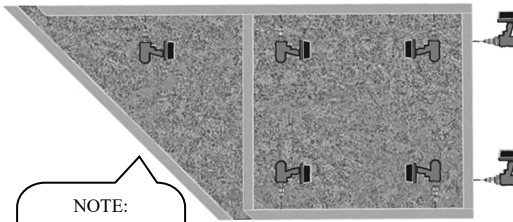

RH BACK ROOF

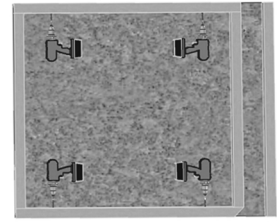

RH FRONT ROOF

NOTE:  
THE ANGLED  
PIECES IN  
EACH ROOF  
PANEL

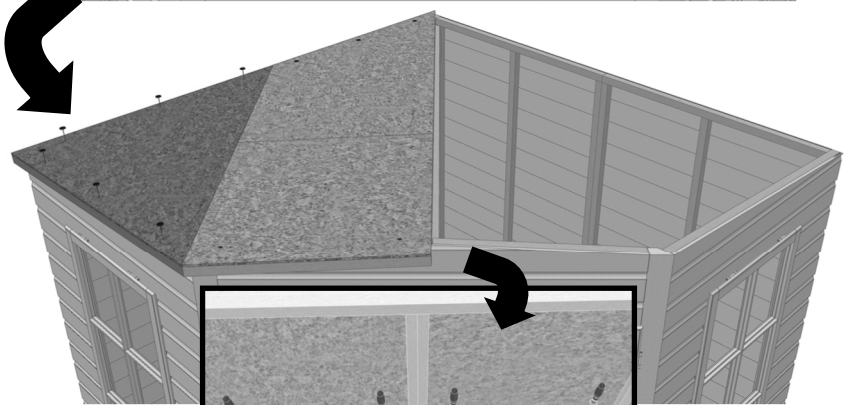
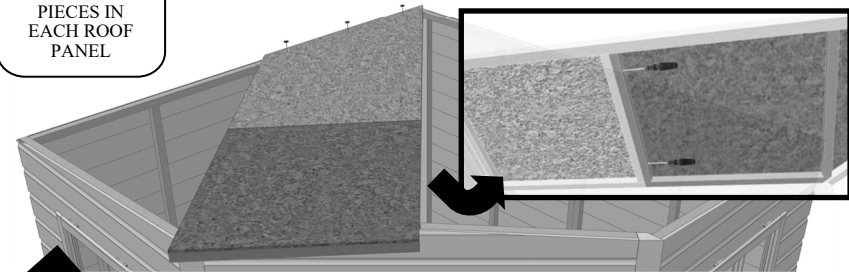

Repeat the previous step for the **RH Front Roof (A4124)** and the **RH Back Roof (A4122)**.

**\*\*\*chamfered edges should sit against the wall panels of your building\*\*\***

Fix the **RH Corner Roof (A4129)** as you did with the left hand side.

Fix with **40mm Nails (A0025)** and **60mm Screws (A0035)**.

19

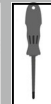
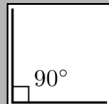

Use pilot holes drilled in Step 18

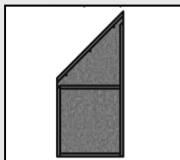

RH Back Roof (A4122)x01

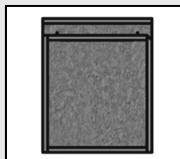

RH Front Roof (A4124)x01

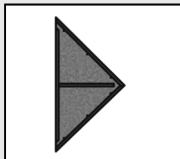

RH Corner Roof (A4129)x01

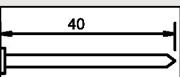

40mm Nails (A0025)x11

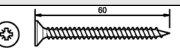

60mm Screws (A0035)x11

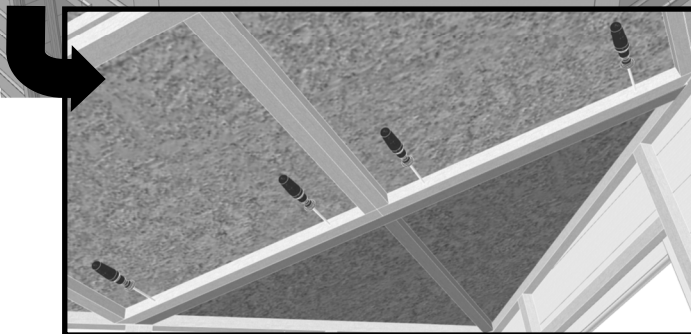
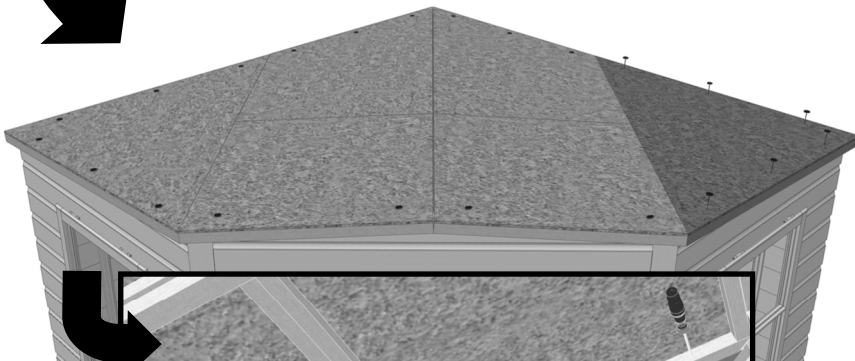
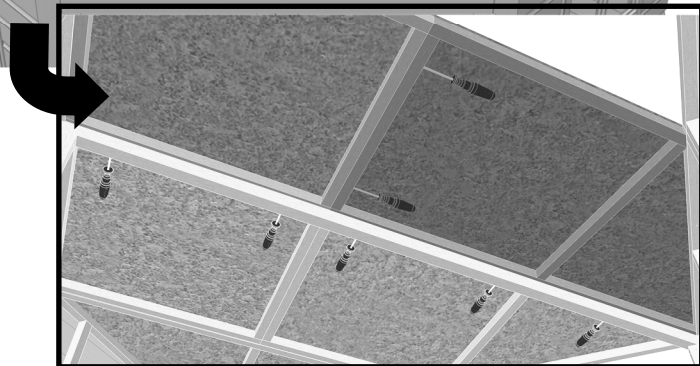
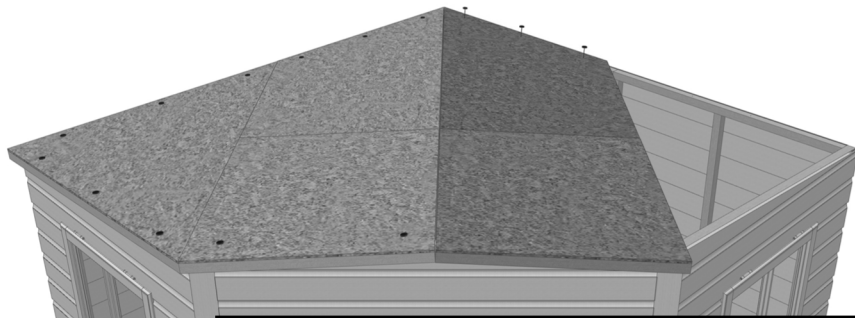

GB-IE Fit the two **Profiled Coverstrips 2010 (A4106)** to the front corners of your building. Fix with 8x **40mm Nails (A0025)** in each. Fit the four **Coverstrips 12x46x1940 (A1393)** to the back sides of your building as below. All four to be nailed with 4x **40mm Nails (A0025)** in each.

20

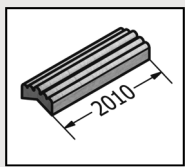

Profiled Coverstrip 2010 (A4106)x02

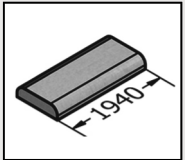

Coverstrip 12x46x1940 (A1393)x04

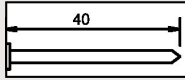

40mm Nails (A0025)x32

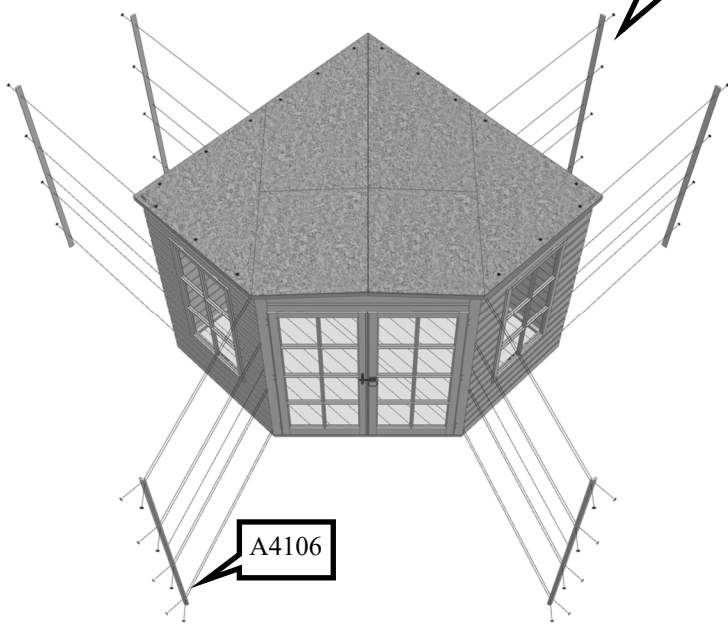
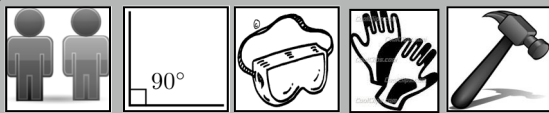

21

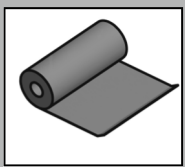

10m Felt Strip (A06099)x01

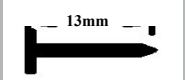

13mm Felt Nails (A0023)x38

GB-IE 1 strip of **10m Felt (A06099)** has been supplied. Roll the felt over the back corner and cut enough to cover as below. Put the rest of the felt aside. Fit to the back corner of your building as below. Make sure there is an even overhang either side, pull tight and secure with **13mm Felt Nails (A0023)** approximately 100mm apart.

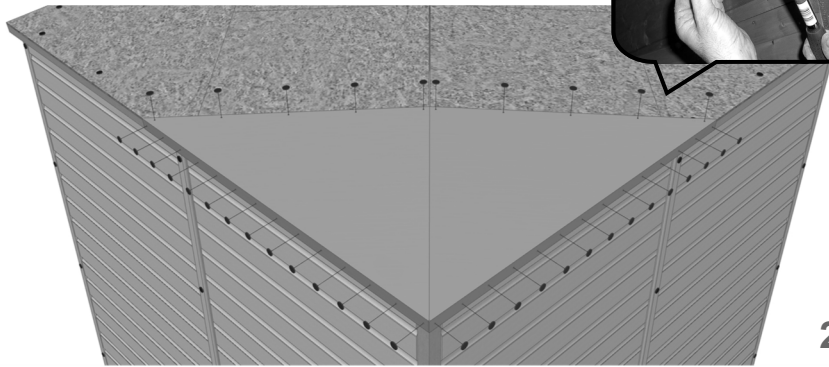
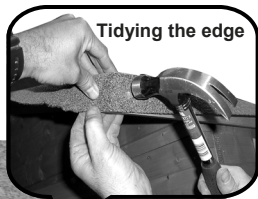
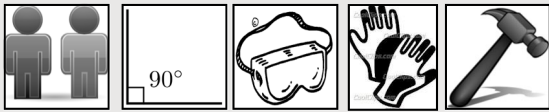

Cut the remaining felt into 2 equal strips. Fit to the middle and front of your building as below. Make sure there is an even overhang, pull tight and fix with **13mm Felt Nails (A0023)** approximately 100mm apart.

22

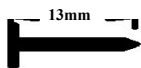
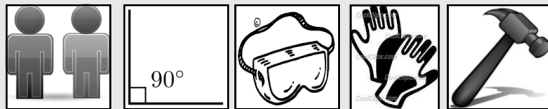

13mm Felt Nails (A0023)x112

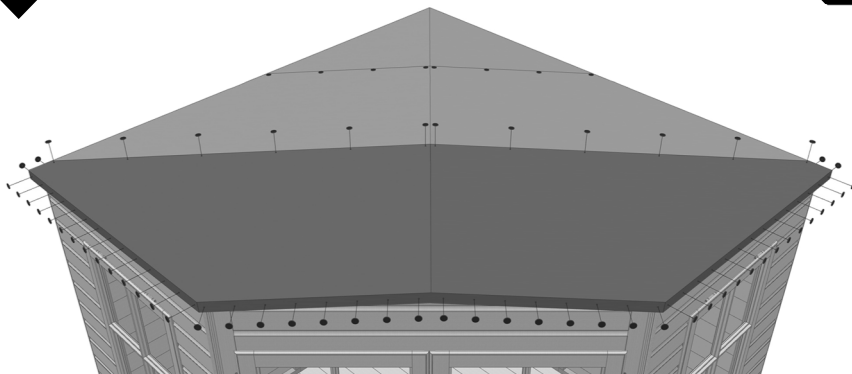
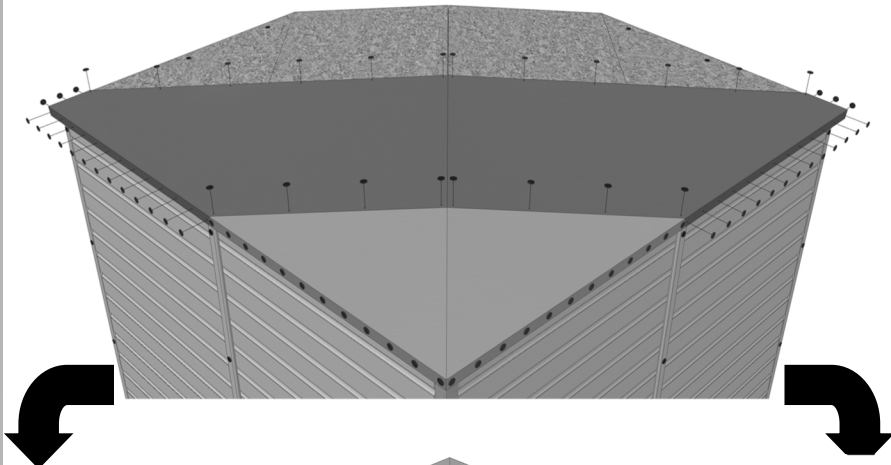

**CUT ANY EXCESS FELT IF NECESSARY**

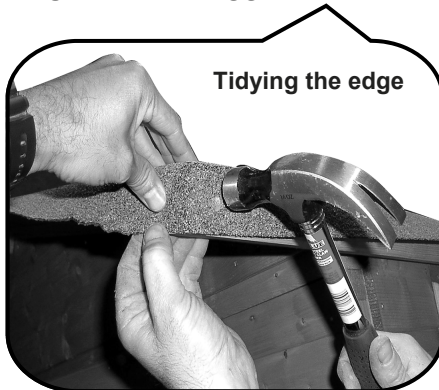

Fix the **Fascia 12x70x1300 (A5960)** to the sides and the **Fascia 12x70x800 (A5961)** to the front of your building. Then fix the **Diamond (A0019)** to the middle. Use **40mm Nails (A0025)**.

GB-IE

23

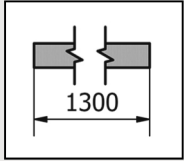
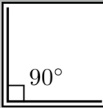

Fascia 12x70x1300  
(A5960)x02

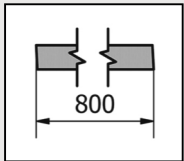

Fascia 12x70x800  
(A5961)x02

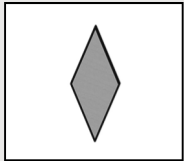

Diamond  
(A0019)x01

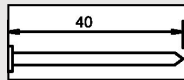

40mm Nails  
(A0025)x18

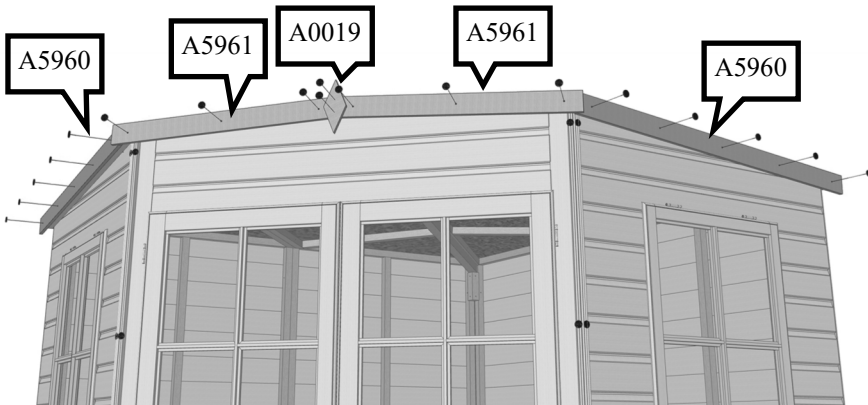

## Building Photographs

It will be greatly appreciated if you could forward images of your completed building to -

[sales@shiregb.co.uk](mailto:sales@shiregb.co.uk).



**GLASS HANDLE WITH CARE, DANGER OF CUTTING**

Using a helper, hold the **Glass 268x373(A0020)** in place. Nail the **Beading 270mm (A0022)** at the top and bottom with 2 pins in each. Nail the **Beading 377mm (A0021)** with 3 pins to the sides. Use **16mm Panel Pins (A0024)**.



24

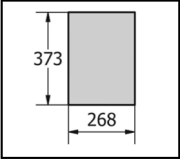
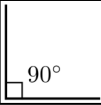

**Glass 268x373 (A0020)x28**

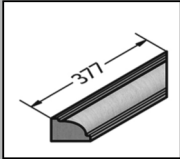

**Beading 377mm (A0021)x56**

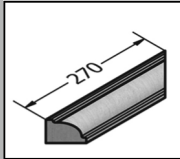

**Beading 270mm (A0022)x56**

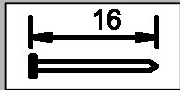

**16mm Panel Pins (A0024)x280**



**NOTE:**  
USE  
WATERPROOF  
SILICONE  
SEALANT  
BEFORE FIXING  
THE BEADING IN  
PLACE

