

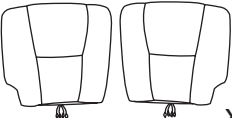









A  x1	B  x2	C  x2	D  x2	E  x2
Left & Right Backrest	Left & Right Seat Base	Left & Right Armrest	Massage Remote	Seat Iron Sheet
F   x1	G    x8	H  x2	I  x2	J  x4
Wrench	Screw & Washer	Power Cord	Power Adapter	Base Feet

STEP 1

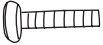
Install the 2 x Part **E** on one of the bases (**B**), just screw it up a bit, no need to lock, keep the iron sheet (**E**) in a horizontal position.

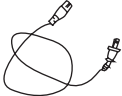
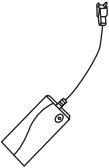
NOTE: The Part **E** needs to be installed on the iron frame, not under the iron frame.

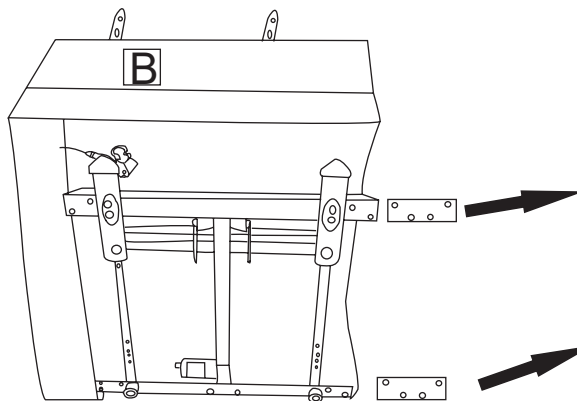

STEP 2

Make sure that the armrest is fully aligned with the groove when inserting it, and then press down firmly until you hear a "click" sound to complete.

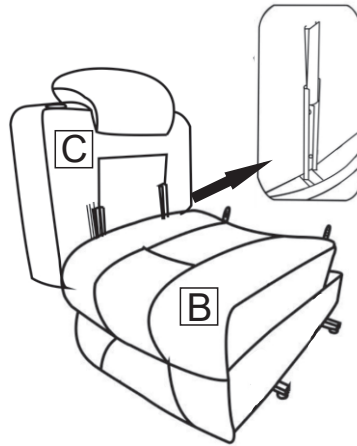

STEP 3

Make sure that the backrest is fully aligned with the grooves on the left and right sides when inserting, and then press down firmly until you hear a "click" sound.

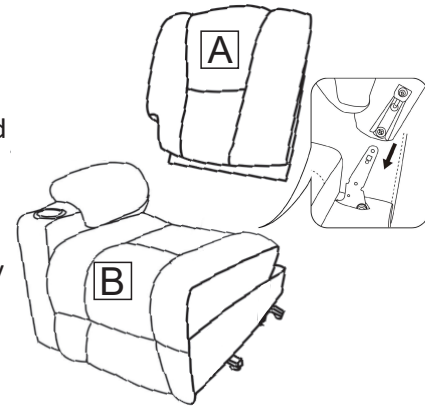

STEP 4

Make sure that the armrest is fully aligned with the groove when inserting it, and then press down firmly until you hear a "click" sound to complete.

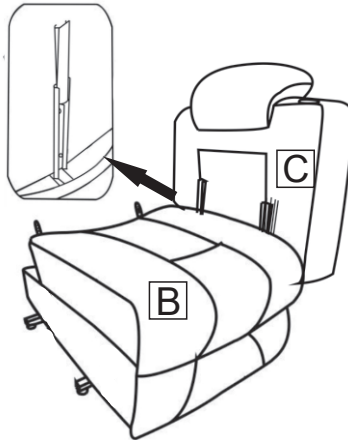

STEP 5

Make sure that the backrest is fully aligned with the grooves on the left and right sides when inserting, and then press down firmly until you hear a "click" sound.

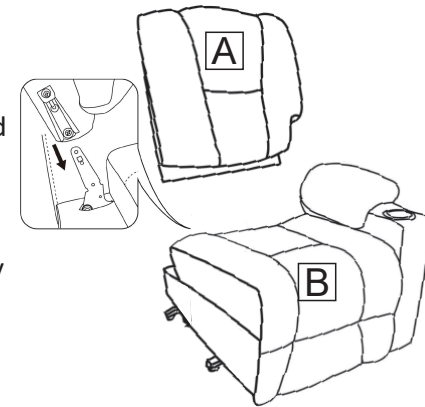

STEP 6

Fix the two bases with Part E.

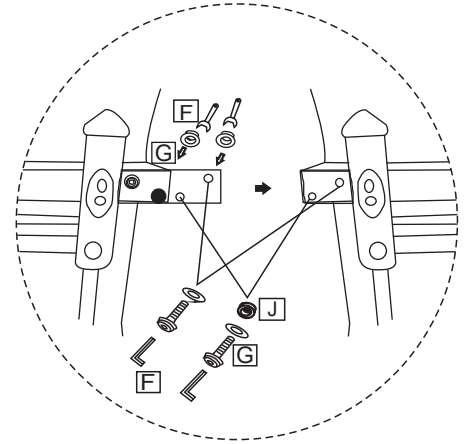
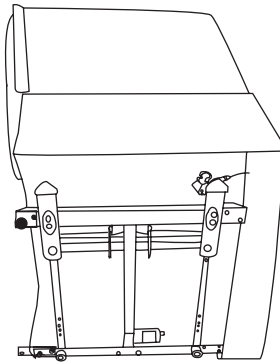
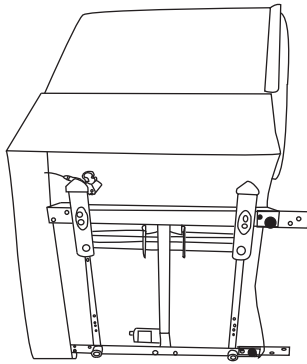

STEP 7

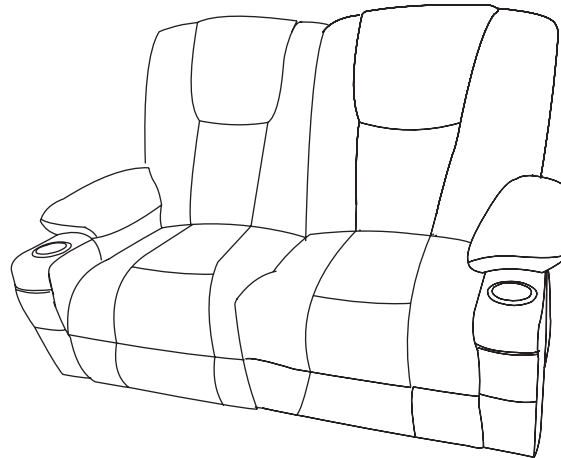

Connections Instructions

- No.1, No.2 and No.3** wires from the backrest and chair base with same color connect together.
- No.4** wire from the back connects to the massage remote
- No.5** wire from the bottom of the sofa connects to the power adapter.
- No.6** wire from the bottom of the armrest connects to the wire at the bottom of the sofa.

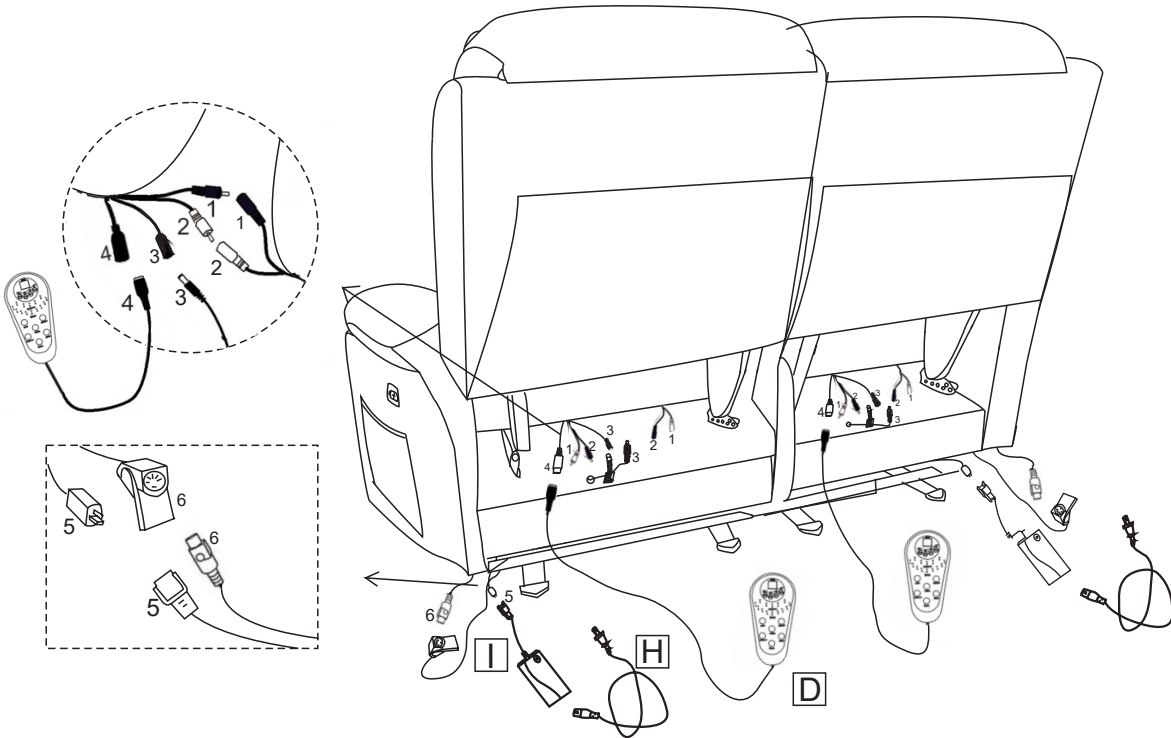

How to recliner?

Press and hold the button near the USB interface, and then the footrest starts to release. When reaching a certain height, the backrest starts to lie down until the maximum angle.

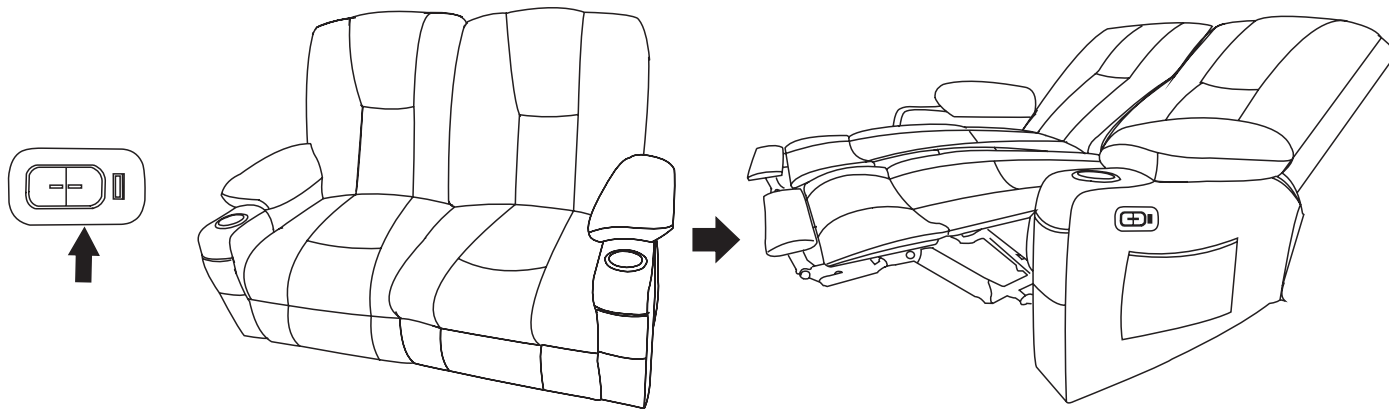

How to get footrest latch down?

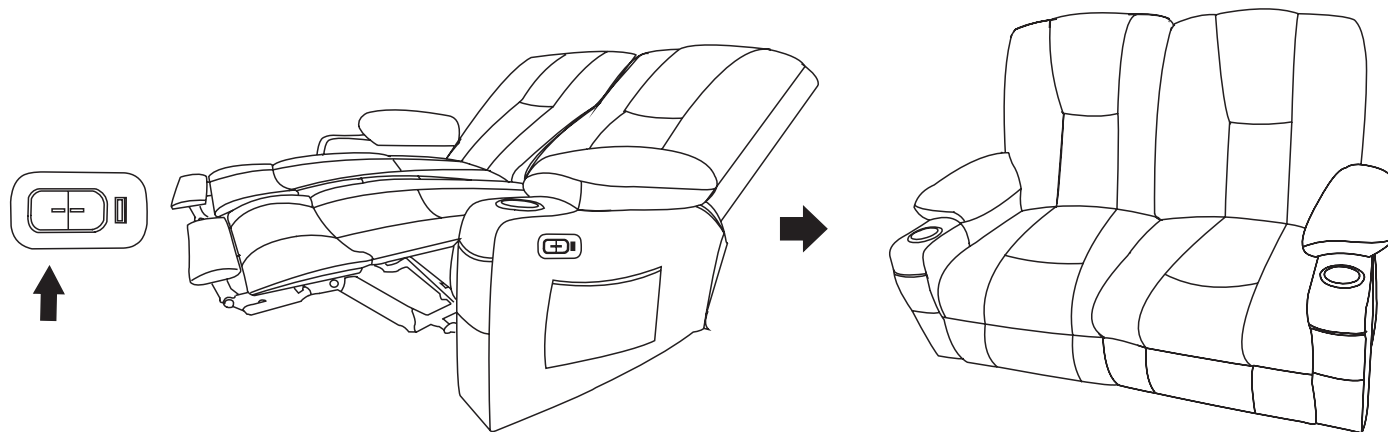

How to use remote control?

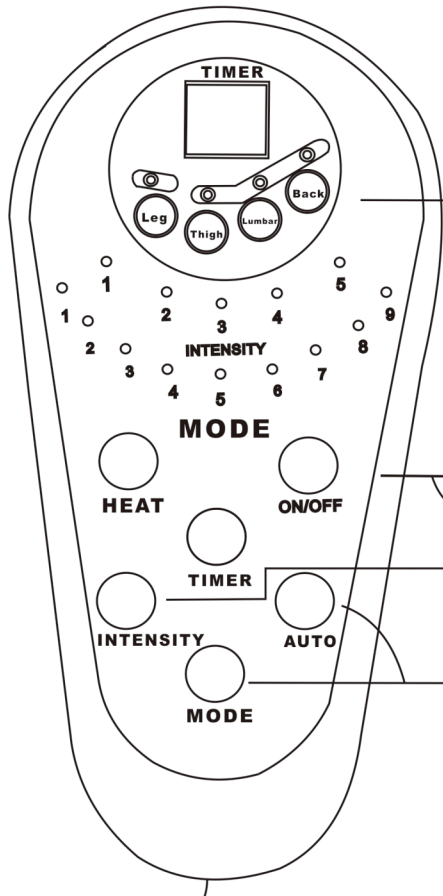

You can choose 1-4 massage parts(back,lumbar,thighs,legs)to enjoy

How to Only Keep The Heat Work: Turn on the massage and heat firstly, and then press one of the 4 buttons(back, lumbar, thigh, leg) twice, then the massage will be turned off.

ON/OFF:Turn on/off remote control

HEAT:Turn on/off heat function for lumbar part only

INTENSITY:Control massage funcion from low to high

MODE:Choose one massage mode you like(pulse,press,wave,au-to,normal)