

Maximum capacity : 110 kgs/242 Lbs

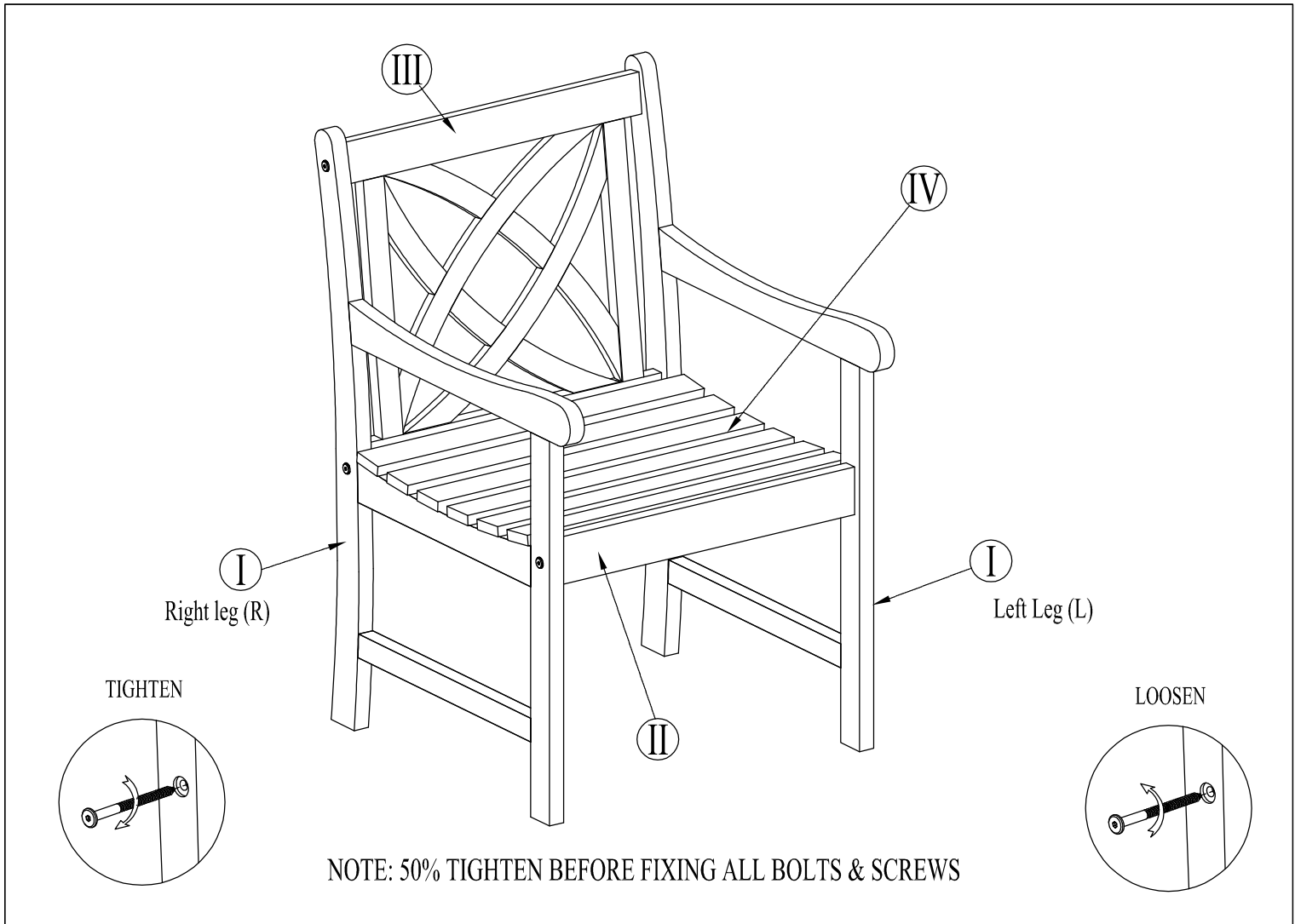



COMPONENTS LIST

<p style="text-align: center;">Right leg (R) Left Leg (L)</p> <p style="text-align: center;">Q'TY 2</p>	<p style="text-align: center;">Q'TY 1</p>	<p style="text-align: center;">Q'TY 1</p>
<p style="text-align: center;">Q'TY 1</p>		

HARDWARE LIST

A		6	Screw 7 x 70				
B		2	Screw 7x40	C		2	Allen Key

Step 1

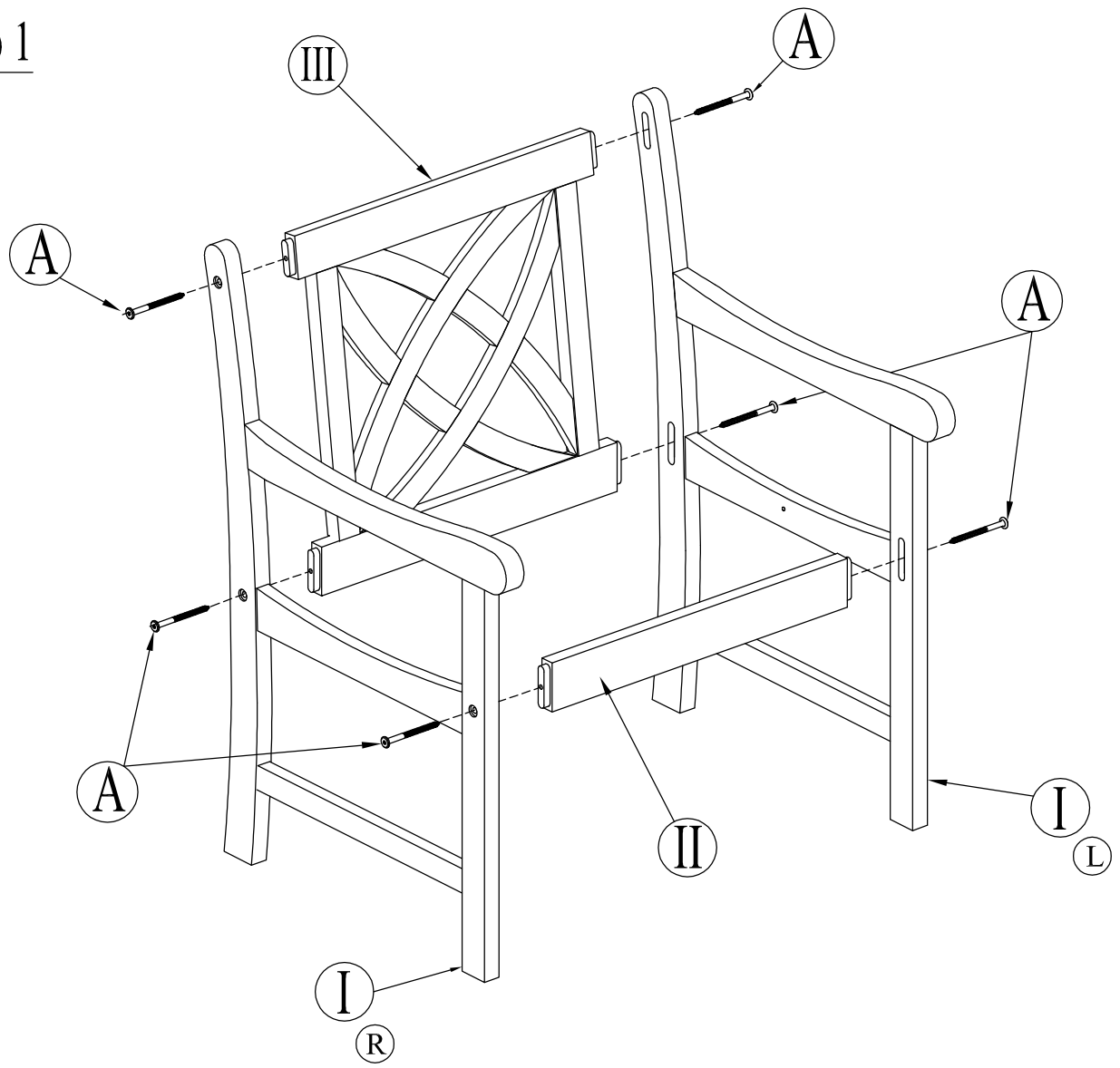

Step 2

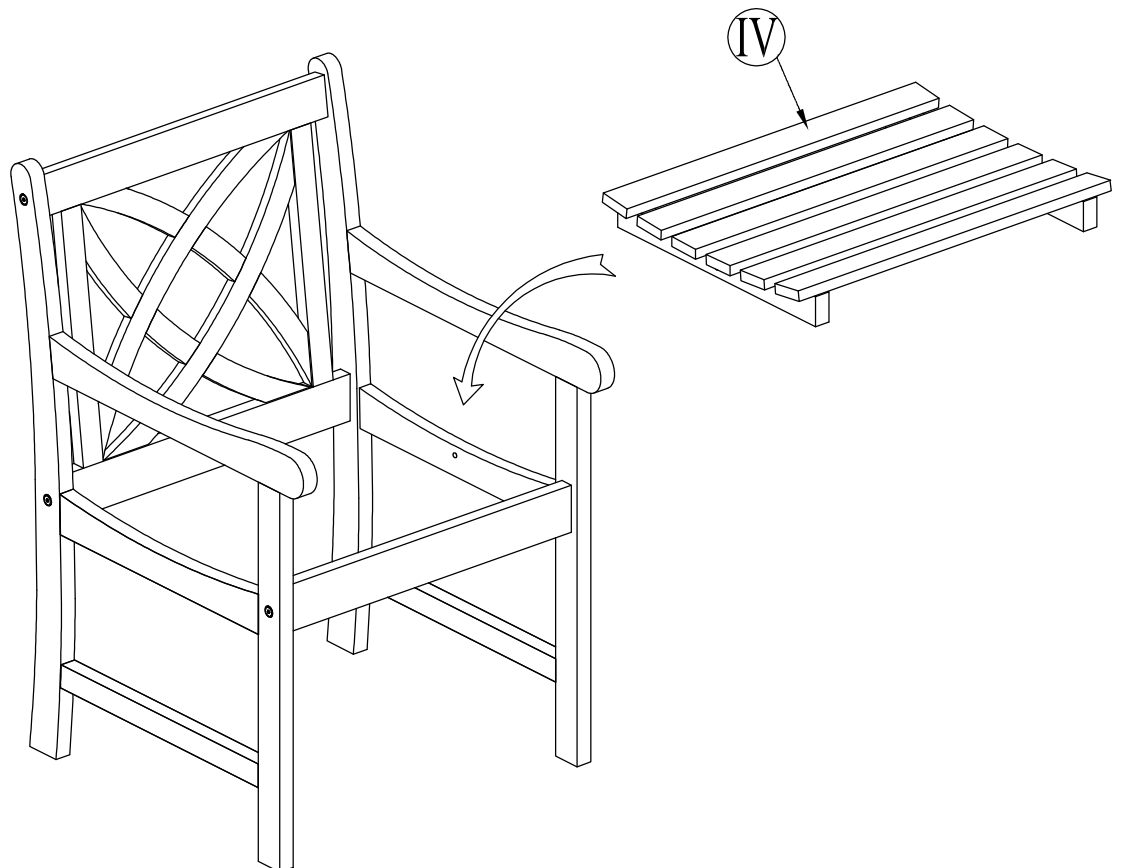

Step 3

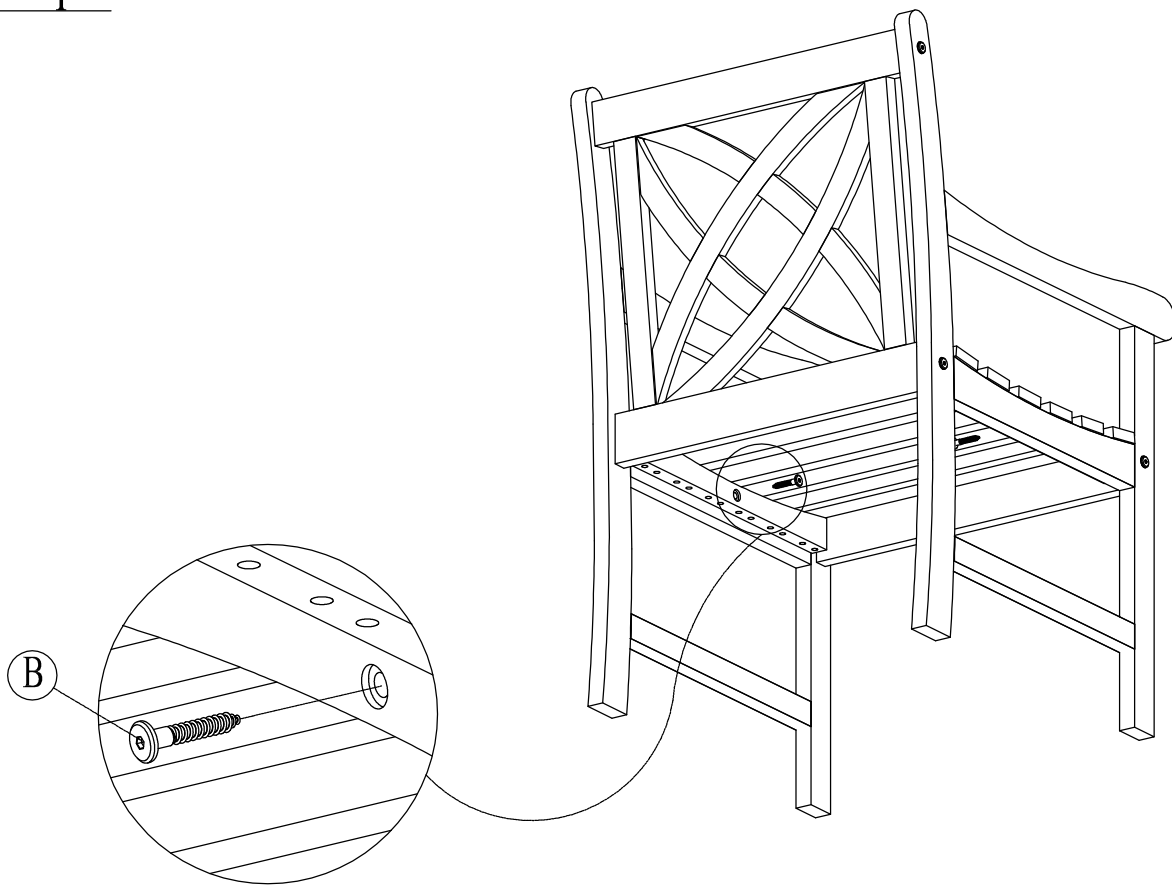

Step 4

