

# Assembly Instructions

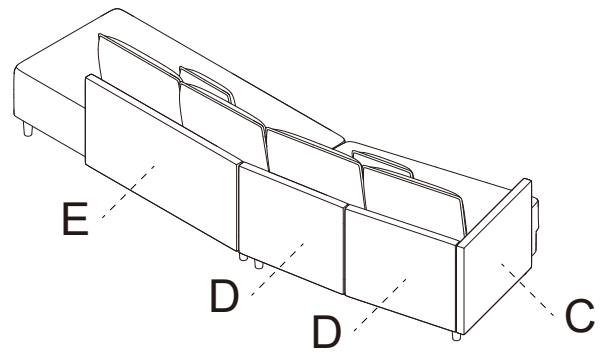

Assemble on the pad to prevent scratching the product.

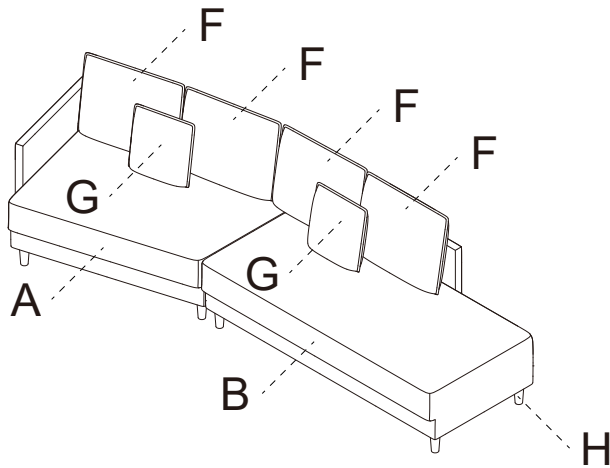

## Parts List

Open the hardware check all parts QTY, thanks

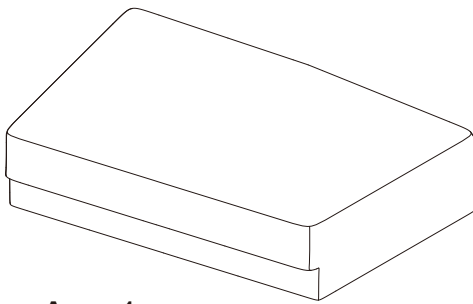

**A x 1**  
( Left seat )

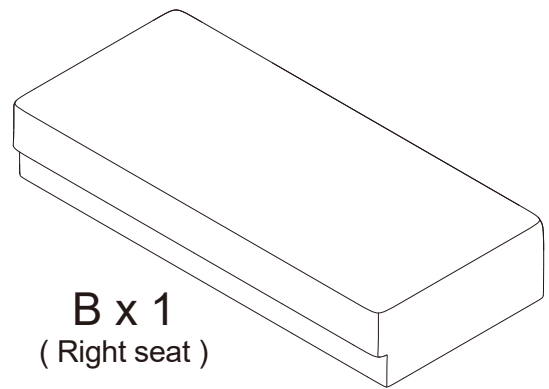

**B x 1**  
( Right seat )

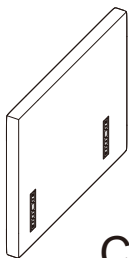

**C x 1**  
( Armrest )  
( Longer than "D" )

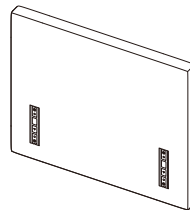

**D x 2**  
( Short back )

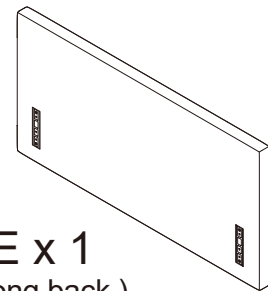

**E x 1**  
( Long back )

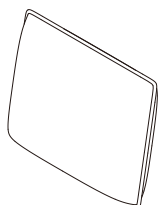

**F x 4**  
( Back cushion )



**G x 2**  
( Pillow )



**H x 8**  
( Wood leg )

**Step 1** Open the velcro on bottom of "A".  
Take out "C", "D", "F", "G", "H".

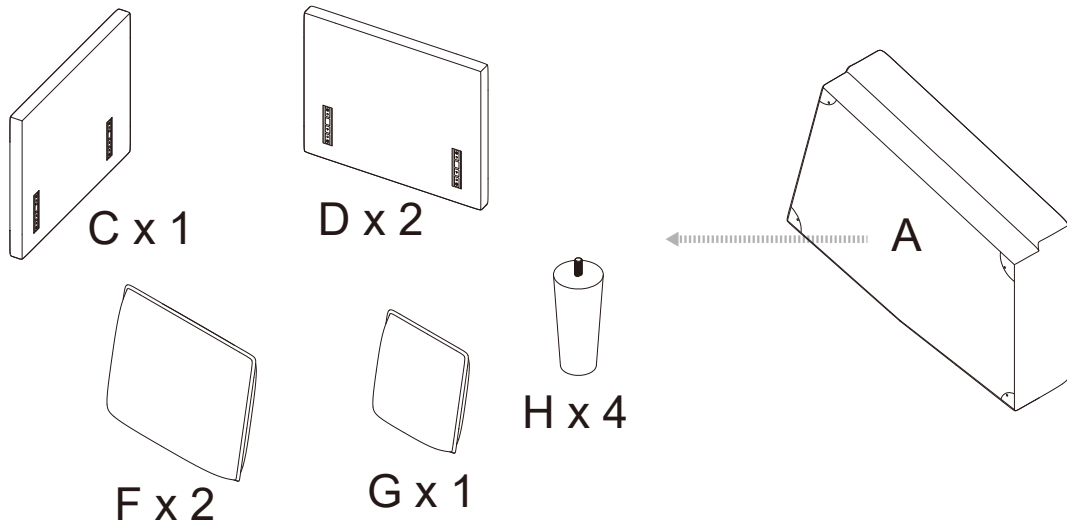

**Step 2** Open the velcro on bottom of "B".  
Take out "E", "F", "G", "H".

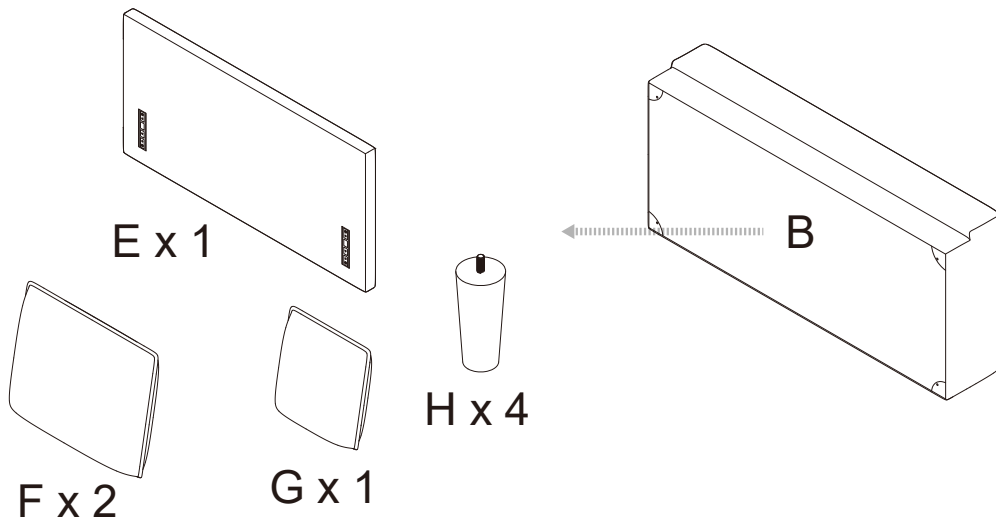

**Step 3** Close the velcro on bottom of "A" and "B".  
Tighten clockwise "H".

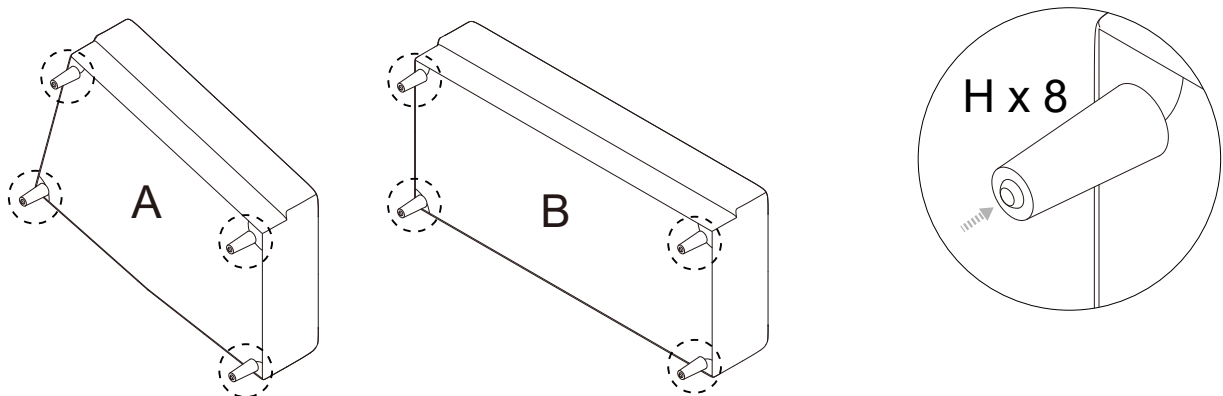

## Step 4

Rotate out saw lock under velcro of "A".  
Push "A" to "B".

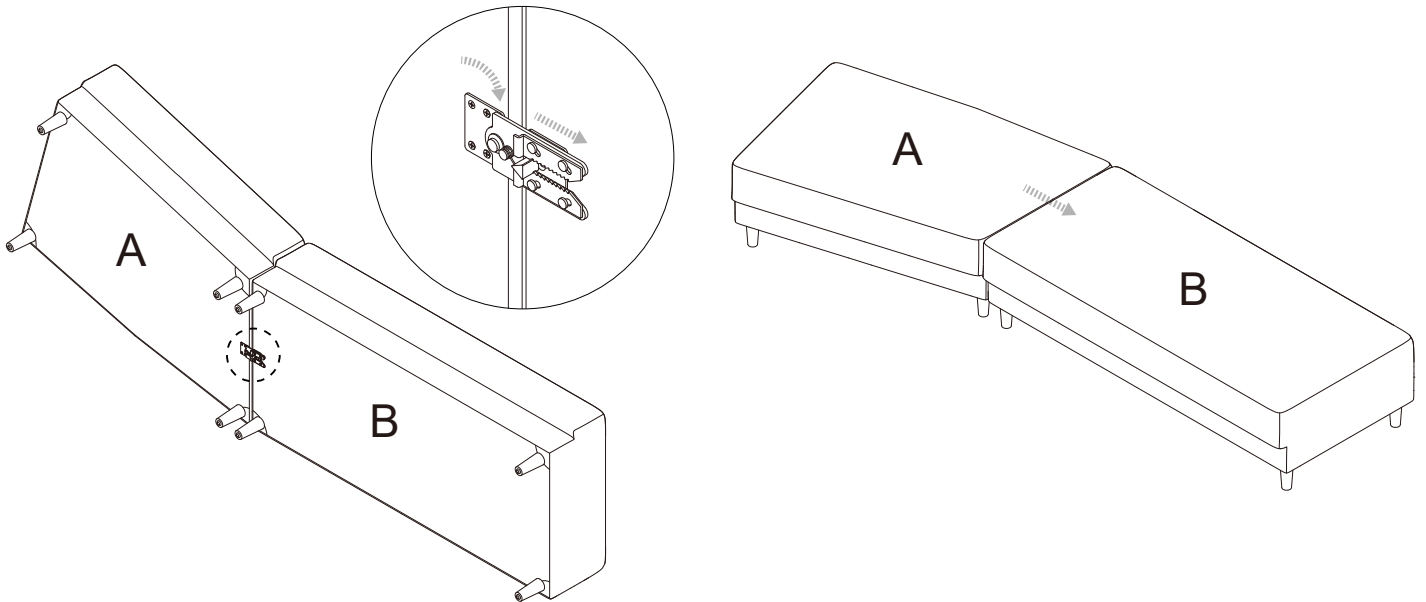

## Step 5

Press "C" and "D" inserting pieces into "A" slots.  
Press "E" inserting pieces into "B" slots.

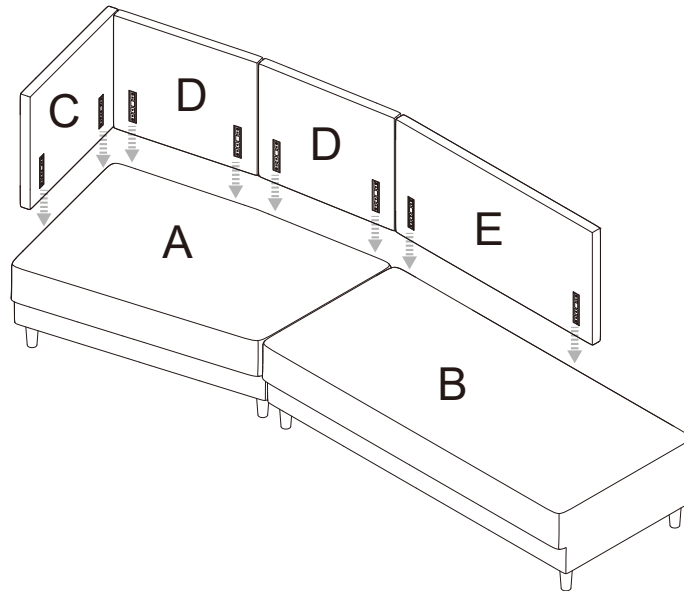

## Step 6

Place the "F".  
Place the "G".

