

User's Manual

—SHOE CABINETS—

The picture is reference, the actual product shall prevail

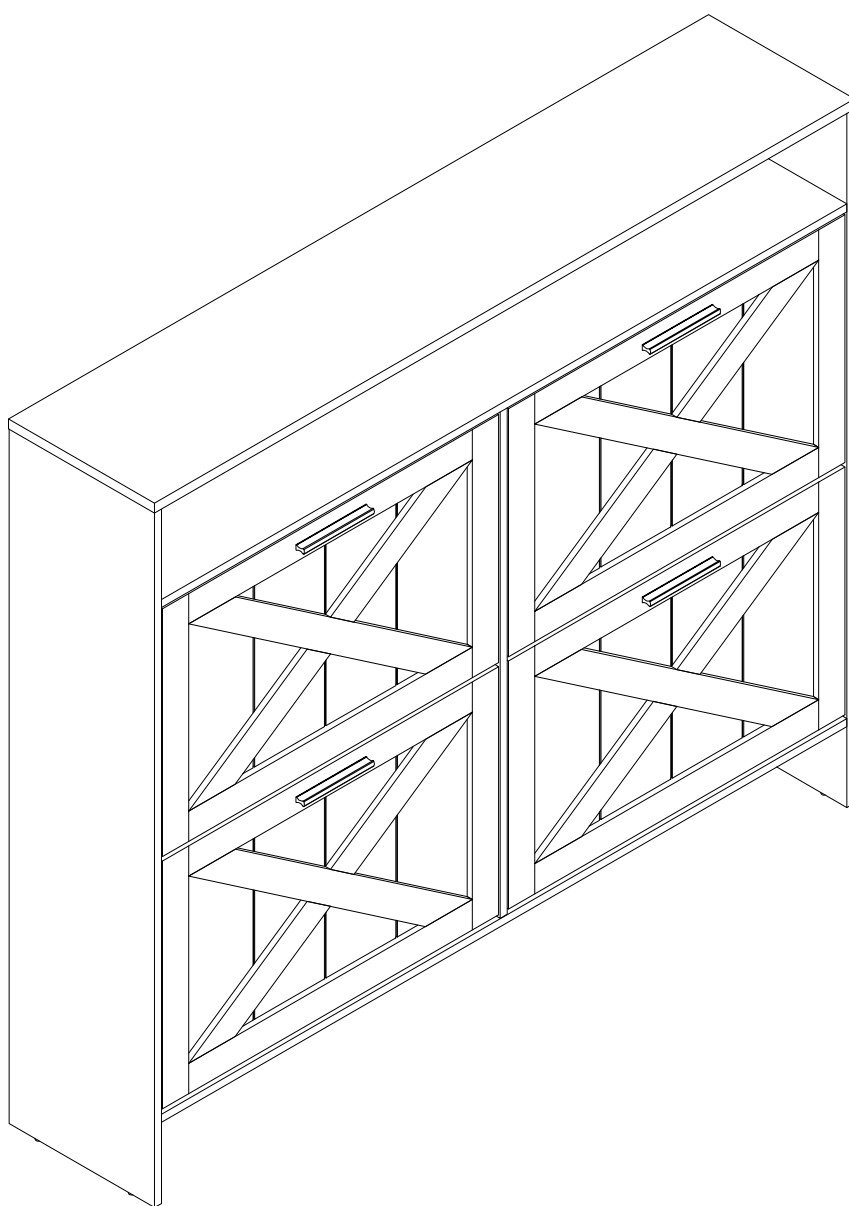

SAFETY WARNING

1.Cleaning:Use a dry cloth to remove any dust or debris from the rack.If needed, adamp cloth can be used, but ensure the rack is dried thoroughly afterward.

2.Stay Dry: Although made of iron, the rack can still rust if exposed to moisture for extended periods. Do not allow water to pool around or on the rack.

3.Inspecting Components: Periodically inspect the rack for any signs of wear,loose screws, or damaged parts Replace or repair any compromised elements to ensure stability and safety.

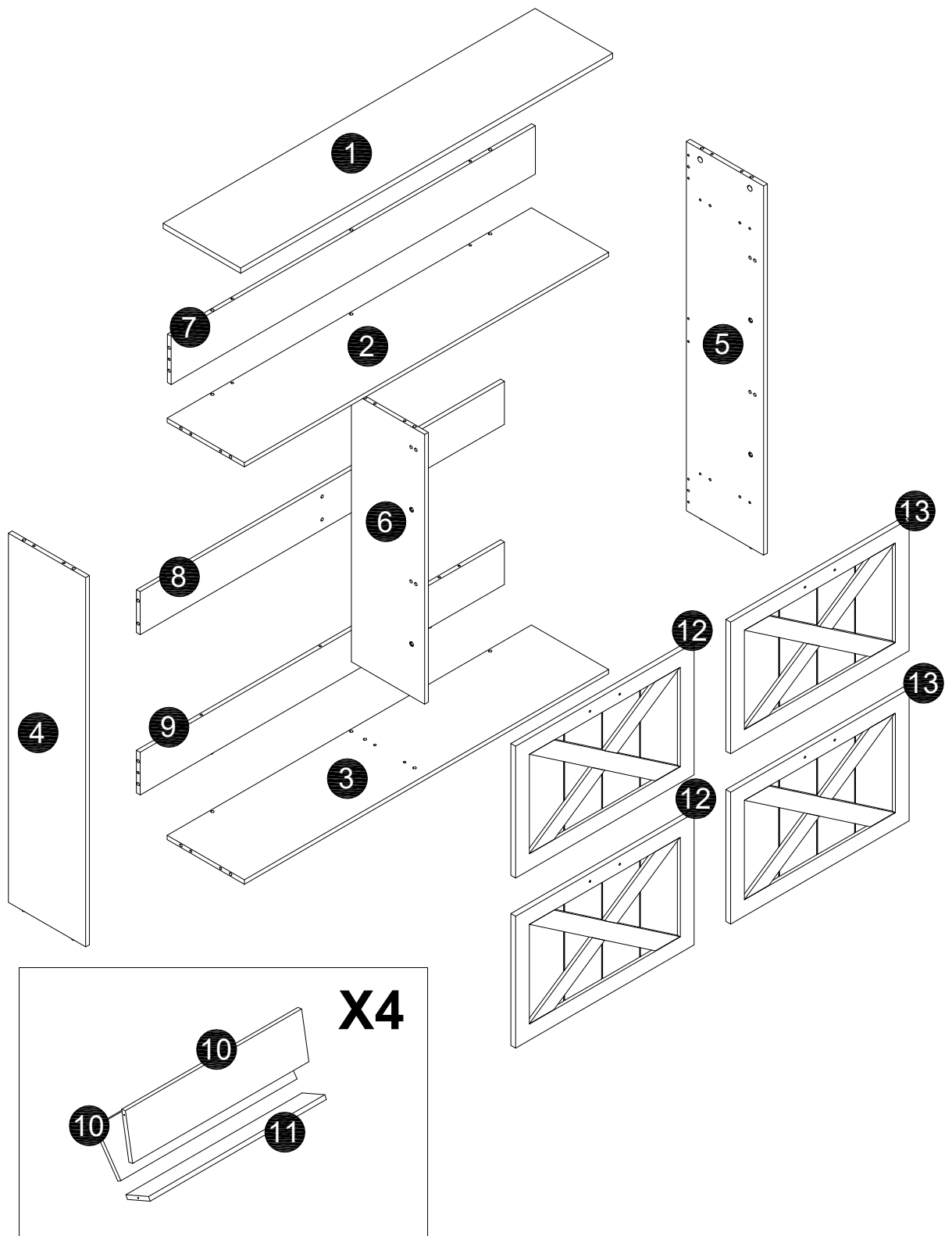







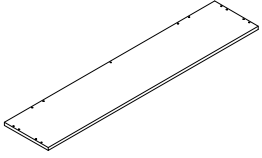
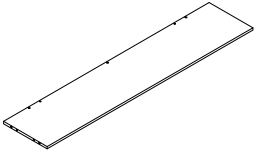
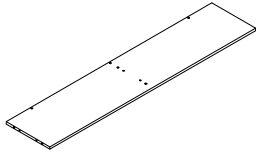
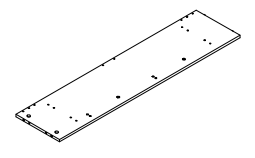
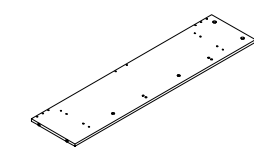
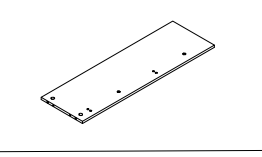
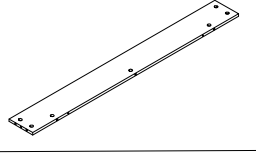
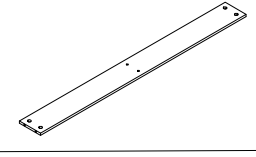
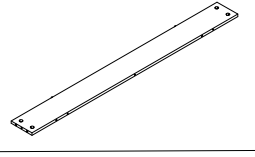
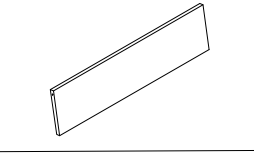
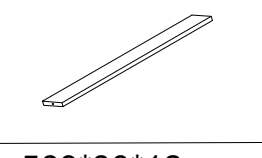
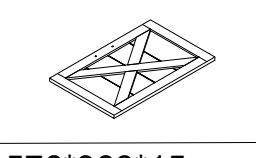
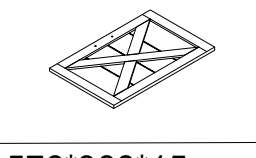





! WARNING:

1. Before beginning assembly, please ensure that you have all the required parts if anything is missing, please contact us for assistance instead of immediately initiating a return. We are here to help.
2. Please read each step carefully before starting the installation.
3. Please complete one step before proceeding to the next step to avoid difficulties.
4. Please put on gloves to avoid chafing.

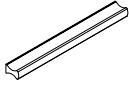

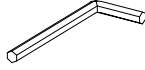
HARDWARE LIST

1	1PC		1200*250*15mm
2	1PC		1175*248*12mm
3	1PC		1175*248*12mm
4	1PC		1031*249*12mm
5	1PC		1031*249*12mm
6	1PC		752*235*12mm
7	1PC		1175*135*12mm
8	1PC		1175*120*12mm
9	1PC		1175*120*12mm
10	8PCS		569*138*12mm
11	4PCS		569*80*12mm
12	2PCS		576*368*15mm
13	2PCS		576*368*15mm

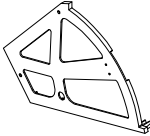
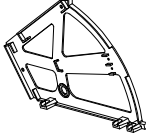
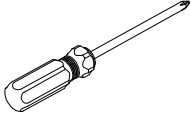
HARDWARE LIST

A	29PCS		$\text{Ø}6 \times 35 \text{mm}$
B	29PCS		$\text{Ø}15 \times 10 \text{mm}$
C	26PCS		$\text{Ø}6 \times 30 \text{mm}$
D	10PCS		$\text{Ø}6 \times 38 \text{mm}$
E	48PCS		$\text{Ø}3.5 \times 14 \text{mm}$
F	8PCS		$\text{Ø}4 \times 18 \text{mm}$
G	4PCS		$103 \times 15 \times 7 \text{mm}$
H	8PCS		$26 \times 16 \times 9 \text{mm}$
I	1PC		M4
J	8PCS		M6*18mm
K	8PCS		$\text{Ø}19 \times 1 \text{mm}$
L	8PCS		$\text{Ø}14 \times 9 \text{mm}$
M	4PCS		/
N	4PCS		/
O	1PC		/

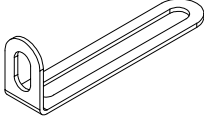
ANTI-OVERTURN HARDWARE BAG

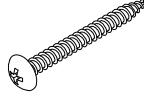
P	2PCS		$\text{Ø}3.5 \times 12 \text{mm}$
Q	2PCS		/
R	2PCS		/
S	2PCS		$\text{Ø}4 \times 40 \text{mm}$

STEP1

Cx2



Ø6x30mm

Dx3

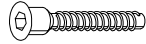

Ø6x38mm

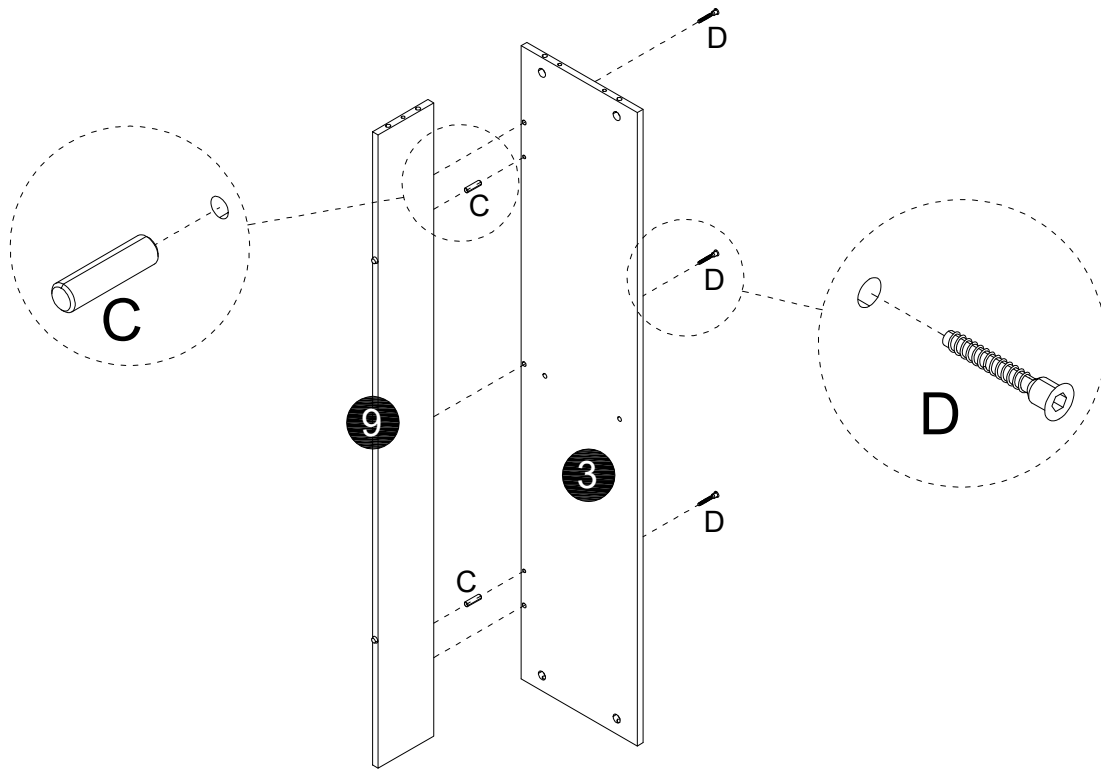
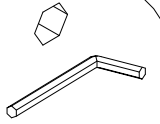

STEP2

Ax2

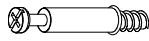

Ø6x35mm

Px2



Ø3.5x12mm

Qx2

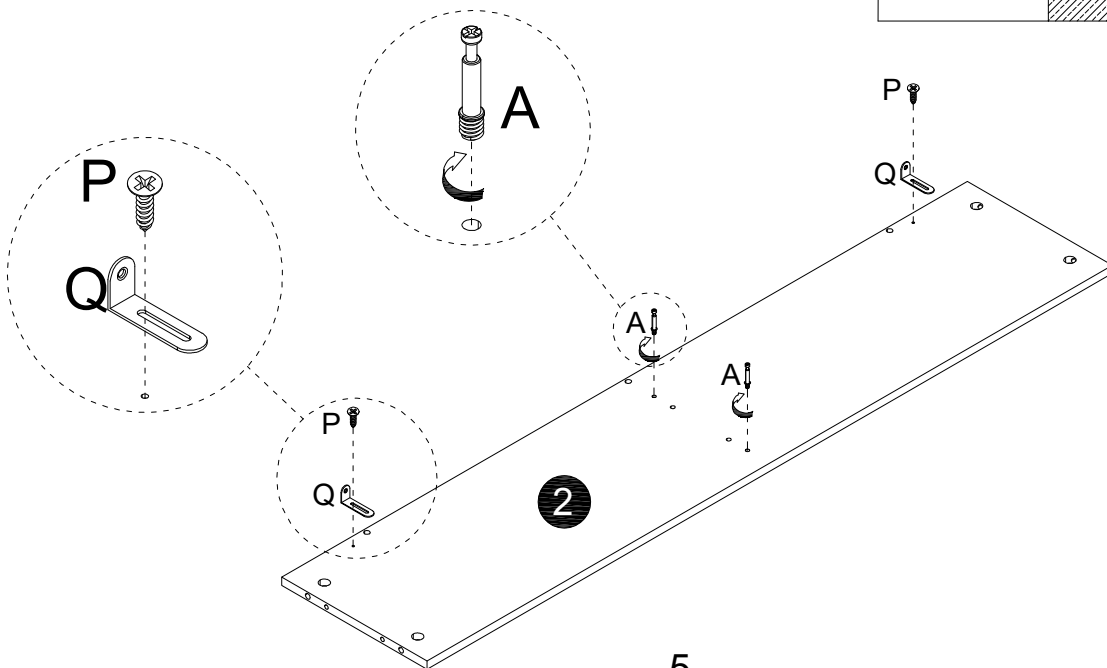
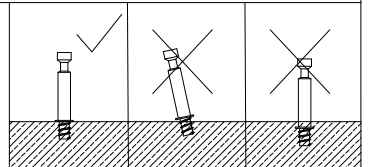
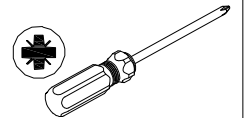
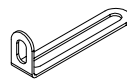

STEP3

Cx2



Ø6x30mm

Dx3

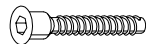

Ø6x38mm

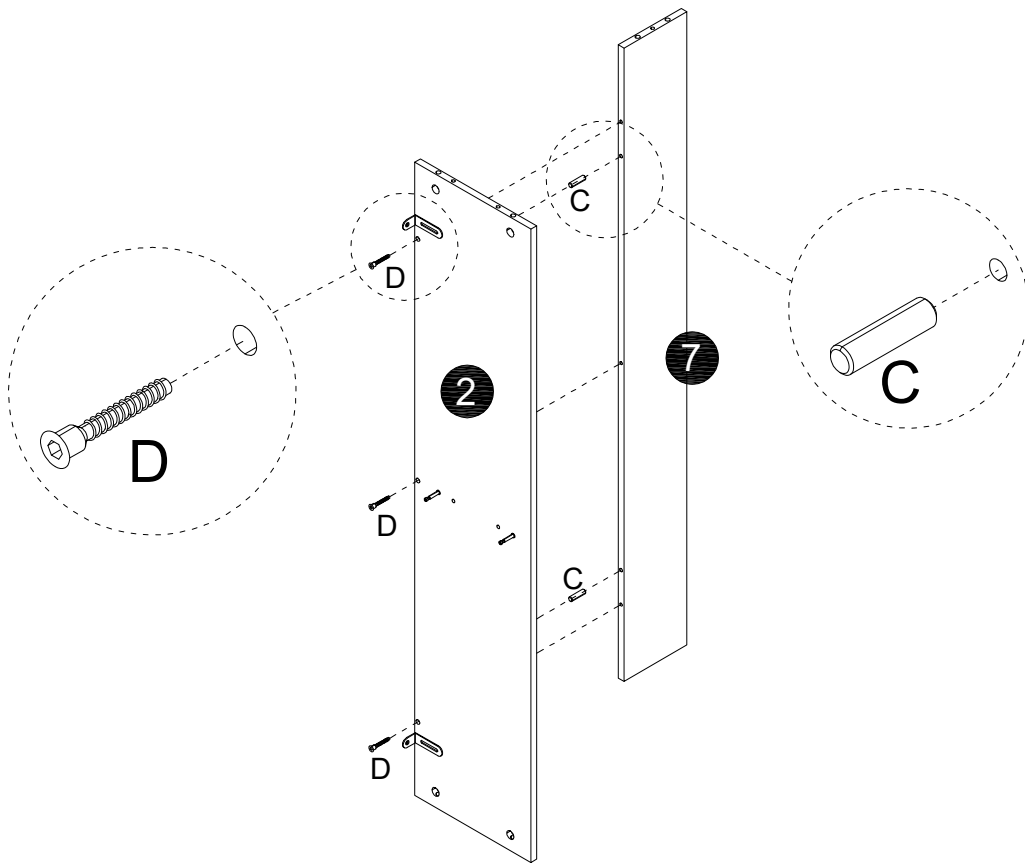
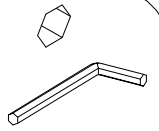

STEP4

Hx4



26*16*9mm

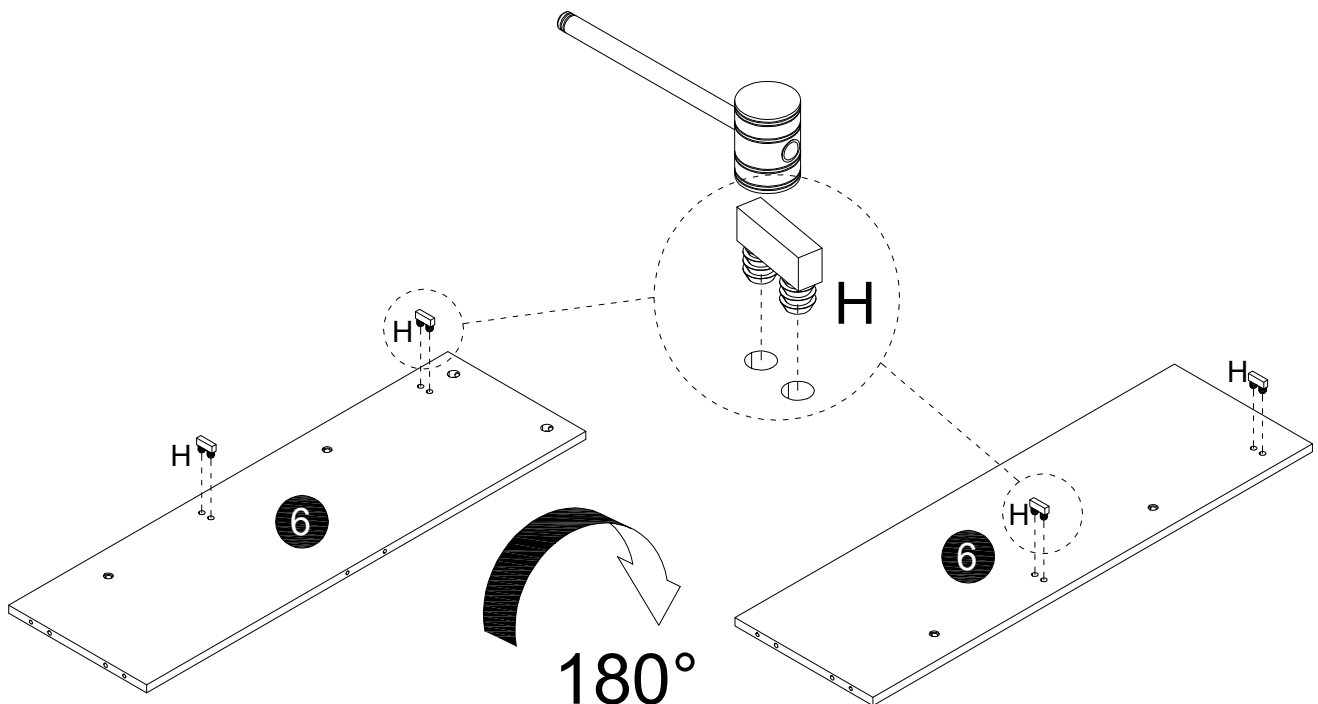

STEP5

Bx2



Ø15x10mm

Cx4



Ø6x30mm

Dx2

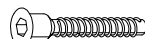

Ø6x38mm

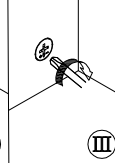
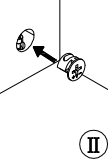
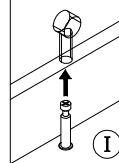
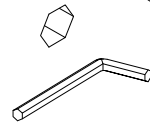
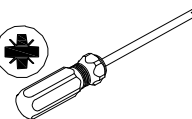

Please pay attention to the direction of board 6

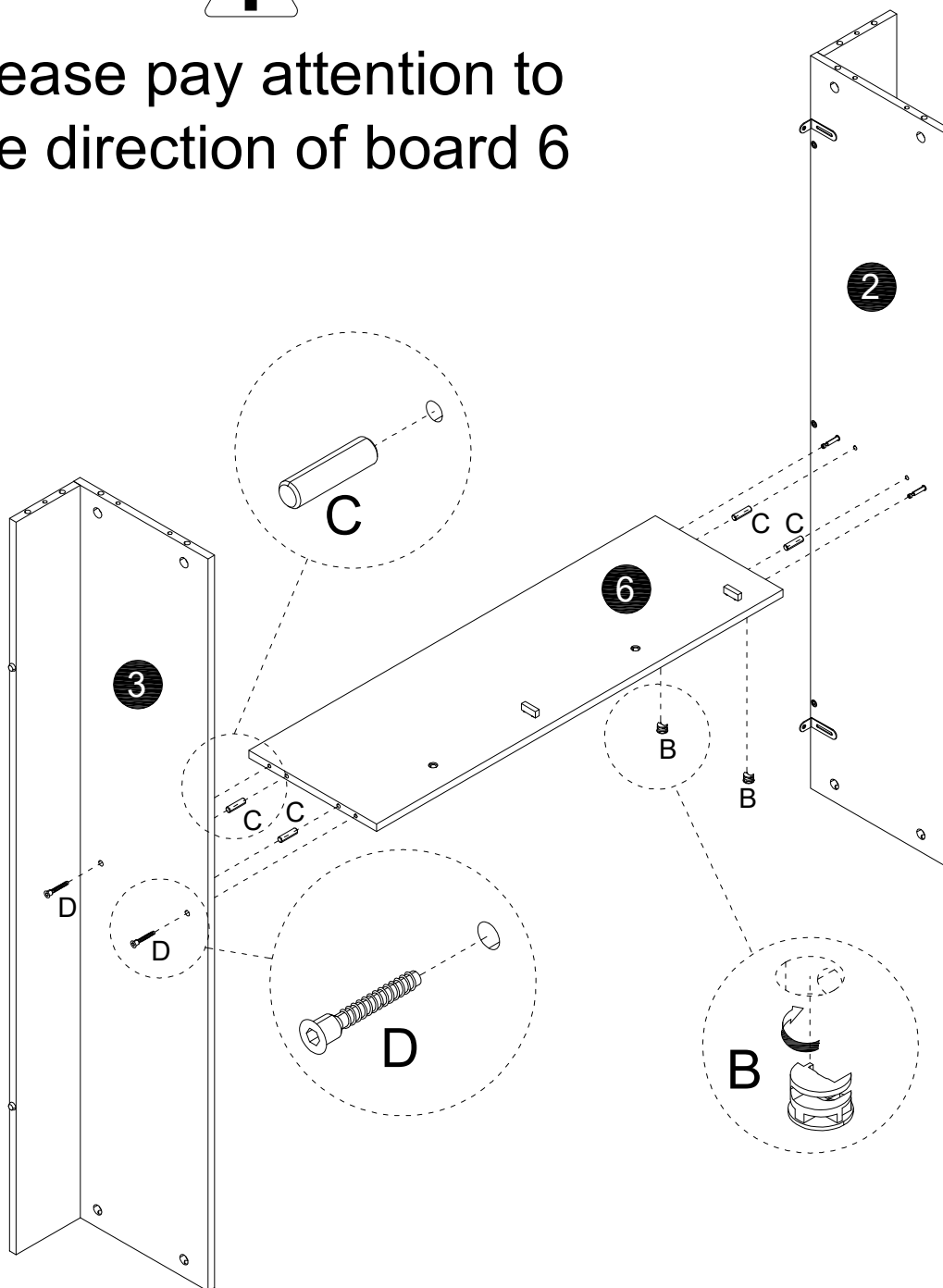

STEP 6

Ax10

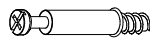

Ø6x35mm

Hx2



26*16*9mm

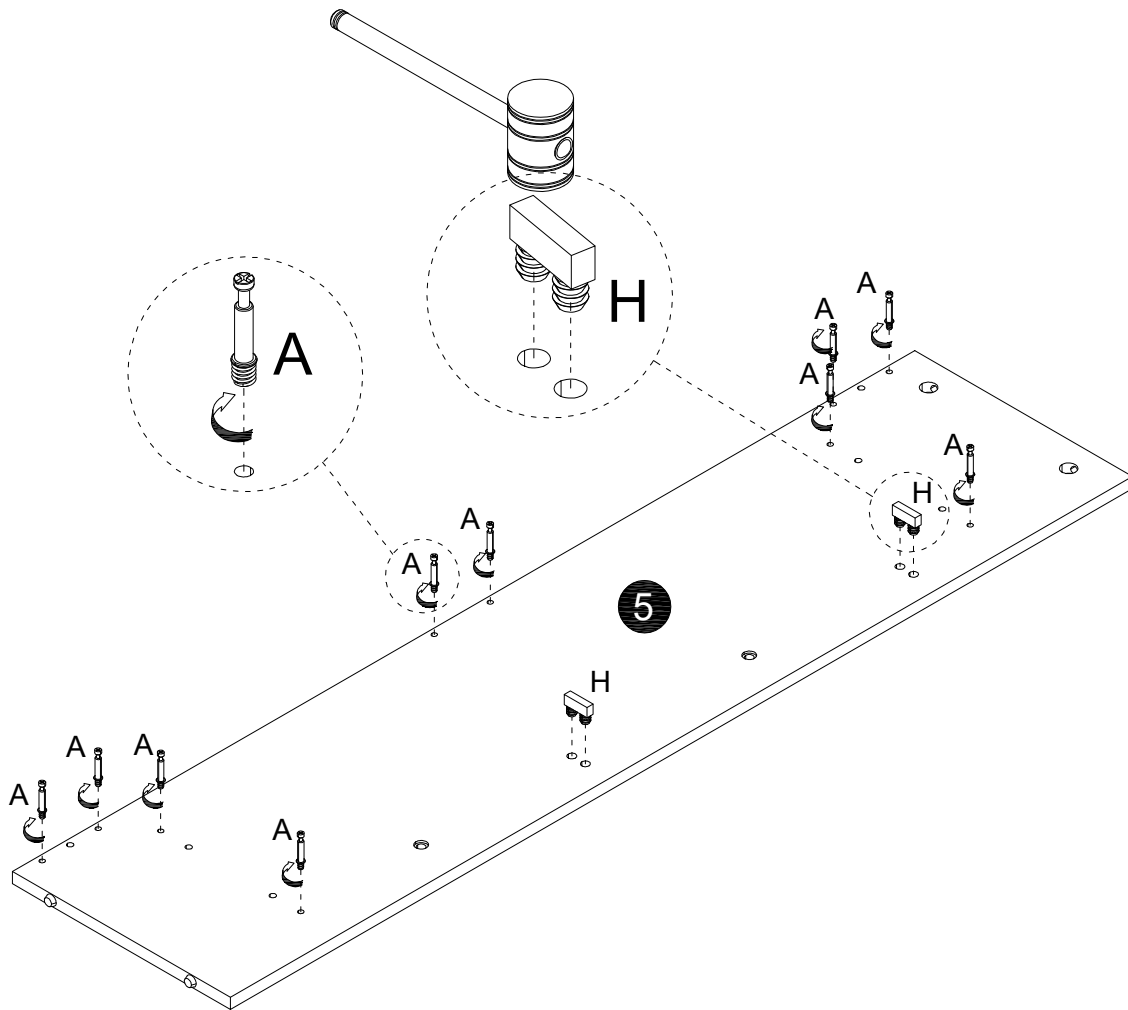
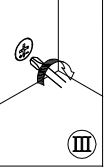
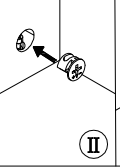
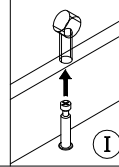
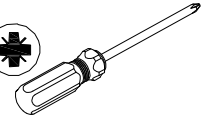

STEP 7

Bx8



Ø15x10mm

Cx6



Ø6x30mm

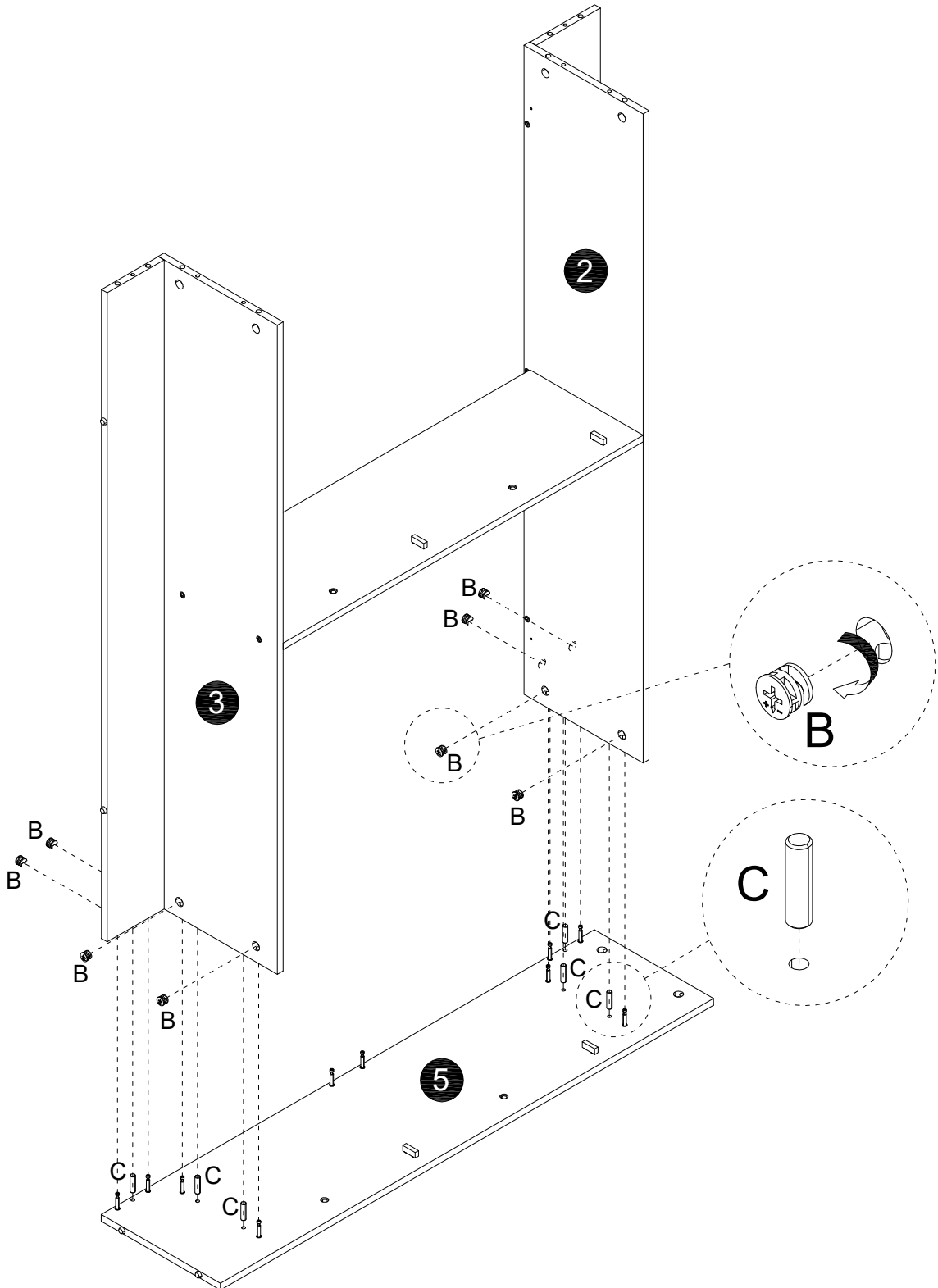
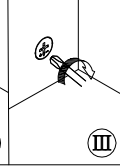
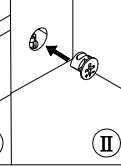
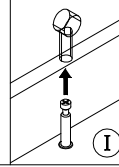
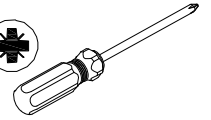

STEP 8

Bx2



Ø15x10mm

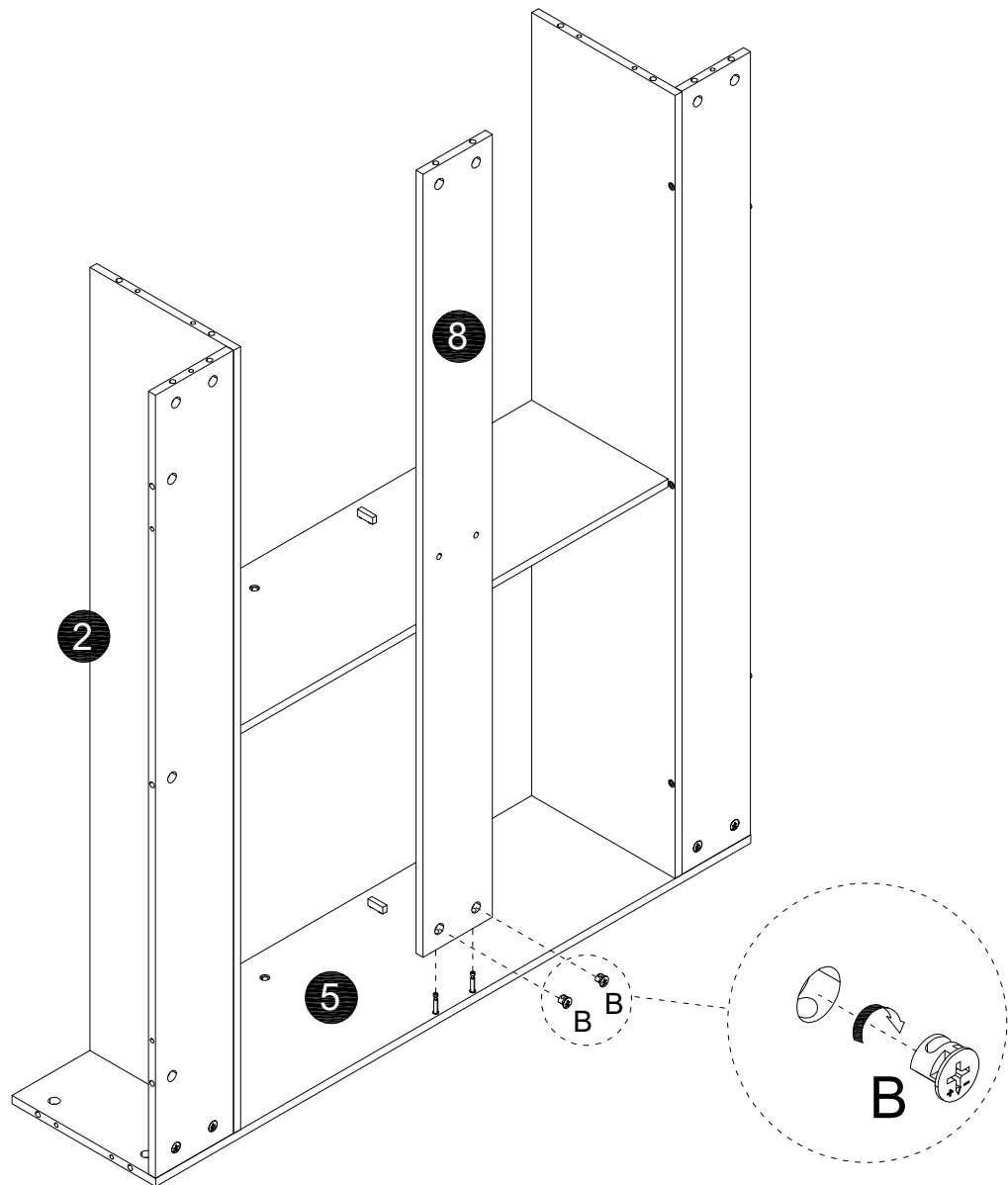
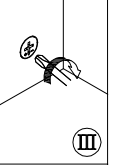
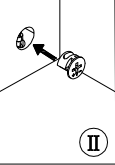
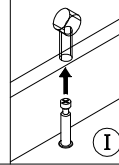
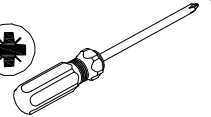

STEP9

Dx2



Ø6x38mm

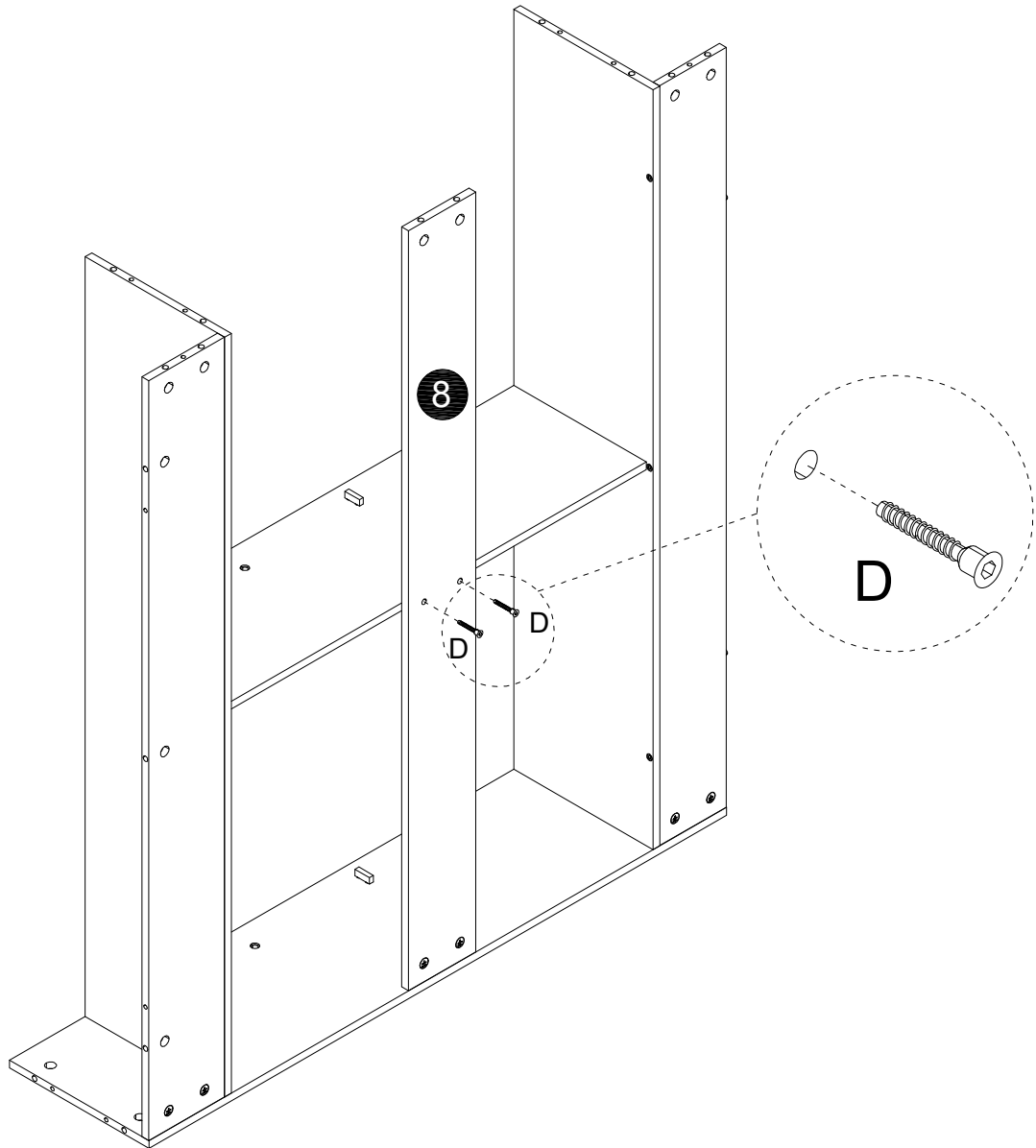
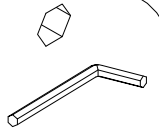

STEP11

Bx10



Ø15x10mm

Cx6



Ø6x30mm

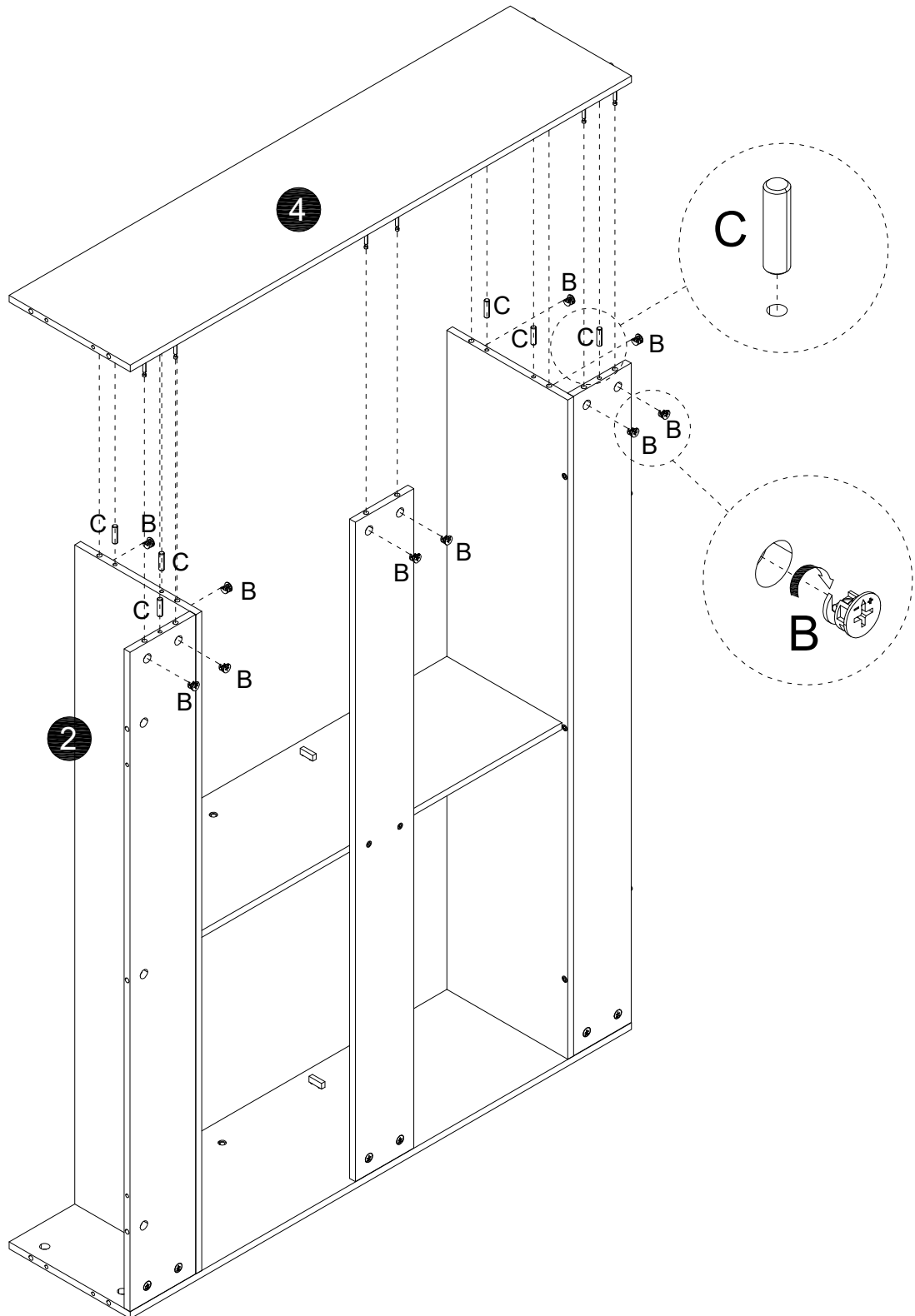
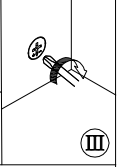
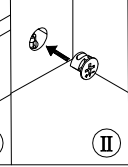
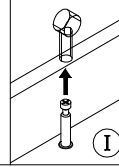
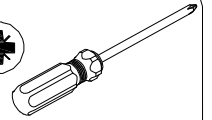

STEP12

Ax7

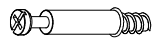

Ø6x35mm

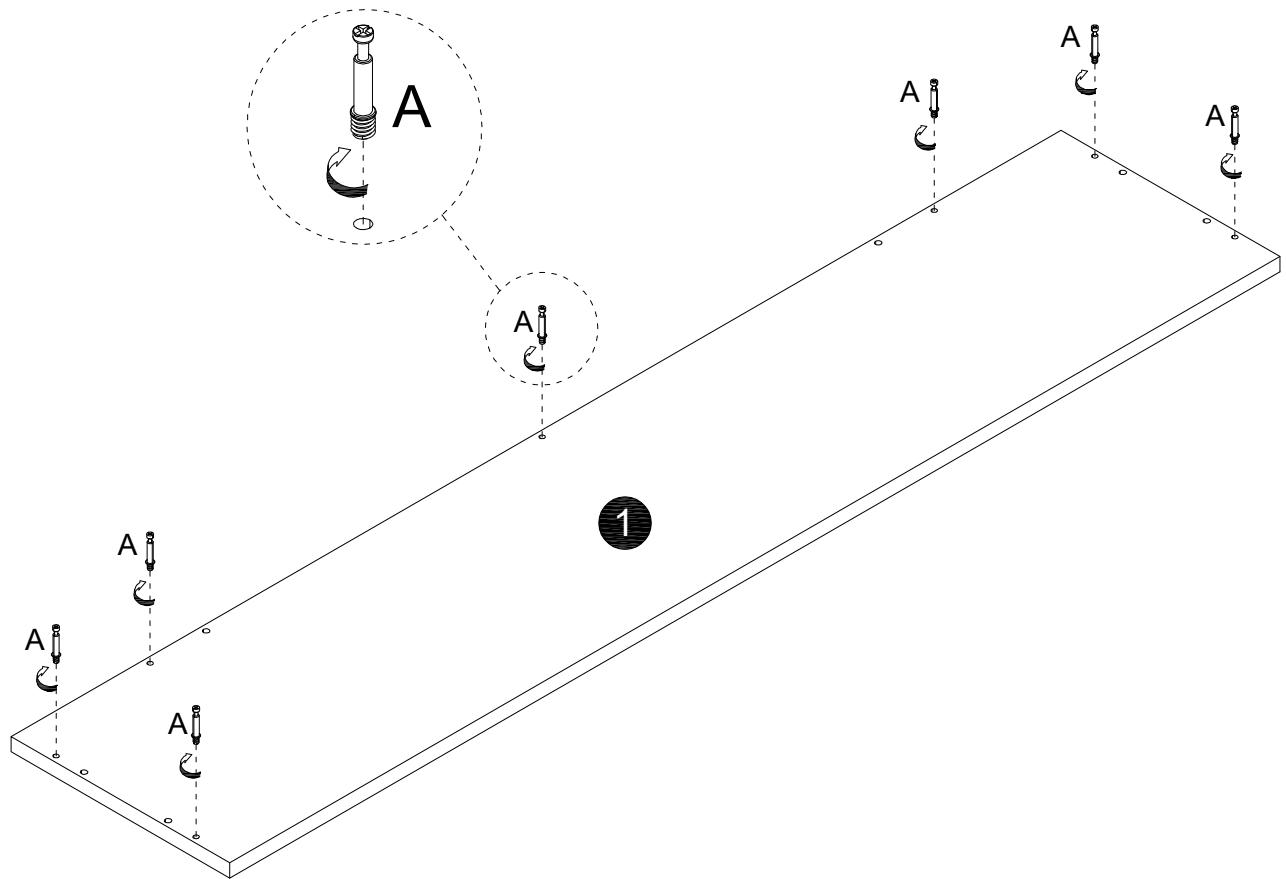
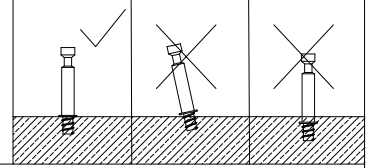
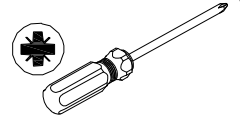

STEP13

Bx7



Ø15x10mm

Cx6



Ø6x30mm

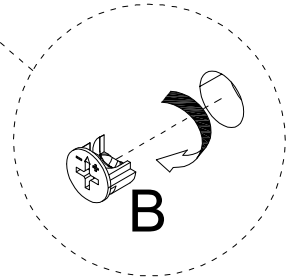
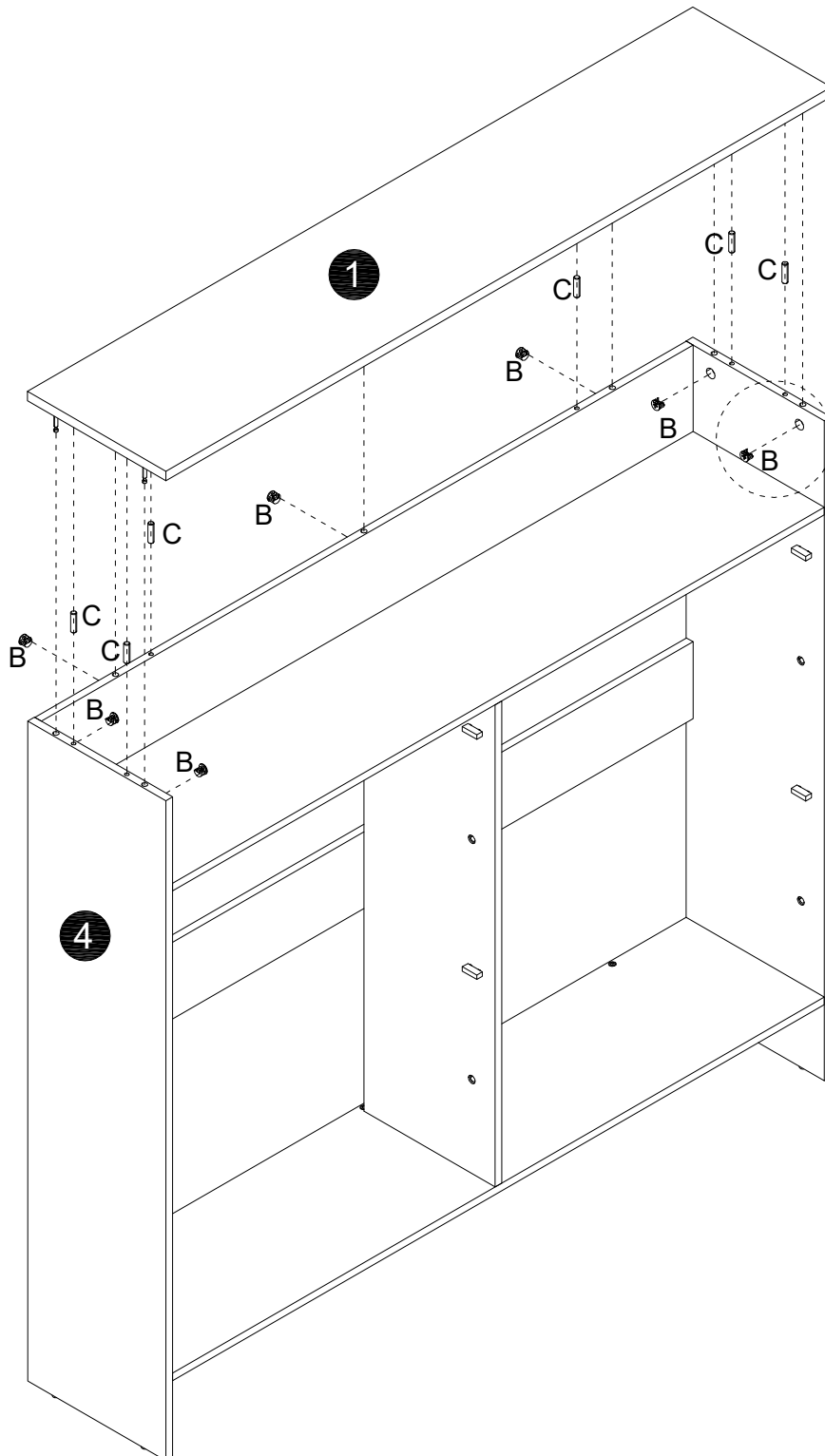
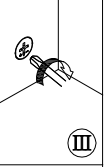
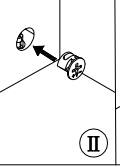
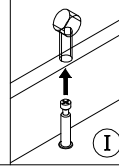
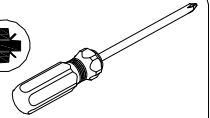

STEP14

Rx2



Sx2

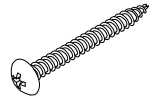

Ø4x40mm

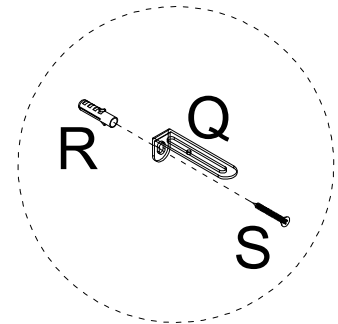
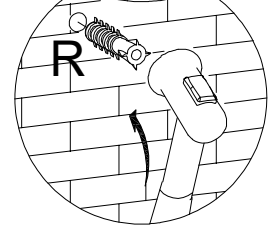
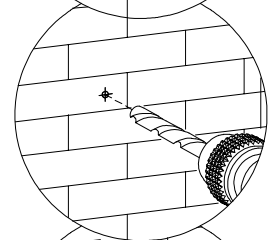
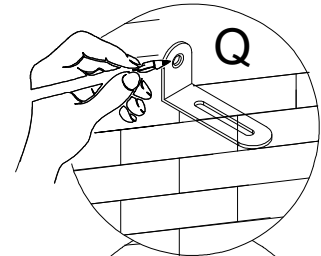
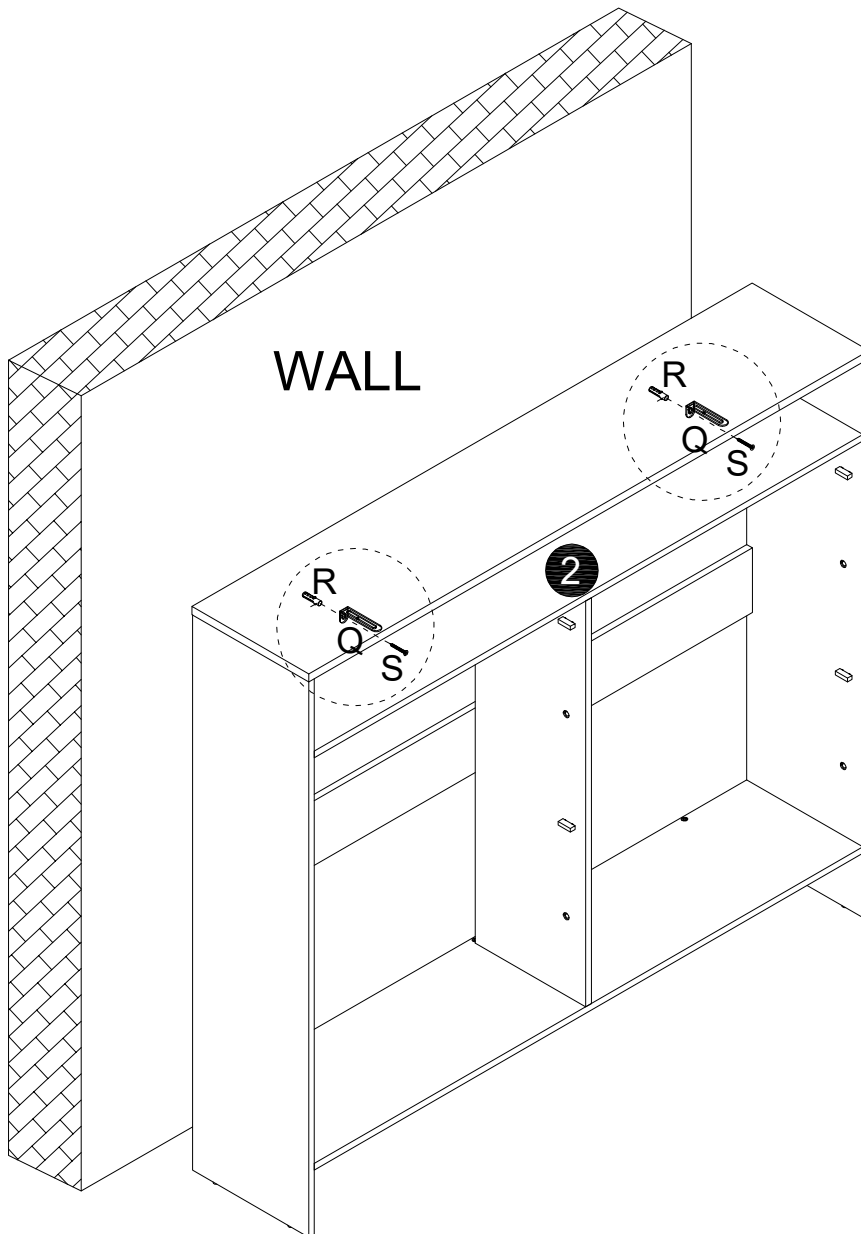
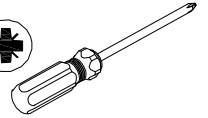

STEP15

Ex16



Ø3.5x14mm

Mx4

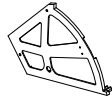

Nx4

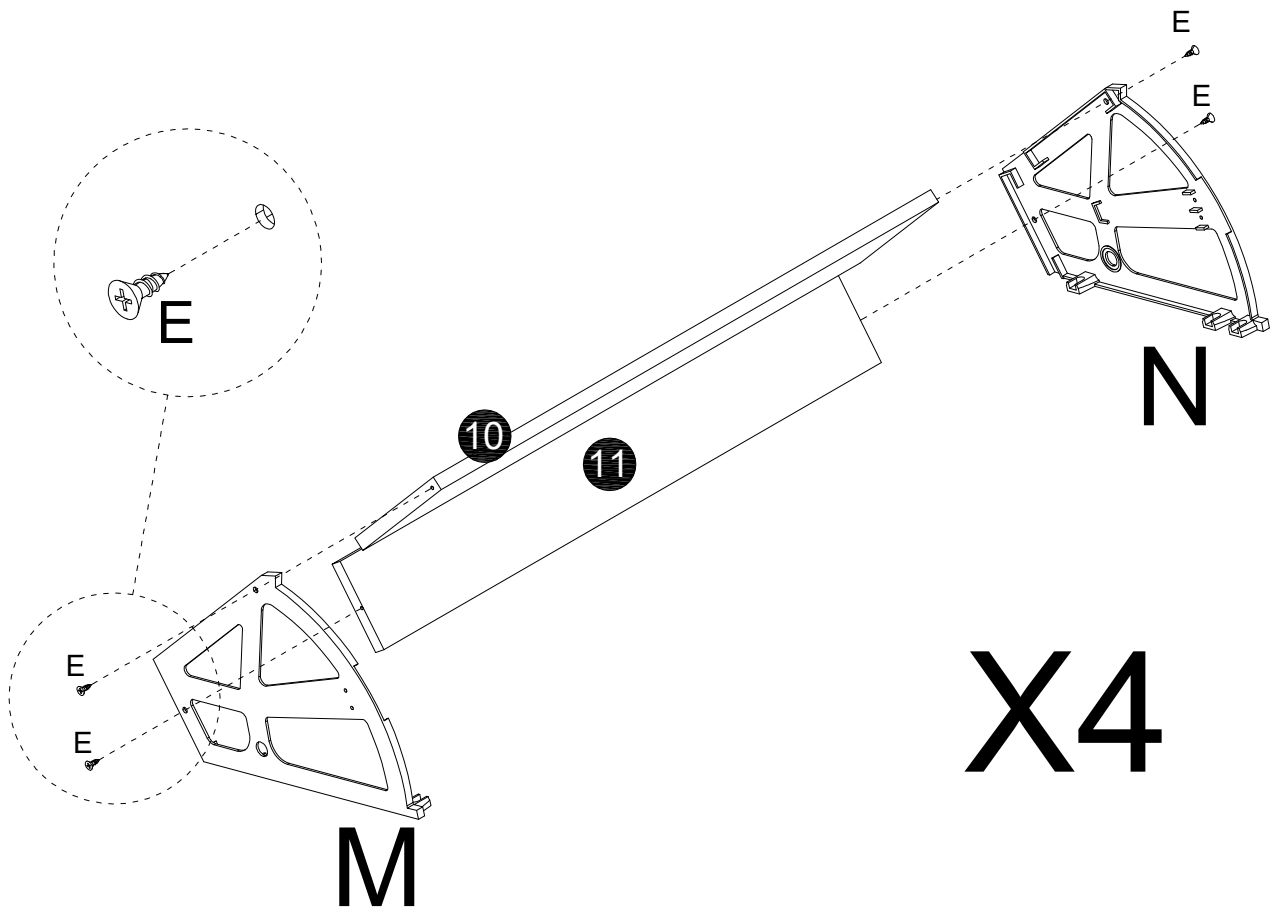
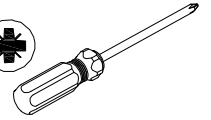
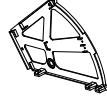

STEP16

Ex12



Ø3.5x14mm

Fx4



Ø4x18mm

Gx2

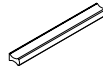

103*15*7mm

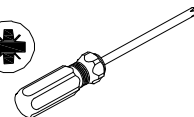

X2

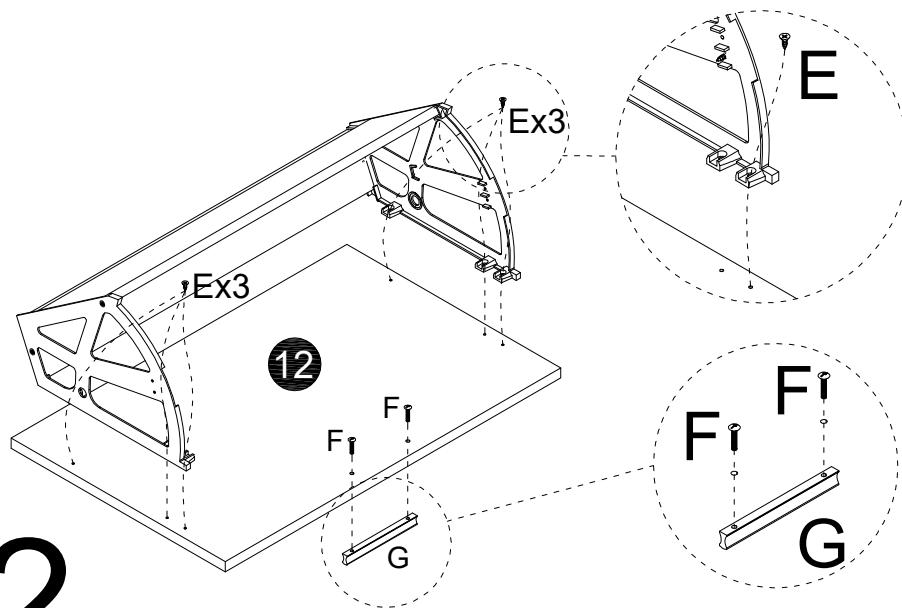

STEP17

Ex12



Ø3.5x14mm

Fx4



Ø4x18mm

Gx2



103*15*7mm

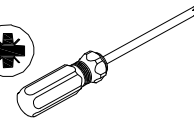

X2

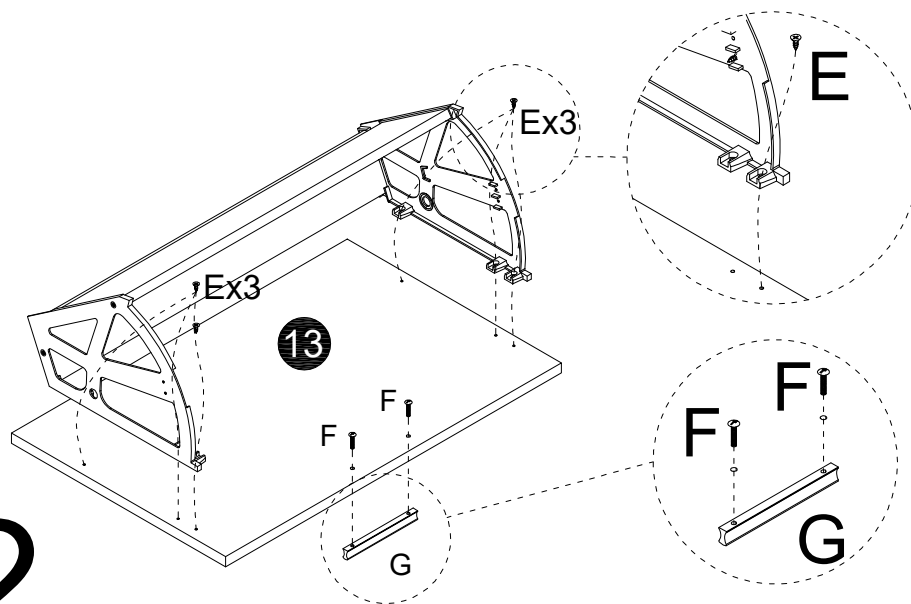

STEP18

Jx8



M6*18mm

Kx8



Ø19x1mm

Lx8



Ø14x9mm

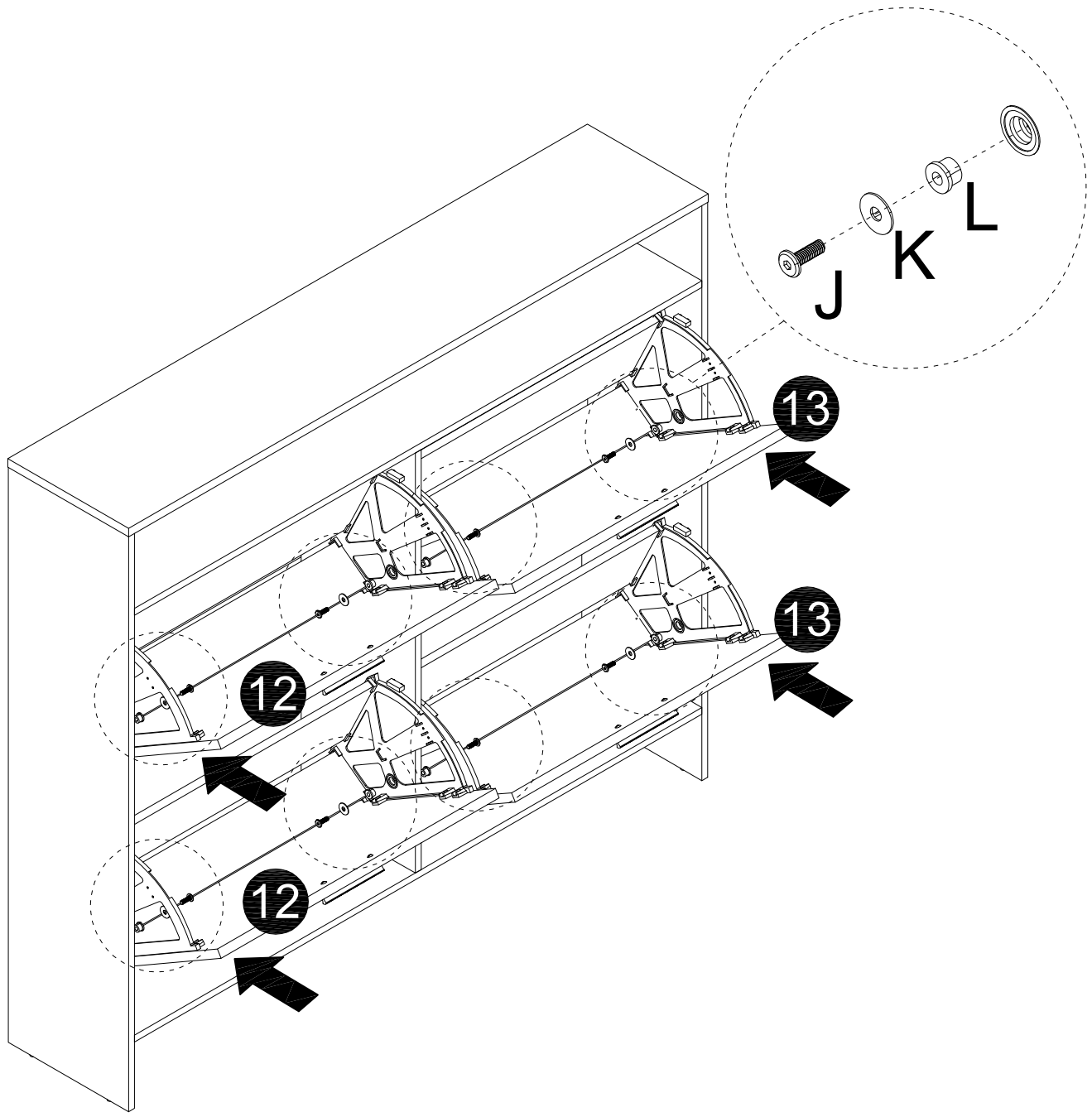
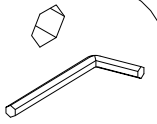

STEP19

Ex4



Ø3.5x14mm

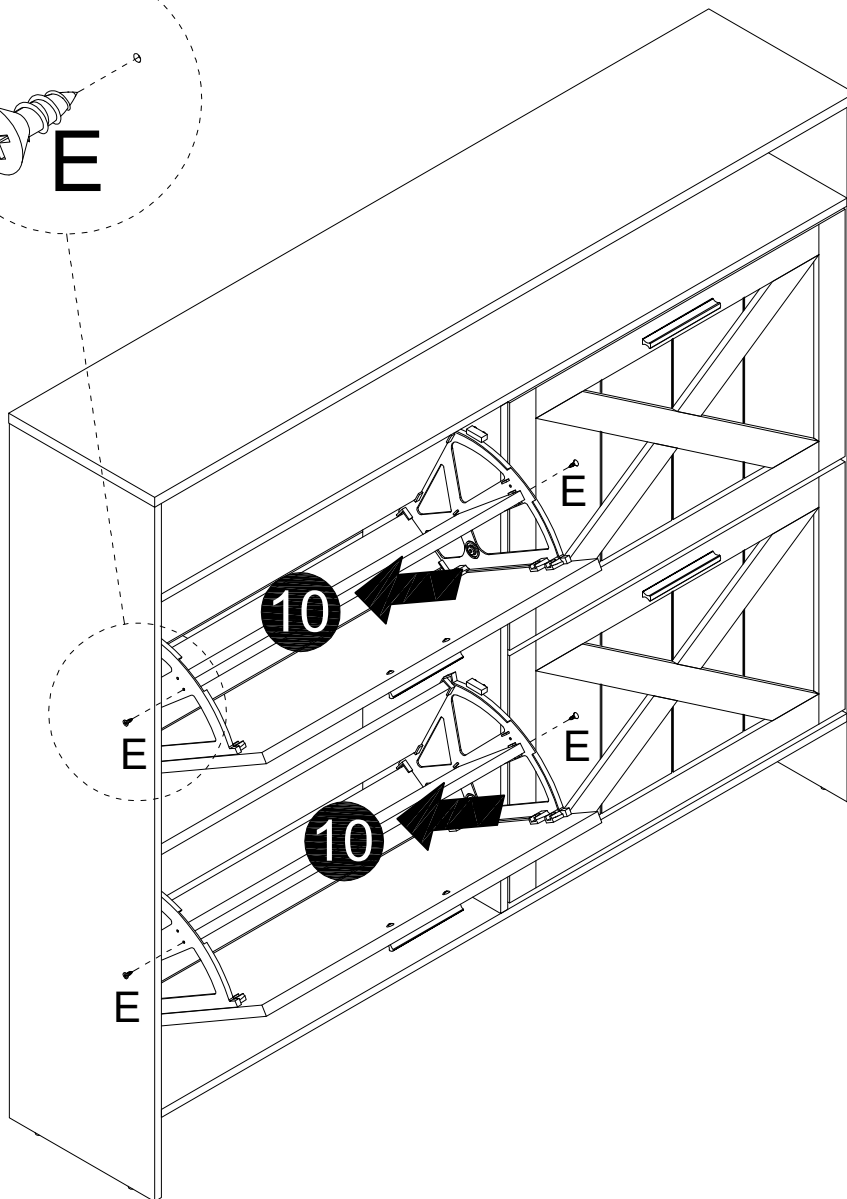
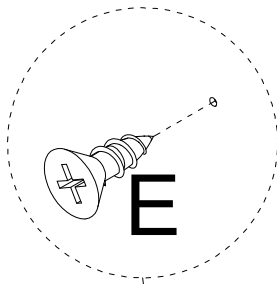
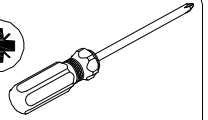

STEP20

Ex4



Ø3.5x14mm

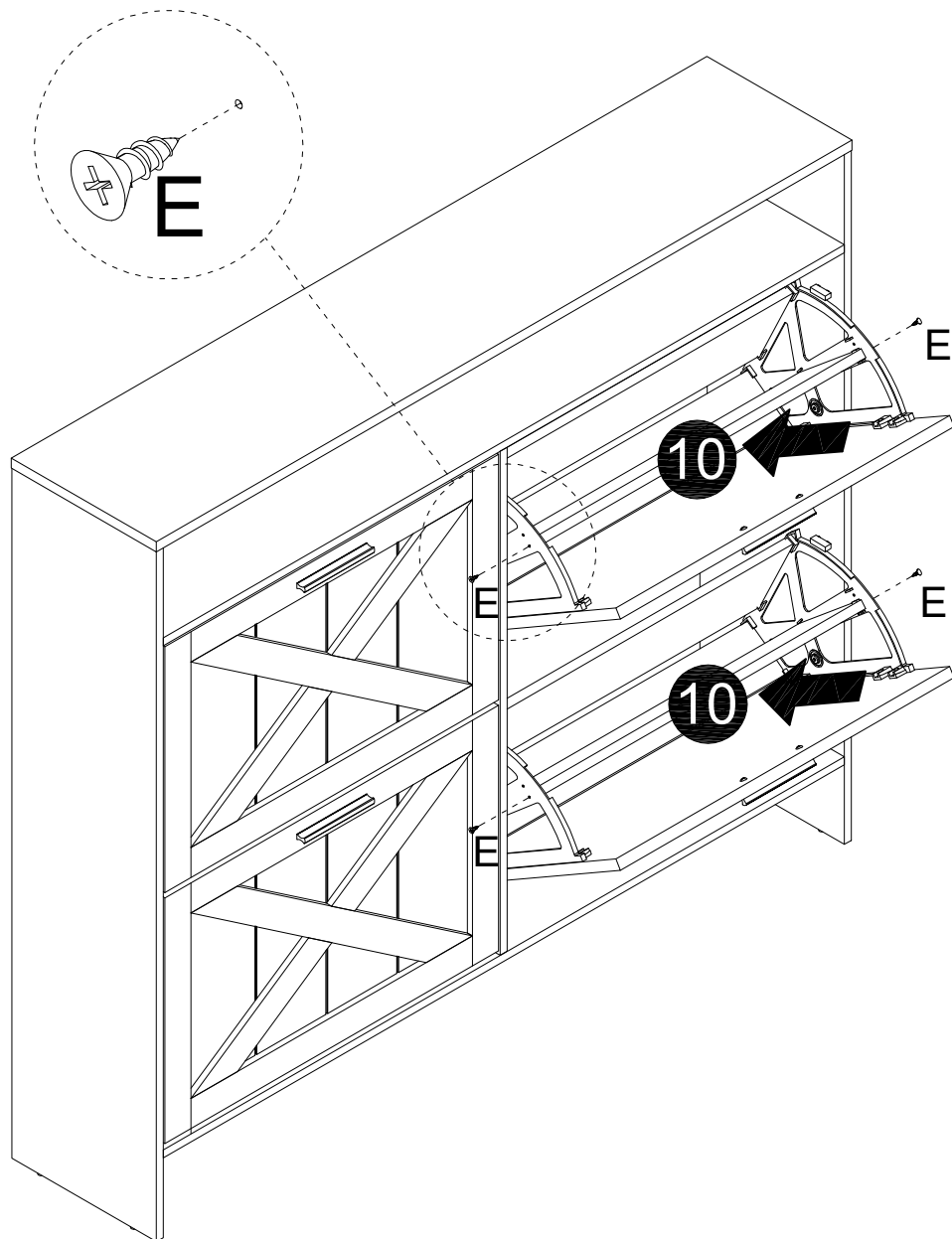
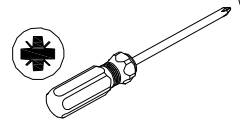

STEP21

Installation Completed

