

ASSEMBLY INSTRUCTIONS

Tucker Desk

ASSEMBLY
REQUIREMENTS

2-Person
Assembly

1.5 Hours
Assembly Time
(Approximate)

Tools Required
(Not Provided)



Phillips Screwdriver



Flat Screwdriver

Thank you for purchasing our product!

Please refer and use this assembly instruction to assemble the product.
Contact our customer service department in case there are any missing or damage parts or hardware.
Replacement parts are normally shipped within 2 or 3 days.

ASSEMBLY PREPARATION

1. Remove all packaging materials, staples and packing straps from the carton.
2. Refer to Parts List and Hardware List, and ensure parts and hardware are correct before assembly. Contact customer service for missing parts.
3. Place all wooden parts on a clean, flat and soft surface (e.g. carpet or rug) to prevent scratch and damage to parts.

SAFETY PRECAUTION

1. KEEP ALL HARDWARE PARTS OUT OF REACH OF CHILDREN.
2. DISPOSE PLASTIC PACKAGING MATERIAL IMMEDIATELY TO AVOID ANY RISK OF SUFFOCATION TO CHILDREN AND ANIMALS.

TIPS FOR ASSEMBLY





1. Allow ample room for assembly and in close proximity to where product will be placed.
2. Assemble the product on a surface that does not scratch or damage the exterior gloss and finish of the furniture.
3. Identify all of the parts, hardware and quantities required for each step.
4. During assembly, do not over-tighten any fittings as this may cause damage.
5. DO NOT USE POWER TOOLS TO ASSEMBLE THIS PRODUCT.
6. Always place the product on a flat, level surface.
7. Do not sit or stand on the partially assembled product; only use the product for which it is intended.

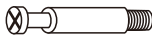

CARE AND MAINTENANCE

- Use a slightly damp cloth to clean the product. Do not use bleach or abrasive cleaning material.
- Check all the fittings periodically and re-tighten as necessary. Do not use the product if any of the parts is damaged or broken.
- Never allow any kind of liquid to remain on your furniture. Absorption can cause wood to warp or delaminate.
- Do not place hot items (e.g. hot drinks) directly onto the wood surface.
- Do not drag and/or pull the furniture.







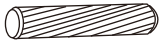

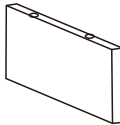
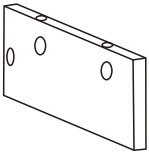
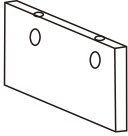
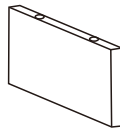
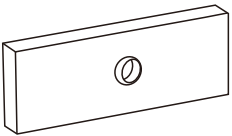
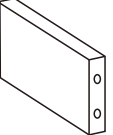
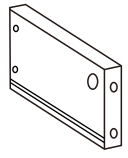

This product is for indoor and household use only - not for commercial use.

HARDWARE LIST

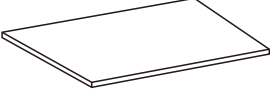
Item	Description	Part	Qty
A1	Cam-bolt		22
A2	Cam-lock		22
B1	Screw M6X50mm		4
B2	Screw M6X30mm		8
B3	Wood Screw M6X12mm		3

Item	Description	Part	Qty
C	Screw ST3.5X30mm		6
D	Screw ST5.0X40mm		8
E	Leg Stud(threaded)		4
F	Wood Dowel 8X30mm		8

PARTS LIST

① Top Panel  x1	② Shelf Top Panel  x1	③ Shelf Rear Panel  x1	④ Shelf Left Panel  x1
⑤ Shelf Right Panel  x1	⑥ Inner Shelf Panel  x1	⑦ Inner Shelf Panel  x1	⑧ Drawer Front Panel  x2
⑨ Drawer Left Panel  x2	⑩ Drawer Right Panel  x2	⑪ Drawer Rear Panel  x2	⑫ Drawer Bottom Panel  x2
P1 Leg Frame  x2	P2 Rear Table Support  x1 P3 Front Table Support  x1	P4 Leg Stretcher  x1	P5 Vertical Stretcher  x2

INSTRUCTIONS FOR CAM-BOLT & CAM-LOCK



CAM-BOLT



CAM-LOCK

Tools Required

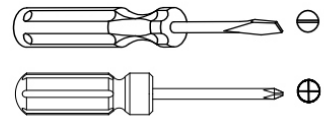

INSERTING AND TIGHTENING CAM-BOLT

Place Cam-bolt on pre-drilled hole and screw in vertically

Shoulder is flushed (on the same level) with the panel.

Shoulder is above the panel.

Place Cam-bolt on the designated pre-drilled hole on the panel. Use a Phillips Screwdriver to screw-in Cam-bolt vertically until shoulder is flushed (on the same level) with panel.

INSERTING CAM-LOCK

Insert Cam-lock with arrow align to Cam-bolt head

CORRECT

WRONG

Align the arrow on the Cam-lock to the Cam-bolt head and insert the Cam-lock. Ensure Cam-lock is fully inserted.

TIGHTENING CAM-LOCK

Use a Flat-head Screwdriver to turn Cam-lock clockwise so it locks onto the head of the Cam-bolt. Turn until it is snug (about 3/4ths of a turn) -- over-tightening could damage Cam-lock or/and Cam-bolt.

1

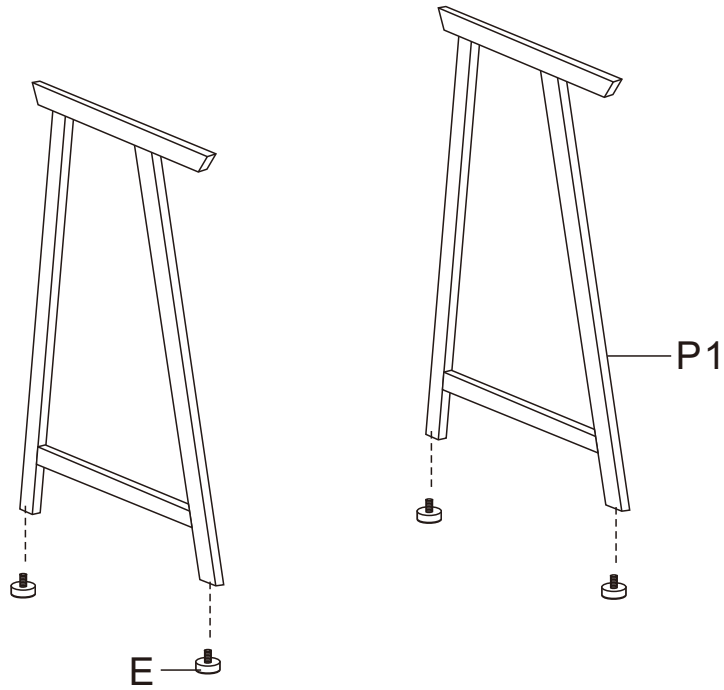

Screw in Leg Stud (E) at the end of each Leg Frame (P1) as shown.

2

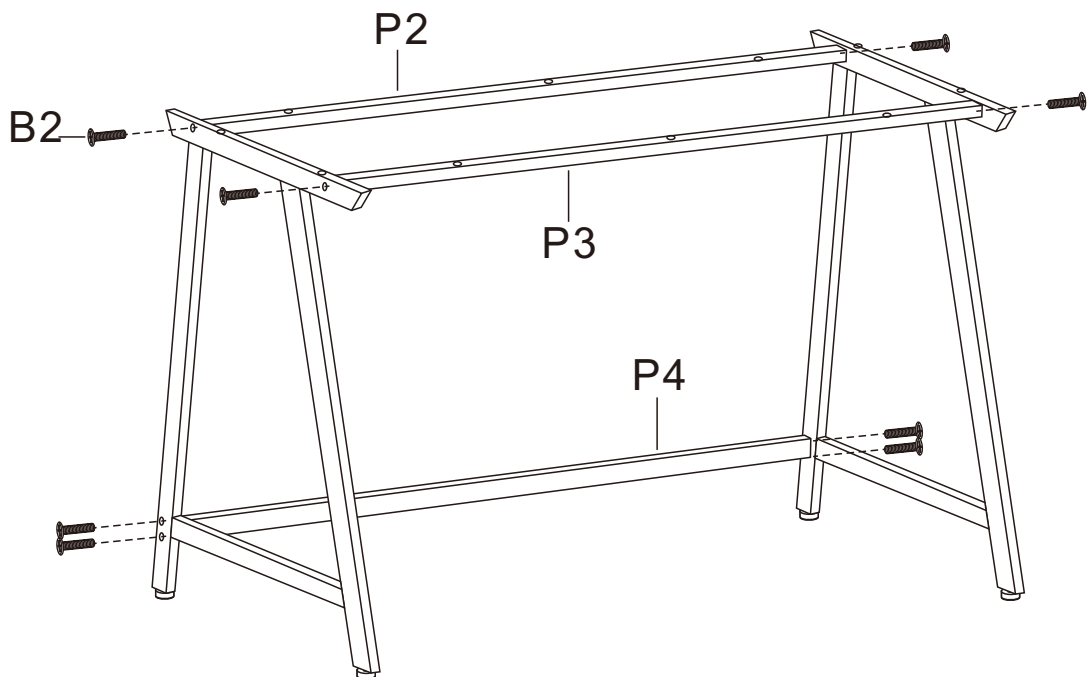

With assistance, place Rear & Front Table Support (P2 & P3) between Legs Frames (P1) and use Screw (B2) to fasten (P2 & P3) to (P1). Do not tighten (B2) completely at this time. Next, use Screw (B2) to fasten Leg Stretcher (P4) to the rear leg of (P1). Do not tighten these screws completely until all 4 screws are in place to fasten (P3). Tighten the screws used to fasten (P2 & P3) completely at this time.

3

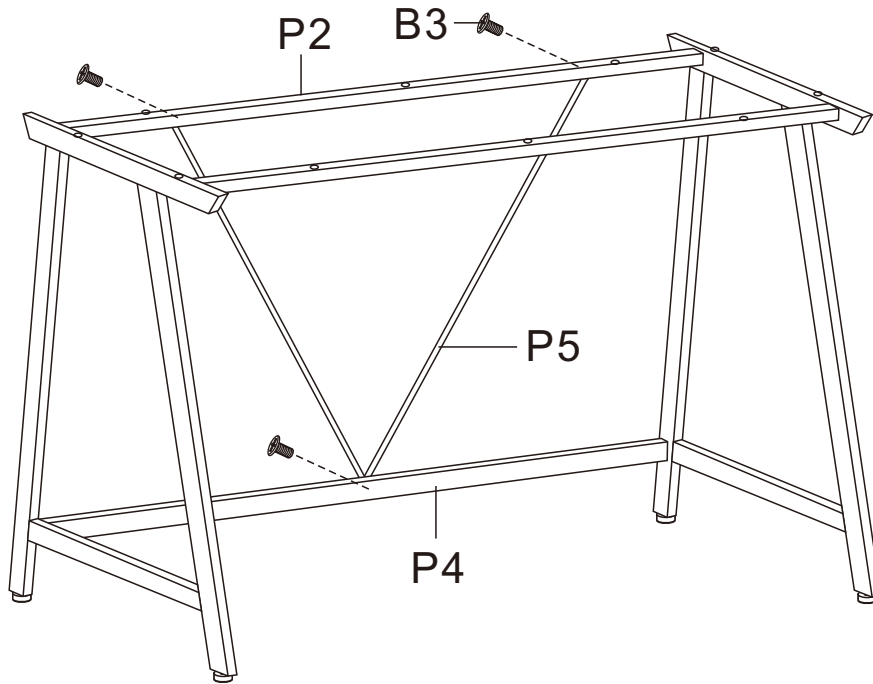

Use Screw (B3) to fasten Vertical Stretchers (P5) to Rear Table Support (P2) and Leg Stretcher (P4).

4

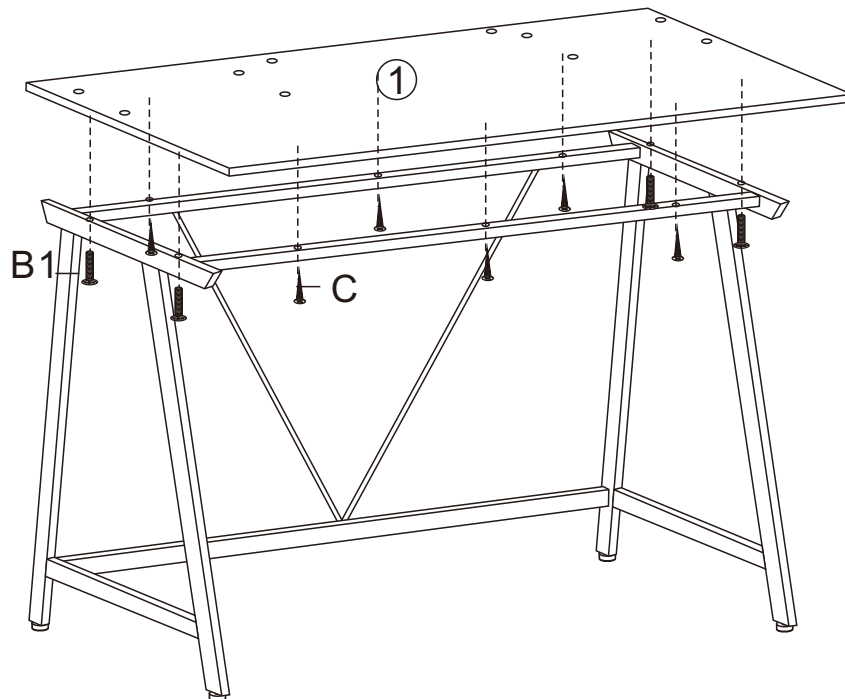

Place Desk Top Panel (1) to align screw holes on (1) to screw holes on Leg Frames, Front and Rear Table Support.

Next, Use Screws (B1) to fasten (1) to Leg Frames, and Screw (C) to fasten (1) to Front and Rear Table Support. Do not tighten (B1 and C) completely until all of the screws are in place.

5

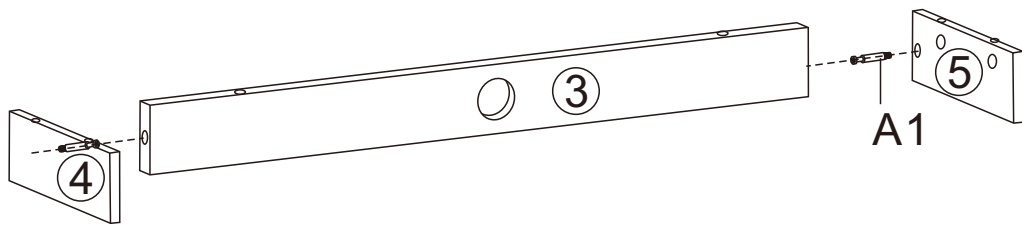

- Position Shelf Rear Panel (3), Shelf Left Panel (4) and Shelf Right Panel (5) as shown.
- Screw in Cam-bolt (A1) into the designated hole on (4 & 5). Refer to Page 3 for instructions on inserting and tightening Cam-bolts)
- Attach (4 & 5) to (3) via cam-bolt.
- Insert Cam-lock (A2) into the designated holes at the back of (3) and turn clockwise to lock onto cam-bolt. Refer to Page 3 for instructions on inserting and tightening Cam-locks.

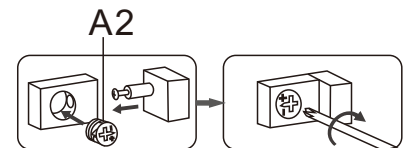

6

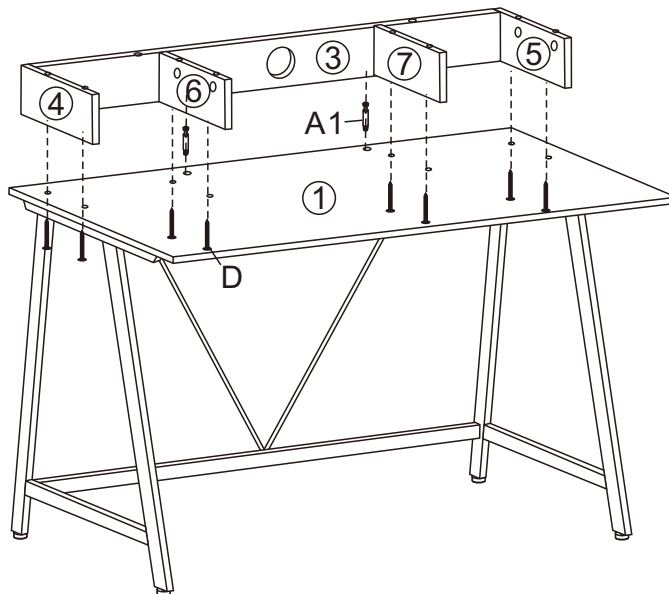

- Screw in Cam-bolt (A1) into the designated holes at the rear edge of Desk Top Panel (1).
- Attach assembly (3, 4 & 5) from Step 5 to (1) via cam-bolts on (1).
- Insert Cam-lock (A2) into the designated holes at the back of (3) and turn clockwise to lock onto cam-bolt.
- Align screw holes on Shelf Left and Right Panel (4 & 5) to screw holes on (1) and fasten with Screw (D). Do not tighten (D) until both screws are in place on each panel.
- Align screw holes on Inner Shelf Left Panels (6 & 7) to the corresponding screw holes on (1). Note the holes for cam-lock on (6 & 7) are facing 4 & 5), respectively. Use Screw (D) to fasten (6 & 7) to (1). Do not tighten (D) completely until both screws are in place on each panel.

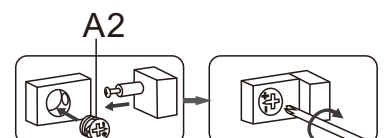

7

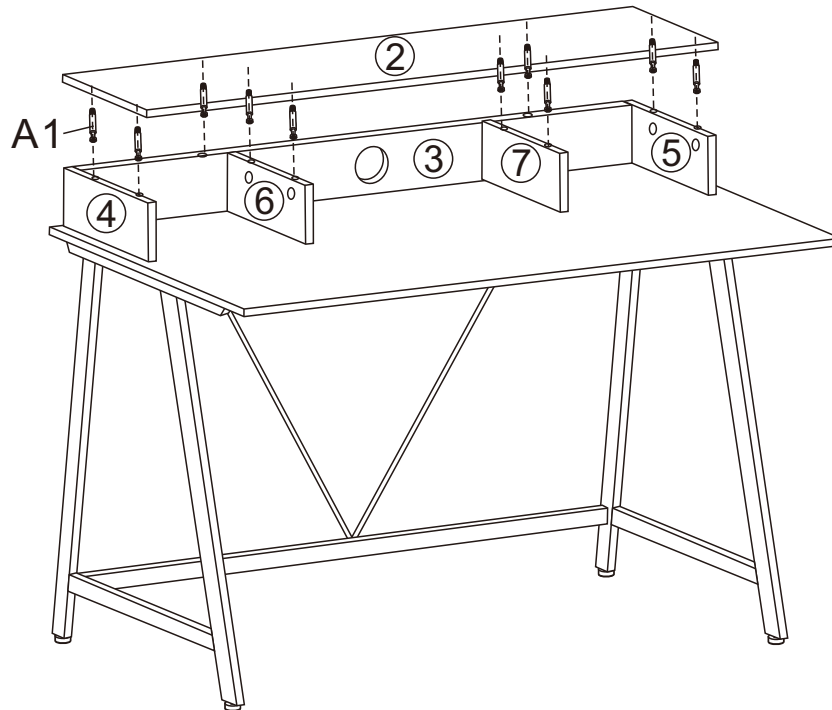

- Screw in Cam-bolt (A1) into the designated holes on (3, 4, 5, 6 & 7).
- Attach Shelf Top Panel (2) to (3, 4, 5, 6 & 7) via cam-bolts.
- Insert Cam-lock (A2) into the designated holes on (3, 4, 5, 6 & 7) and turn clockwise to lock onto cam-bolt.

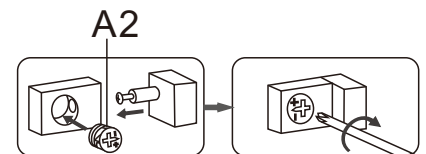

8

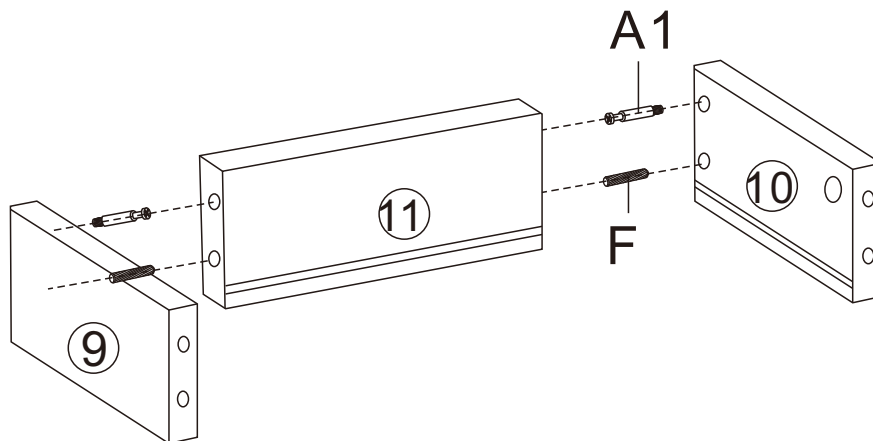

- Position Drawer Rear Panel (11), Drawer Left Panel (9) and Drawer Right Panel (10) as shown. Note the groove on each panel is at the bottom. Screw in Cam-bolt (A1) into the upper hole on (9 & 10) and insert Wood Dowel (G) into the lower hole.
- Attach (9 & 10) to (11) via cam-bolt and wood dowel.
- Insert Cam-lock (A2) into the designated holes at the back of (11) and turn clockwise to lock onto cam-bolt.

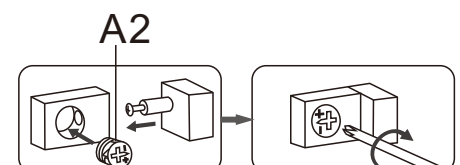

9

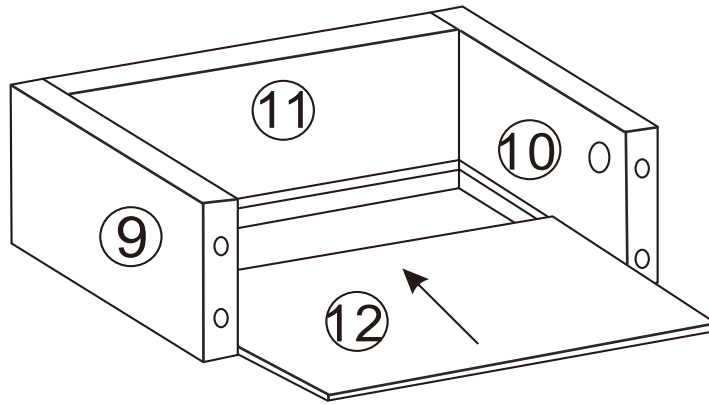

Fit Drawer Bottom Panel (12) via groove on (9, 10 & 11).

10

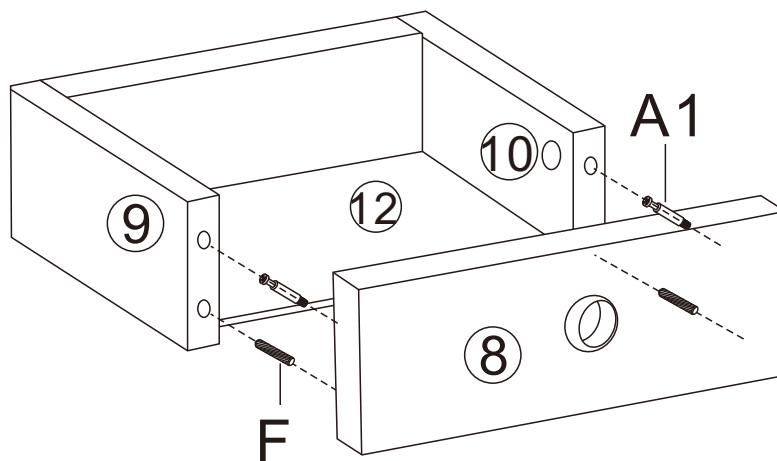

- Screw in Cam-bolt (A1) into the upper hole on Drawer Front Panel (8) and insert Wood Dowel (G) into the lower hole.
- Attach (8) to (9 & 10) to (11) via cam-bolt and wood dowel. Check that Drawer Bottom Panel (12) fits into the groove on the inside-face of (8).
- Insert Cam-lock (A2) into the designated hole on (9 & 10) and turn clockwise to lock onto cam-bolt.

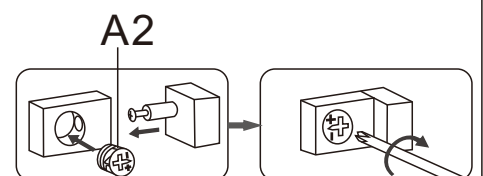

11

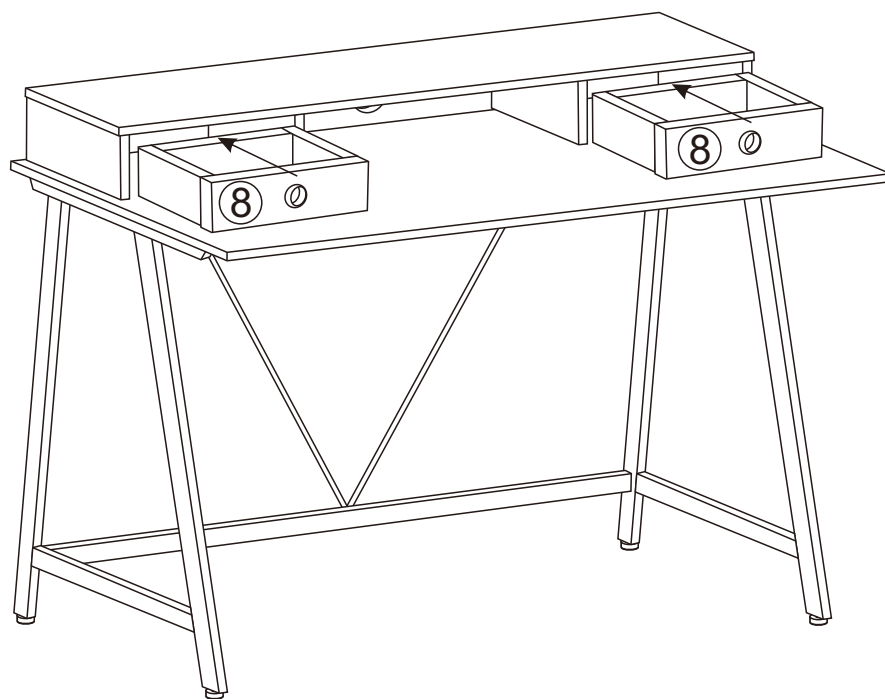

Insert the completed drawers in Step 10 into drawer compartment.

12

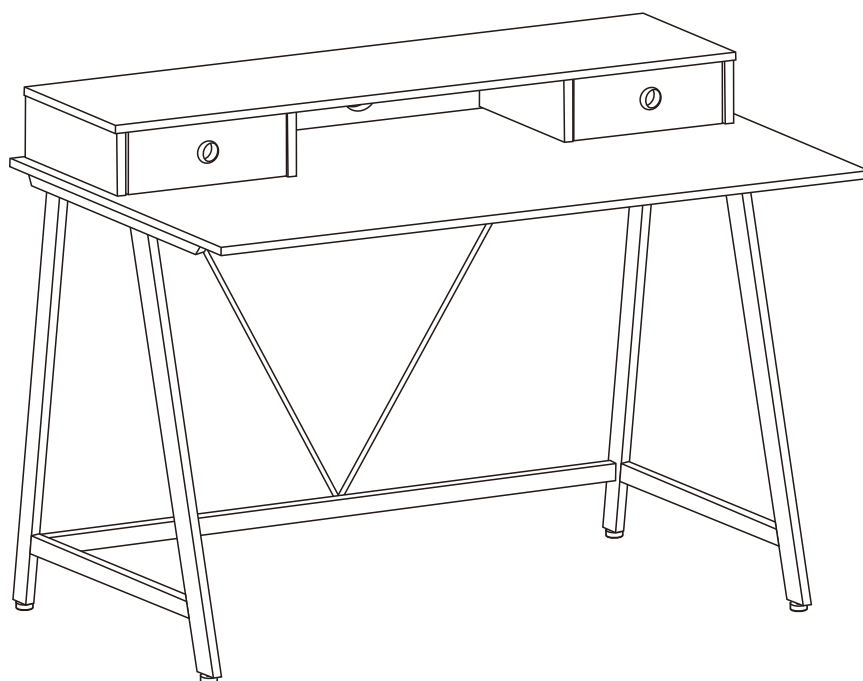

The assembly of the desk is complete.