

Assembly Instruction of (Cabinet)

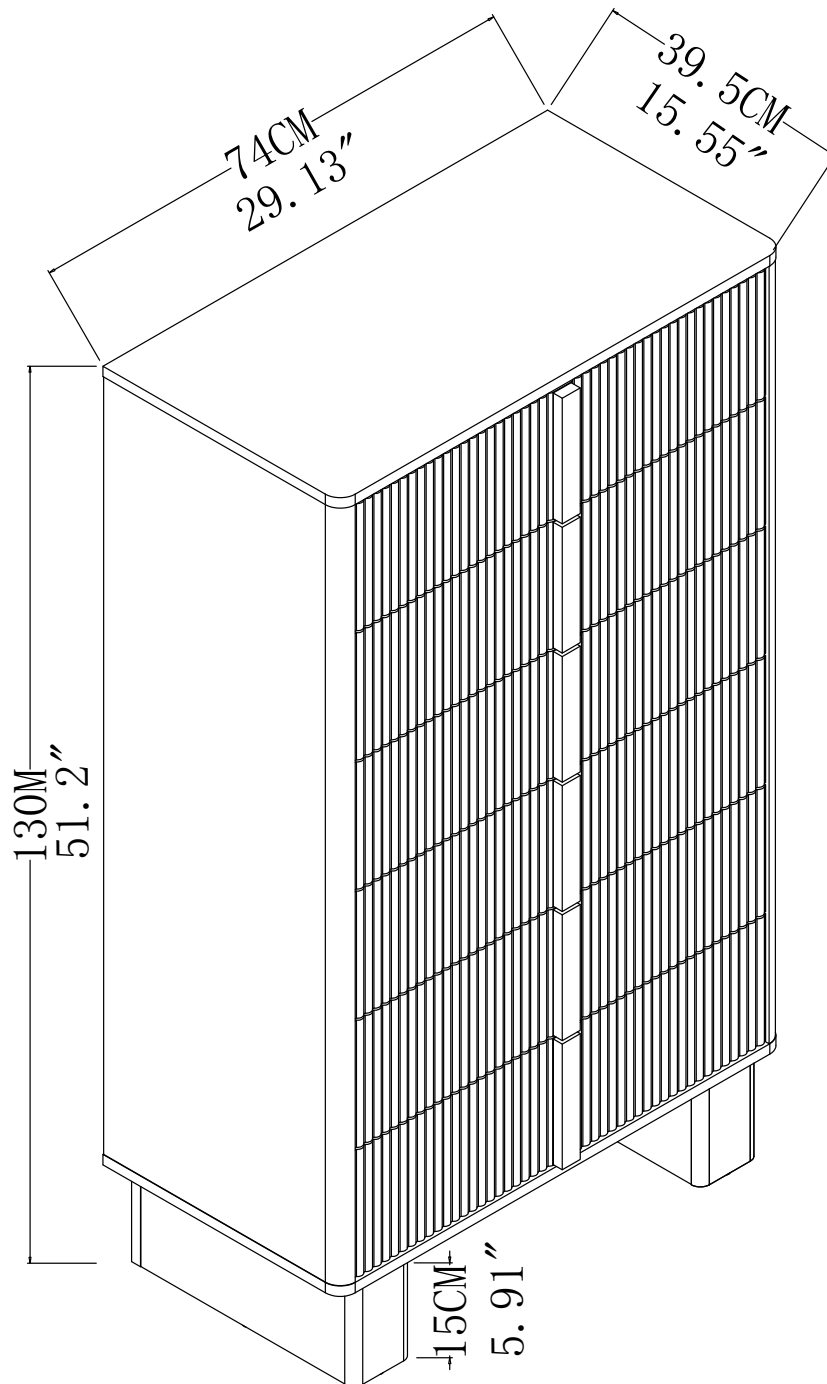

Contact Us

We're here to help you.

Your satisfaction is our top priority. If you encounter any issues with this product, such as missing or damaged parts, we're here to help. Please retain the original packaging and take photos of the packaging and the product, then contact us as soon as possible.

Warm Tips

1. Carefully read these instructions and keep them for future reference.
2. Check the parts list and confirm everything's there before starting assembly.
3. When assembling, put all parts on a soft, smooth surface like a carpet to avoid scratches.
4. Don't fully tighten screws until all parts are confirmed in place to avoid misalignment.
5. 1 year coverage. We offer 1 year coverage on our product against any technical defects. If you experience any issues, please reach out to our customer service team for prompt assistance.

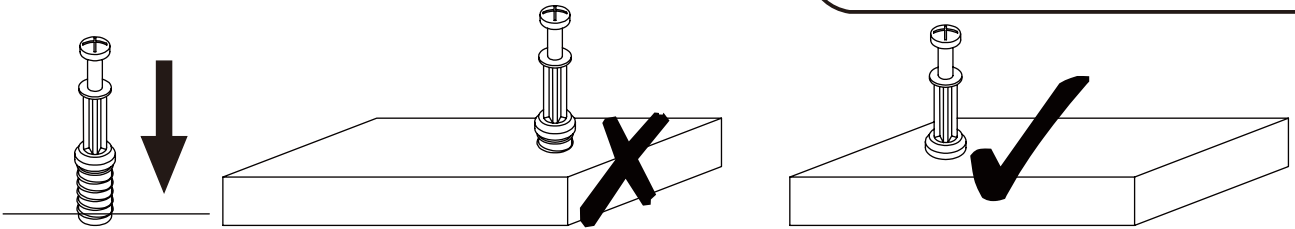

EN_QUICKFIT: Tighten the Quickfit until the head is flush with the panel. Do not over-tighten or under-tighten.

FR_RACCORD RAPIDE: Faites serrer le raccord rapide jusqu'à ce que l'épaulement soit parfaitement encastré dans le panneau. Il ne faut ni trop serrer ni insuffisamment serrer.

ES_QUICKFIT: Apriete quickfit hasta que el hombro se descargue con el panel. NO lo sobreapriete ni lo apriete poco.

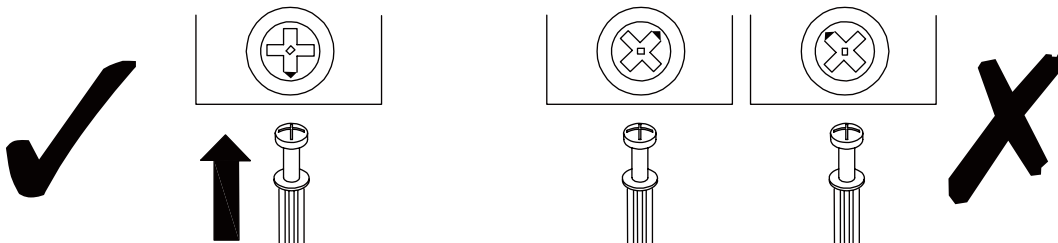

EN_CAM LOCK: When fitting cam lock, ensure starting position is correct before you insert connecting quickfit.

FR_SERRURE BATTEUSE: Avant d'insérer la serrure batteuse, veillez à la bonne orientation avant d'insérer le raccord rapide.

ES_CIERRE DE LA CÁMARA: Cuando instale el cierre de la cámara, asegúrese de que la posición de inicio es correcta antes de que inserte el quickfit conector.

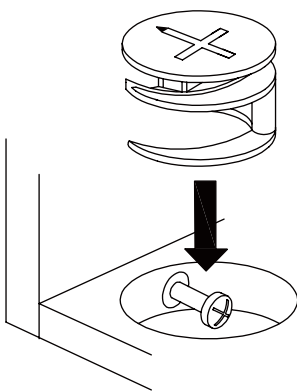

EN_Quickfit head should be in the centre of the cam lock when the two panels are joined.

The cam lock must be inserted before the Quickfit.

FR_Lorsque les deux panneaux sont assemblés, la tête du raccord rapide doit reposer au centre de la serrure batteuse.

Il faut insérer la serrure batteuse avant le raccord rapide.

ES_El cabezal del quickfit debe estar en el centro del cierre de la cámara cuando se unan los dos paneles.

Se debe insertar el cierre de la cámara antes que el quickfit.

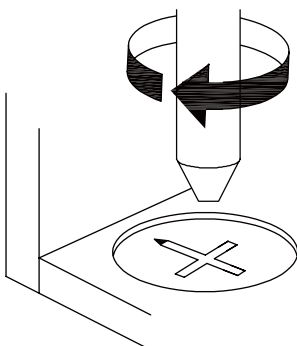

EN_Turn cam lock clockwise to tighten.

FR_Faites tourner la serrure batteuse dans le sens des aiguilles d'une montre pour la resserrer.

ES_Gire el cierre de la cámara en sentido horario para apretarlo.

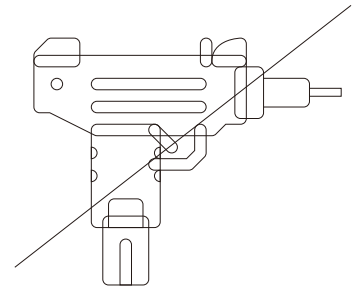
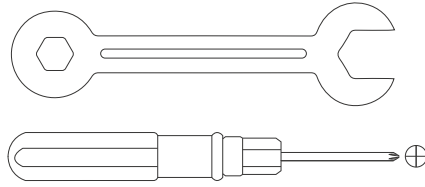
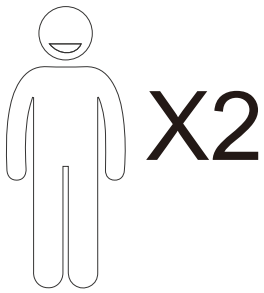

We recommend using hand tools for assembly.

If an electric screwdriver is used, reduce power and torque to avoid damage to the product.

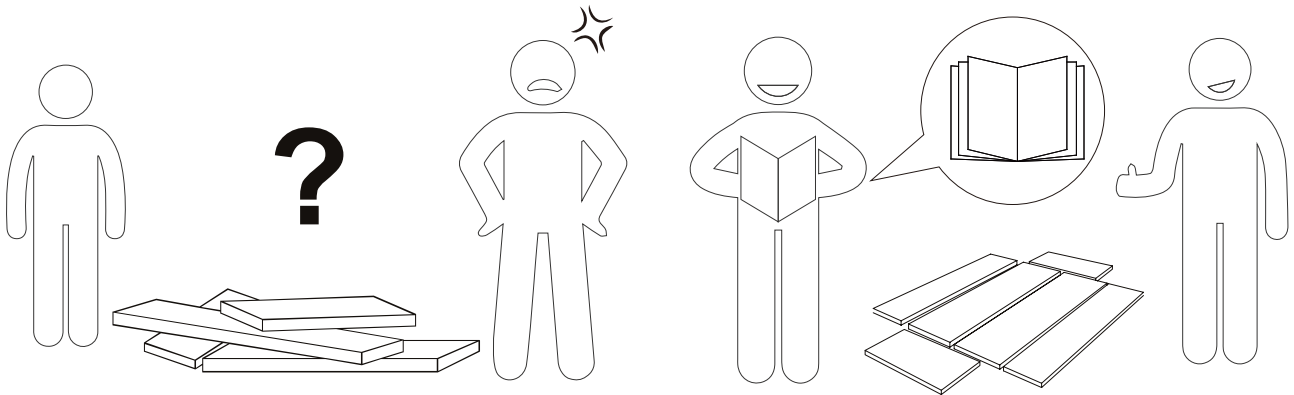

Install the Anti-Tip Device

Using the anti-top device can reduce the risk of tipping over, but can not eliminate it.

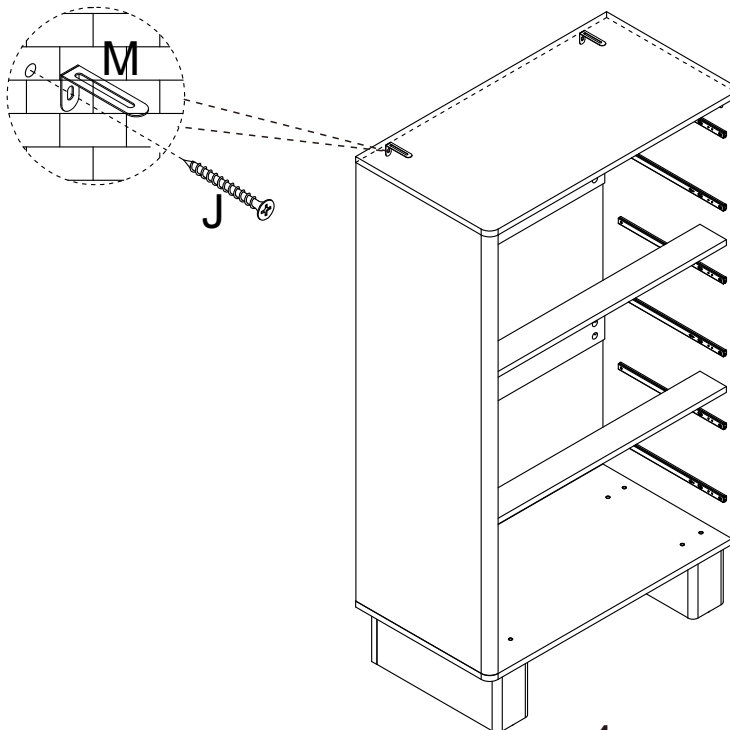



[EN]

Warning: Please read instructions fully before starting assembly. Check that you have all components and tools listed on the following pages.

Warning: Please place all parts on a flat surface. Place a soft blanket or similar underneath to protect against scratches or stains. Avoid dragging or sliding parts across the floor.

Warning: Regularly check all fittings and fastenings to ensure they are secure and to prevent accidents. If any parts are missing, broken, damaged, or worn, discontinue use of the product until repairs have been made using factory authorized parts.

Warning: Do not allow children to climb on the furniture as this may result in tipping and serious personal injury. Assemble the furniture away from the reach of children.

Warning: Do not place furniture close to fire sources or high-temperature objects to avoid the risk of fire.

Warning: Clean furniture with a damp cloth or alcohol, avoid using cleaning agents containing corrosive chemicals.

Warning: This product is equipped with an anti-tip device. Please be sure to install this device to prevent unnecessary injuries caused by tipping.

[FR]

Avertissement : Veuillez lire entièrement les instructions avant de commencer l'assemblage. Vérifiez que vous disposez de tous les composants et outils répertoriés sur les pages.

Avertissement : Veuillez placer toutes les pièces sur une surface plane. Placez une couverture douce ou similaire en dessous pour les protéger des rayures ou des taches. Évitez de faire glisser les composants sur le sol.

Avertissement : Vérifiez régulièrement tous les raccords et fixations pour vous assurer qu'ils sont bien fixés et pour éviter les accidents. Si des pièces manquent, sont cassées, endommagées ou usées, cessez d'utiliser le produit jusqu'à ce que des réparations aient été effectuées à l'aide de pièces autorisées par l'usine.

Avertissement : Ne laissez pas les enfants grimper sur les meubles car cela pourrait entraîner un basculement et des blessures graves. Assemblez les meubles hors de portée des enfants.

Avertissement : Ne placez pas les meubles à proximité de sources de feu ou d'objets à haute température pour éviter tout risque d'incendie.

Avertissement : Nettoyez les meubles avec un chiffon humide ou de l'alcool, évitez d'utiliser des produits de nettoyage contenant des produits chimiques corrosifs.

Avertissement : Ce produit est équipé d'un dispositif anti-basculement. Assurez-vous d'installer ce dispositif pour éviter les blessures inutiles causées par un basculement.

[ES]

Advertencia: Lea las instrucciones completamente antes de comenzar el montaje. Compruebe que tiene todos los componentes y herramientas que se enumeran en las páginas.

Advertencia: Coloque todas las piezas sobre una superficie plana. Coloque una manta suave o algo similar debajo para protegerlas de rayones o manchas. Evite arrastrar o deslizar los componentes por el piso.

Advertencia: Verifique regularmente todos los accesorios y fijaciones para asegurarse de que estén seguros y evitar accidentes. Si falta alguna pieza, está rota, dañada o desgastada, deje de usar el producto hasta que se hayan realizado las reparaciones con piezas autorizadas de fábrica.

Advertencia: No permita que los niños se suban a los muebles, ya que esto puede provocar que se vuelquen y lesiones personales graves. Monte los muebles fuera del alcance de los niños.

Advertencia: No coloque los muebles cerca de fuentes de fuego u objetos de alta temperatura para evitar el riesgo de incendio.

Advertencia: Limpie los muebles con un paño húmedo o alcohol, evite usar agentes de limpieza que contengan químicos corrosivos.

Advertencia: Este producto está equipado con un dispositivo antivuelco. Asegúrese de instalar este dispositivo para evitar lesiones innecesarias causadas por vuelcos.

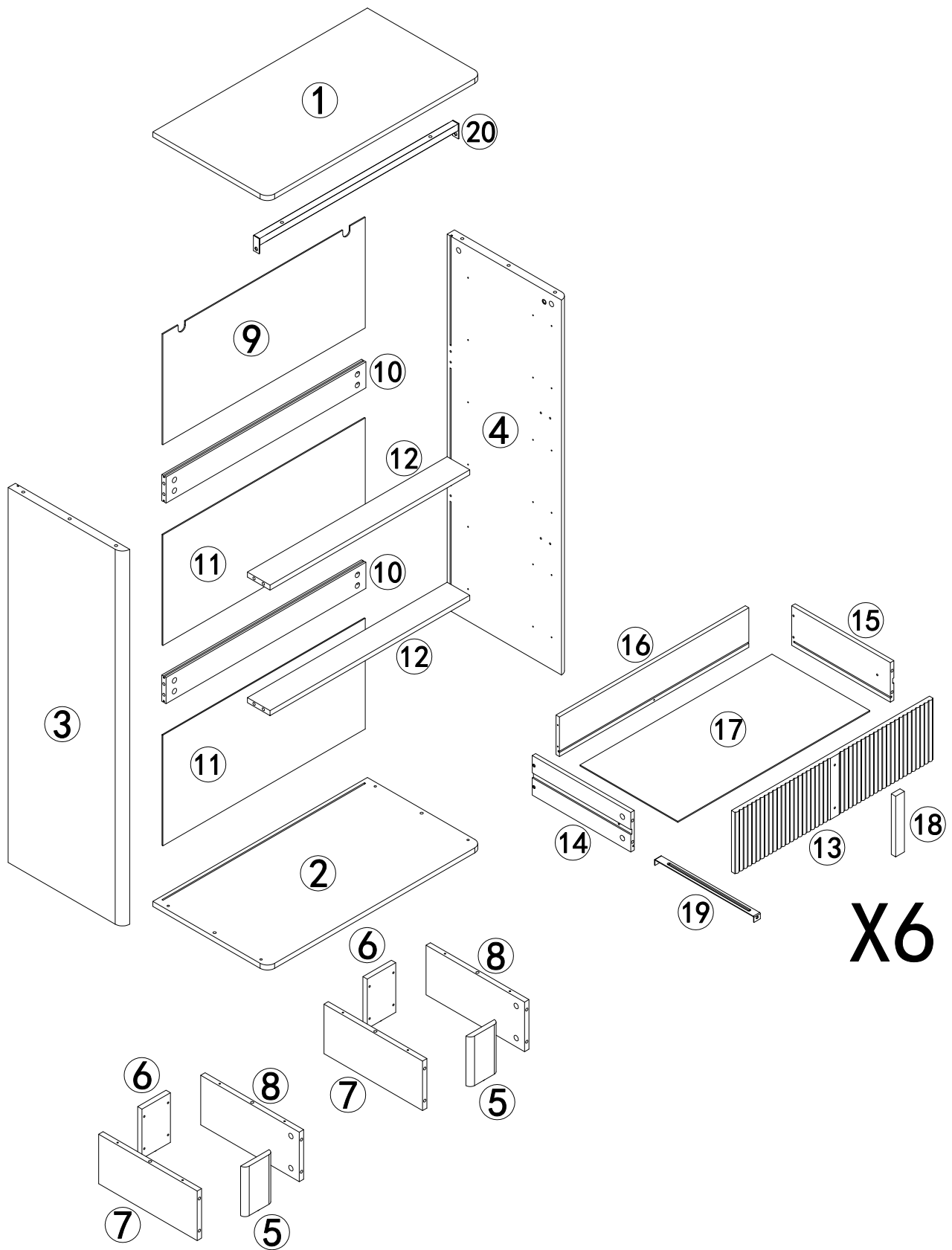



X6

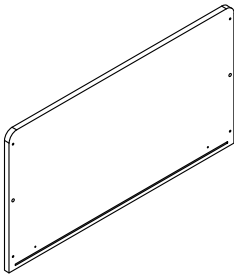
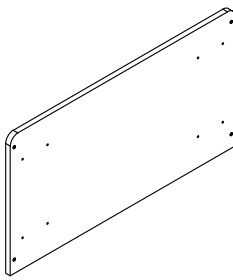
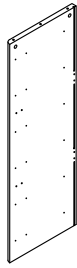
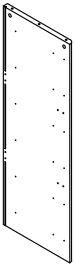
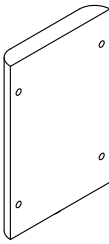
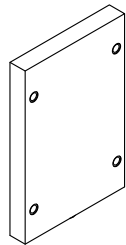
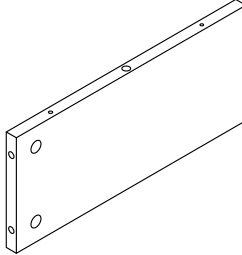
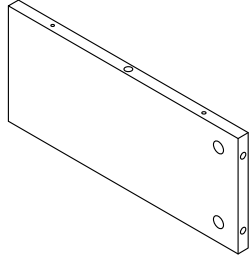
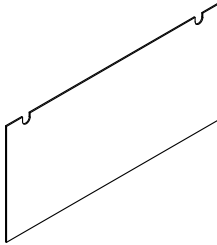
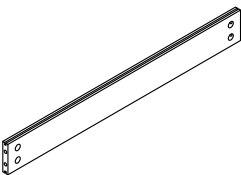
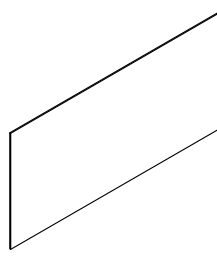
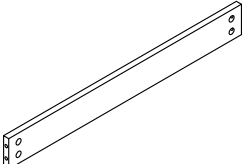
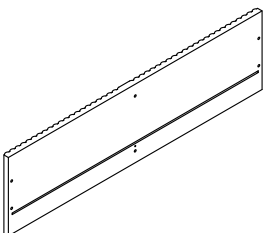
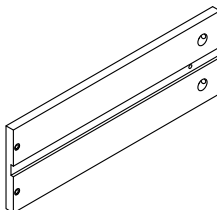
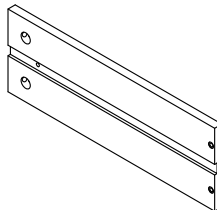
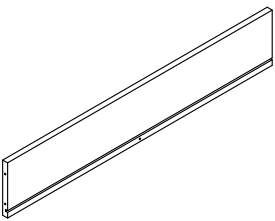
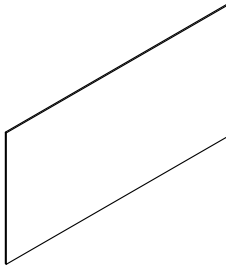

⚠ Caution

Please ensure all parts are included. Most board components are labeled or stamped on the raw edges. If you find any damaged or missing parts, feel free to contact us for a free replacement.

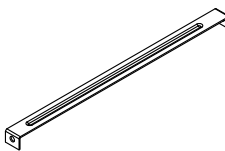
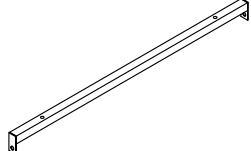
Parts List

			
1 1PC	2 1PC	3 1PC	4 1PC
			
5 2PCS	6 2PCS	7 2PCS	8 2PCS
			
9 1PC	10 2PCS	11 2PCS	12 2PCS
			
13 6PCS	14 6PCS	15 6PCS	16 6PCS
			
17 6PCS	18 6PCS	19 6PCS	20 1PC

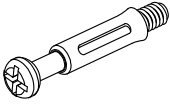
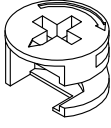
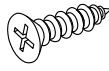
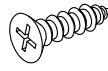
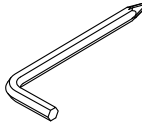
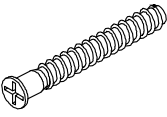
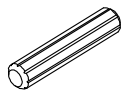
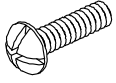
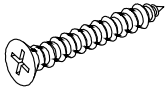
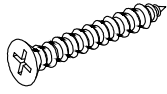
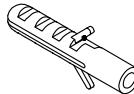
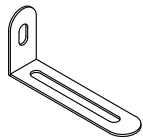
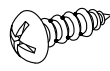
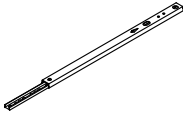
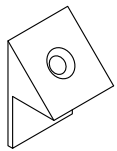
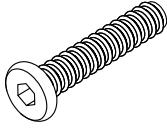
Hardware List

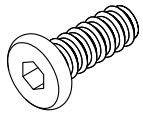
A	B	C	D	E	F
		 Silver Color M3.5x14mm	 Black Color M3x16mm		
M6x35mm	Ø15x9mm			4mm	M5x40mm
52PCS	52PCS	36PCS	12PCS	1PC	20PCS
G	H	I	J	K	M
					
Ø8x30mm	M4x10mm	M4x25mm	M4x35mm	Ø6x30mm	
8PCS	12PCS	12PCS	26PCS	2PCS	2PCS
N	O	P	Q	R	S
					
M4x12mm			M6x30mm	M3.5x12mm	M6x12mm
2PCS	12PCS	12PCS	2PCS	12PCS	2PCS

STEP 1



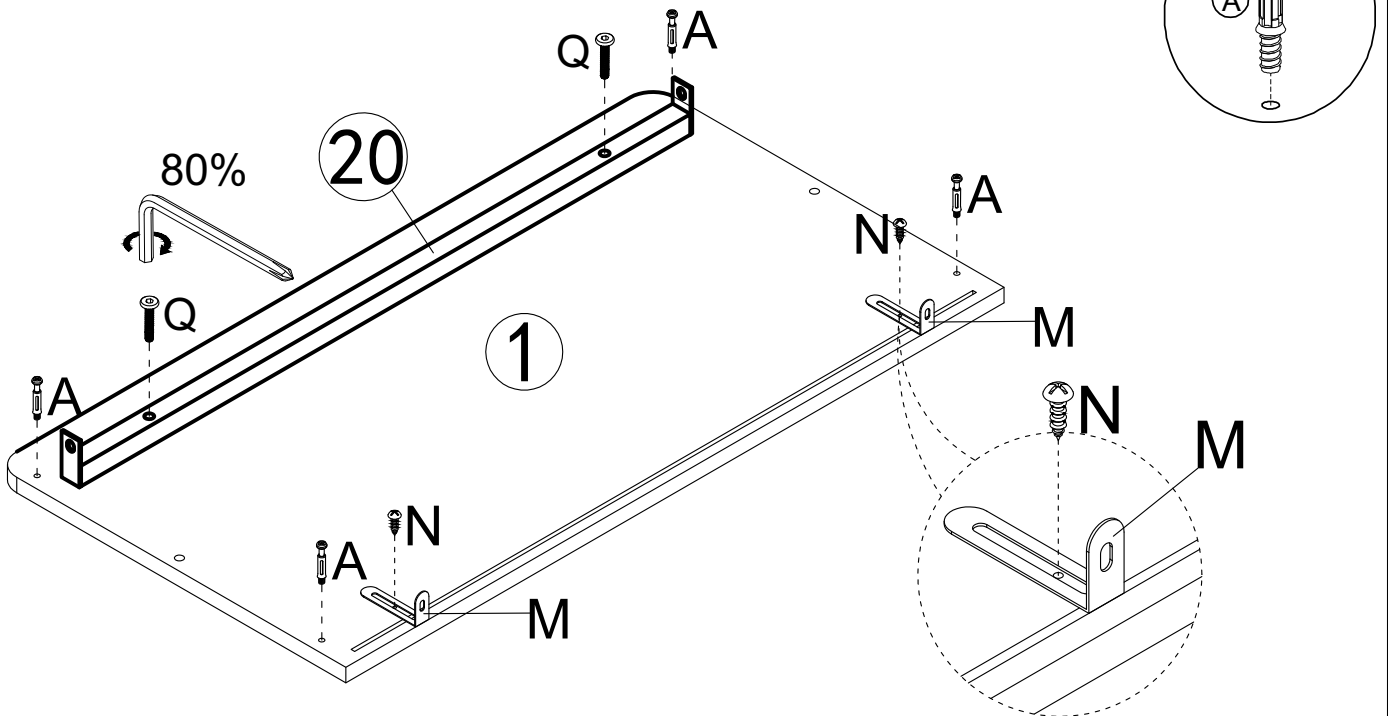

Tighten Screw Q
to 80% only, not 100%.



Ensure that your floor is properly protected.

Q	x2
	
M6x30mm	

A	x4
	
M6x35mm	

M	x2
	

N	x2
	
M4x12	

STEP 2

Ensure that your floor is properly protected.

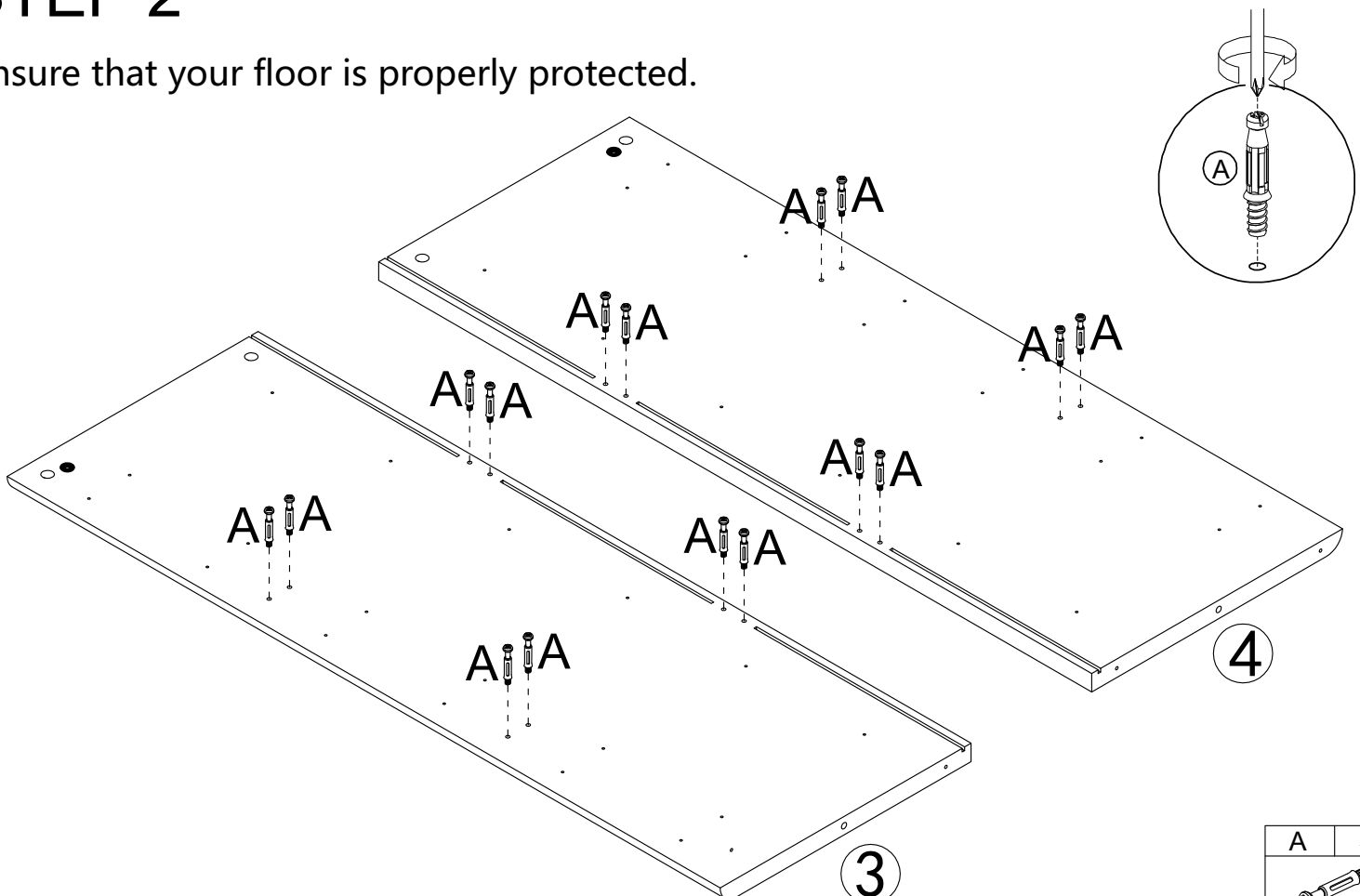

A	x16
	
M6x35mm	

STEP 3

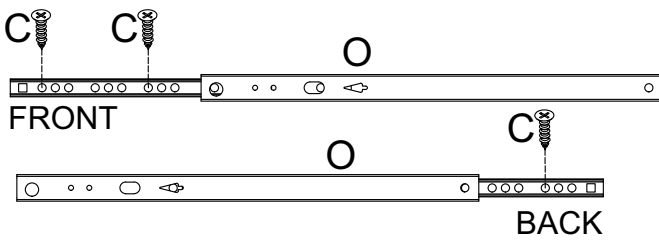

Step 3 and 4 will be completed on the same board #3.

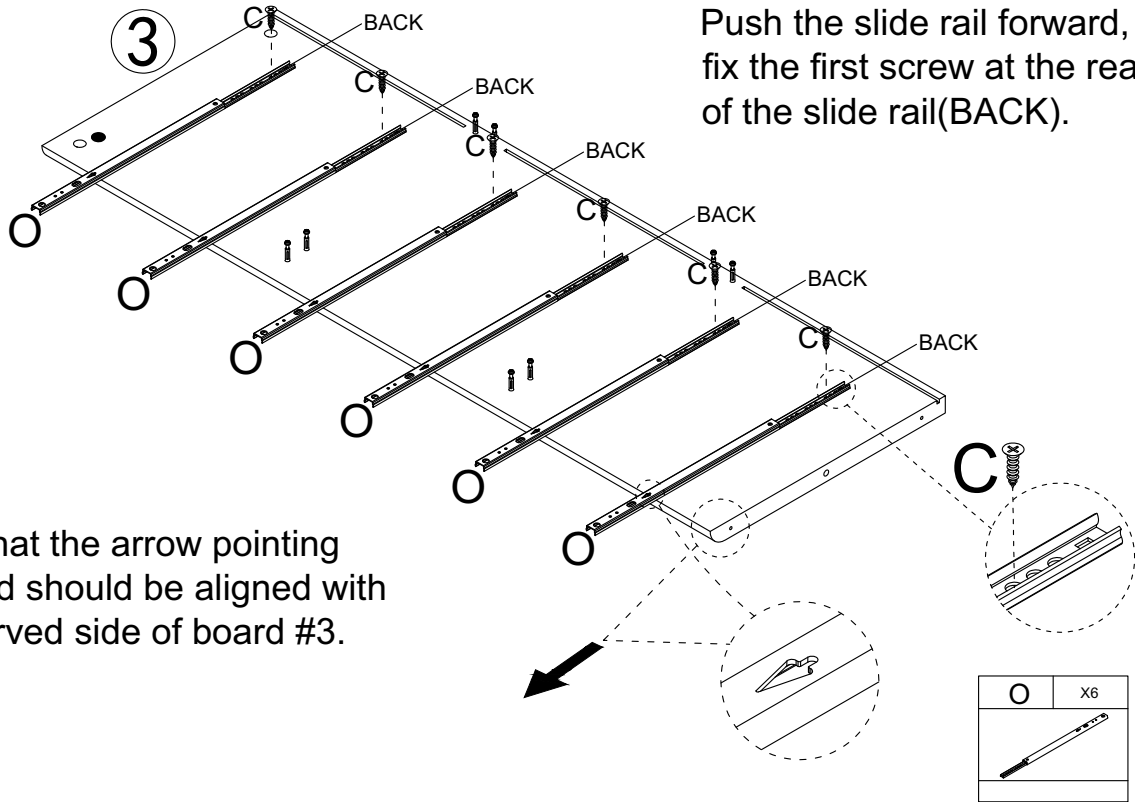

Note that the arrow pointing forward should be aligned with the curved side of board #3.

STEP 4

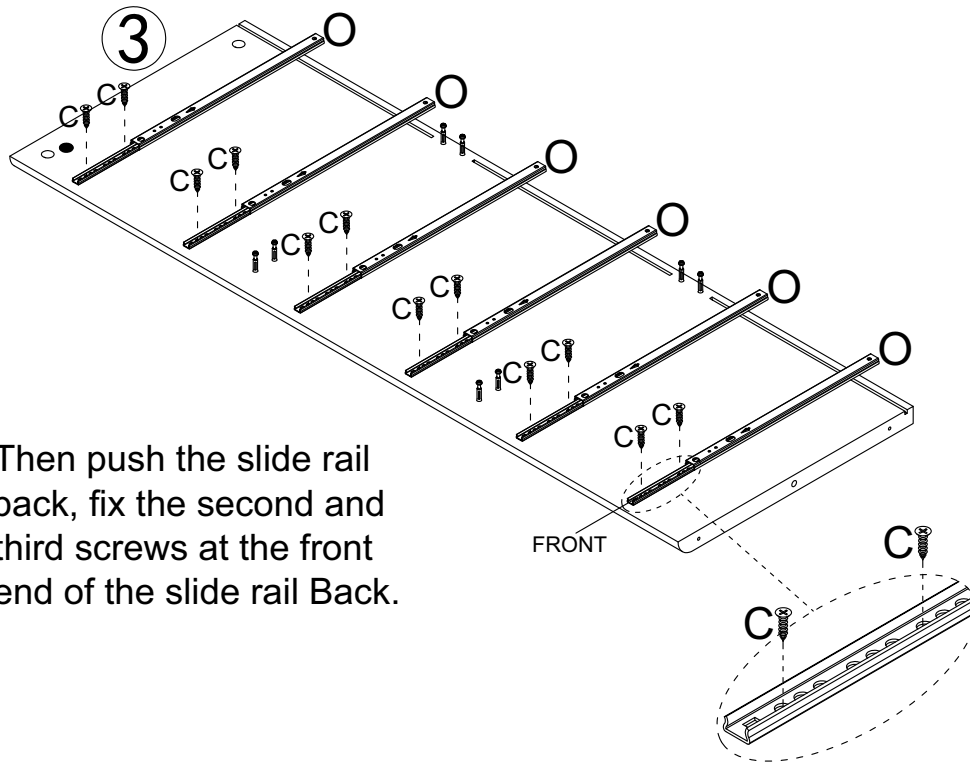

Then push the slide rail back, fix the second and third screws at the front end of the slide rail Back.

C	X12
	
M3.5x14mm	

STEP 5

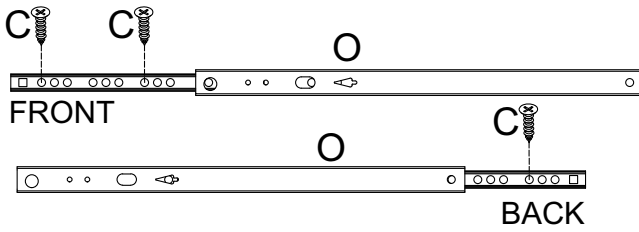

Step 5 and 6 will be completed on the same board #4.

Note that the arrow pointing forward should be aligned with the curved side of board #4.

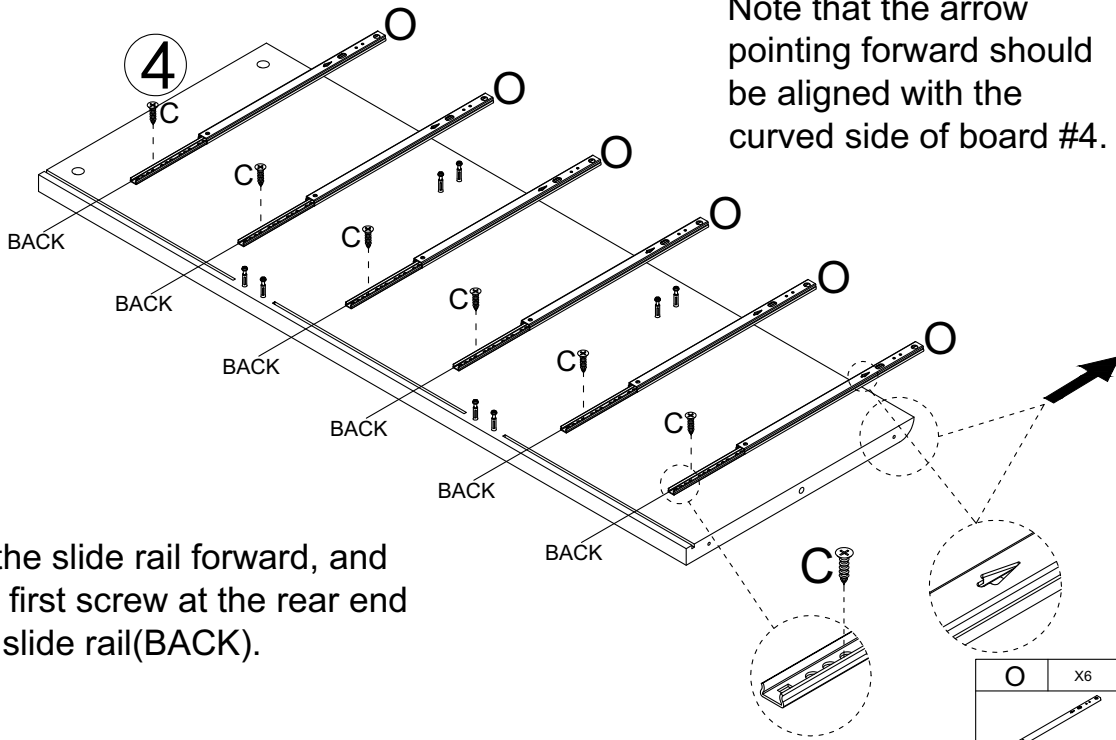

Push the slide rail forward, and fix the first screw at the rear end of the slide rail(BACK).

O	X6
C	X6
M3.5x14mm	

STEP 6

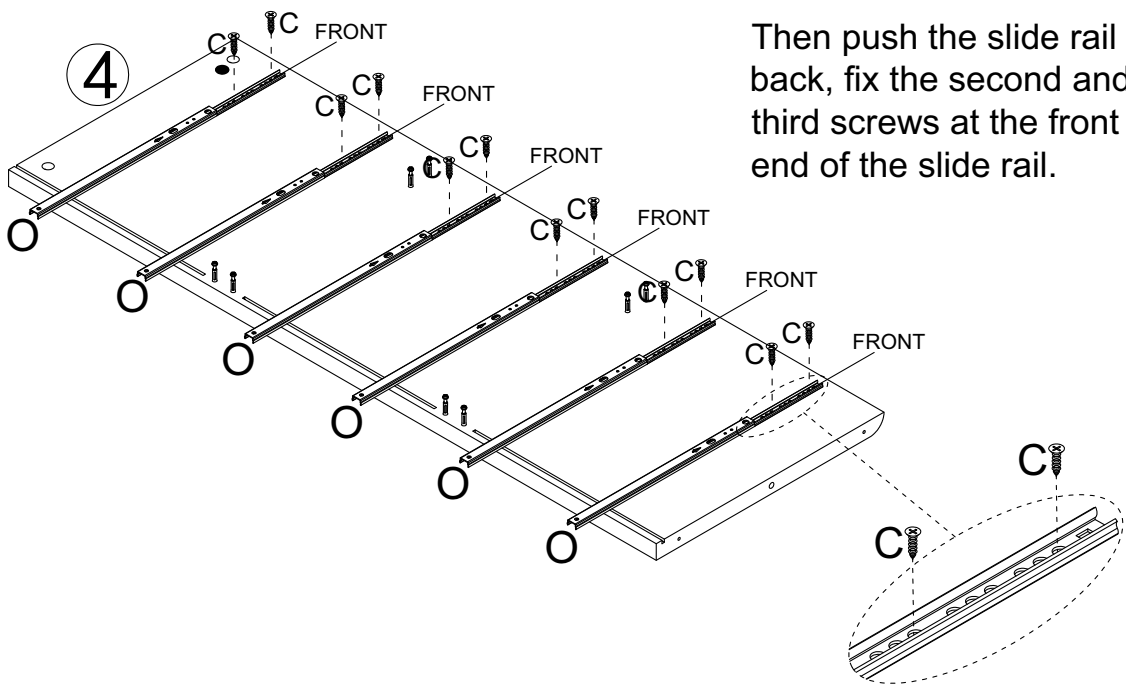

Then push the slide rail back, fix the second and third screws at the front end of the slide rail.

C	X12
M3.5x14mm	

STEP 7

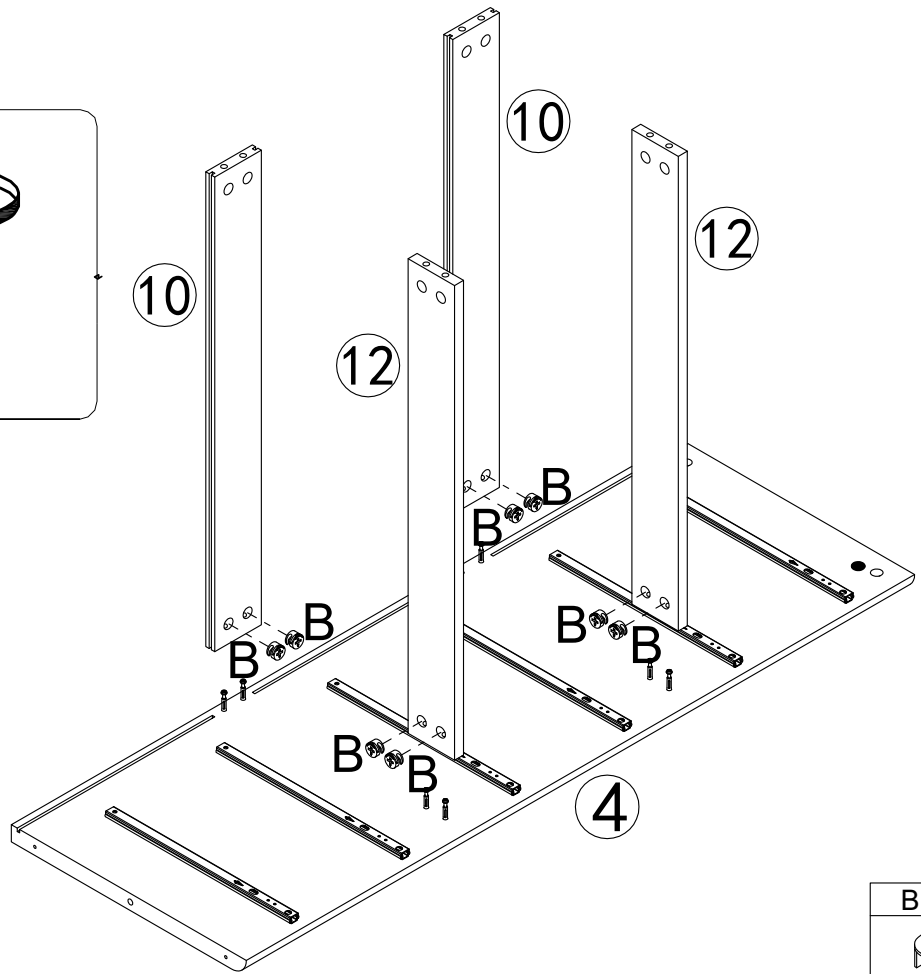
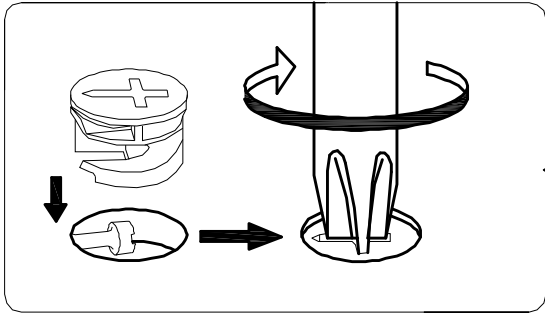

B	x8

STEP 8

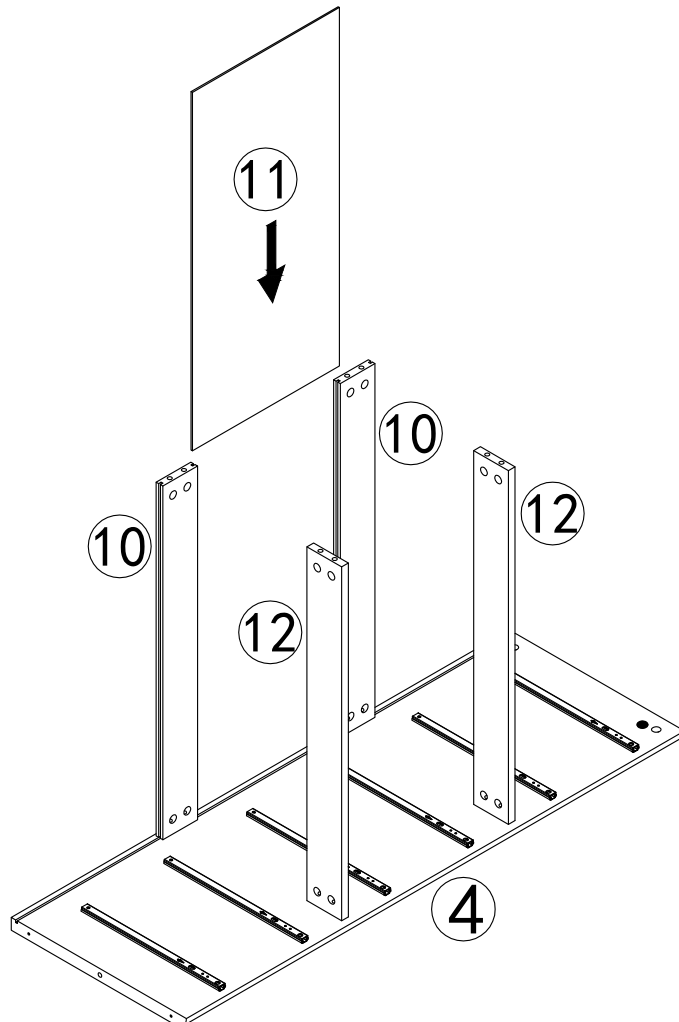

STEP 9

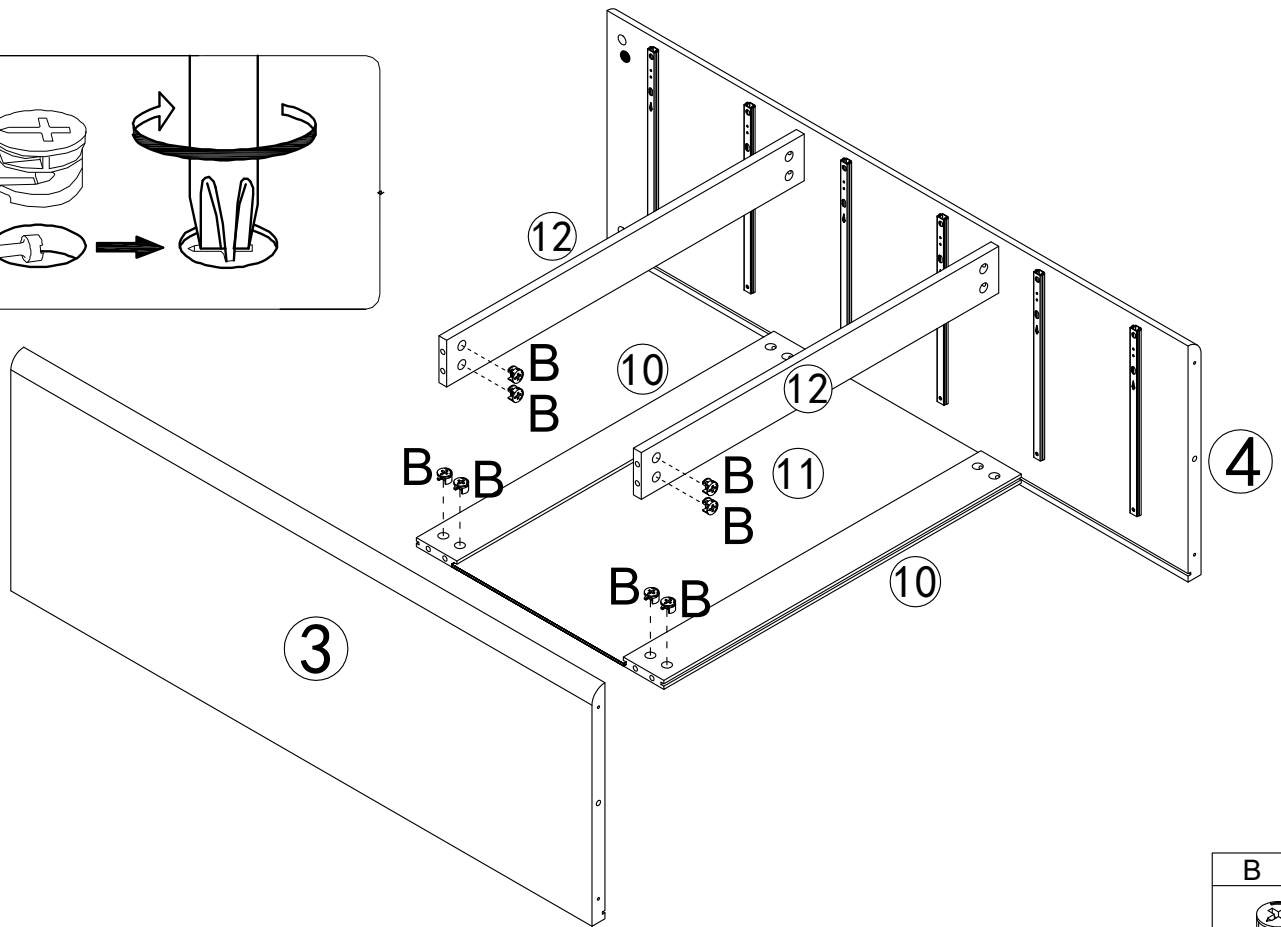
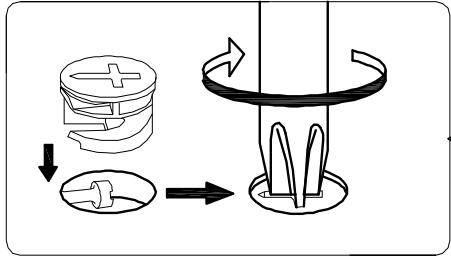

B	x8

STEP 10

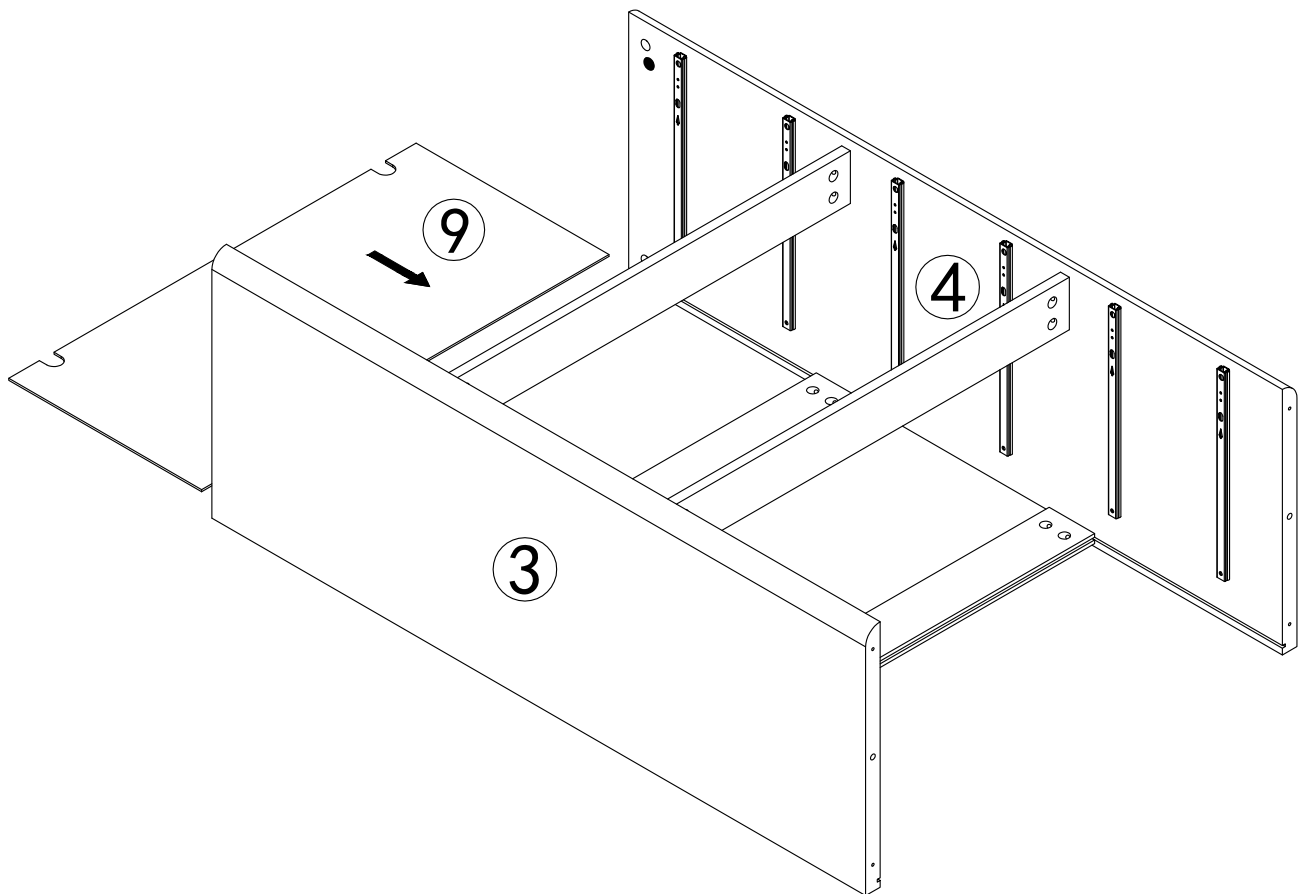

STEP 11

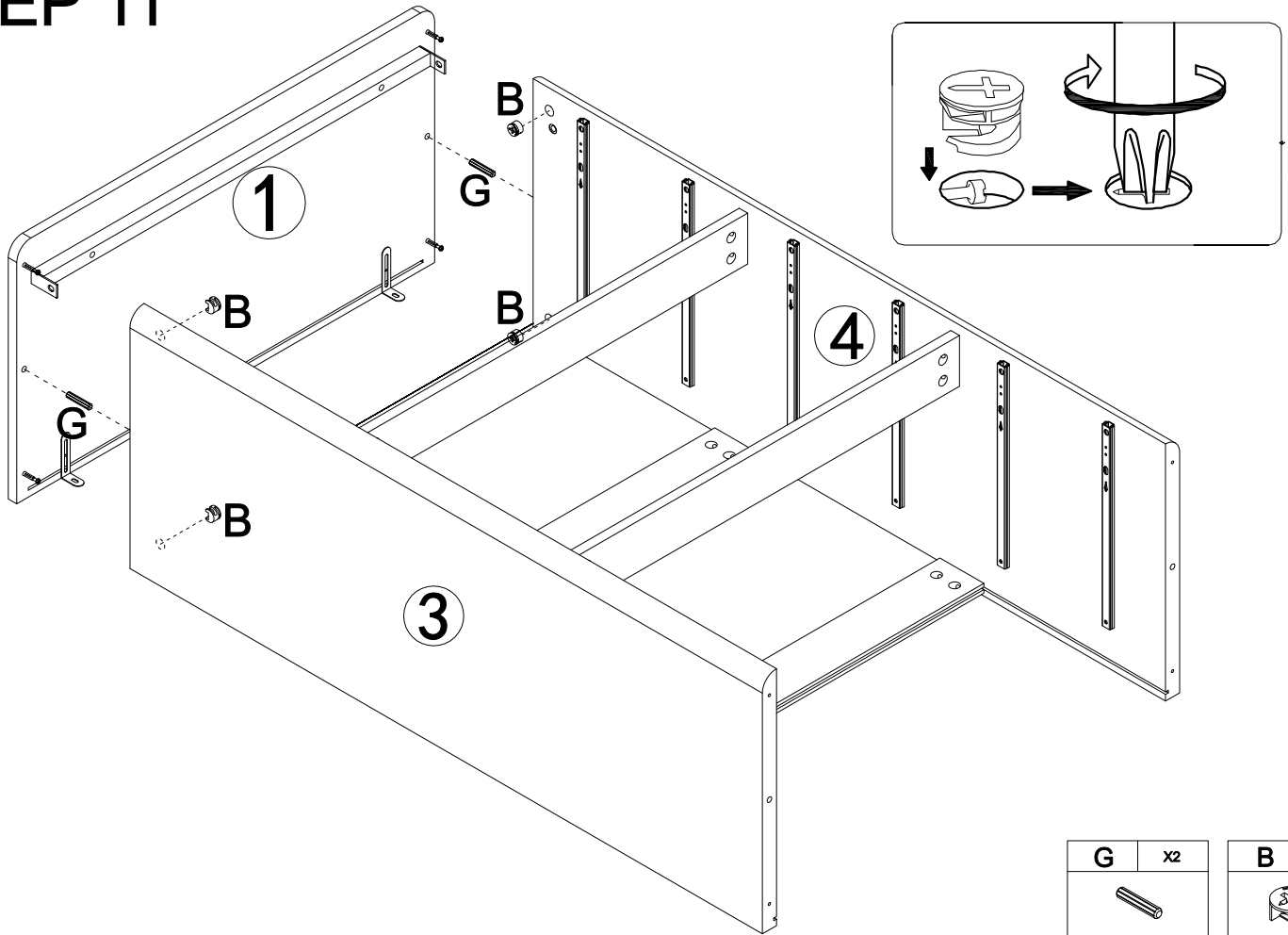

STEP 12



Tighten Screw Q to 100% after Screw S assembled.

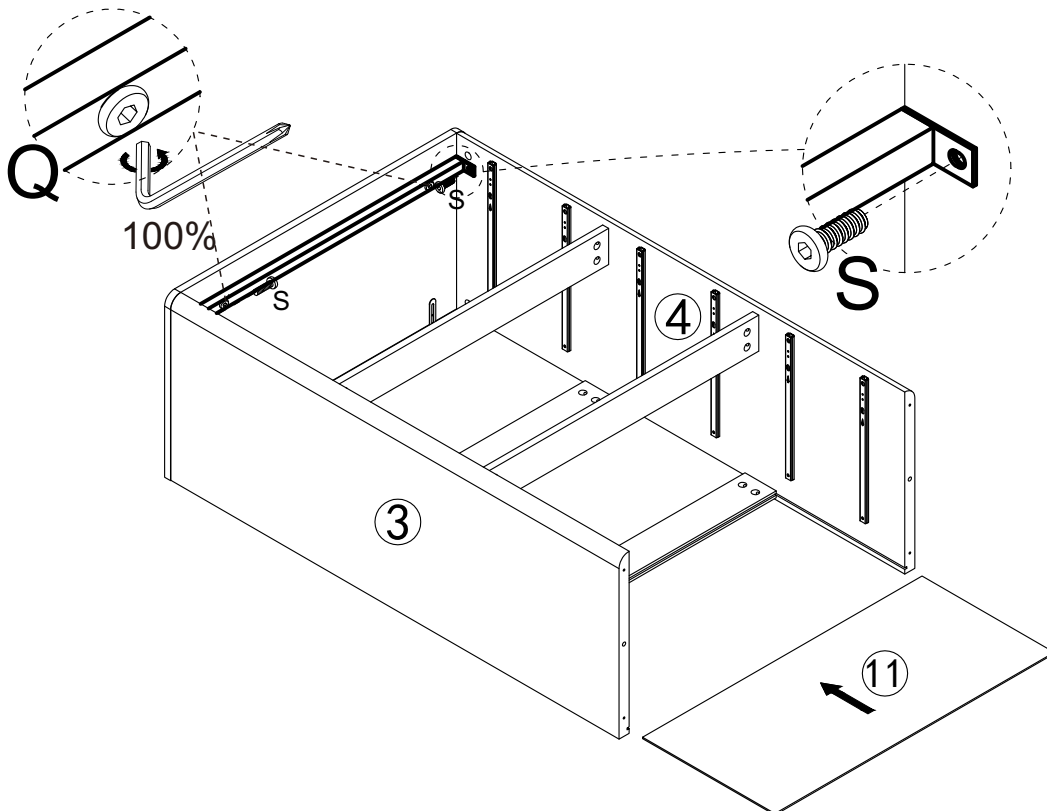

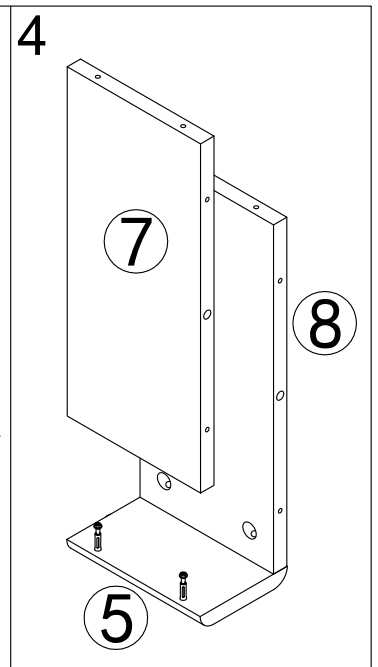
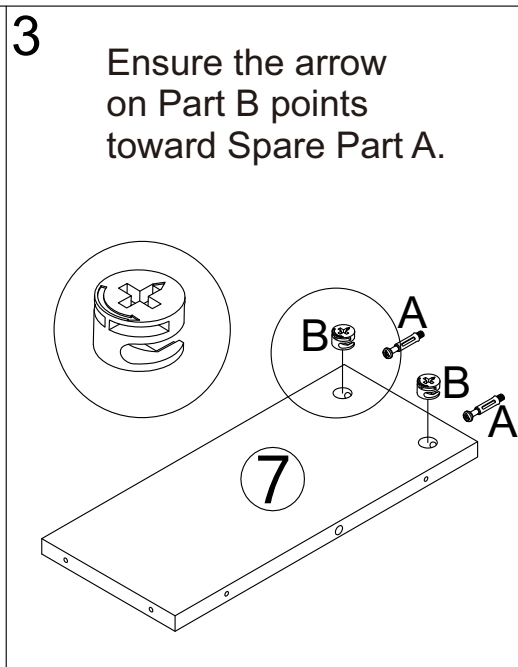
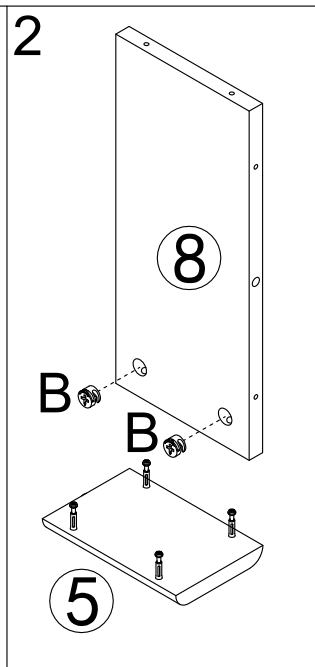
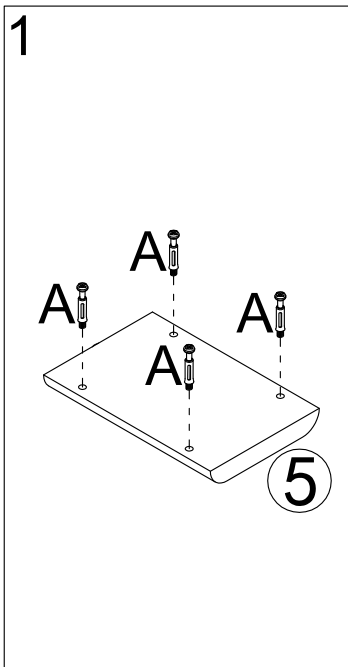
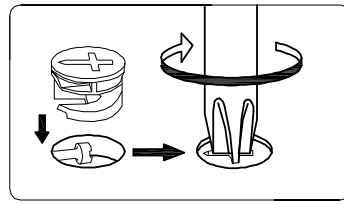
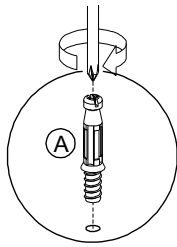

S	x2
	
M6x12mm	

STEP 13



X2

A	x8
	
M6x35mm	

B	x8
	

STEP 14

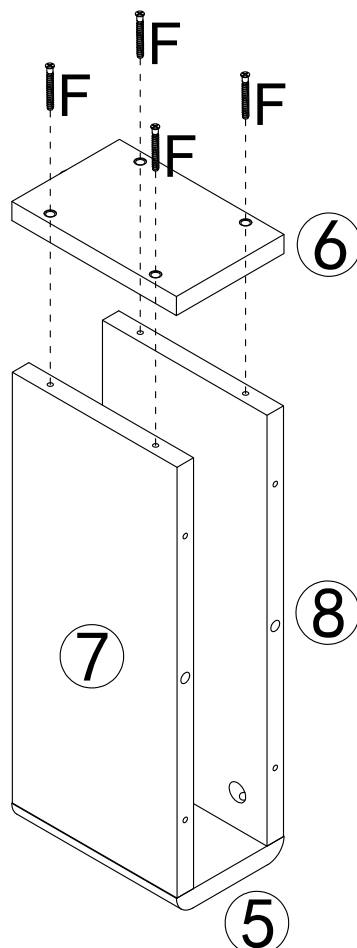



X2

F	x8
	
M5x40mm	

STEP 15

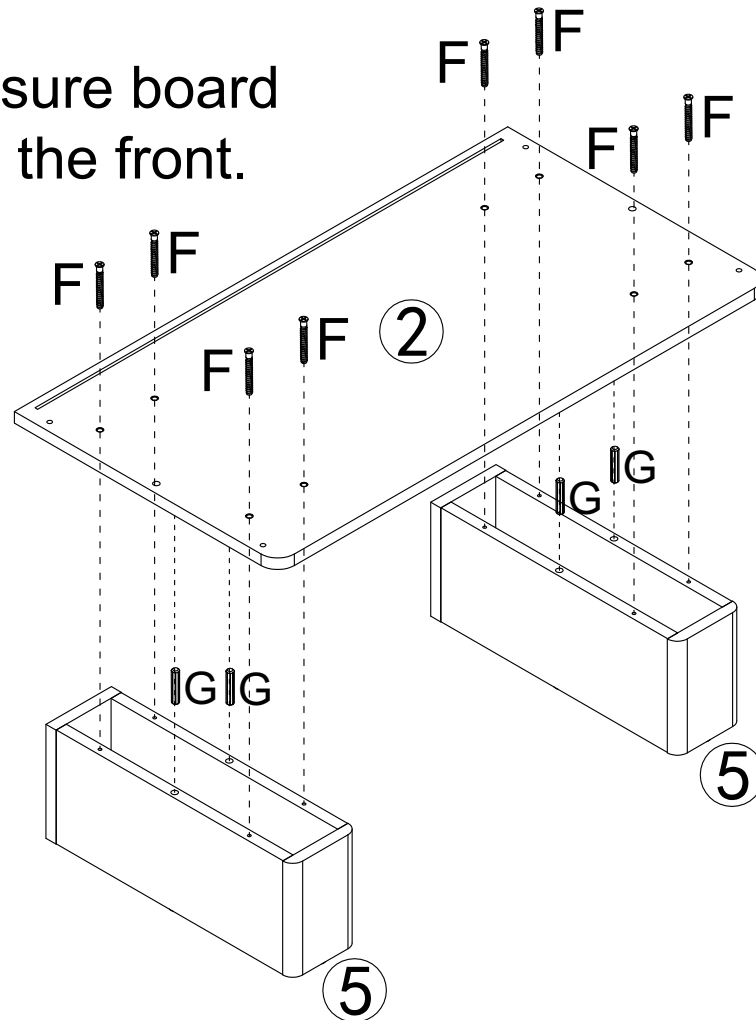
Please make sure board #5 towards to the front.





G	X4
	

F	X8
	
M5x40mm	

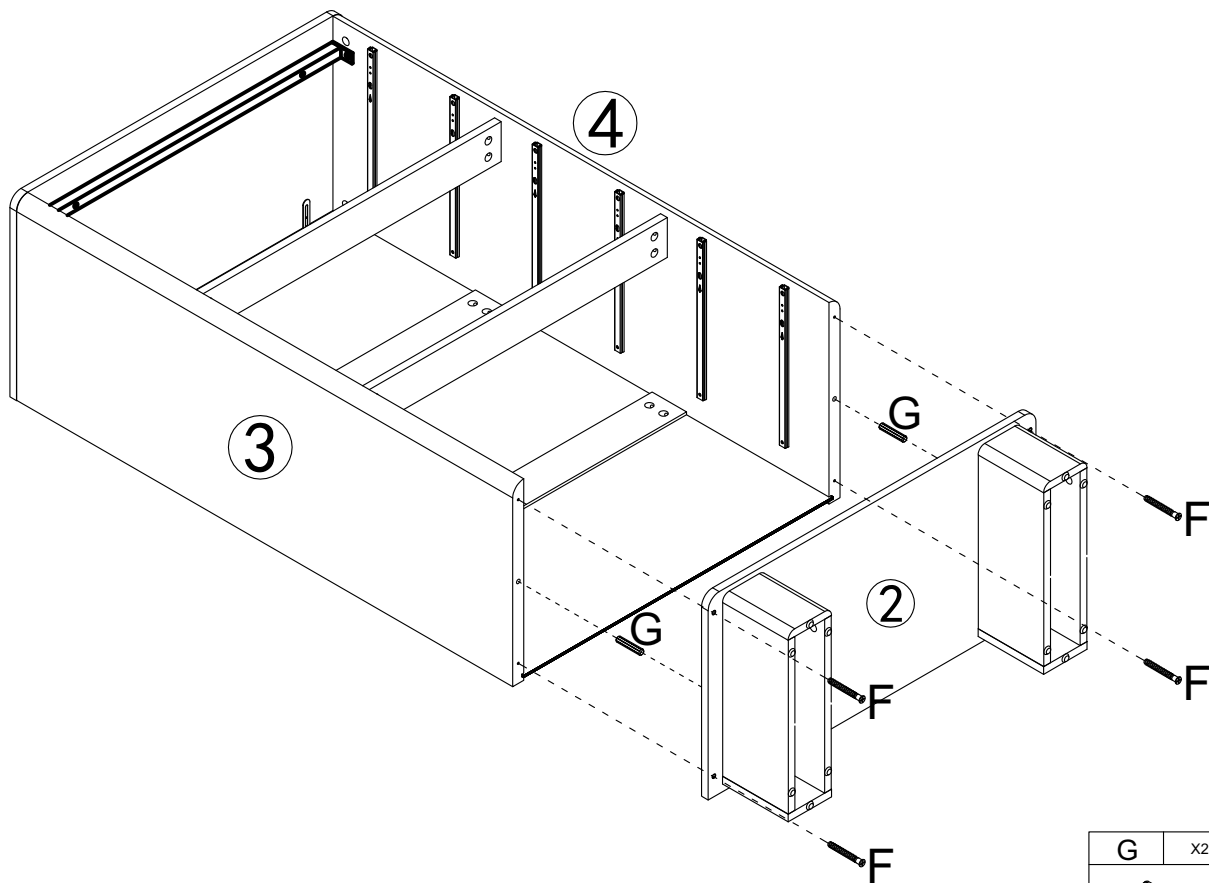
STEP 16



G	X2
	

F	X4
	
M5x40mm	

STEP 17

Attention:
Please secure the plastic
buckles to side boards ③ and ④.

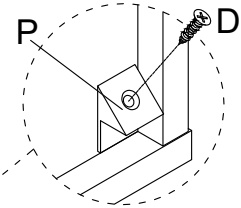
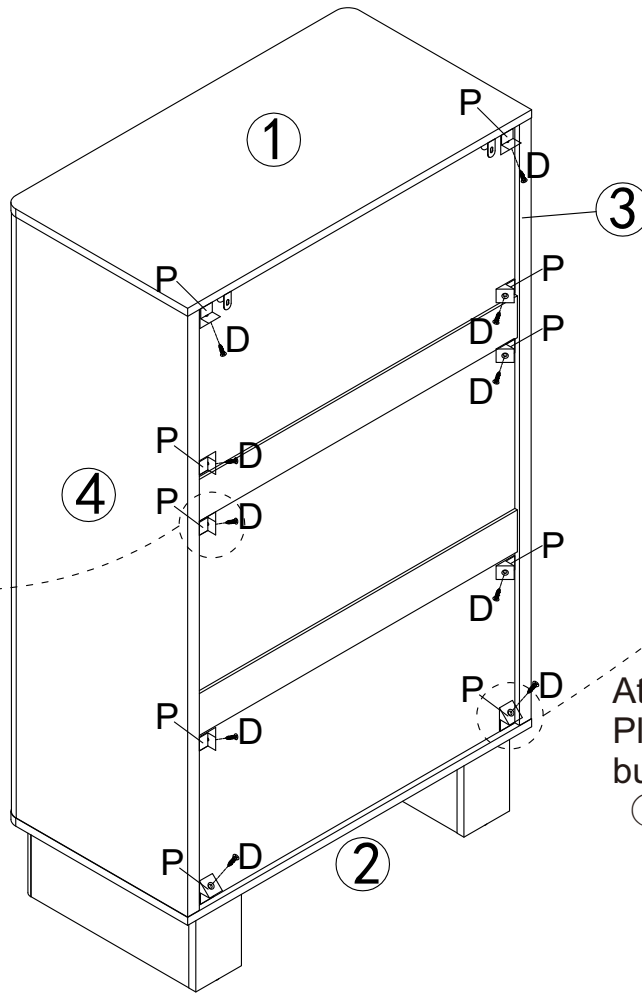
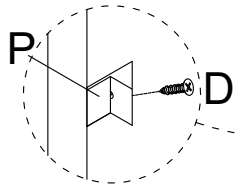

Attention:
Please secure the plastic
buckles to the top board
① and the bottom board ②.

P	X12	D	X12
		Black color	
		M3x16mm	

STEP 18

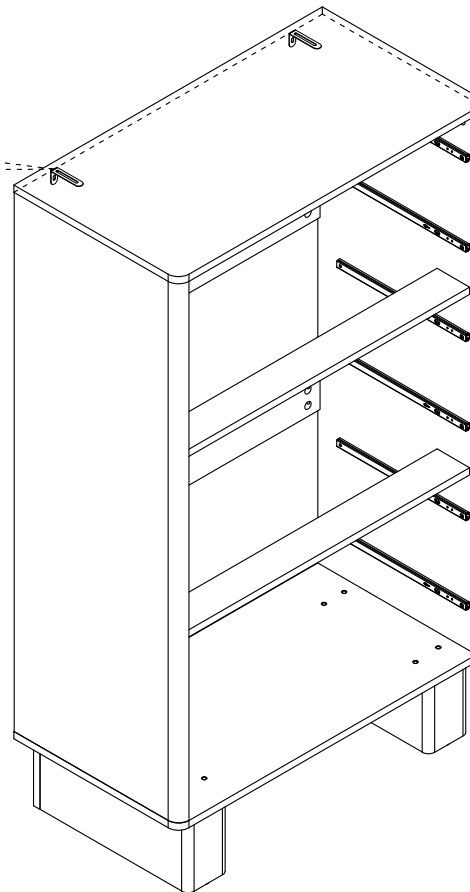
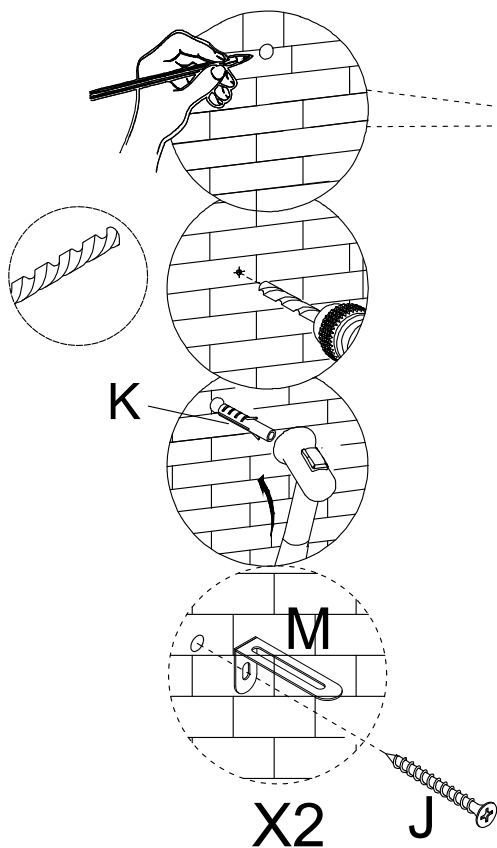

K	X2	J	X2
		M4x35mm	

STEP 19

Assembly Instruction of (Cabinet Drawer)

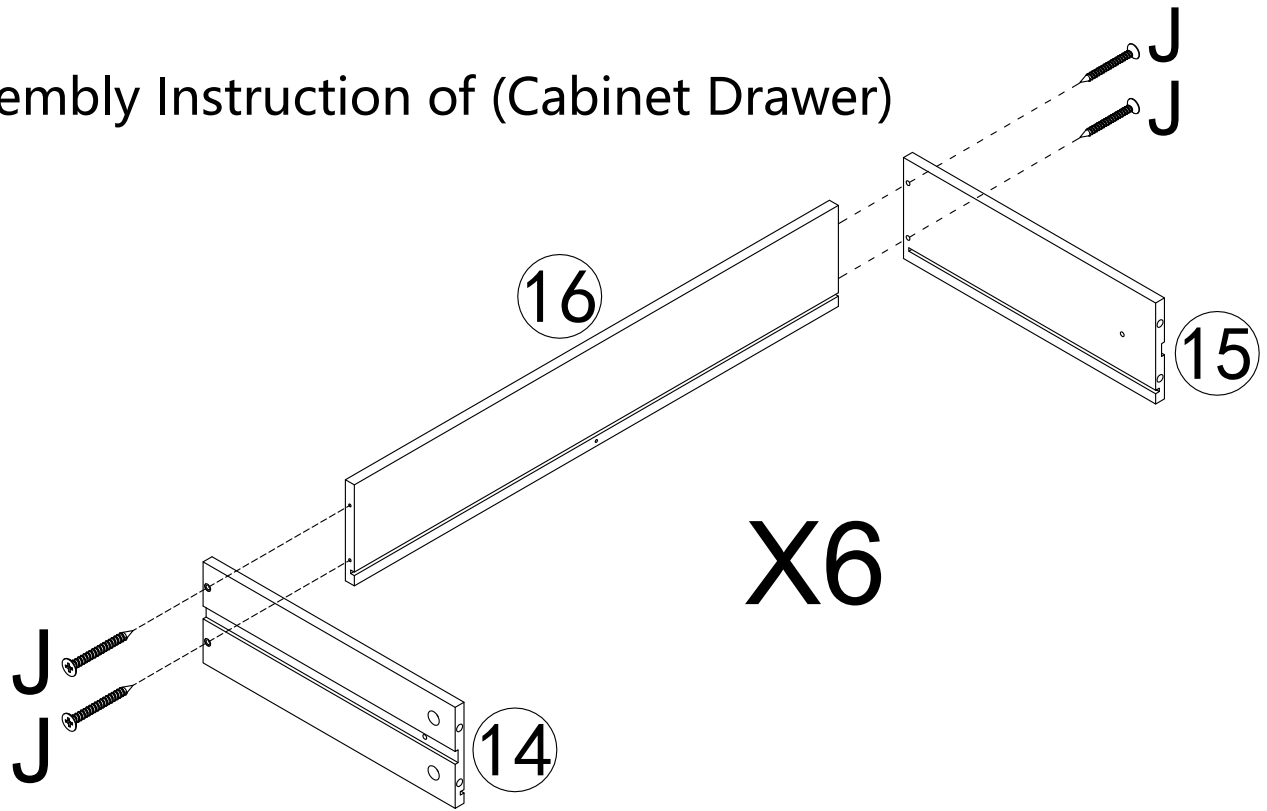

J	X24
	
M4x35mm	

STEP 20

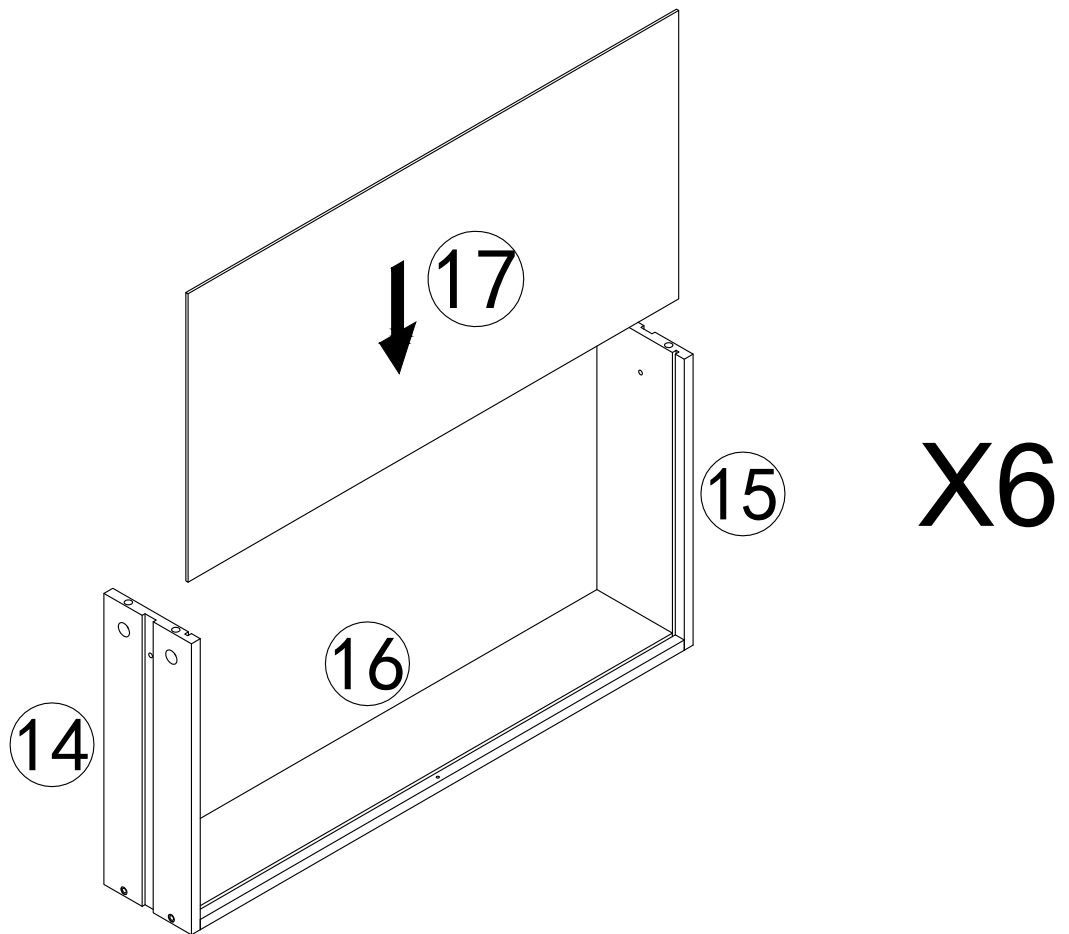

STEP 21

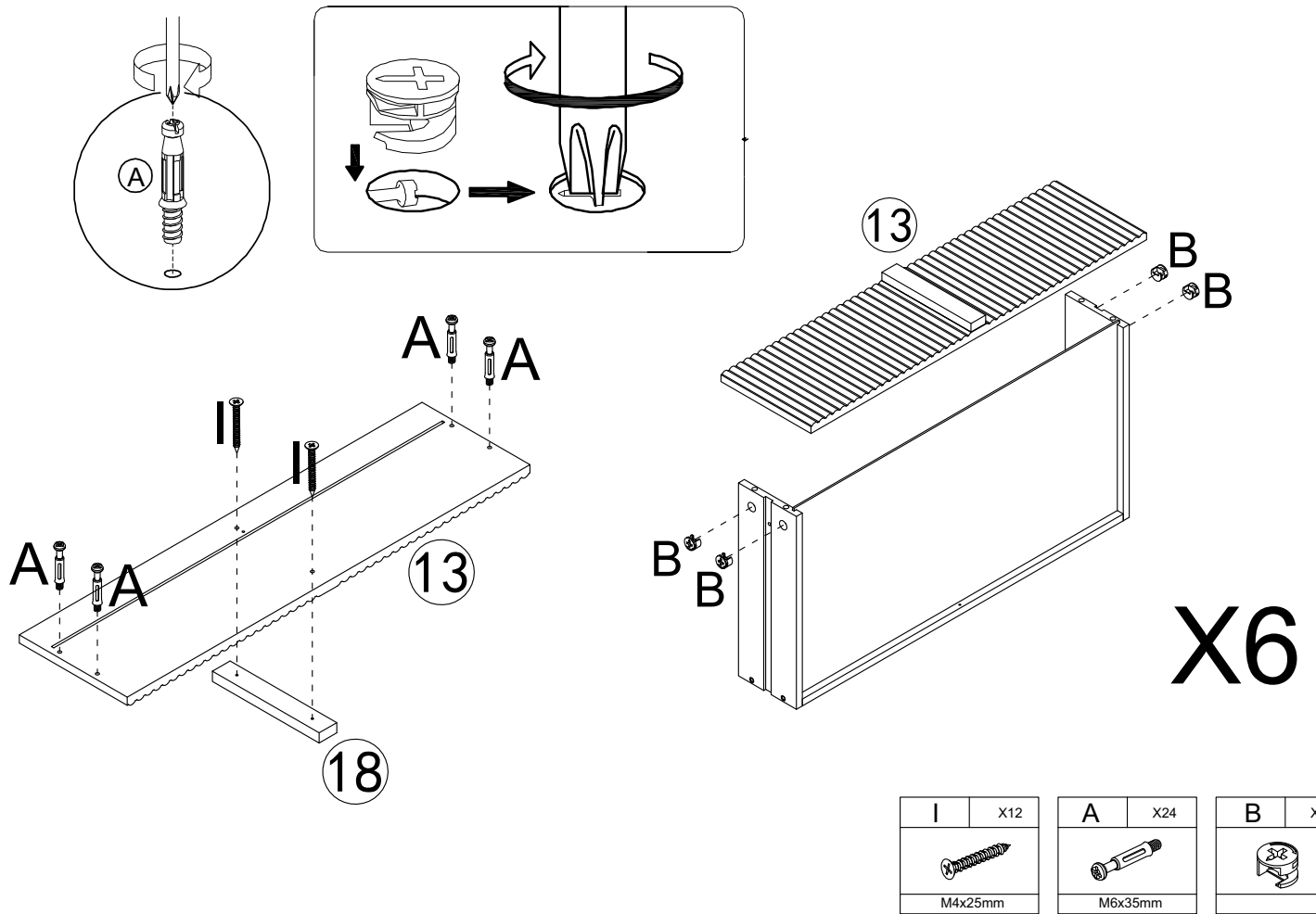

STEP 22

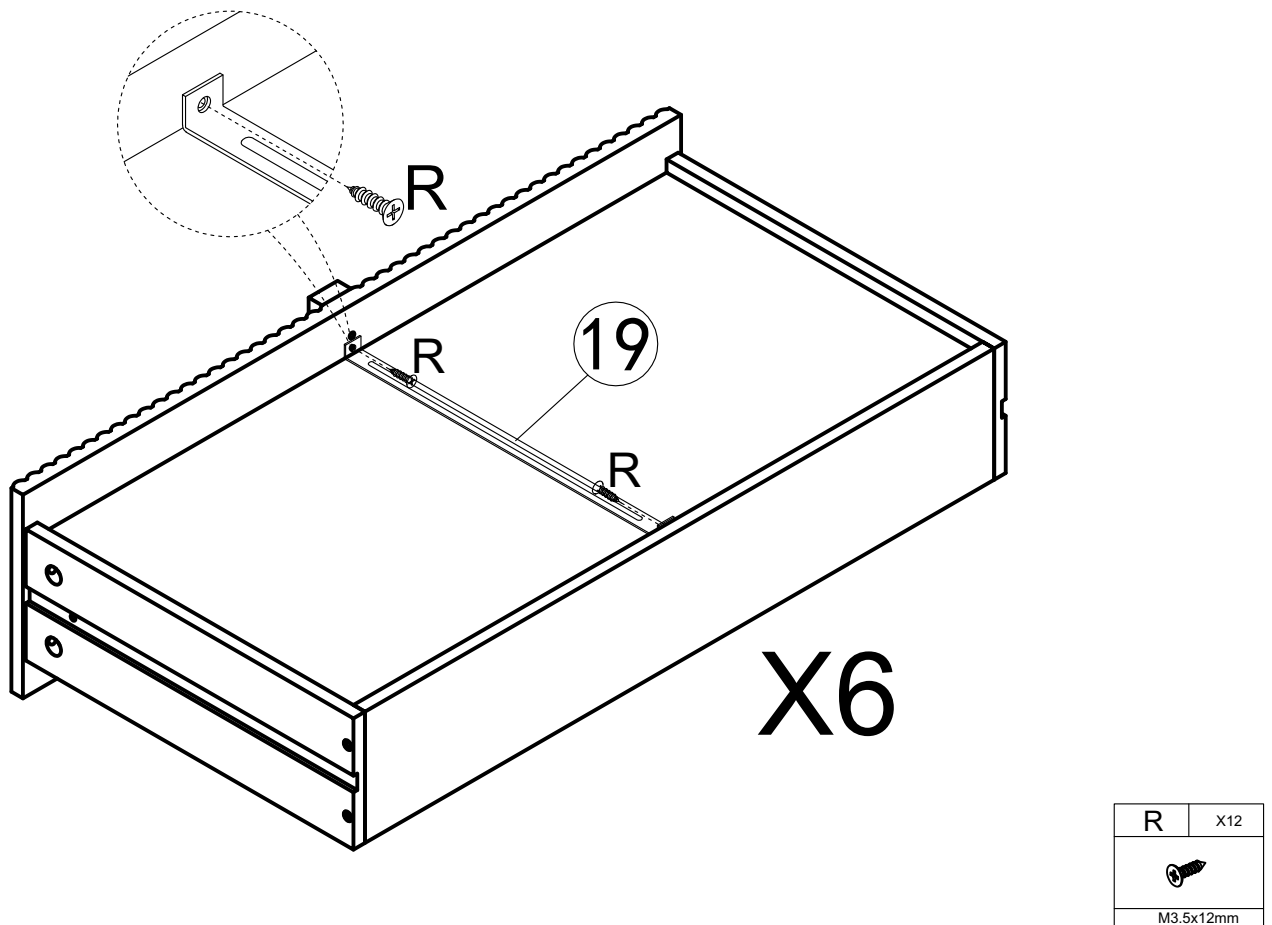

STEP 23

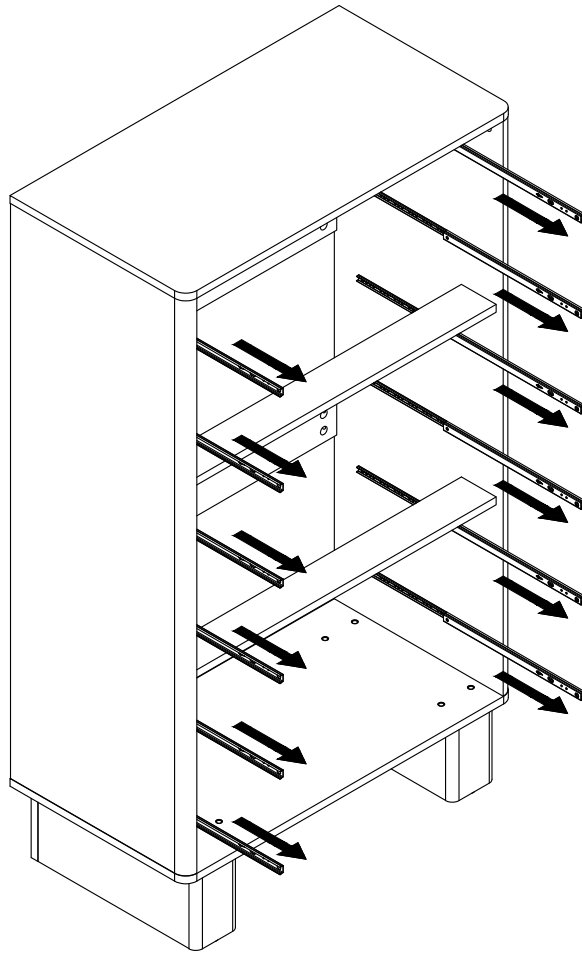

STEP 24

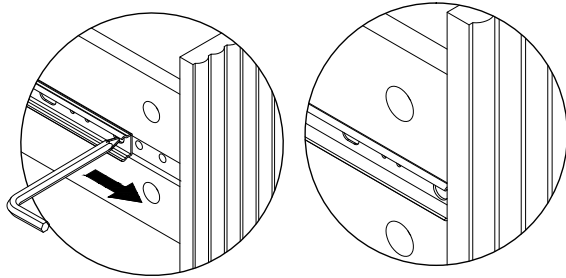

If the slide is tight, insert a screw driver into the hole and pull it out until it stops.

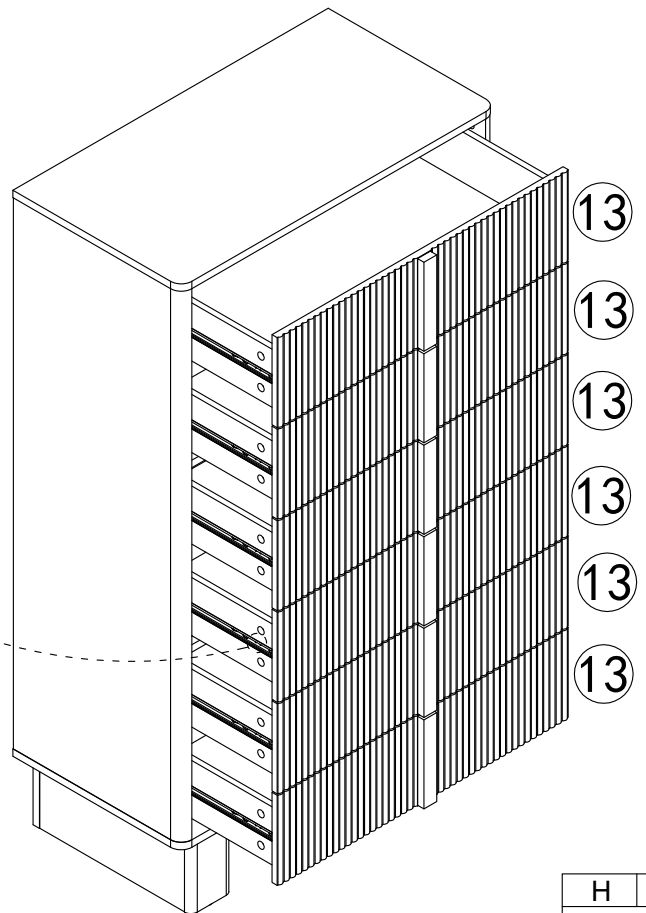
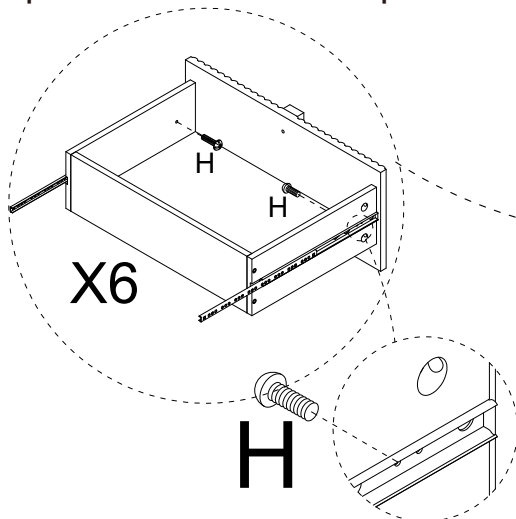

H	X12
	
M4x10mm	

Finished!

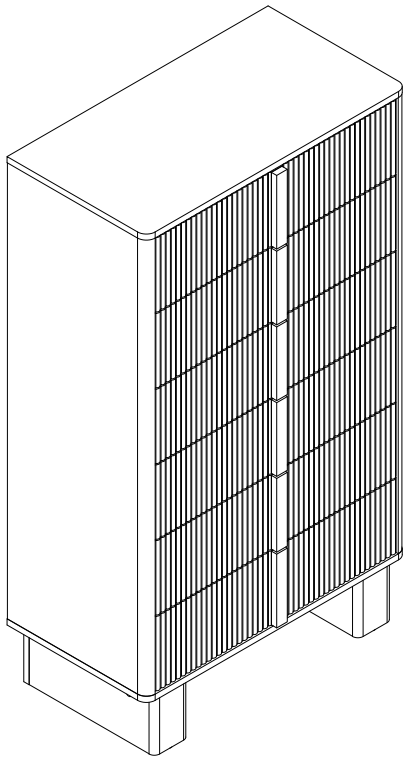

Congratulations, you have made it through the assembly process! We're almost there! ☆

Please perform following checks to ensure assembly is properly done.

- If drawer is misaligned, please check and ensure the screw position is correct as per step 3 & 4.

Move your product carefully, with 2 people lifting it to the preferred location. Clean the product with a dry cloth. You are all set!

Enjoy your fresh and updated living space thanks to the addition of your new product!