

NOTICE

- * Please make sure that you have all parts indicated before you begin assembly of this item. Refer to part list and hardware list below for guidance.
- * This item should be assembled on a soft surface to prevent scratching the finish during assembly
- * This item may require periodic tightening
- * This item may require a pair of pliers to unscrew the screws to a suitable length during assembly when feet are too short to fit into the item.





PREPARATION

- *Before beginning assembly of product, make sure all parts are present. Compare parts with package contents list and hardware contents list.
- *If any part is missing or damaged, do not attempt to assemble the product.
- *Estimated Assembly Time: 5 minutes.

CARE AND MAINTENANCE

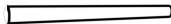
Always use felt pads under all articles to prevent discoloration or softening of the lacquer. Plastic and rubber bases on items can discolor wood. Wipe up spills immediately and avoid common hazards such as hot dishes, harsh solvents and abrasives. Cleaning should be done with a soft lint free cotton cloth dampened with water or furniture polish. On highly used surfaces we recommend applying a quality paste wax which should be used on a regular basis to provide additional protection from scratches and spills. How often you apply the wax depends on how much wear the furniture receives.

Part List and Hardware List

| PIECE | DESCRIPTION | PICTURE | QUANTITY |
|-------|------------------------|---|----------|
| A | Table Top |  | 1X |
| B | Leg |  | 4X |
| HW1 | Allen Key Driver |  | 1X |
| HW2 | Allen Bolt 8x1.41x50mm |  | 8X |
| HW3 | Flat Washer |  | 8X |

Owner Manual

Product Dimensions: 19.7"W x 15.7"D x 22"H

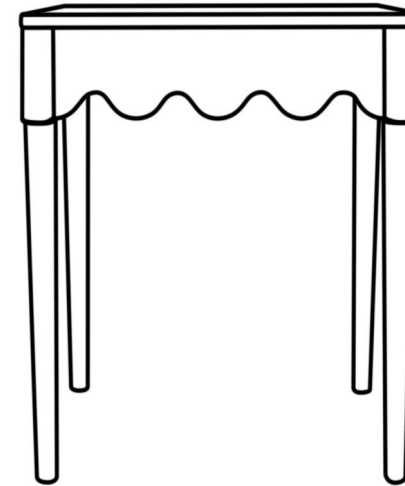

 WARNING 

Weight Capacity: 40LBS

Warning: Do not stand on the desk

Warning: Do not over torque bolts.

PREPARATION

*Before beginning assembly of product, make sure all parts are present. Compare parts with package contents list and hardware contents list.

*If any part is missing or damaged, do not attempt to assemble the product.

*Estimated Assembly Time: 5 minutes.

*If you are having difficulty, our friendly Customer Care team is always here to help.

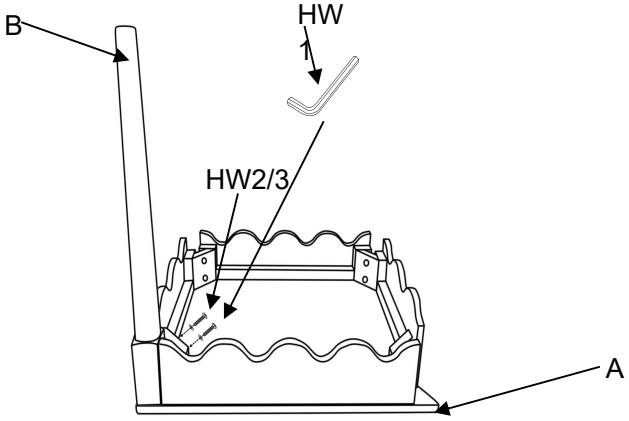
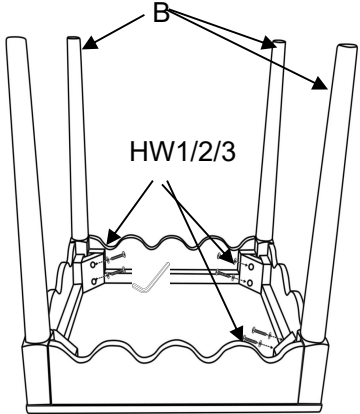
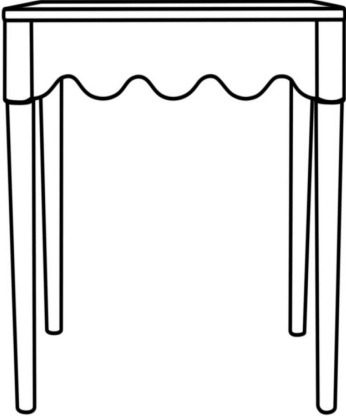
| | | |
|--|--|---|
|  |  |  |
| <p>Step 1: Take all packaging off the table. Screw leg B to table top A. 2pcs screws & flat washers HW2/3 required. Allen key driver required.</p> | <p>Step 2: Screw the rest legs B to table top. 6pc screw & flat washers HW1/2/3 required. Allen key driver required.</p> | <p>Step 3: Turn the table up to the right side. Assembling process done.</p> |