

ASSEMBLY INSTRUCTIONS DINING TABLE ITEM

ASSEMBLY REQUIREMENTS

2-PERSON
ASSEMBLY

ASSEMBLY TIME
(Approximate)

30 MINUTES

Thank you for purchasing our product!

Please refer and use this assembly instruction to assemble the product.

Contact our customer service department in case there are any missing or damage parts or hardware. Replacement parts are normally shipped within 2 or 3 days



PRODUCTS PURCHASED THROUGH OUR AUTHORIZED VENDORS ONLY ARE ELIGIBLE FOR REPLACEMENT PARTS

We appreciate your business!

**THIS PRODUCT IS FOR INDOOR AND HOUSEHOLD USE ONLY -
NOT FOR COMMERCIAL USE.**

ASSEMBLY PREPARATION

1. Remove all packaging materials, staples and packing straps from the carton.
2. Refer to Parts List and Hardware List, and ensure they are complete before you start assembling.
3. Place all wooden parts on a clean, flat and soft surface(e.g. carpet or rug) to prevent parts from getting scratched.

SAFETY PRECAUTION

1. KEEP ALL HARDWARE PARTS OUT OF REACH OF CHILDREN.
2. DISPOSE PLASTIC PACKAGING MATERIAL IMMEDIATELY TO AVOID ANY RISK OF SUFFOCATION TO CHILDREN AND ANIMALS.

TIPS FOR ASSEMBLY

1. Allow ample room for assembly and close proximity to where product will be placed.
2. Assemble the product on a surface that does not scratch or damage the exterior gloss and finish of the furniture.
3. Please check all of the parts and quantities are included before assembly. Contact customer service for missing parts.
3. Identify all of the parts, hardware and quantities required for each step.
4. During assembly, do not over-tighten any fittings as this may cause damage.
5. DO NOT USE POWER TOOLS TO ASSEMBLE THIS PRODUCT.
6. Always place the product on a flat surface.
7. Do not sit or stand on the partially assembled product; only use the product for which it is intended.

CARE AND MAINTENANCE





- Wipe clean with a soft, dry cloth; avoid the use of harsh chemicals or household cleaners as they may damage the exterior finish of the furniture.
- Hardware may loosen over time. Periodically, check that all connections are tight; re-tighten as necessary.
- Solid wood is impacted by heat and humidity fluctuations which may cause small joint separations or hairline cracks; place the furniture away from direct sunlight and air conditioning vents, heating vents or units to protect the furniture.

ASSEMBLY INSTRUCTIONS DINING TABLE

PARTS LIST (FOR 1 NOS. OF TABLE)

| NO. | COMPONENT | QTY. |
|-----|----------------|------|
| P1 | TABLE TOP | 1 |
| P2 | PEDESTAL LEG | 1 |
| P3 | LEG BASE BOARD | 1 |
| P4 | FOOT BLOCK | 4 |
| P5 | MOUNTING BAR | 2 |

HARDWARE LIST (FOR 1 NOS. OF TABLE)

| NO. | DESCRIPTION | QTY. | EXTRA* |
|-----|--|------|--------|
| H1 | ALLEN KEY  | 1 | |
| H2 | JCBC BOLT M6 X 40MM  | 20 | 1 |
| H3 | SPRING WASHER  | 20 | 2 |
| H4 | ADJUSTABLE LEG GLIDE  | 4 | 2 |

* Extra Hardware For Spare Use

Step 1. First, place Leg Base Board (P3) bottom-side up. Next, align holes on Foot Block (P4) to holes on Leg Base Board (P3). Then insert JCBC Screw (H2) fitted with Spring Washer (H3) into each of the 2 holes. Use Allen Key (H1) to tighten (H2). Do not tighten (H2) completely until both screws are in place. Do not over tighten the screws.

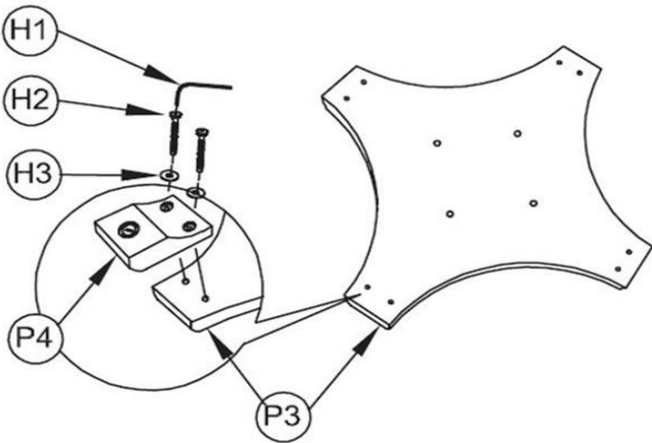

Step 2. Place Pedestal Leg (P2) bottom-side up. Align the 4 holes at the central part of Leg Base Board (P3) to holes on Pedestal Leg (P2). Then insert JCBC Screw (H2) fitted with Spring Washer (H3) into the holes. Use Allen Key (H1) to tighten (H2). Do not tighten (H2) completely until all 4 screws are in place. Do not over tighten the screws.

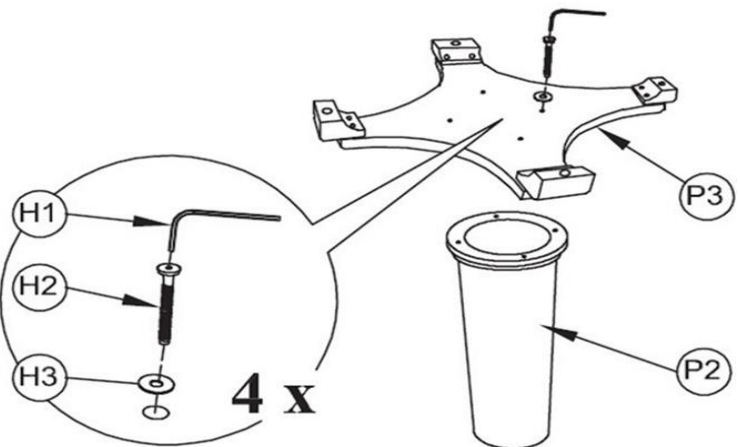

Step 3. Place Pedestal Leg (P2) standing up as shown. Align the 4 innermost holes on Mounting Bar (P5) to the 4 holes on Pedestal Leg (P2). Then insert JCBC Screw (H2) fitted with Spring Washer (H3) into the holes. Use Allen Key (H1) to tighten (H2). Do not tighten (H2) completely until all 4 screws are in place. Do not over tighten the screws.

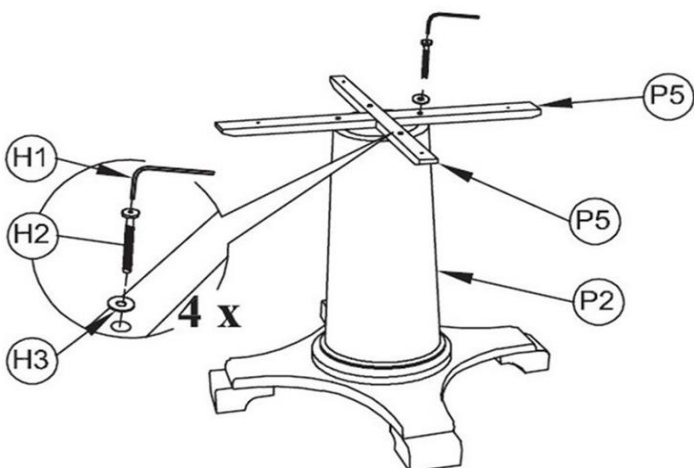

Step 4. Place Table Top (P1) bottom-side up on a material that does not scratch or damage the part. Align holes on Mounting Bar (P5) to holes on table bottom. Insert JCBC Screw (H2) fitted with Spring Washer (H3) into the holes. Use Allen Key (H1) to tighten (H2). Do not tighten (H2) completely until all 4 screws are in place. Do not over tighten the screws. Insert Adjustable Leg Glide (H4) to the Foot Block holes, and use hand to screw in (H4) completely. Do not over tighten. Turn the table right-side up. The assembly of the table is complete.

