



## Vestil Manufacturing Company

*A company dedicated to solving loading dock and material handling problems since 1955.*

2999 North Wayne Street, P.O. Box 507, Angola, IN 46703

Telephone: (260) 665-7586 -or- Toll Free: (800) 348-0868

Fax: (260) 665-1339

<http://www.vestil.com/> email: [info@vestil.com](mailto:info@vestil.com)

### EHLT-Series Electric Hydraulic Scissors Lift Table Instruction Manual



Model EHLT

#### About the EHLT Electric Hydraulic Scissors Lift Table:

The EHLT-series Lift Table is designed to lift and lower uniform loads in indoor environments. It is intended for a permanent installation on a level concrete surface.

#### Receiving instructions:

After delivery, remove the packaging from the product. Inspect the product to determine whether it sustained damage during transport. If damage is discovered, record a complete description of it on the bill of lading and file a claim with the carrier immediately! If the product is undamaged, discard the packaging.

#### NOTE:

The end user is solely responsible for confirming that product design, use, and maintenance comply with laws, regulations, codes, and mandatory standards applied where the product is used.

#### Replacement Parts and Technical Assistance:

If you have questions that are not addressed in these instructions, or to order replacement parts, labels, and accessories, call (260) 665-7586 and ask for the Service and Parts Department. You can also reach Service and Parts online at [http://www.vestilmfg.com/parts\\_info.htm](http://www.vestilmfg.com/parts_info.htm).

#### Electronic Copies of Instruction Manuals:

Additional copies of this instruction manual may be downloaded from <https://www.vestil.com/page-manuals.php>.

## Table of Contents

Signal Words ... ..	<a href="#">2</a>
Hazards ... ..	<a href="#">2</a>
Model Number and Capacity ... ..	<a href="#">4</a>
Exploded Part Views and Bills of Material ... ..	<a href="#">5</a>
Electrical and Hydraulic System Diagrams ... ..	<a href="#">9</a>
Internal Power Unit ... ..	<a href="#">13</a>
External Power Unit ... ..	<a href="#">14</a>
Installation Instructions ... ..	<a href="#">15</a>
Record of Satisfactory Condition ... ..	<a href="#">18</a>
Operation Instructions ... ..	<a href="#">18</a>
Inspection and Maintenance ... ..	<a href="#">21</a>
Troubleshooting ... ..	<a href="#">24</a>
Labeling Diagram ... ..	<a href="#">25</a>
Appendix: Bills of Material for High-Capacity Tables ... ..	<a href="#">26</a>
6-1/2 HP External Power Unit Assembly ... ..	<a href="#">30</a>
Limited warranty ... ..	<a href="#">27</a>

## SIGNAL WORDS

This manual uses SIGNAL WORDS to direct the reader's attention to important safety-related messages. These messages describe uses of the product that could result in personal injury or property damage. Each signal word corresponds to a specific hazard level. The following are definitions of signal words that might appear in this manual.



Identifies a hazardous situation which, if not avoided, WILL result in DEATH or SERIOUS INJURY. Use of this signal word is limited to the most extreme situations.



Identifies a hazardous situation which, if not avoided, COULD result in DEATH or SERIOUS INJURY.



Indicates a hazardous situation which, if not avoided, COULD result in MINOR or MODERATE injury.



Identifies practices likely to result in product/property damage, such as operation that might damage the product.

## HAZARDS

Vestil Manufacturing strives to identify all foreseeable hazards associated with the use of its products. However, material handling is dangerous and no manual can address every risk. The end user is ultimately responsible for exercising sound judgment at all times in the use of this product.



Improper or careless operation of this device might result in serious personal injuries.

- ***It is the User's responsibility to read and understand this entire manual before installing, assembling, using or servicing this lift table.*** Keep this manual in a location known to persons who use the lift table. Read the manual whenever necessary to refresh your understanding of proper use, inspection, and maintenance procedures. ***Failure to read and understand this owner's manual before using or servicing the lift table constitutes a misuse of the product.***
- The Electric Hydraulic Scissors Lift Table presents pinch point and hydraulic pressure hazards to the user and bystanders. ALWAYS follow these instructions to avoid injury.

- The lift table is intended for use on a level concrete surface. DO NOT use a lift table that has not been anchored to a level concrete surface. See installation instructions starting on page [14](#).
- The lift table shall be installed only by trained and qualified personnel with access to appropriate equipment. Electrical connections shall be performed by a qualified electrician.
- DO NOT allow untrained or unauthorized persons to operate the lift table. DO NOT allow untrained or unauthorized persons to remain near a lift table while it is in use.
- DO NOT load the table beyond its lift rated capacity. Handle only stable and safely arranged loads within the maximum capacity of the lift. The lift capacity can be found on the nameplate on the hinged end of the platform.
- ALWAYS use care to center and distribute the load evenly on the lift platform.
- DO NOT attempt to lift an overhanging or cantilever load.
- ALWAYS check for overhead clearance with obstructions and energized electrical components before lifting a load.
- DO watch the load when the lift table is in operation.
- ALWAYS keep clear of the lift table while it is moving. ALWAYS keep the surrounding area clear of personnel and equipment when the lift table is in motion.
- DO NOT place hands or feet under the platform. DO NOT put any body part in the scissor mechanism.
- DO NOT use this lift table to raise personnel, unless it is fitted with safety devices such as handrails, gates, and/or snap chains, as provided by or approved by the manufacturer.
- DO NOT store objects under the platform.
- DO NOT use the lift table if any damage is observed, or unusual noises heard.
- DO NOT operate a lift table with its perimeter toe guard removed, disabled, or inoperable. An optional accordion skirt may be installed in above-ground installations.
- DO ensure that all information, safety, and warning labels remain in place and are legible.
- DO remove any load from the lift table before servicing the lift table or its hydraulic power unit. DO completely lower the platform, or use the attached maintenance prop bars to support the platform, before servicing this product. DO depressurize the hydraulic system before service. See the inspection instructions on page [19](#).
- If oil is needed, DO use an anti-wear hydraulic oil with a viscosity grade of 150 SUS at 100°F (ISO 32 cSt @ 40°C) or Dexron non-synthetic transmission fluid. DO NOT use brake fluid or jack oils in the hydraulic system.
- Contact the manufacturer for SDS (Safety Data Sheet) information.
- Maintenance and repairs are to be done only by personnel qualified to perform the required work. Consideration will not be given for warranty repair charges without prior written authorization by the manufacturer.
- DO NOT perform any modifications to the lift table without the manufacturer's written approval. Failure to receive authorization for changes to the equipment automatically voids the warranty.

**NOTICE**

Proper use and maintenance are essential for this product to function properly.

- Always use this product in accordance with the instructions in this manual.
- Periodically lubricate pivot points with bearing grease.
- Keep the product dry and clean at all times. Always use this product indoors.
- Use only factory-approved replacement parts. Contact Vestil Manufacturing to order replacement or spare parts.
- Contact the manufacturer for SDS information.

## **MODEL NUMBER AND CAPACITY**

The lift table model number, serial number and capacities are printed on the nameplate, found on the hinged side of the platform. Refer to the product catalog of the factory for further information. Include the model and serial numbers in all correspondence with your dealer or the factory.

The load capacity rating as printed on the nameplate of your lift table designates its net capacity. The addition of ancillary equipment to the lift table will necessitate a lowering of the load capacity. The lift table's load capacity must never be exceeded, as permanent damage or personal injury may result.

EHLT model number coding:

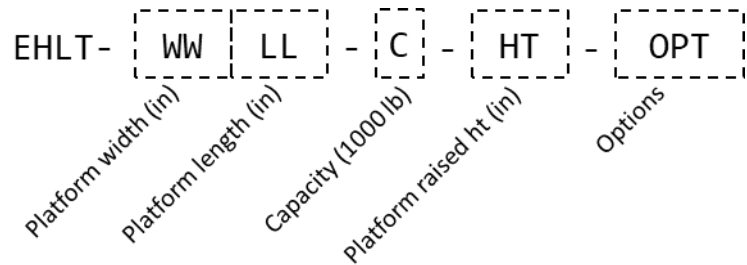

This space intentionally blank.

**EXPLODED PART VIEWS AND BILLS OF MATERIAL**

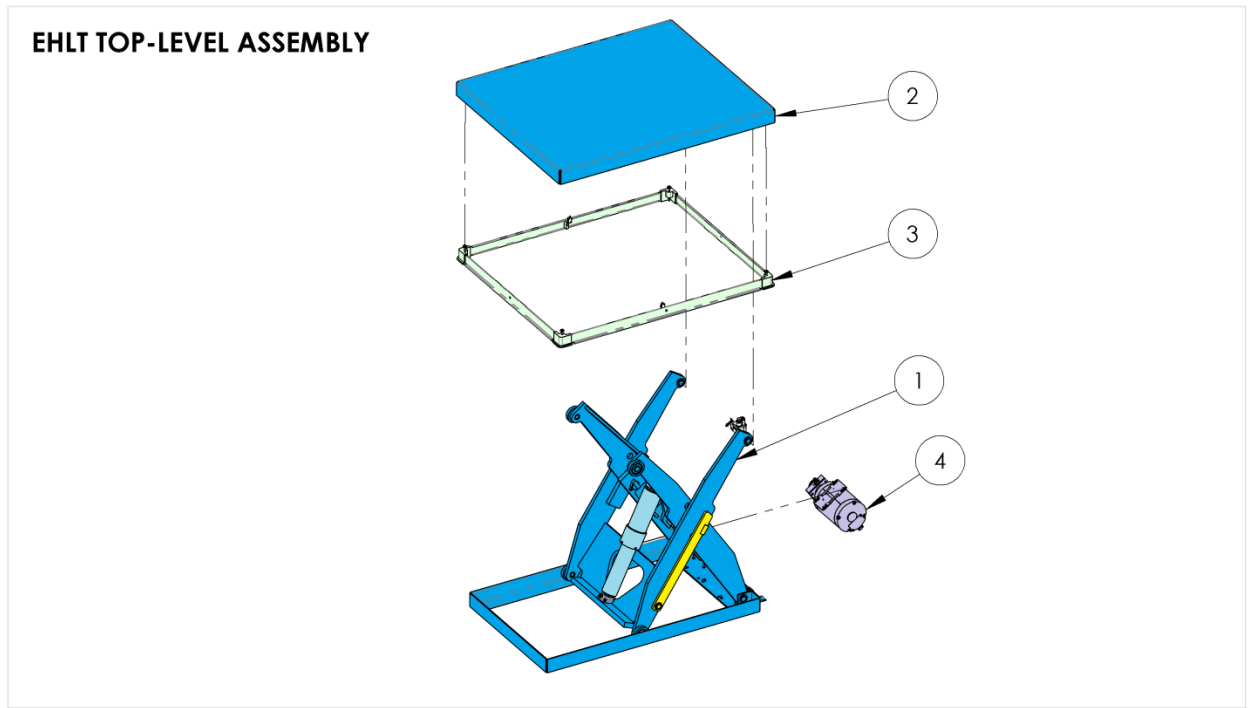

**EHLT Top-Level Bill of Materials**

ITEM	DESCRIPTION
1	BASE ASSEMBLY
2	PLATFORM
3	PERIMETER TOE GUARD ASSEMBLY
4	POWER UNIT ASSEMBLY (INTERNAL UNIT SHOWN)

*\* See separate illustrations and tables for detailed parts lists.*

Base Assembly Exploded View (43" base depicted)

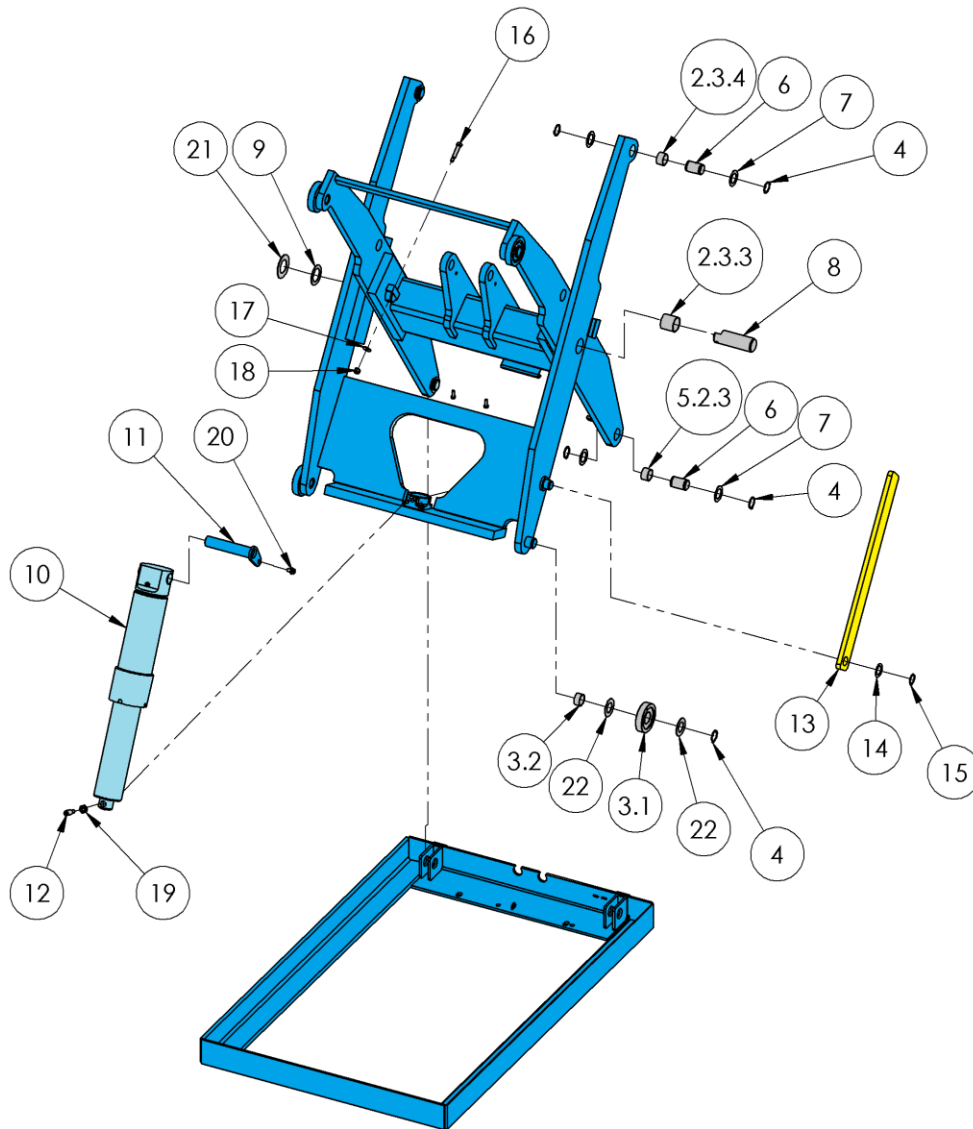

## Base Assembly Bill of Materials

ITEM	PART NUMBER	DESCRIPTION	QTY
2.3.3	01-111-003	BUSHING, POLYGON 1 1/2 ID X 1 1/2 LG	2
2.3.4	01-111-002	BUSHING, POLYGON 1 1/8 ID X 3/4 LG	2
3	01-527-001	ROLLER W/ BUSHING	4
3.1	01-027-001	ROLLER, Ø3 1/4 x 3/4 W	1
3.2	01-111-001	BUSHING, POLYGON 1 1/8 ID x 5/8 LG	1
4	68021	EXTERNAL RETAINING RING, PHOSPHATE FINISH, 1-1/8"	12
5.2.3	01-111-002	BUSHING, POLYGON 1 1/8 ID X 3/4 LG	2
6	01-112-004	PIN, CLEVIS	4
7	33454	NARROW MACHINERY BUSHING, PLAIN FINISH, 1 3/4" X 18 GA	8
8	01-112-019	PIN, SCISSOR PIVOT, Ø 1 1/2"	2
9	33474	SPACER, SHIM, 1 1/2" ID X 2 1/4 OD X 18 GA	2
10	99-021-906-001	CYLINDER, HYDRAULIC, Ø 2 1/2" x 10"	1 or 2
	99-021-901-001	CYLINDER, HYDRAULIC, Ø 3" x 10"	
11	01-112-001 *	PIN, CLEVIS, CYLINDER (NOT DEPICTED IN EXPLODED VIEW)	1
	24-112-002 *	PIN, CYLINDER PIVOT (NOT DEPICTED IN EXPLODED VIEW)	2
	24-612-003 *	WELDMENT, CYLINDER PIN	1 or 2
12	01-118-001	BOLT, CYLINDER RETAINING	1 or 2
13	24-037-001	MAINT PROP, EHLT	2
14	33444	MACHINE BUSHING, Ø 1 X 18 GA.	2
15	20-117-003	EXTERNAL RETAINING RING, 1" DIA SHAFT	2
16	26333	SHOULDER SCREW 0.375x1.5" LG	2
17	33006	FLAT WASHER, ZINC PLATED, USS, Ø5/16"	2
18	37021	NYLON INSERT LOCK NUT, GRADE 2, ZINC FINISH, 5/16"-18	2
19	36209	1/2 - 13 HEX JAM NUT PLAIN	1
20	32415 *	Ø5/16 - 18 x 1/2 HWH THREAD CUTTING SCREW, TYPE F, ZINC	1 or 2
	64134 *	SPRING PIN 3/16 X 1 1/8 (NOT DEPICTED IN EXPLODED VIEW)	1
21	01-115-002	WASHER, THRUST BEARING	2
22	01-115-001	WASHER, THRUST BEARING, 1 1/8" ID	8

\* Cylinder mounting hardware varies by cylinder count and base width. Contact the factory for details regarding your specific Table.

## Toe Guard Assembly Exploded View

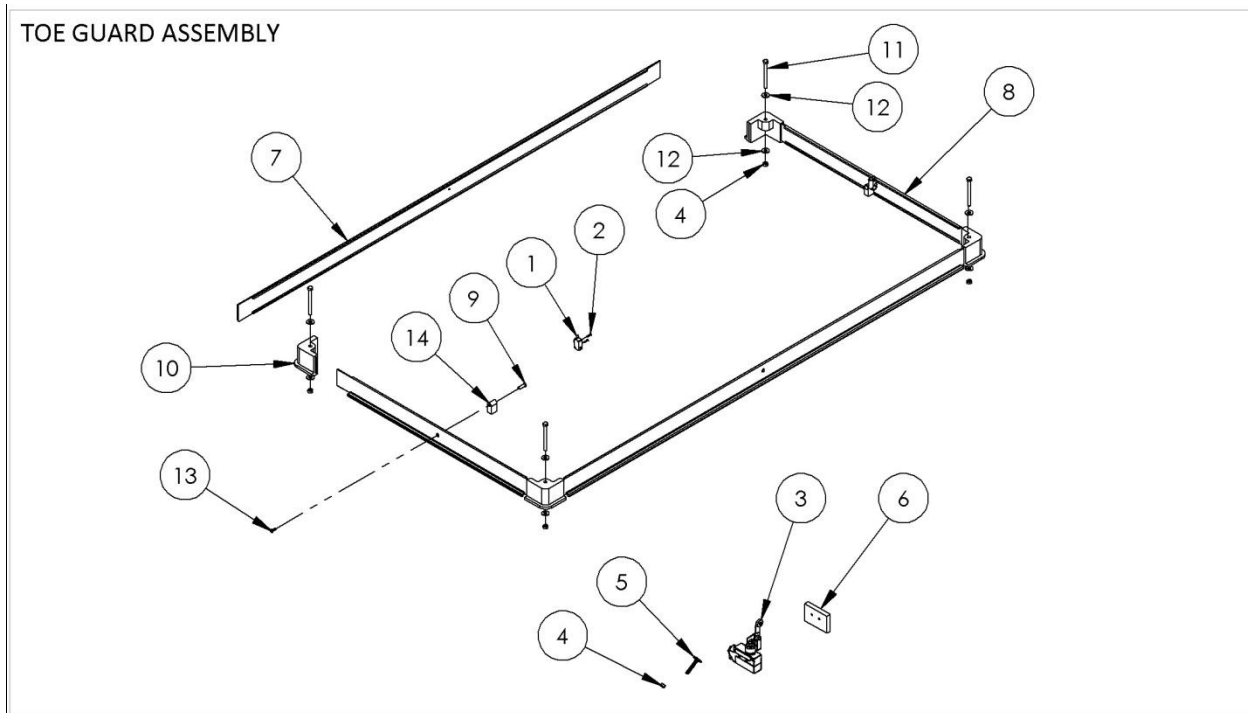

## EHLT Perimeter Toe Guard Assembly and Upper Travel Limit Switch Bill of Materials

ITEM	PART NUMBER	DESCRIPTION	QTY.
1*	01-022-022	SWITCH, LIMIT (N. C. MICRO)	2
2*	24008	4-40 X 1/2 BHCS	4
3†	01-022-001	LIMIT SWITCH W/ROLLER ARM	1
4†	37018	NYLON LOCK NUT, GRADE 2, ZINC FINISH, 1/4"-20	5
5†	22805	ELEVATOR BOLT, LIMIT SWITCH	1
6†	24-016-002	BRACKET, EHLT SWITCH MOUNT	1
7 & 8	01-015-016 01-015-014 01-015-020 01-015-013 01-015-015 01-015-023	TOE GUARD EXTRUSION FOR 24" SIDES TOE GUARD EXTRUSION FOR 30" SIDES TOE GUARD EXTRUSION FOR 40" SIDES TOE GUARD EXTRUSION FOR 48" SIDES TOE GUARD EXTRUSION FOR 60" SIDES TOE GUARD EXTRUSION FOR 72" SIDES <i>CONSULT FACTORY FOR OTHER SIDE LENGTHS</i>	2 + 2
9	01-145-010	SPECIALTY HARDWARE, TOE GUARD	2
10	01-015-009	TOE GUARD SUPPORT, CAST RUBBER HOUSING	4
11	11015	HEX BOLT, GRADE A, ZINC PLATED, 1/4"-20 X 3"	4
12	33004	FLAT WASHER, USS, ZINC PLATED, Ø1/4"	8
13	24189	#8-32 FHSCS	2
14	01-015-017	TOE GUARD, LIMIT SWITCH ACTUATOR	2

\* Item attaches separately to platform.

† Item part of upper travel limit switch; attached to base.

**ELECTRICAL AND HYDRAULIC SYSTEM DIAGRAMS**

**WARNING** Care should be taken to identify all potential hazards and comply with applicable safety procedures before beginning work. Ensure that all system pressure and electrical power have been removed before attempting to work on the electrical or hydraulic systems. Follow all applicable lockout/tagout procedures.

**WARNING** The load must be removed, and the platform either positively and adequately supported or fully lowered, before any work is performed on the lift table.

Only qualified individuals trained to understand mechanical devices and their associated electrical and hydraulic circuits, as well as the hazards associated with them, should attempt troubleshooting and repair of this equipment.

**115 VAC, Single-Phase Electric Circuit Diagram (24124012 Rev. B)**

Note: Overcurrent & short circuit protection and disconnect must be provided by end user.

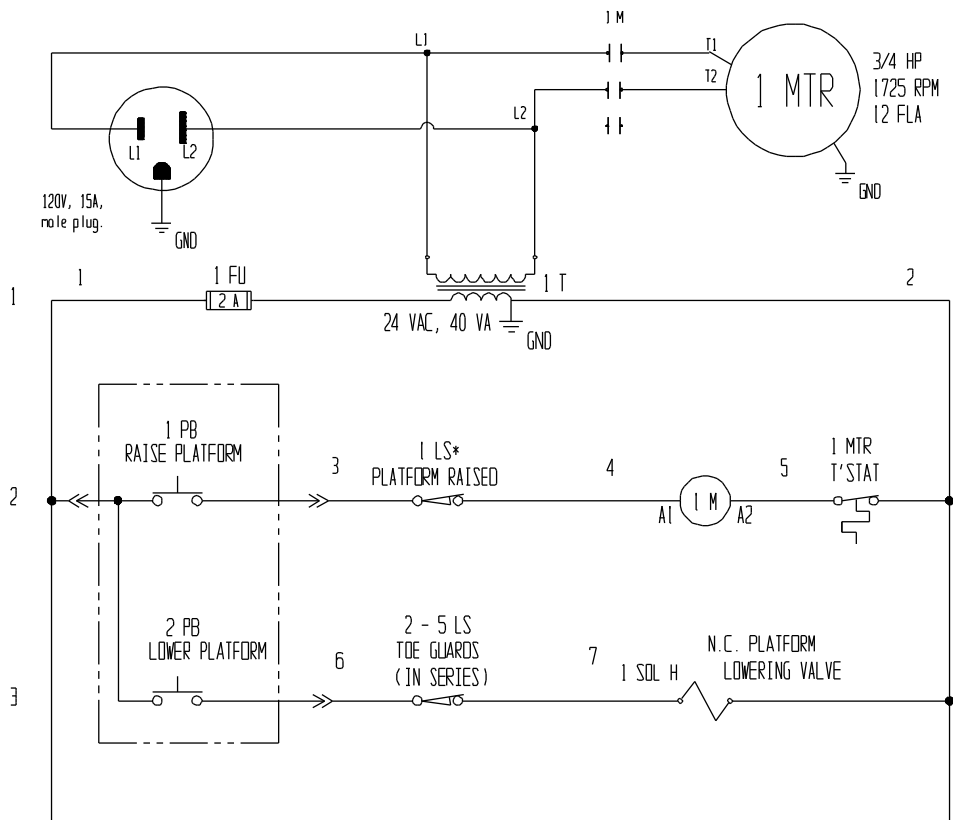

\* Number of toe guard switches can vary according to size.

### 208-230 VAC, Single-Phase Electric Circuit Diagram (24124013 Rev. B)

Note: Overcurrent & short circuit protection and disconnect must be provided by end user.

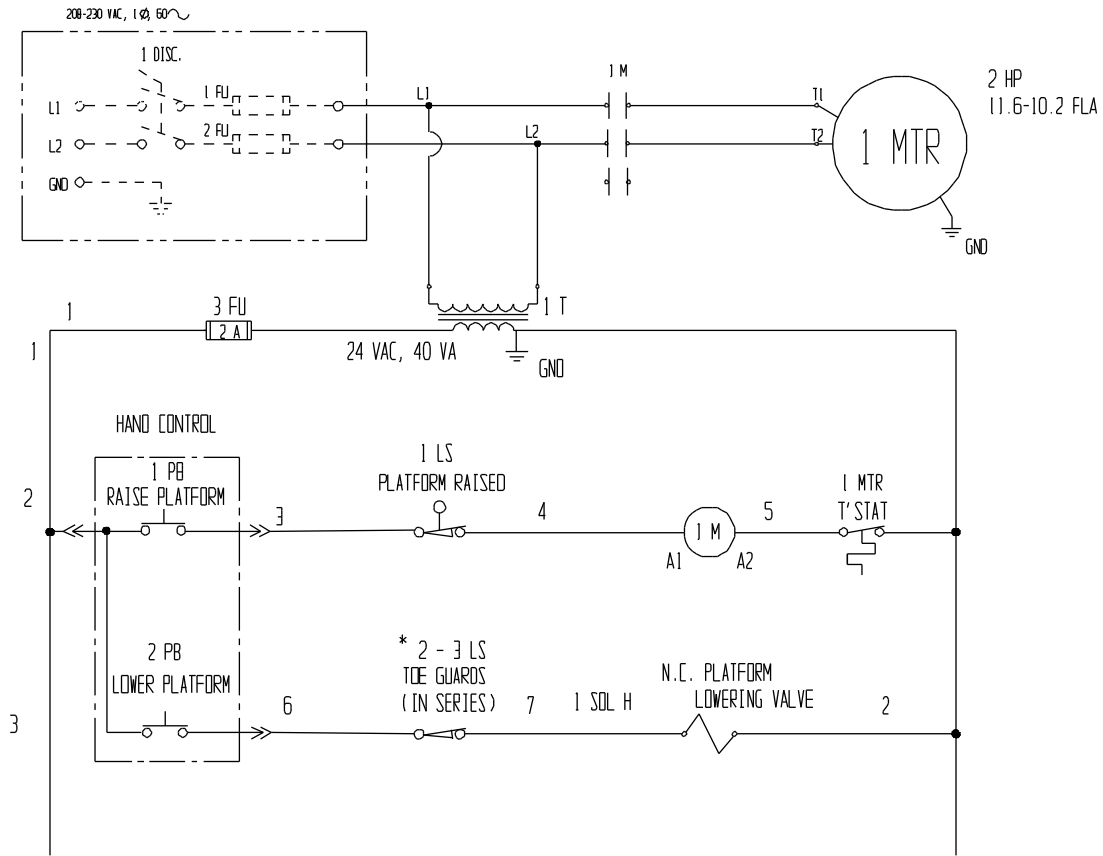

\* Number of toe guard switches can vary according to size.

### Three-Phase Electric Circuit Diagram (24124014 Rev. B)

Note: Overcurrent & short circuit protection and disconnect must be provided by end user.

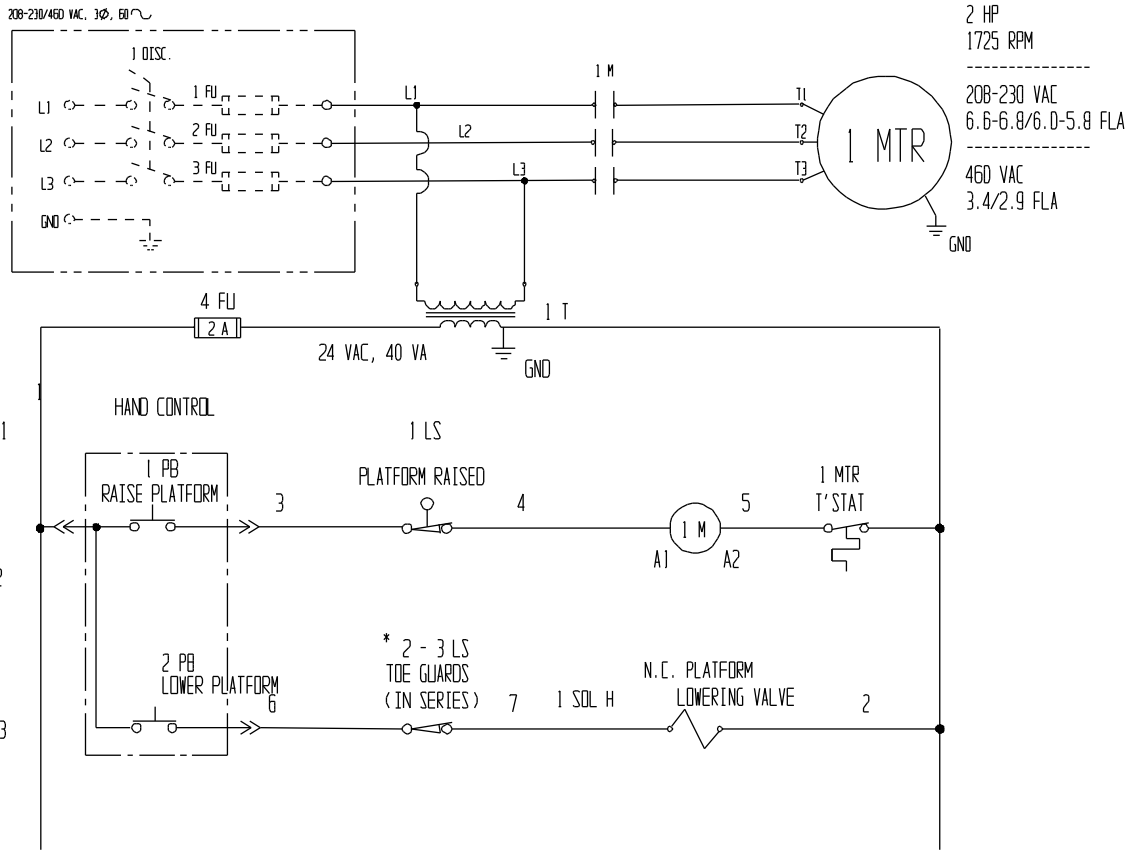

NOTES:

\* Number of toe guard switches can vary according to size.

### Motor Lead Connections (99124021).

Applicable to all .5 HP, .75 HP, and 3 HP single-phase motors, and for all 2 HP, 5.5 HP, and 6.5 HP three-phase motors.

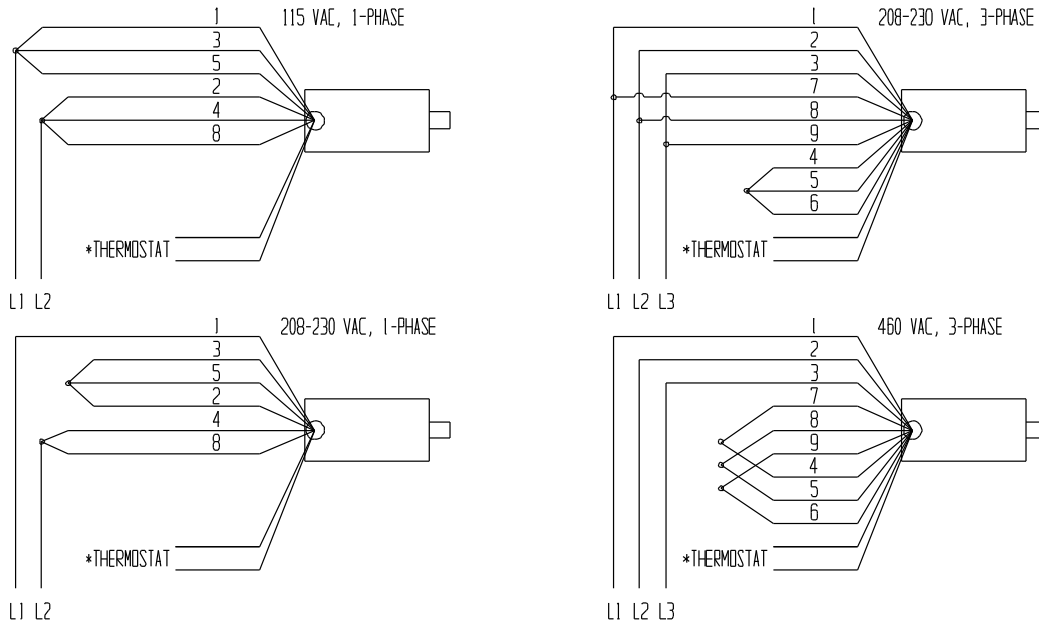

\* The two thermostat leads go to (1) the grounded side of the transformer secondary, and; (2) the motor relay coil. Polarity across the thermostat leads may be reversed.

**WARNING** When changing the motor voltage configuration, you must also change the configuration of the control transformer to match the motor voltage.

### Control Voltage Transformer (01129001 Rev. G).

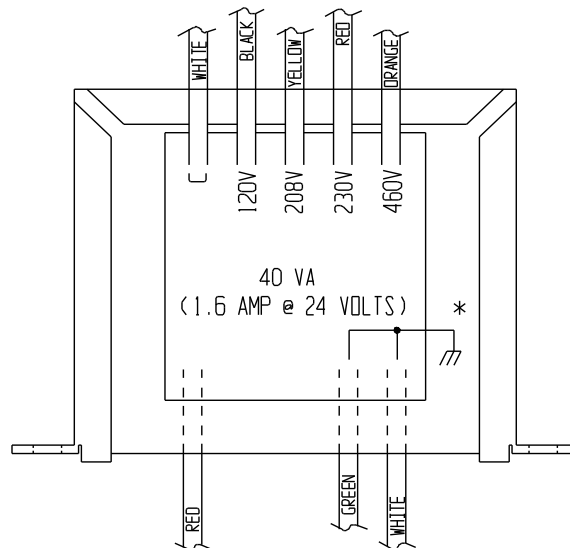

**Internal Power Unit – 2 HP, 3 PH (99-137-018).**

Contact the factory for replacement parts for your specific model. ALWAYS have the product serial number or model number on hand when calling the factory.

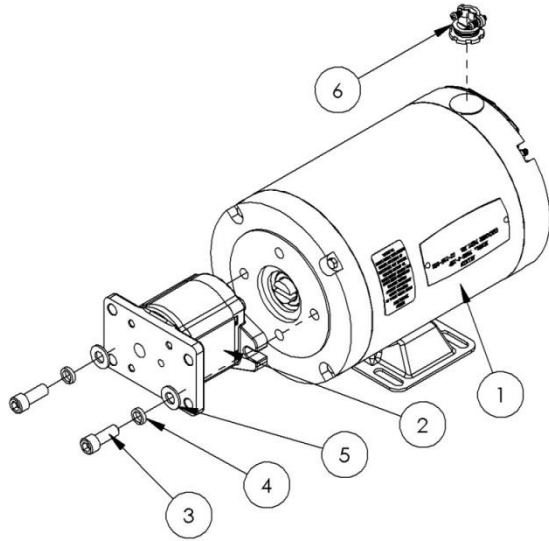

ITEM	PART NO.	DESCRIPTION	QTY
1	99-135-005	MOTOR, 2 HP, 3PH, 1725 RPM, 56F, 208-230/460V, 50/60HZ	1
2	01-143-908-002	PUMP, HYDRAULIC GEAR, .153 Disp, 2.7 cc/r	1
3	23305	SHCS, 3/8 - 16 x 1 LG.	2
4	33688	LOCK WASHER, HIGH COLLAR, 3/8	2
5	96056	WASHER, FLAT, 3/8" NOMINAL, .406" I.D., YELLOW ZINC SAE	2
6	99-034-037	ACCESSORIES, ELECTRICAL, ROMEX .375"	1

**Manifold Assembly (01-627-015 Rev. A).**

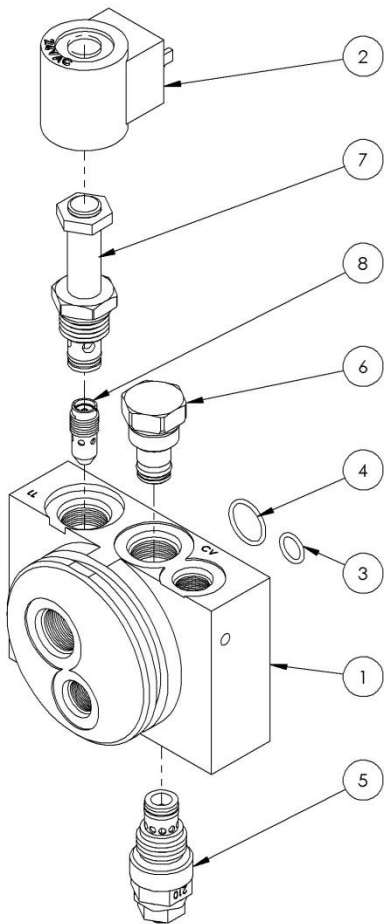

ITEM	PART NO.	DESCRIPTION	QTY
1	01-127-010	MANIFOLD, L-H-L	1
2	99-034-008	COIL WITH DIN CONNECTOR	1
3	99-144-008	O-RING, MANIFOLD, 1/2" OD	1
4	99-144-009	O-RING, MANIFOLD, 3/4" OD	1
5	99-153-006	VALVE, PRESSURE RELIEF, 210 BAR	1
6	99-153-011	CHECK VALVE, SIZE 08, NOSE-IN/SIDE-OUT	1
7	99-153-015	VALVE SOLENOID, STANDARD, w/o COIL	1
8	99-153-040	FLOW CONTROL, PRES. COMP., 2.0 GAL.	1

**Hydraulic Schematic (01-125-008).**

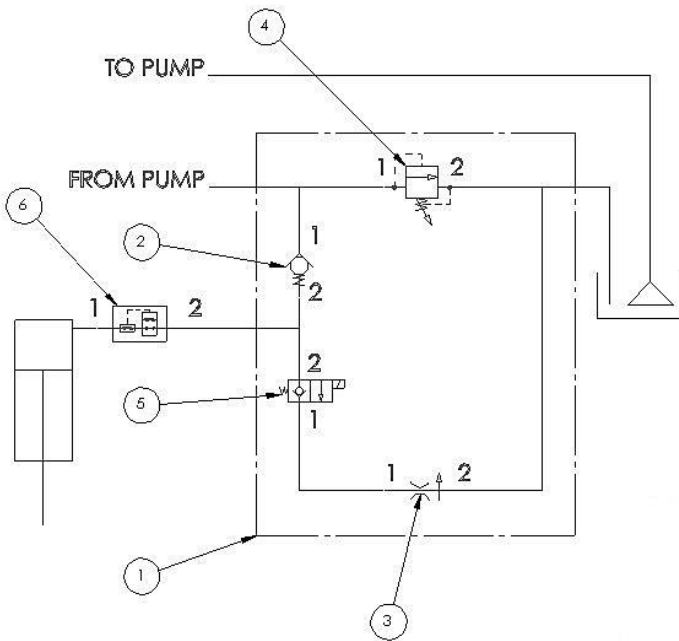

ITEM	PART NO.	DESCRIPTION	QTY
1	01-127-010	MANIFOLD, LHL	1
2	99-153-011	CHECK VALVE, SIZE 08, NOSE-IN/SIDE-OUT	1
3	0.5 GPM 99-153-049	FLOW CONTROL, PRES. COMP.	1
	1.0 GPM 99-153-038		
	1.5 GPM 99-153-039		
	2.0 GPM 99-153-040		
4	99-153-006	VALVE, PRESSURE RELIEF, 210 BAR	1
5	99-153-015	VALVE SOLENOID, STANDARD, w/o COIL	1
6	01-531-002	2.0 GPM VELOCITY FUSE <i>Multi-cylinder lift tables</i>	2-4
	01-531-003	3.0 GPM VELOCITY FUSE <i>Single-cylinder lift tables</i>	1

**External Power Unit – 2 HP, 3 PH (99-660-164).**

EHLT Lift Tables can have an optional external power unit (-RPUA option). The power unit subassembly and manifold assembly (item 3) are identical to those of the internal power unit.

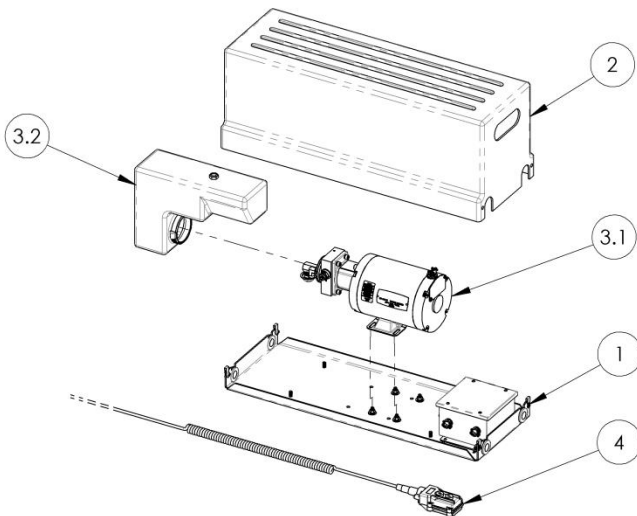

ITEM	PART NO.	DESCRIPTION	QTY
1	VARIOUS	BASE, REMOTE POWER UNIT (INCL. ELECTRICAL COMPONENTS)	1
2	99-024-041	COVER, REMOTE POWER UNIT	1
3	99-160-075	POWER UNIT, SUB-ASSEMBLY, 208-230/460V AC, 3 PH, 2 HP, 1725 RPM, 0.153 DISP., 2.0 GPM FLOW CONTROL, L-H-L	1
3.1	99-137-018	MOTOR/PUMP, 460V AC, 3 PH, 2 HP, 1725 RPM, 0.153 DISP	1
3.2	99-023-002	RESERVOIR, 3" BOSS	1
4	99-522-035	ASSEMBLY, HAND CONTROL (2-BUTTON), CORD, COILED, 18/3, 18"-90", 48" TAIL, 3-PIN MOLDED MALE PLUG	1

## **INSTALLATION INSTRUCTIONS**

Review this entire section before installing the scissor lift table.

Consult the factory in the event of questions or problems at the time of installation.

Modifications or additions to the lift table, without prior authorization by the manufacturer, may void the warranty. See ANSI standard MH29.1-2003, *Safety Requirements for Industrial Scissor Lifts*, Section 12.6. Attaching ancillary equipment to the platform will lower its load capacity.

The installation shall comply with all applicable regulations for its location and use.

The end user is responsible for verifying that this lift table and its installation are suitable for its environment and application.

This lift table shall be installed only by qualified and trained personnel with access to appropriate equipment. Electrical connections shall be performed by a qualified electrician.

### **Before You Begin.**

The Electric Hydraulic Scissors Lift Table must be anchored to a smooth, level, and adequately strong concrete surface. See the INSTALLATION DIMENSIONS diagram and table to plan your installation.

If the lift table is to be placed in a pit, first determine where and how the electrical and/or hydraulic connections will be made for when the lift table is in place.

### **Tools and Supplies.**

The following tools and supplies may be needed to install your Electric Hydraulic Scissor Lift Table. These items are not supplied with the product.

- A fork truck or hoist capable of unloading the lift table and setting it in place.
- A smooth, level concrete surface on which to mount the lift table.
- Four concrete anchors. The customer is responsible for selecting anchors appropriate for the EHLT model and concrete floor conditions. DO NOT operate an unsecured lift table.
- A power supply and electrical disconnect matching the motor's voltage and current requirements. Refer to the lift table's data plate, labels on the control enclosure, and the electrical diagrams in this manual for more information. The end-user is responsible for supplying the required ground-fault and short-circuit protection on the supply. Motor overload protection is provided by a thermostat built into the motor.

### **Installation Dimensions.**

The bottom view of EHLT is shown. Dimensions listed for quick-ship items. Contact the factory for other lift table sizes. When installing in a floor pit, provide a clearance of at least 1/4" but no more than 7/8" clearance on all sides.

**INSTALLATION DIMENSIONS, EHLT-SERIES**

BOTTOM VIEW OF TABLE

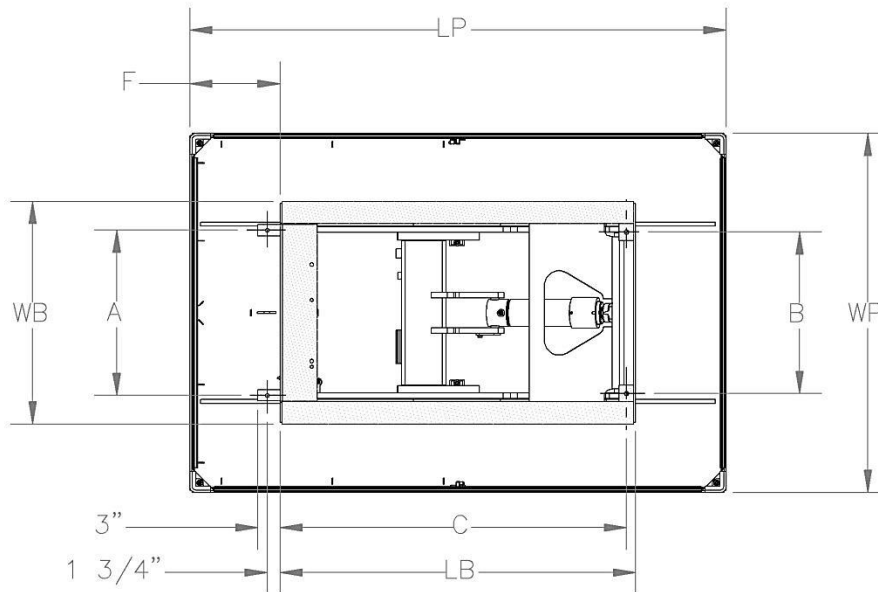

LOCATION: C:\PDM Vault\Archive\24\

FILE: 24-006-628.SLDDRW

2/26/2020

MODEL*	BASE DIMENSIONS					PLATFORM DIMENSIONS		
	WB	LB	A	B	C	WP	LP	F
EHLT-2448-#-##	24"	48"	16-1/4"	15-3/4"	46-3/4"	24-3/8"	48-3/8"	1/4"
EHLT-3060-#-##	30"	48"	21-3/4"	22-1/4"	48-1/2"	30-3/8"	60-3/8"	6.18"
EHLT-4048-#-##						40-3/8"	48-3/8"	0.37"
EHLT-4848-#-##						48-3/8"	48-3/8"	0.37"
EHLT-4872-#-##						48-3/8"	72-3/8"	12.18"
EHLT-2448-#-##-PSS	24"	48"	16-3/8"	15-3/4"	46-3/4"	24-3/8"	48-3/8"	3/16"
EHLT-4848-#-##-PSS	30"	48"	22-7/16"	21-3.4"	46-3/4"	48-3/8"	48-3/8"	3/16"

\* For other models, consult your sales representative or the factory.

**Installation.**

1. The platform must be lowered and fully supported under its frame when moved. Support the lift table with straps or forks that span the entire width or length of the base frame. Remove the 4x4 wood dunnage from the base. Use care to avoid damaging the electrical and hydraulic components in the lift table.
  - a. Some high-capacity units are shipped with eyebolts protruding through the platform. These units may be lifted by the eyebolts. Remove the eyebolts before operating the platform.
2. Move the lift table into position.
3. Temporarily connect the power supply to the power cable supplied with the lift table. Raise the platform near to its full raised height. Rotate both of the temporary maintenance props forward so that their free ends drop down onto the base frame. Lower the platform until the props slide up against the end of the base frame.

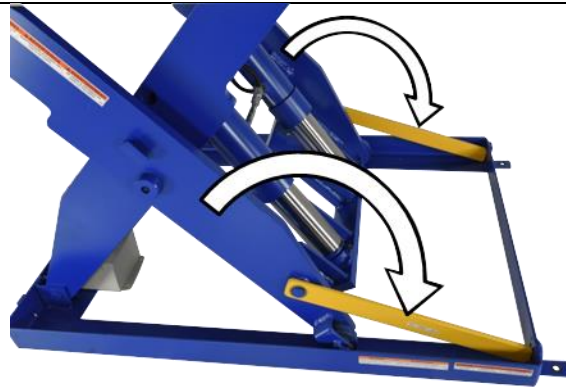

To raise the platform without using a power supply, use a hoist with straps or chain rigging, or the forks on a lift truck. Lift from the hinged end of the platform. Take care not to damage the aluminum perimeter toe guard under the platform. Use the 4x4 wood dunnage to secure the base while lifting the platform.

- a. Some EHLT models use drop-in maintenance props in lieu of the rotating stops. When not in use, these are stored on the base near the fixed hinge. To engage, move both props to the side rail in front of the rollers.

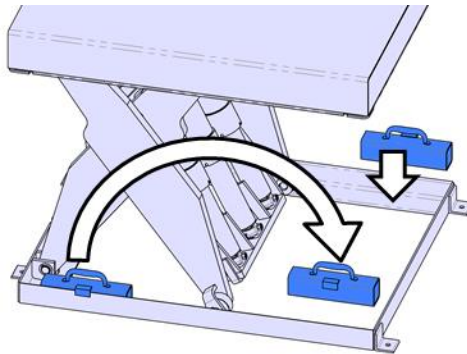

- b. Some EHLT models use flip-over maintenance props in lieu of the rotating stops. To engage, flip both props to the inside of the side rail.

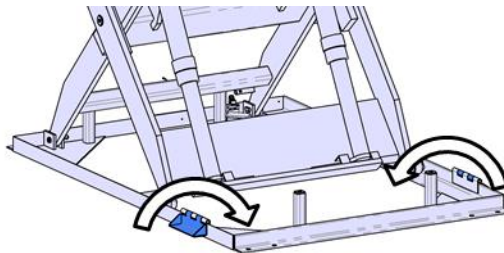

4. Anchor the frame to the floor through the four mounting holes in the frame.
5. Shim and/or grout to ensure the entire length of each base side frame is level and fully supported. The entire base frame rail must be supported with no gaps in its foundation for the lift table to function properly.
6. Have a qualified electrician make a permanent connection to the power supply.
7. Operate the lift table through several full raise and lower cycles. Verify that actuating the upper travel limit switch (mounted on the base frame, near the left-side hinge) prevents further upward travel of the platform. Verify that actuating the perimeter toe guard switches (under the platform) from any side of the lift table prevents further downward travel of the platform. **DO NOT** place a lift table in service if either of these devices isn't functioning properly.

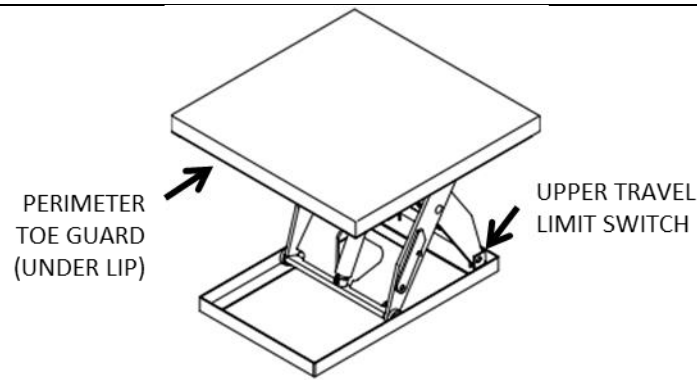

8. Check the hydraulic oil level. It should be filled to within 1" to 1-½" of the reservoir's fill hole. *Note: the reservoir is an integral part of the scissor mechanism on many models.* If oil is needed, use an anti-wear hydraulic oil with a viscosity grade of 150 SUS at 100°F (ISO 32 at 40°C) or a non-synthetic automatic transmission fluid.
9. Clean up any debris or spilled oil. Verify that all of the information, safety, and warning labels are in good condition.

## **RECORD OF SATISFACTORY CONDITION**

After assembling and installing the scissor lift table, and before using it for the first time, make a record describing its appearance. Thoroughly photograph the lift table from multiple angles, including all welds and anchor points, and all labeling applied to it. Describe where each label is located. Collect all photographs and writings into a file. Mark the file appropriately to identify it. This record documents satisfactory condition. Compare the results of future inspections to this record to determine if the lift table is in satisfactory condition. Do not use the lift table unless it is in satisfactory condition. Purely cosmetic changes, like damaged paint or powder coat, do not constitute changes from satisfactory condition. However, touchup paint should be applied to all affected areas as soon as damage occurs.

## **OPERATION INSTRUCTIONS**

*Consult ANSI standard MH29.1, Section 12 for the owner's/user's responsibilities regarding the operation, care, and maintenance of this machine.*

*The user shall ensure that only authorized operators use a lift table. The user shall ensure that operators understand that safe operation is the operator's responsibility. The user shall ensure that operators are trained by a qualified person, and demonstrate proficiency in the safe and proper operation of a lift table.*

The standard-model scissor lift table is suitable for use indoors in most non-classified industrial locations and many commercial locations. It is intended to lift stable, evenly-distributed, nonhazardous materials loads having a size or footprint approximately the same size as the platform.

The drawing identifies the major components of your scissors lift table.

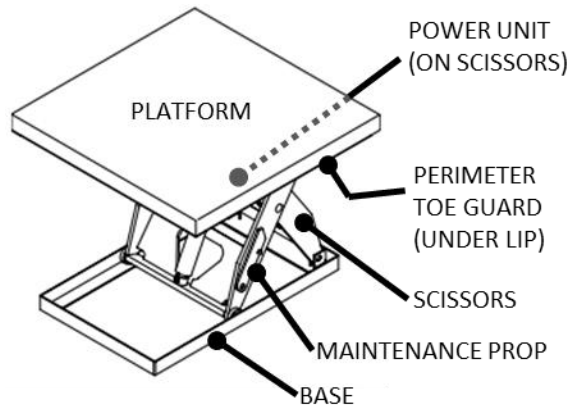

**Loading the platform.**

The load rating, in pounds, is shown on the machine data plate located on the hinged end of the platform. This indicates the net capacity of the scissor lift table for a static load, centered and evenly distributed on the platform. For off-center loads, the lift table's maximum capacity is 75% of the rated capacity for end loading (either end), and 50% for side loading (either side) (see diagram, next page).

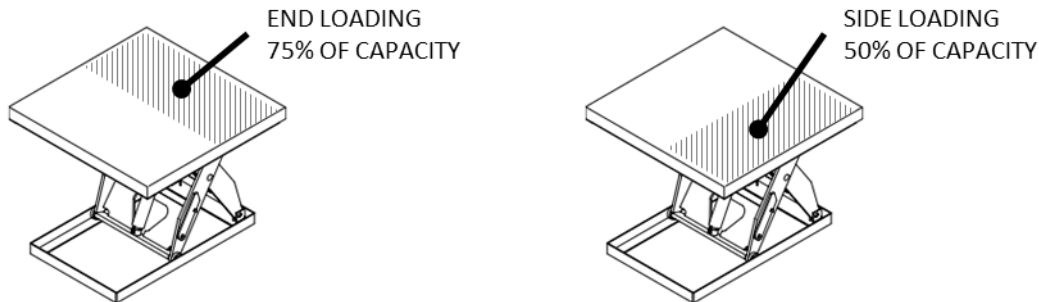

<p><b>⚠ WARNING</b></p>	<p><i>DO NOT exceed the lift table's load ratings. Injury to personnel or permanent damage to the lift table can result from exceeding the listed capacity. Note: Take into account the weight of any equipment added to the platform by third parties when determining the maximum working load to be placed on the platform.</i></p>		
<p><b>⚠ WARNING</b></p>	<p><i>The platform rollers are not captured. DO NOT overhang any load over the side of the platform. A cantilevered or overhanging load at the hinged end can cause the platform to tilt and dump the load. For applications involving side or end edge loading, consult the factory.</i></p>		
<p><b>⚠ WARNING</b></p>	<p><i>This lift table is not approved for lifting personnel.</i></p>		
<p><b>⚠ WARNING</b></p>	<p>Always use vertical motion to place or remove a load from a lift table when using a forklift. Avoid sliding a load across the table surface.</p>		

## Operation.

At the beginning of every shift, perform the **Daily inspection** tasks listed in the INSPECTION AND MAINTENANCE SECTION of this Manual. This includes a test of the perimeter toe guard for correct operation. First raise the platform. Push and hold a section of the perimeter toe guard up against the platform. The platform should not move when the "LOWER" button is pressed. Perform this check on all four sides of the platform.

Check the condition of the guards, controls, scissor mechanism, hydraulic lines, and limit switches. If any item is in need of repair or otherwise contributes to an unsafe condition, remove the lift table from service until it has been restored to a safe operating condition.

The standard EHLT scissor lift table is furnished with either an internally- or externally-mounted electric-hydraulic power unit and a handheld pushbutton control.

- Press the "RAISE" pushbutton to energize the power unit and raise the platform. The platform will rise only while the pushbutton is pressed. When the pushbutton is released, the platform will stop and hold its position. At the platform's maximum height, a limit switch prevents the platform from further raising.
- Press the "LOWER" pushbutton to open the hydraulic valve and lower the platform. The platform descends by gravity, and the pump motor will not run. Release the pushbutton to stop the motion of the platform. If the perimeter toe guard encounters an object, the valve will close and prevent further descent of the platform.
- The EHLT lift table is provided with hydraulic overload protection that will prevent it from raising a load in excess of its rated capacity. The lowering speed is preset at the factory, and will not exceed a speed of 30 fpm. In the event of a hydraulic line failure, a velocity fuse internal to the cylinder will prevent the platform from lowering.
- Lift tables with external modular power units have pushbutton controls and a key switch in the power unit cover. The key switch must be turned to the "ON" position to operate the controls.

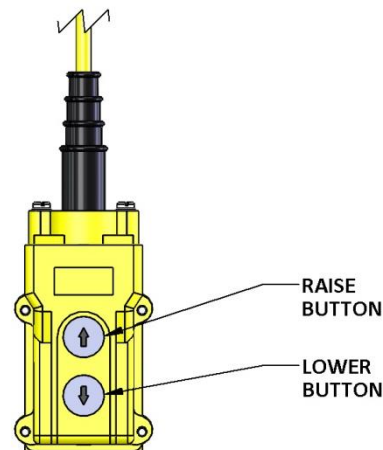

### ⚠ CAUTION

*Always watch the area around the platform and any load on the platform when it is in operation.*

### ⚠ CAUTION

*Never use the lift table if any damage or unusual noise is observed, if it is in need of repair, or if any other malfunction is observed. Notify your supervisor or maintenance personnel.*

### ⚠ WARNING

*Keep all personnel clear of the machine when it is in operation. Before operating the lift table, make certain no part of any person or object is under the platform.*

### ⚠ WARNING

*Guards shall be in place before operating the lift table.*

### ⚠ WARNING

*Guards cannot protect against every possible condition, and should not be considered a substitute for good judgment and care in use, loading, handling, storage, etc. of the lift table.*

## **INSPECTION AND MAINTENANCE**

Proper maintenance is essential for maximizing the service life of this product. If an inspection reveals any irregularities in the lift table's condition, repair it before returning it to service. Only use manufacturer-approved replacement parts. Contact Technical Service if you have questions that are not addressed in these instructions or if you are uncertain how to address an issue discovered during an inspection. Technical Service can be contacted by calling (260) 665-7586 and asking for the Service and Parts Department or by submitting questions online at [http://www.vestilmfg.com/parts\\_info.htm](http://www.vestilmfg.com/parts_info.htm).

**⚠ WARNING**

*Care should be taken to identify all potential hazards and comply with applicable safety procedures before beginning work.*

**⚠ WARNING**

*Remove any load and install the maintenance props before beginning any inspection or service on the lift table. See below.*

*Only qualified individuals trained to understand mechanical devices, electrical and hydraulic circuits, and the hazards associated with them, should attempt troubleshooting and repair of this equipment.*

### **Inspection procedures.**

Prior to performing any inspection or maintenance on this lift table:

- Read and understand these maintenance procedures.
- Remove the load from the platform. Do not attempt to service a loaded lift table.
- Fully lower the platform, OR use both maintenance props to support the weight of the platform. To use the maintenance props, raise the platform to its full height. Rotate both props forward so that their free ends drop down into the lift table's frame. Lower the platform until the maintenance props slide up against the end of the frame.
- With the weight of the platform supported by the maintenance props, press and hold the LOWER button for three seconds to relieve any residual hydraulic pressure.
- Disconnect power and follow established lockout/tagout policies as required.

### **Initial inspection.**

Prior to use, any new, altered, modified, or repaired scissor lift table shall be inspected by a qualified person. Complete both the daily and monthly inspection items before releasing the lift table for regular use.

### **Daily inspection.**

At the beginning of every shift, a designated person shall complete these inspections. Remove the lift table from service and repair or replace any damaged parts if any of the following is found.

1. Look for:
  - a. Frayed wires.
  - b. Oil leaks.
  - c. Pinched, chafed, worn, or cracking hydraulic hoses.
  - d. Damage, deformation, or cracks in any structural member or any weld. Give special attention to the hydraulic cylinder mounting brackets.
  - e. Loose or missing fasteners.
  - f. Unusual noise or evidence of binding.
2. Test the function of the upper travel limit switch and the perimeter toe guard.
3. Check the area surrounding and above the lift table for floor conditions/obstructions, overhead obstructions, or other possible unsafe use conditions.

### Monthly inspection.

Have a qualified person inspect for:

1. Oil level. The oil should be 1" to 1-½" below the reservoir fill hole with the platform in the fully lowered position. See the Annual Inspection section for the hydraulic oil specification.
2. Worn or damaged hydraulic hoses or electrical wires.
3. Wear in the pivot points on the legs.
4. Looseness or wear in the rollers.
5. Integrity of the retaining hardware on all rollers and all pivot point pins.
6. Integrity of the frame anchor bolts, and for cracks in the concrete around them.
7. Proper functioning of any hand- or foot-operated mechanisms.
8. Unusual noises or movement during operation.
9. Condition of all information, safety, and warning labels. These should be clean and clearly legible.
10. Dirt and debris. Clean, sweep, or wipe down as needed.

### Annual inspection.

Check the condition of the oil. Change the oil if it darkens, becomes gritty, or turns a milky color (indicating the presence of water). Replace with an anti-wear hydraulic oil with a viscosity grade of 150 SUS at 100°F (ISO 32 cSt @ 40°C), such as AW 32, HO 150 or Dexron non-synthetic transmission fluid. You may use a synthetic transmission fluid if you flush the system with the synthetic fluid before filling the reservoir. 150 SUS at 100°F (ISO 32 cSt @ 40°C) or Dexron transmission fluid.

### Solenoid valve maintenance.

In the event that the platform creeps down slowly after releasing the "DOWN" control, it will be necessary to remove the lowering cartridge valve for inspection and cleaning.

1. Remove any load from the platform.
2. Raise the platform. Lower the maintenance props into the side frame. Lower the platform until it rests on the props.
3. On most EHLT models, the power unit is attached to the hinged side of scissor lift mechanism. The manifold assembly is attached to the end of the power unit.
4. Remove the nut holding the solenoid coil (item (2), right) on the solenoid valve stem. Remove the coil (2), then unscrew the valve (7) from the manifold.
5. Inspect the valve for contaminants. Inspect the O-rings and back-up washers for cuts, tears, or other damage.
6. With the valve immersed in mineral spirits or kerosene, insert a thin tool such as a small screwdriver or a small hex wrench in the hole at the bottom of the valve (illustration, next page). Push the spool in and out several times. A properly functioning spool should move freely, with about 1/16" of travel. Use mineral spirits to flush the valve.
7. If the spool continues to stick, the stem could be bent. The valve will need to be replaced.
8. Blow the valve off with a compressed-air gun while again pushing the spool in and out.
9. Inspect the bottom of the manifold's valve cavity for contaminants.

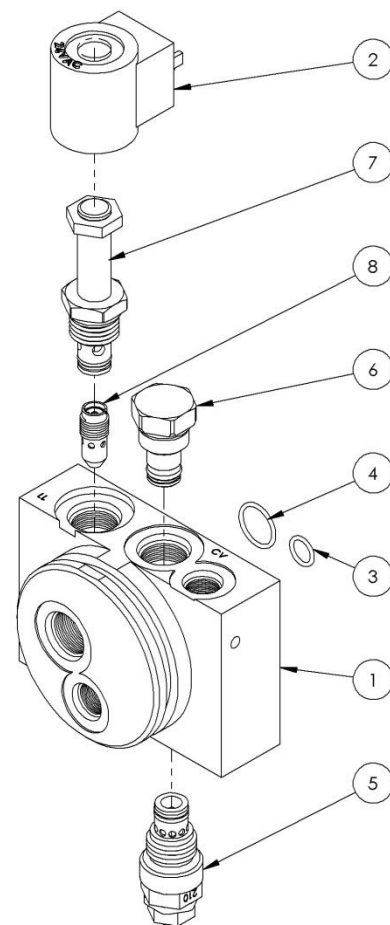

10. Make sure both O-rings and outer seal (flat) are seated on the valve body. Make sure the screen filter is in place and seated at the bottom of the threads on the valve body (illustration).
11. Reinstall the solenoid valve, tightening to 20 ft-lb of torque. Reattach the solenoid coil and the retaining nut.

**SOLENOID VALVE**  
99-153-015



### Bleeding the hydraulic cylinder.

Air can enter the hydraulic system at any time its components are opened for service. Symptoms of air in the system include erratic or bouncing motion of the platform, sponginess in holding position, unusual noises, or foaming in the hydraulic fluid. Trapped air can also trigger the cylinder's velocity fuse, slowing or preventing the cylinder from lowering.

Cycling the platform up and down without a load can expel much of the trapped air through the hydraulic reservoir. If it becomes necessary to bleed air from the system:

1. Remove any load from the platform.
2. Raise the platform. Lower (or insert) the maintenance props into the side frame. Lower the platform until the props are about  $\frac{1}{2}$ "-1" away from the end of the frame. Some motion is necessary to expel air from the system.
3. Hold a rag over the cylinder's bleeder valve to capture expelled oil. The valve is located at the top of the cylinder (see illustration). Use a  $\frac{1}{4}$ " wrench to open the valve about a half-turn.
4. Oil and air will sputter from the valve. Once no more air comes out, close the valve.
5. For multi-cylinder lift tables, it will be necessary to open the bleeder valves on all cylinders simultaneously in order to bleed the valves.

### BLEEDING THE HYDRAULIC CYLINDER

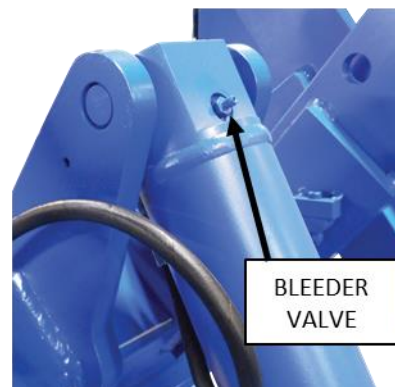
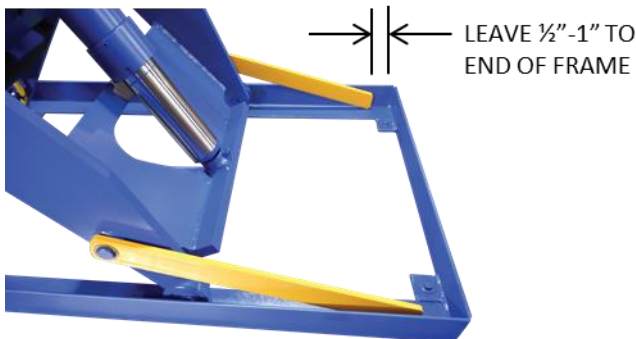

## TROUBLESHOOTING GUIDE



**WARNING**

Care should be taken to identify all potential hazards and comply with applicable safety procedures before beginning work.



**WARNING**

Remove any load and install the maintenance props before beginning any inspection or service on the lift table. See below.

Only qualified individuals trained to understand mechanical devices, electrical and hydraulic circuits, and the hazards associated with them, should attempt troubleshooting and repair of this equipment.

Consult the factory for any problems not addressed in this manual. ALWAYS have the product serial number or model number on hand when calling the factory.

PROBLEM	POSSIBLE CAUSES	ACTION
Power unit doesn't run when "UP" button is pressed.	Transformer fuse is blown.	Test with meter. Replace if bad.
	No supply voltage.	Test with meter. Check fuses, breakers, and overloads to determine the cause
	Upper-travel limit switch is engaged or bad.	Inspect and test switch. Replace if bad.
	Bad control transformer.	Check for 24 VAC at secondary. Replace if bad.
	Bad motor relay coil.	Test with meter. Replace if bad.
	Bad solenoid start switch (DC units).	The green LED on motor relay will be off, or will turn off when the UP pushbutton is pressed.
Motor runs but platform doesn't move. Power unit not noisy.	Battery voltage low (DC units).	Test with meter. Charge battery if low (is the motor relay LED on?)
	Eye bolts not removed at installation.	Remove eye bolts.
	Motor rotation is wrong (AC-powered units only).	Verify the motor runs CW, opposite the shaft end.
Motor hums or pump squeals, but the platform does not move, or the platform moves only slowly.	Pump is failing to produce pressure.	Consult factory.
	Excess voltage drop to motor, due to power wire size too small, wire run too long, or incoming voltage too low.	Check the power installation for adequacy. Check the incoming voltage <i>while the motor is running</i> . Correct any problems found.
	Motor is "single-phasing".	Determine and correct cause of voltage loss on phase.
	Pressure relief opening at full pressure.	Check for structural damage or binding of the scissor legs, etc. Check for platform overload condition.
	Contamination holding open the lowering valve or the check valve.	Remove and inspect valves. Clean per instructions in the "Inspection and Maintenance" section.
Platform raises, then drifts down.	Contamination holding open the lowering valve or the check valve.	Remove and inspect valves. Clean per instructions in "Inspection and Maintenance" section.
Spongy or jerky platform movement.	Excessive air in the hydraulic cylinders.	Bleed air per procedure described in the "Inspection and Maintenance" section.
Platform won't lower.	Perimeter toe guard actuated.	Check for a toe guard extrusion or rubber corner that is stuck. Adjust if necessary.
	Perimeter toe guard switch or wire broken.	Inspect visually; check with multimeter. Repair as needed.
	Solenoid coil is bad.	Check with multimeter using the diode-check function. (Reading for ohms will not provide an accurate test of the coil). Replace if bad.
	Physical blockage of the mechanism.	Inspect for foreign material or objects blocking the scissors or the rollers.
	Solenoid valve, flow control, or suction hose screen plugged.	Remove and inspect valves. Clean per instructions in "Inspection and Maintenance" section.
Platform lowers too slowly.	Solenoid valve, flow control, or suction hose screen plugged.	Remove and inspect valves. Clean per instructions in "Inspection and Maintenance" section.
	Velocity fuse locking (indicated by platform only slowly creeping down).	Check for air in hydraulic system. Bleed air as needed.
	Flow control valve spool sticking.	Remove and inspect valves. Clean per instructions in "Inspection and Maintenance" section.
Platform lowers too quickly.	Flow control valve spool sticking.	Remove and inspect valves. Clean per instructions in "Inspection and Maintenance" section.

## LABELING DIAGRAM

The lift table should be labeled as shown in the diagrams. However, label content and location are subject to change so your product might not be labeled exactly as shown. Thoroughly photograph the lift table when you first receive it as discussed in the Record of Satisfactory Condition section on p. 16. Make sure that your record includes a photograph of each label. Replace all labels that are or later become damaged, missing, or not easily readable (e.g. faded).

To order replacement labels, contact the technical service and parts department online at [http://www.vestilmfg.com/parts\\_info.htm](http://www.vestilmfg.com/parts_info.htm). Alternatively, you may request replacement parts and/or service by calling (260) 665-7586 and asking the operator to connect you to the Parts Department.

# EHLT

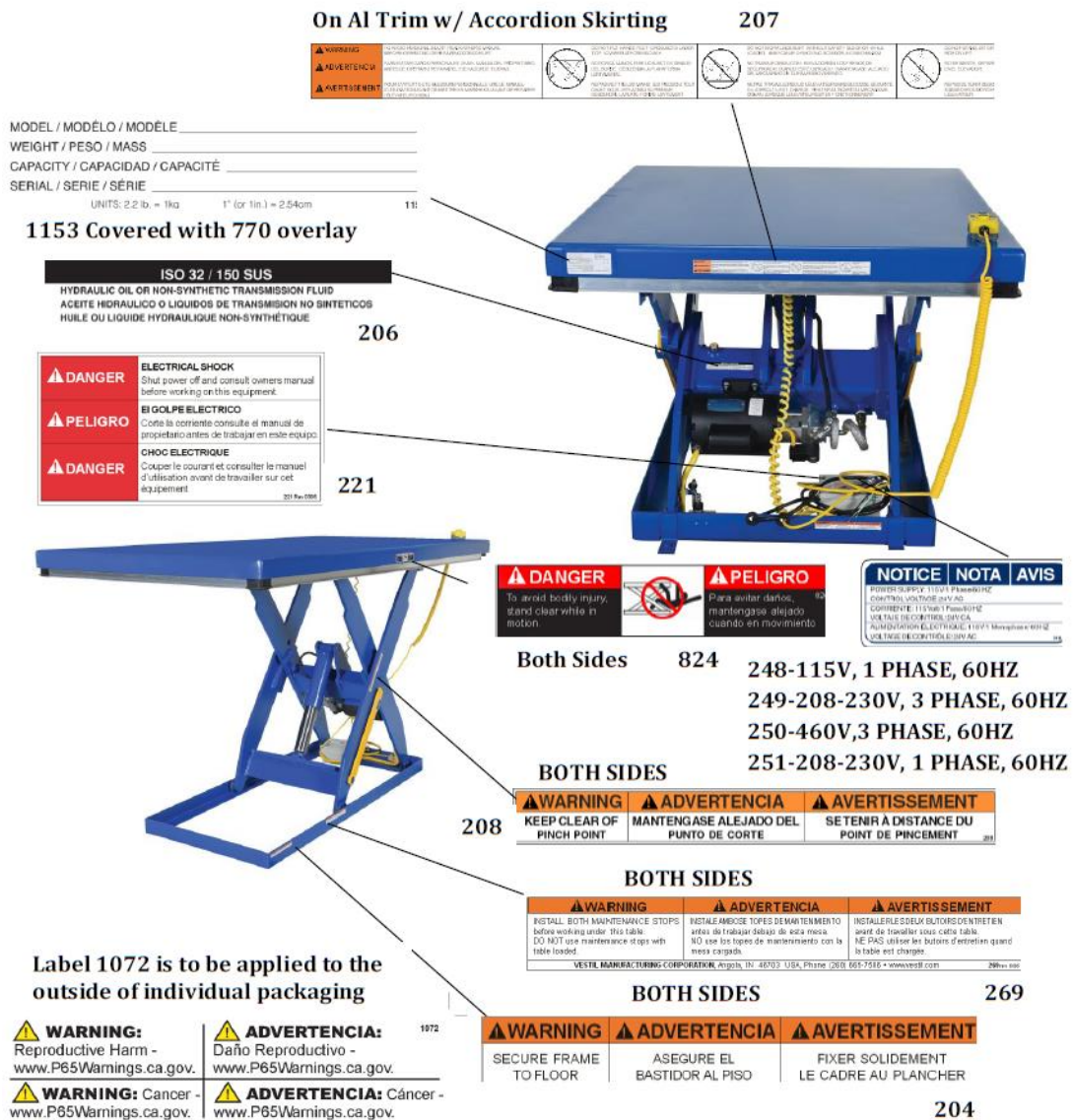

# ELECTRIC HYDRUALIC SCISSOR LIFT TABLES

5-17-2022

## APPENDIX: BILLS OF MATERIAL FOR HIGH-CAPACITY MODELS

Tables having a capacity between 8000 lb and 12,000 lb all use an external 6-½ hp Power Unit Assembly.

### Base Assembly Exploded View (44" 8000-lb unit depicted)

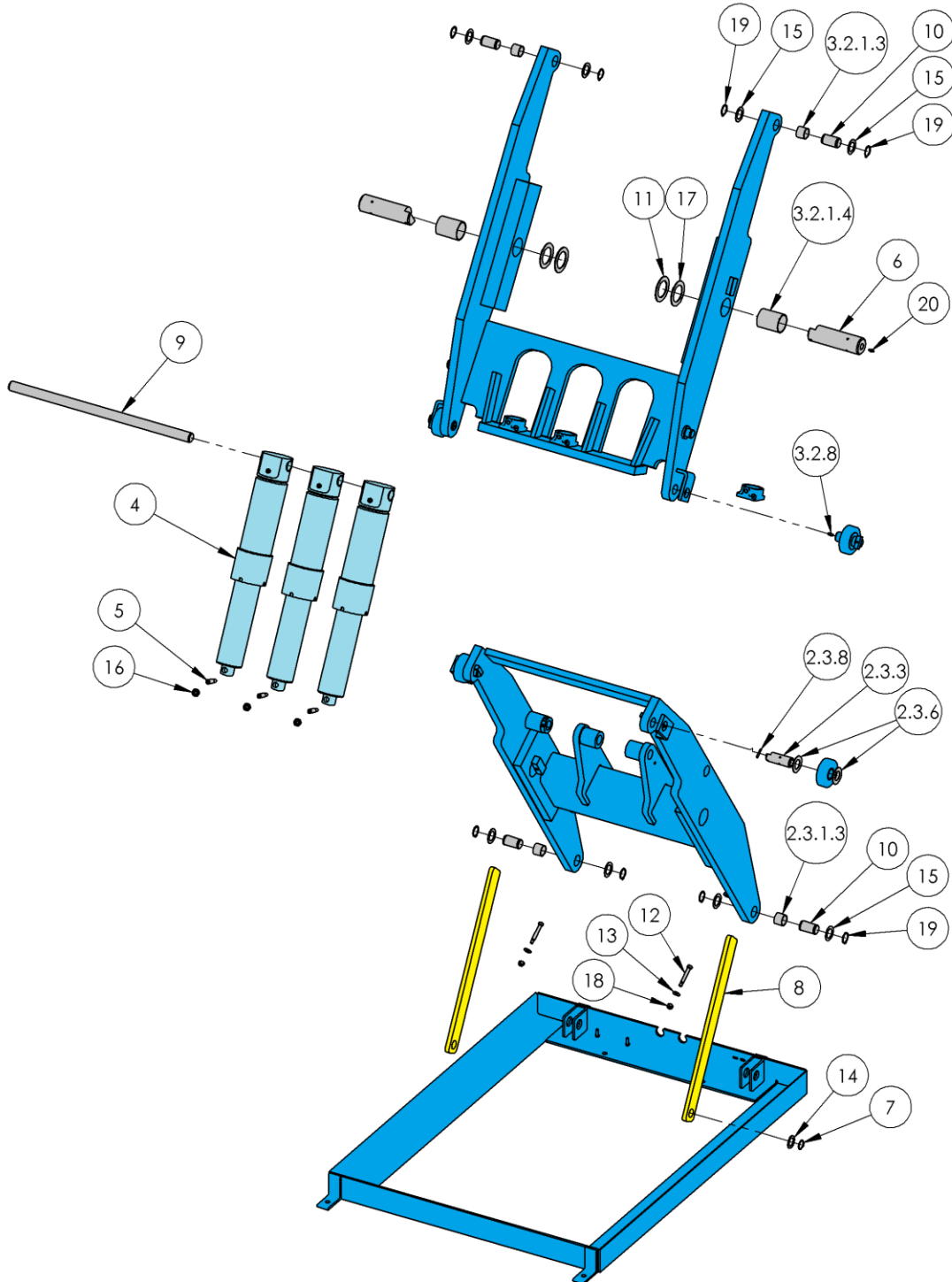

**EHLT 8k Base Assembly Bill of Materials**

ITEM	PART NUMBER	DESCRIPTION	QTY
2.3.1.3	01-111-005	BUSHING, POLYGON 1 1/8 ID X 1 LG	8
2.3.3	05-112-002-001	PIN, HINGE	4
2.3.6	01-115-001	WASHER, THRUST BEARING, 1 1/8 ID	4
2.3.8	64134	SPRING PIN	4
3.2.1.3	01-115-001	WASHER, THRUST BEARING, 1 1/8 ID	4
3.2.1.4	01-111-017	BUSHING, POLYGON 2 ID X 2 3/4 LG	1
3.2.8	5546062	GREASE ZERK, 3/16", STRAIGHT, DRIVE-IN	4
4	99-021-901-001	CYLINDER, HYDRAULIC, Ø3" x 10" RAM STYLE, MACHINED END	2 or 3
5	01-118-001	BOLT, CYLINDER RETAINING	3
6	05-112-301	PIN, AXLE	2
7	20-117-003	EXTERNAL RETAINING RING, 1" DIA SHAFT	2
8	24-037-001	MAIN PROP, EHLT	2
9	24-112-004	PIN, CYLINDER PIVOT	1
10	26-112-001	PIN, HINGE	4
11	99-115-001	WASHER, THRUST	2
12	26335	SHOULDER SCREW, GRADE 2, 0.375x2" LG	2
13	33006	FLAT WASHER,ZINC PLATED,USS, Ø5/16"	2
14	33444	MACHINE BUSHING, Ø 1 X 18 GA.	2
15	33454	NARROW MACHINERY BUSHING, PLAIN FINISH, 1 3/4" X 18 GA	8
16	36209	1/2 - 13 HEX JAM NUT PLAIN, GRADE A	3
17	33495	2 ID X 3 OD X 14 GA. MACHINE BUSHING	2
18	37021	NYLON INSERT LOCK NUT, GRADE 2, ZINC FINISH, 5/16"-18	2
19	68021	EXTERNAL RETAINING RING, PHOSPHATE FINISH, 1-1/8"	8
20	5546062	GREASE ZERK, 3/16", STRAIGHT, DRIVE-IN	2

*Representative BoM. Details vary by specific model. Contact the factory for details regarding your specific Table.*

**Base Assembly Exploded View (43" 12,000-lb unit depicted)**

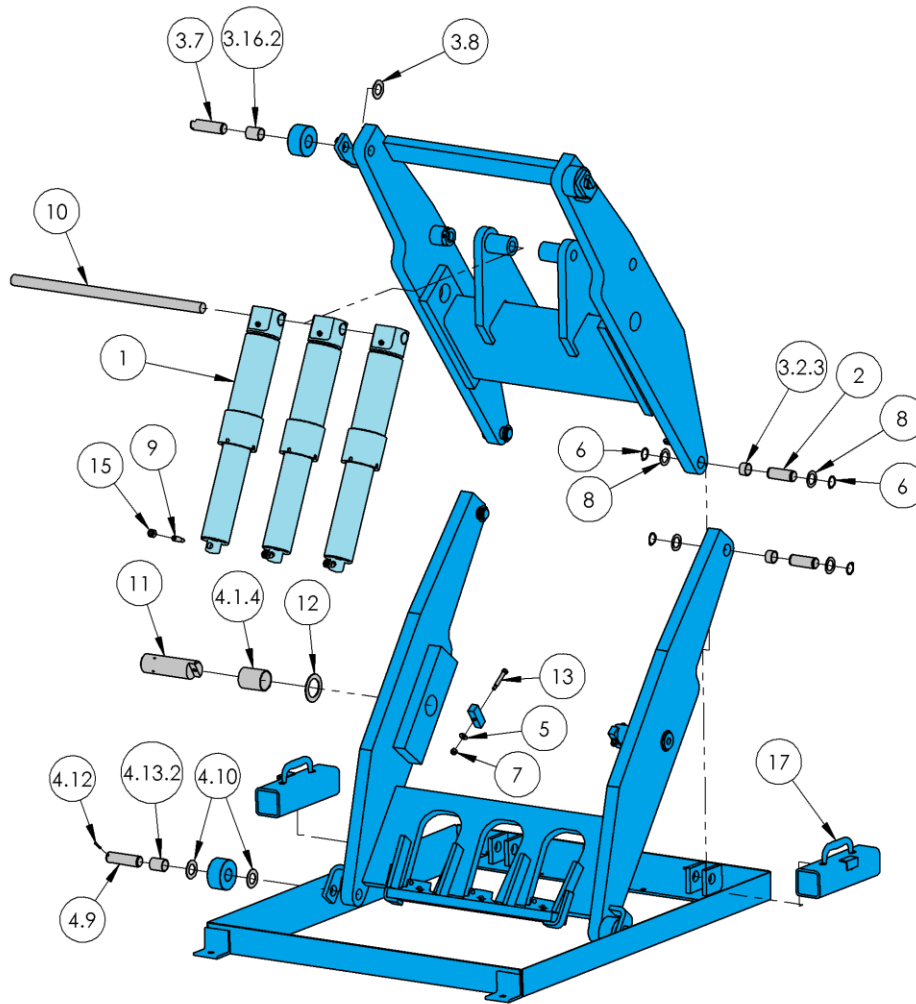

**EHLT 12k Base Assembly Bill of Materials**

ITEM	PART NUMBER	DESCRIPTION	QTY
1	99-021-901-001	CYLINDER, HYDRAULIC, Ø3" x 10" RAM STYLE, MACHINED END	3 or 4
2	25-112-001	CLEVIS PIN, HINGE	4
3.2.3	01-111-002	BUSHING, POLYGON 1 1/8 ID X 3/4 LG	8
3.7	05-112-003	PIN, ROLLER	2
3.8	01-115-001	WASHER, THRUST BEARING, 1 1/8 ID	4
3.16.2	01-111-023	BUSHING, POLYGON 1 1/8 ID X 1 9/16 LG	1
4.1.4	01-111-017	BUSHING, POLYGON 2 ID X 2 3/4 LG	2
4.9	05-112-003	PIN, ROLLER	2
4.10	01-115-001	WASHER, THRUST BEARING, 1 1/8 ID	4
4.12	64134	SPRING PIN	4
4.13.2	01-111-023	BUSHING, POLYGON 1 1/8 ID X 1 9/16 LG	1
5	33006	FLAT WASHER,ZINC PLATED,USS, Ø5/16"	2
6	68021	EXTERNAL RETAINING RING, PHOSPHATE FINISH, 1-1/8"	8
7	37021	NYLON INSERT LOCK NUT, GRADE 2, ZINC FINISH, 5/16"-18	2
8	33454	NARROW MACHINERY BUSHING, PLAIN FINISH, 1 3/4" X 18 GA	8
9	01-118-001	BOLT, CYLINDER RETAINING	3
10	25-112-004	PIN, CYLINDER PIVOT	1
11	05-112-301	PIN, AXLE	2
12	99-115-001	WASHER, THRUST	2
13	26335	SHOULDER SCREW, GRADE 2, 0.375x2" LG	2
15	36310	1/2"-13 UNC GR. 5 HEX NUT Z PLATED	3
17	24-537-001	WELDMENT MAINTENANCE PROP	2

*Representative BoM. Details vary by specific model. Contact the factory for details regarding your specific Table.*

**6-½ HP External Power Unit Assembly – 6.5 HP, 3 PH (99-660-177).**

Representative diagram of major components. Contact the factory for replacement parts for your specific model. ALWAYS have the product serial number or model number on hand when calling the factory.

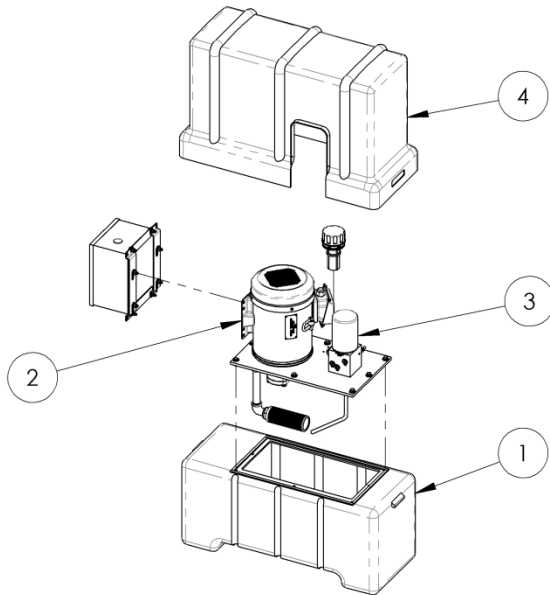

ITEM	PART NO.	DESCRIPTION	QTY
1	99-523-108-1101	ASSEMBLY, RESERVOIR, 32 x 13 x 14	1
2	99-135-035	AC MOTOR 3Ø 60/50 Hz 6.5 HP	1
3	05-627-012	ASSEMBLY, MANIFOLD	1
4	22-024-003	COVER, POWER UNIT	1
5	99-522-025	ASSEMBLY, HAND CONTROL (2- BUTTON) (NOT DEPICTED)	1
6	05-623-003	ASSEMBLY, HOSE, POWER UNIT Ø1/2" x 96" LONG (NOT DEPICTED)	1

**Motor/Pump, 460 V, 6.5 HP, 3Ø, 1750 RPM, 0.512 DISP. (99-137-035-004).**

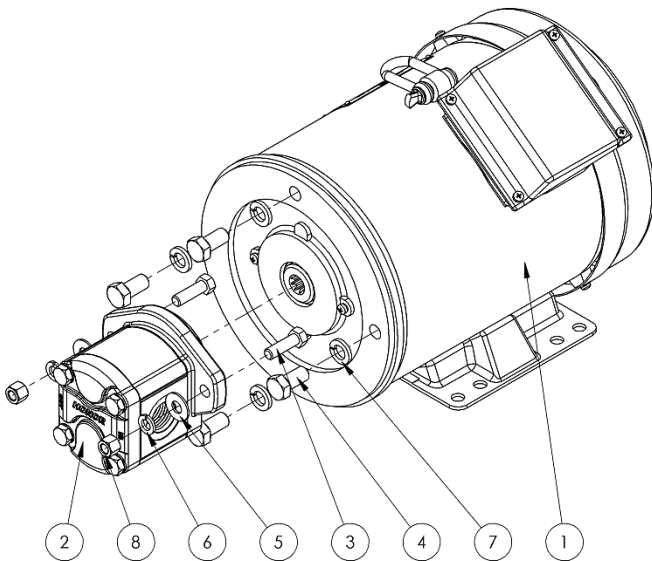

ITEM	PART NO.	DESCRIPTION	QTY
1	99-135-036	AC MOTOR, 3Ø, 460V, 60/50 Hz, (208-230-190V / 460-380V), 1725/1440 RPM, 1.15SF, 184T, TEFC	1
2	05-143-005	PUMP, HYDRAULIC GEAR	1
3	11107	HEX BOLT, GRADE A, ZINC FINISH, 3/8-16 UNC x 1-1/4"	2
4	11205	HEX BOLT, GRADE A, ZINC FINISH, 1/2-13 UNC x 1-1/4"	4
5	33008	FLAT WASHER, USS, ZINC PLATED, 3/8"	2
6	33622	SPLIT LOCK WASHER, ZINC FINISH, 3/8"	2
7	33626	LOCK WASHER, ZINC FINISH, 1/2"	4
8	37024	NYLON INSERT LOCK NUT, GRADE 2, ZINC FINISH, 3/8-16 UNC	2

**Manifold Assembly (05-627-012)**

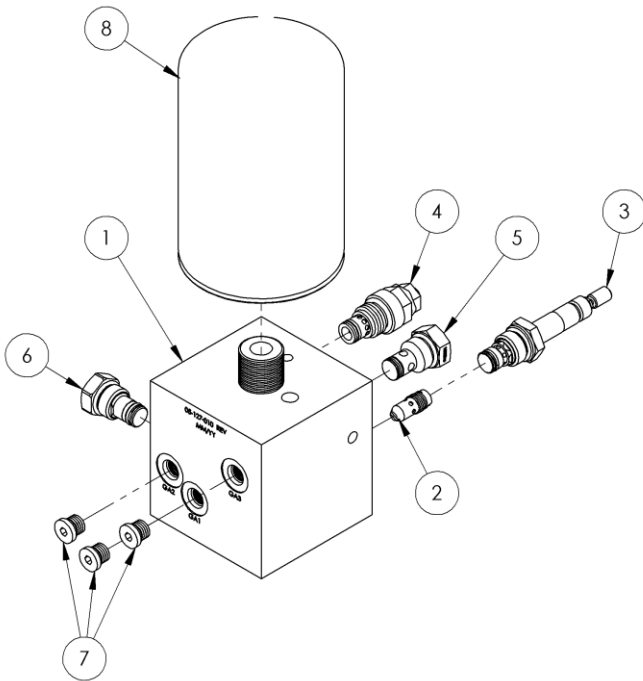

ITEM	PART NO.	DESCRIPTION	QTY
1	05-127-010	MANIFOLD, HYDRAULIC	1
2	99-153-041-001	FLOW CONTROL, PRES. COMP., 3.2 GAL	1
3	99-153-016	VALVE, CARTRIDGE, N.C. W/ MANUAL OVERRIDE, SIZE 08	1
4	99-153-006	VALVE, PRESSURE RELIEF, 210 BAR	1
5	99-153-068	VALVE, CHECK, NOSE-IN/SIDE-OUT, 25 PSI	1
6	99-153-011	CHECK VALVE, SIZE 08, NOSE-IN/ SIDE-OUT	1
7	99-116-005	FITTING, HYDRAULIC, 04MORB HOLLOW HEX PLUG	3
8	22-031-007	RESERVOIR, FILTER, HYDRAULIC, SPIN-ON, 1"-12 THREAD, 10 MICRON	1

**Manifold Hydraulic Diagram (05-627-012)**

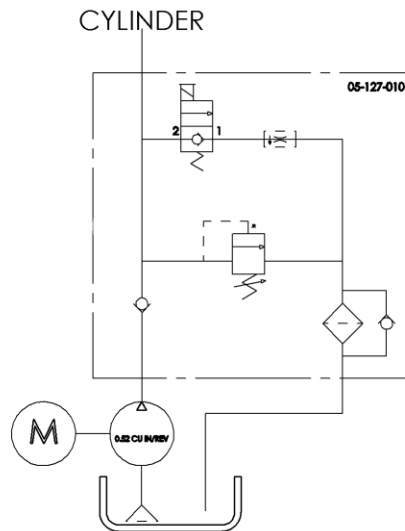

## LIMITED WARRANTY

Vestil Manufacturing Company ("Vestil") warrants this product to be free of defects in material and workmanship during the warranty period. Our warranty obligation is to provide a replacement for a defective, original part covered by the warranty after we receive a proper request from the Warrantee (you) for warranty service.

### Who may request service?

Only a warrantee may request service. You are a warrantee if you purchased the product from Vestil or from an authorized distributor AND Vestil has been fully paid.

### Definition of "original part"?

An original part is a part used to make the product as shipped to the Warrantee.

### What is a "proper request"?

A request for warranty service is proper if Vestil receives: 1) a photocopy of the Customer Invoice that displays the shipping date; AND 2) a written request for warranty service including your name and phone number. Send requests by one of the following methods:

#### US Mail

Vestil Manufacturing Company  
2999 North Wayne Street, PO Box 507  
Angola, IN 46703

#### Fax

(260) 665-1339  
Phone  
(260) 665-7586

#### Email

[info@vestil.com](mailto:info@vestil.com)

Enter "Warranty service request" in subject field

In the written request, list the parts believed to be defective and include the address where replacements should be delivered. After Vestil receives your request for warranty service, an authorized representative will contact you to determine whether your claim is covered by the warranty. Before providing warranty service, Vestil will require you to send the entire product, or just the defective part (or parts), to its facility in Angola, IN.

### What is covered under the warranty?

The warranty covers defects in the following original, dynamic parts: motors, hydraulic pumps, motor controllers, and cylinders. It also covers defects in original parts that wear under normal usage conditions ("wearing parts"), such as bearings, hoses, wheels, seals, brushes, and batteries.

### How long is the warranty period?

The warranty period for original dynamic components is 1 year. For wearing parts, the warranty period is 90 days. Both warranty periods begin on the date Vestil ships the product to the Warrantee. If the product was purchased from an authorized distributor, the periods begin when the distributor ships the product. Vestil may, at its sole discretion, extend a warranty period for products shipped from authorized distributors by up to 30 days to account for shipping time.

### If a defective part is covered by the warranty, what will Vestil do to correct the problem?

Vestil will provide an appropriate replacement for any covered part. An authorized representative of Vestil will contact you to discuss your claim.

### What is not covered by the warranty?

The Warrantee (you) are responsible for paying labor costs and freight costs to return the product to Vestil for warranty service.

### Events that automatically void this Limited Warranty.

- Misuse;
- Negligent assembly, installation, operation or repair;
- Installation/use in corrosive environments;
- Inadequate or improper maintenance;
- Damage sustained during shipping;
- Collisions or other accidents that damage the product;
- Unapproved modifications: Do not modify the product IN ANY WAY without first receiving written authorization from Vestil.

### Do any other warranties apply to the product?

Vestil Manufacturing Company makes no other express warranties. All implied warranties are disclaimed to the extent allowed by law. Any implied warranty not disclaimed is limited in scope to the terms of this Limited Warranty. Vestil makes no warranty or representation that this product complies with any state or local design, performance, or safety code or standard. Noncompliance with any such code or standard is not a defect in material or workmanship.

