

DJ1049

Assembly Instruction

Installation Video QR



SKU:DJ1049WTBR-216CM
<https://vimeo.com/1105382252>

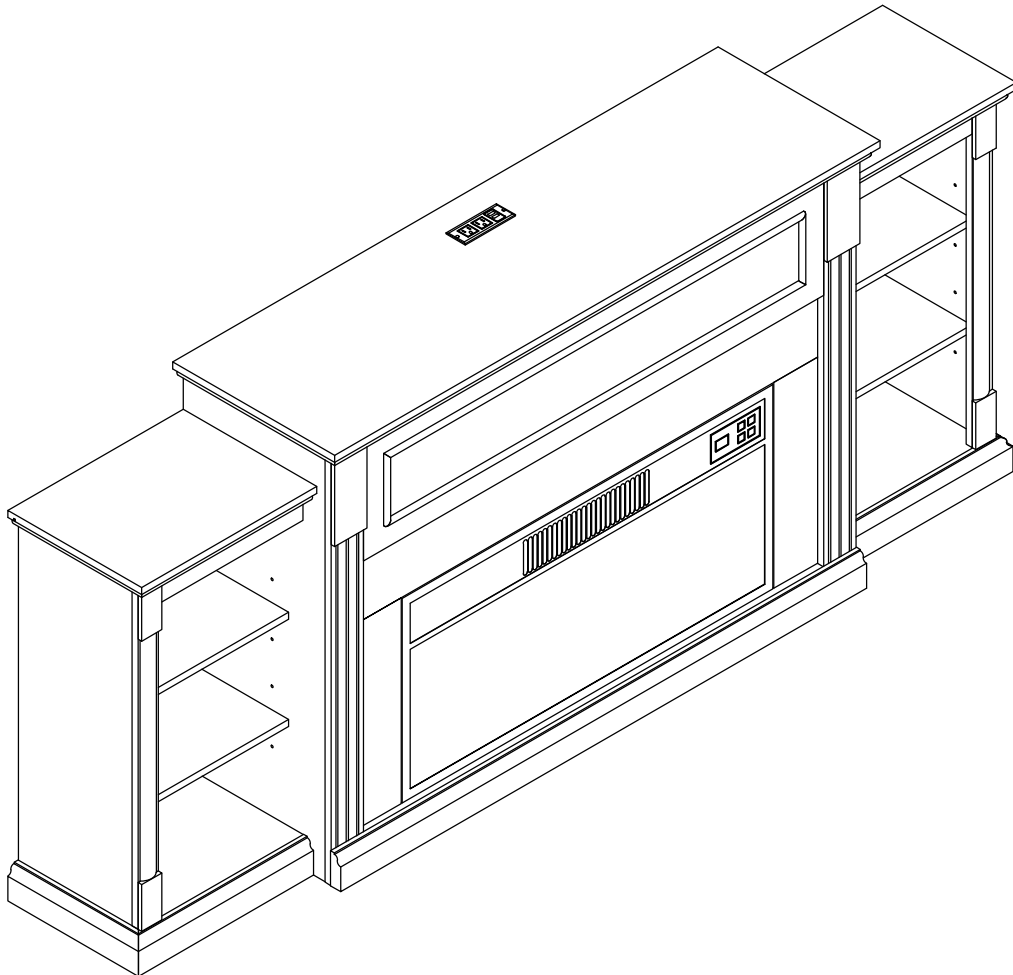

SAFETY TIPS:

Static charge may cause dust on foam- clean with a dry or damp cloth. Small foam strands may be present - handle gently and dispose of properly. Do not burn or incinerate. Check local recycling guidelines.

Installation Video QR



DJ1049
<https://vimeo.com/1105382252>

Version No.: DJ1049

Note: If you encounter any issues, please contact customer service.

Explosion Diagram

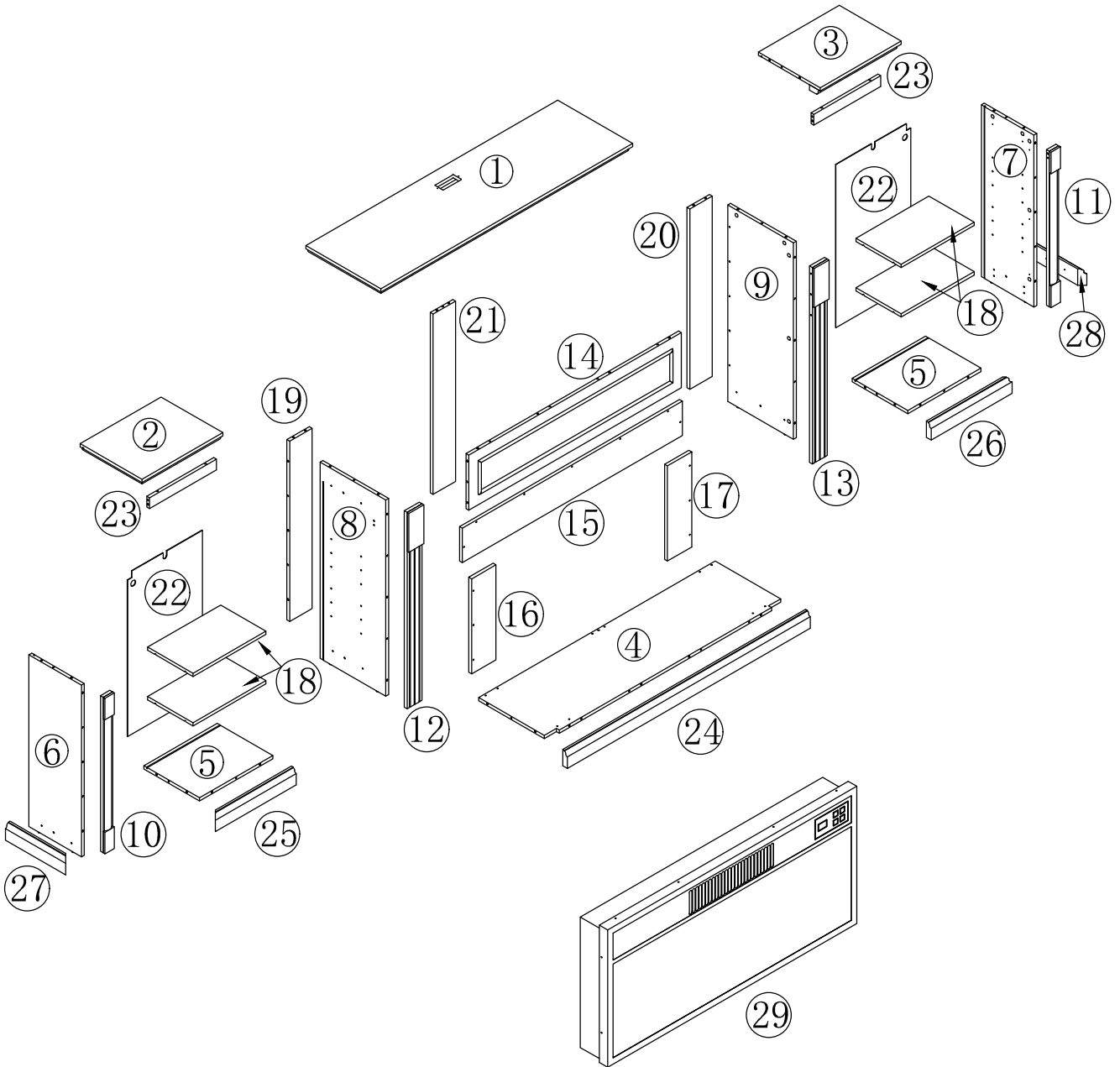

Note: If you encounter any issues, please contact customer service.

Parts and Operation Elements

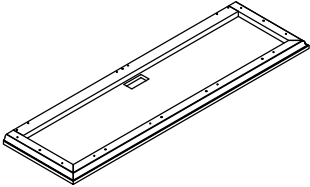
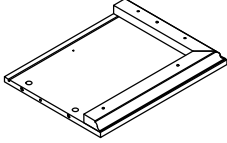
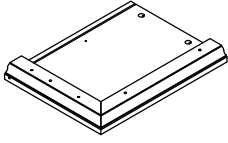
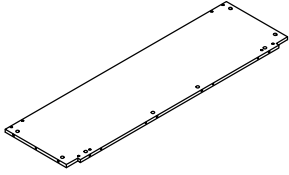
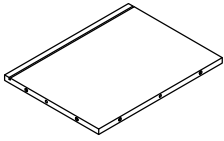
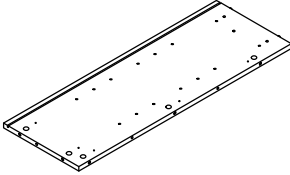
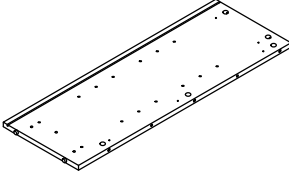
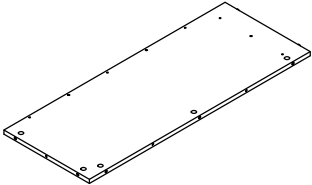
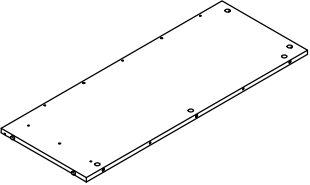
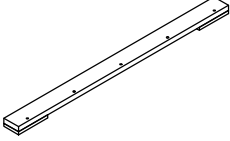
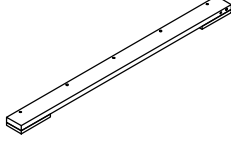
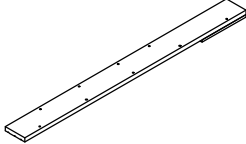
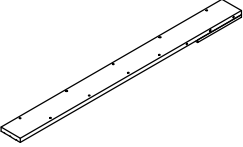
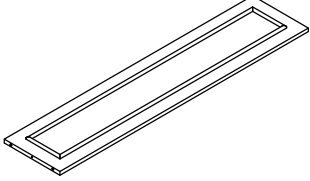
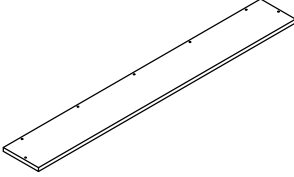
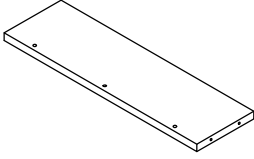
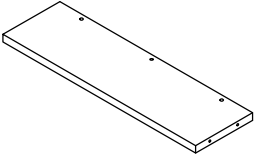
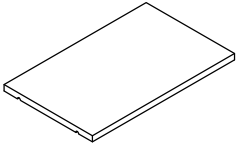
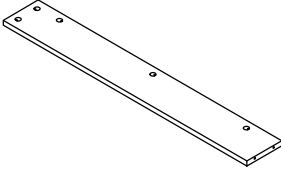
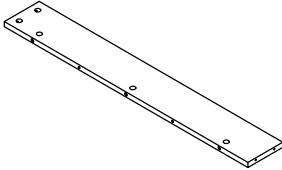
			
① 1PC	② 1PC	③ 1PC	④ 1PC
			
⑤ 2PCS	⑥ 1PC	⑦ 1PC	⑧ 1PC
			
⑨ 1PC	⑩ 1PC	⑪ 1PC	⑫ 1PC
			
⑬ 1PC	⑭ 1PC	⑮ 1PC	⑯ 1PC
			
⑰ 1PC	⑱ 4PCS	⑲ 1PC	⑳ 1PC





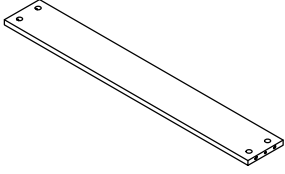
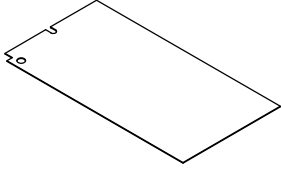
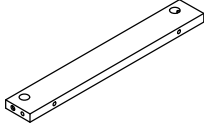
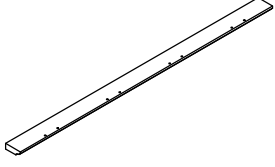
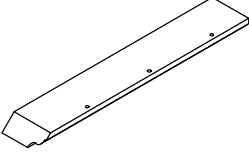
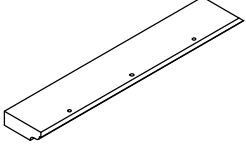
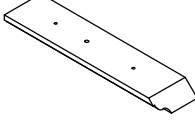
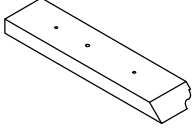
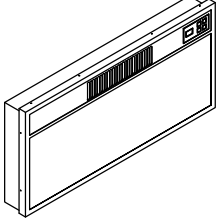





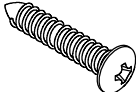
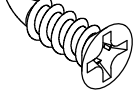
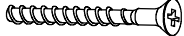
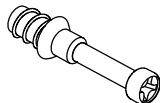

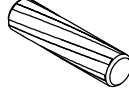

Note: If you encounter any issues, please contact customer service.

Parts and Operation Elements

			
②① 1PC	②② 2PCS	②③ 2PCS	②④ 1PC
			
②⑤ 1PC	②⑥ 1PC	②⑦ 1PC	②⑧ 1PC
			
②⑨ 1PC			

Note: If you encounter any issues, please contact customer service.

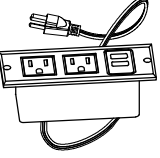
HardWare

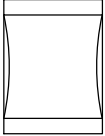
<h1>HardWare</h1>			
 M5*25mm		 M3*12mm	
 M5*40mm		 Cam Bolt	
A	13PCS +2PCS	B	2PCS
 Ø15*9mm Cam Lock		 Ø6*30mm	
 (G1)*2		 (G2)*2 M4*40mm	
 (G3)*2		 (G4)*2 M3.5*12mm	
 Ø5*20mm			
E	70PCS +2PCS	F	48PCS +2PCS
 Ø25mm		 (J1)*10	
 (J2)*10 M2.6*8mm		 (K1)*12 M3*16mm	
 (K2)*12			
I	70SETS +2PCS	J	10PCS +2PCS
		 (N1)*1	
 (N2)*1		 SPARE BAG	
M	1PC	N	



Tips: The number after "+" represents the spare hardware.

Note: If you encounter any issues, please contact customer service.

1

Before assembly, please lay out all the panels and hardware in order. Take only what is needed to prevent losing any parts and to facilitate the installation!

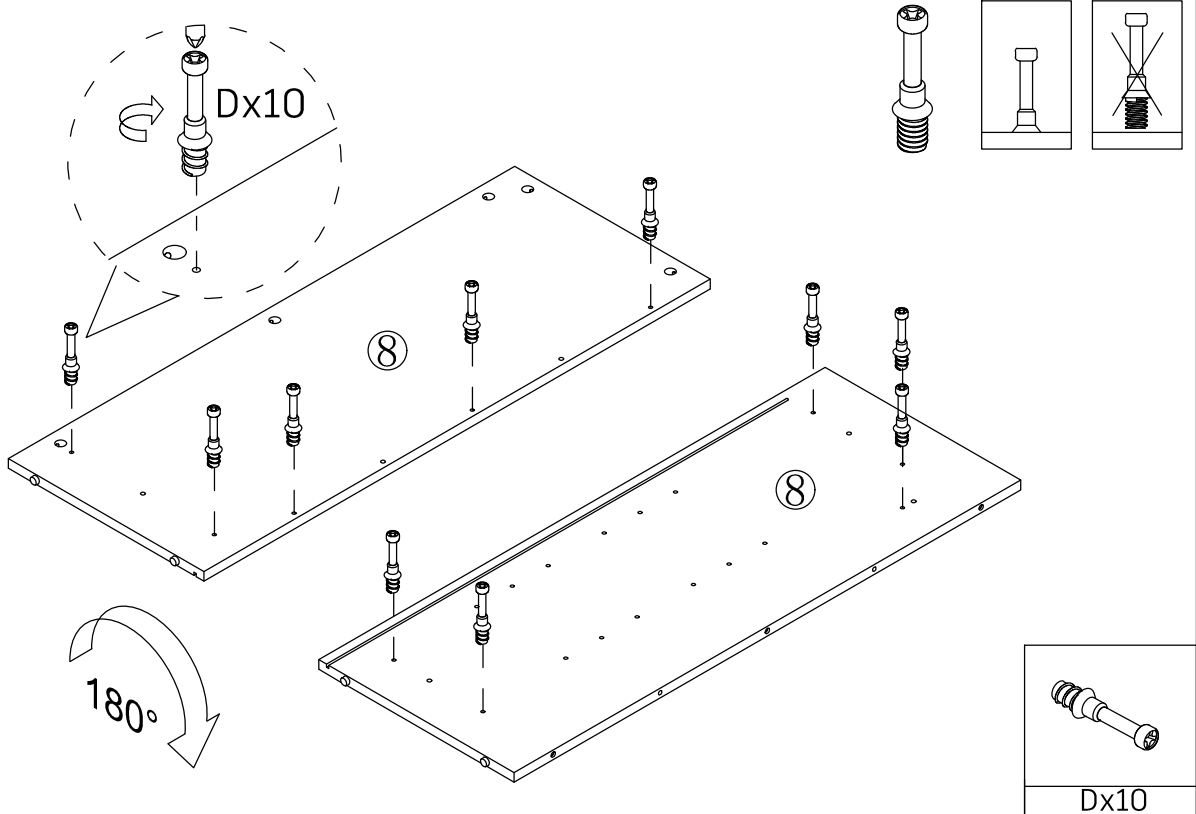

2

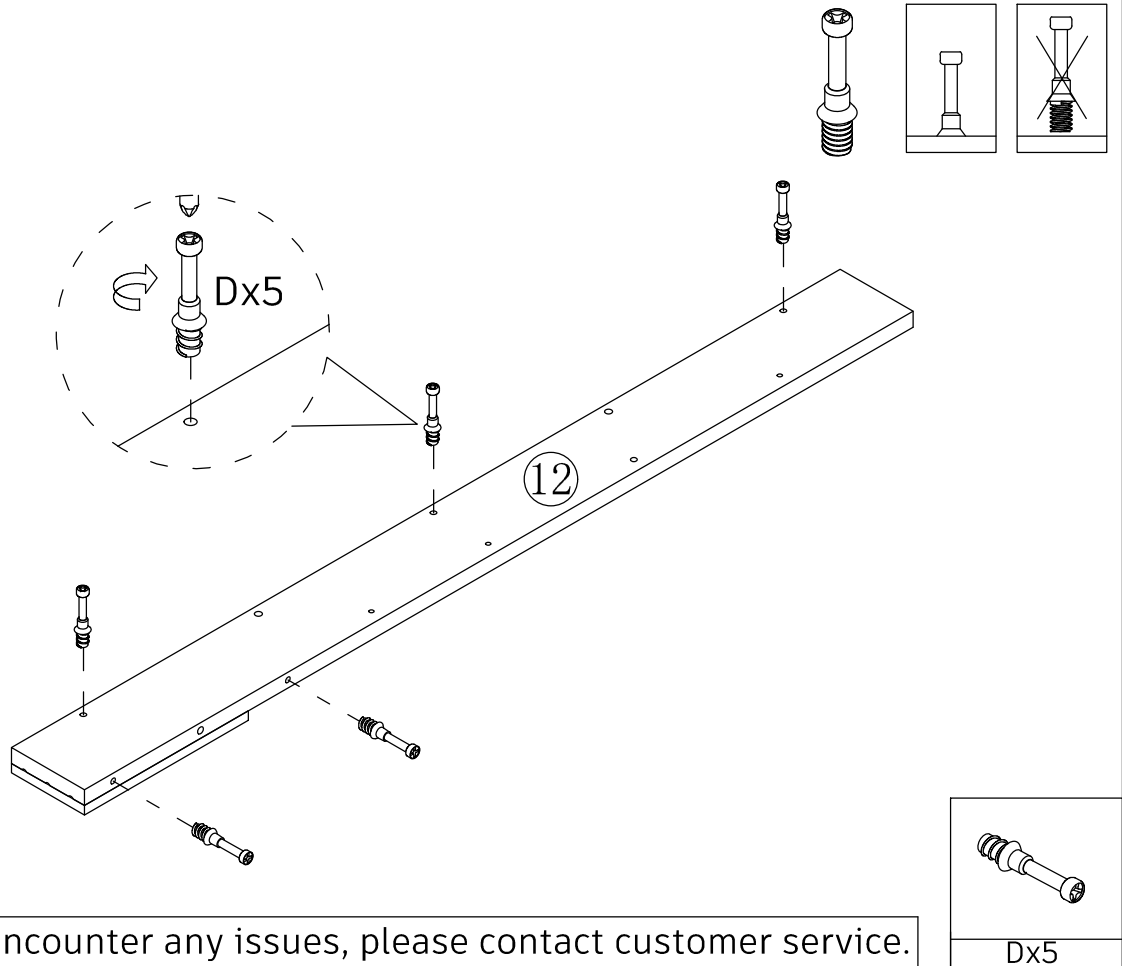

Note: If you encounter any issues, please contact customer service.

3

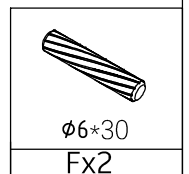
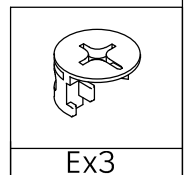
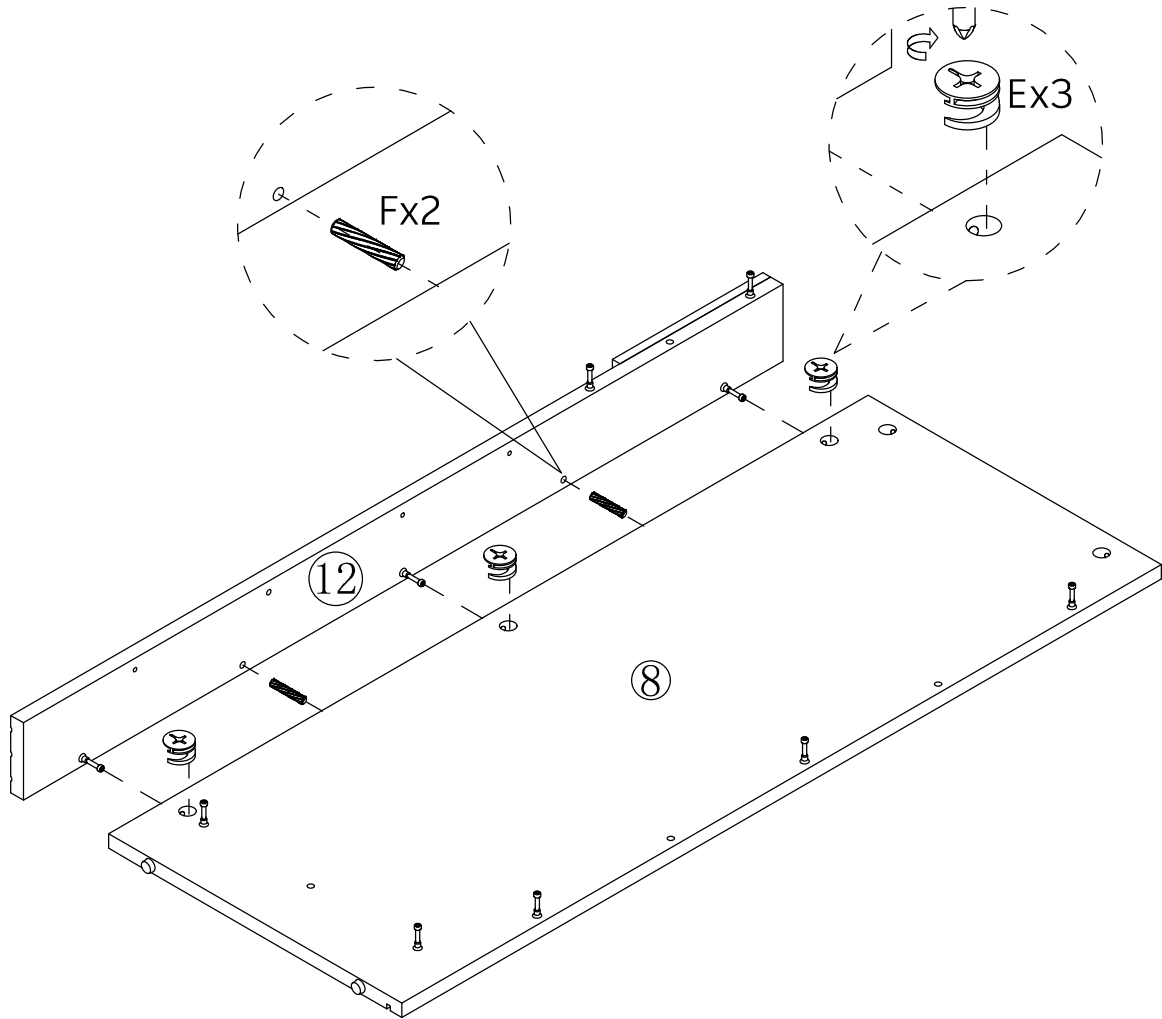
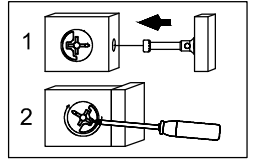
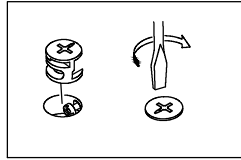
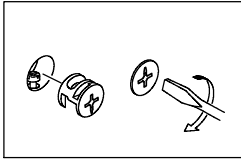

Note: If you encounter any issues, please contact customer service.

4

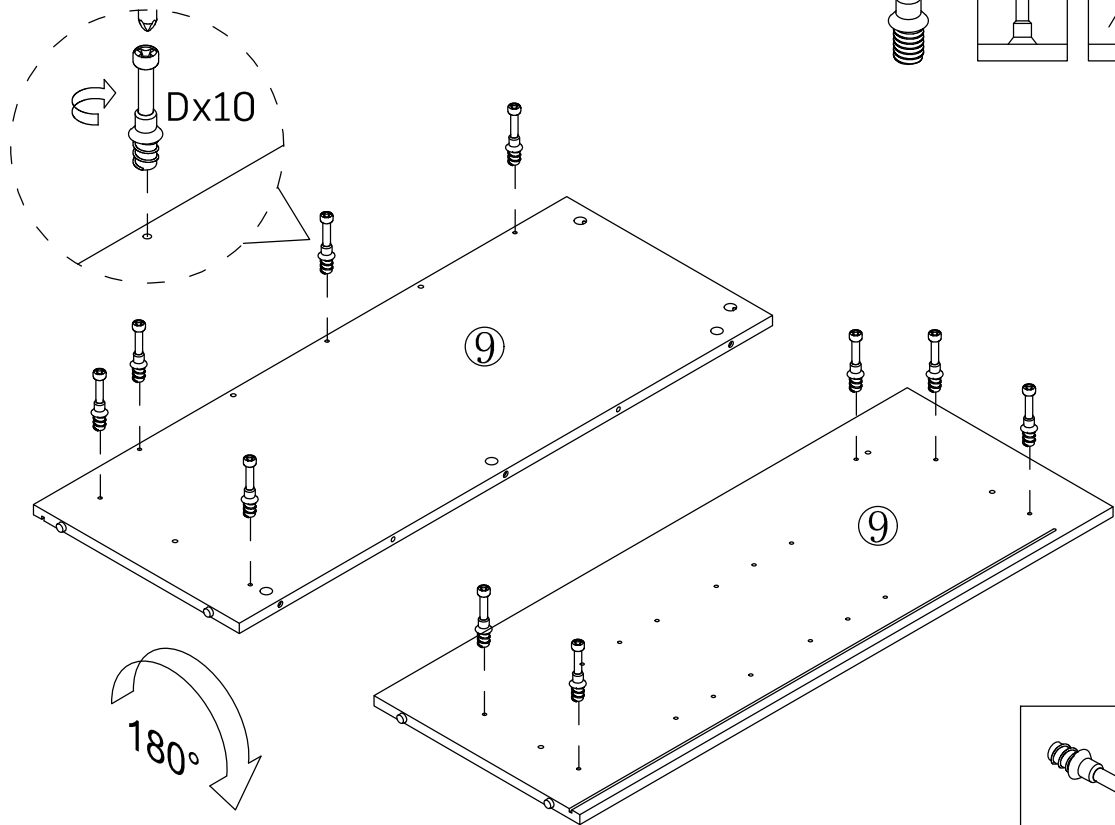

Dx10

5

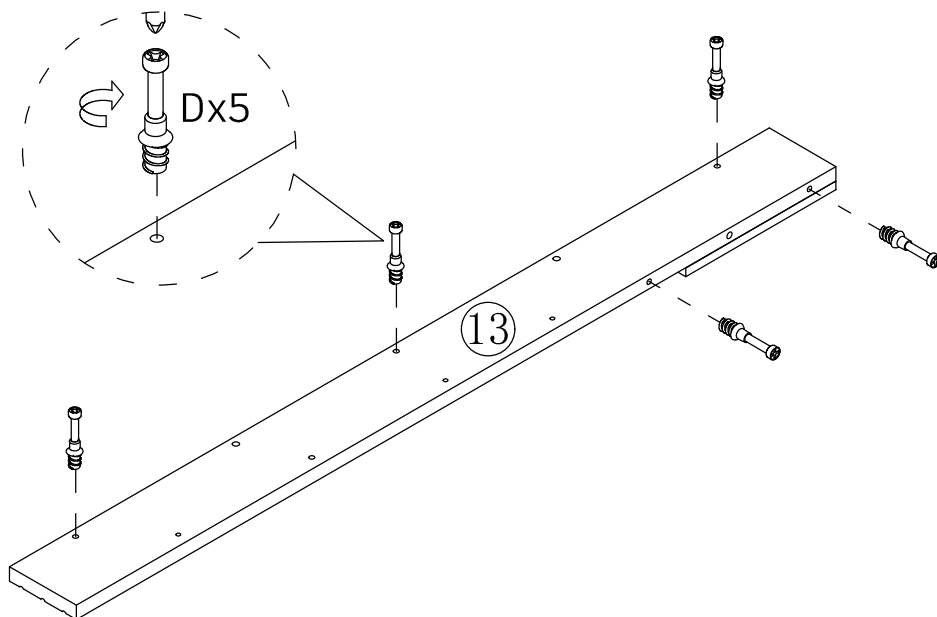

Dx5

Note: If you encounter any issues, please contact customer service.

6

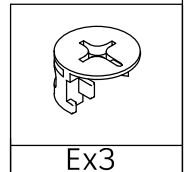
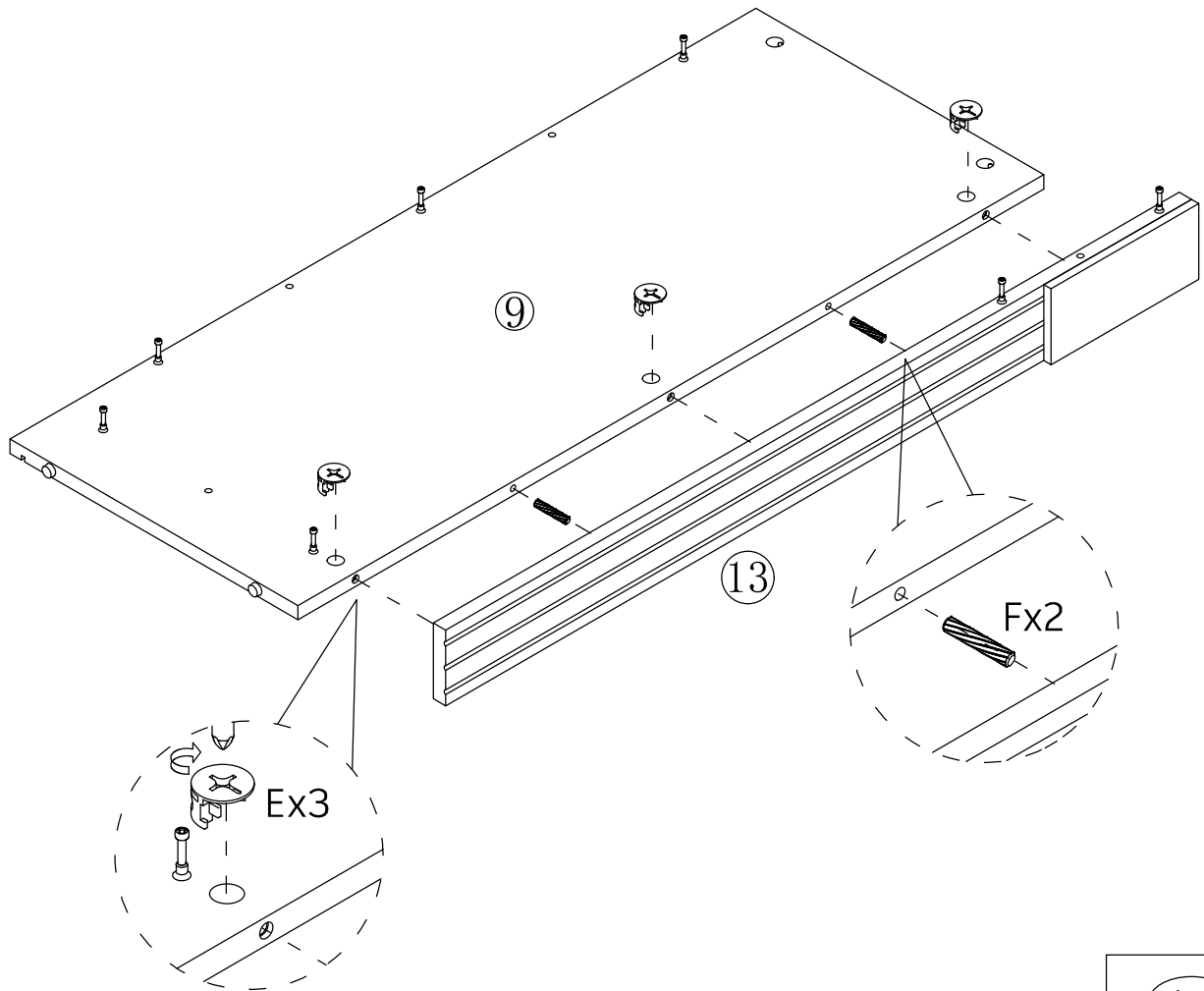
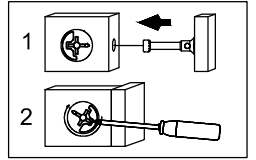
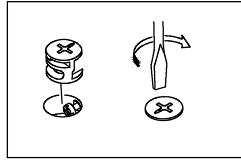
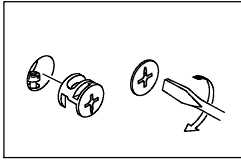

Ex3

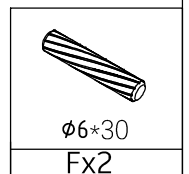

φ6*30
Fx2

Note: If you encounter any issues, please contact customer service.

7

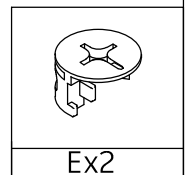
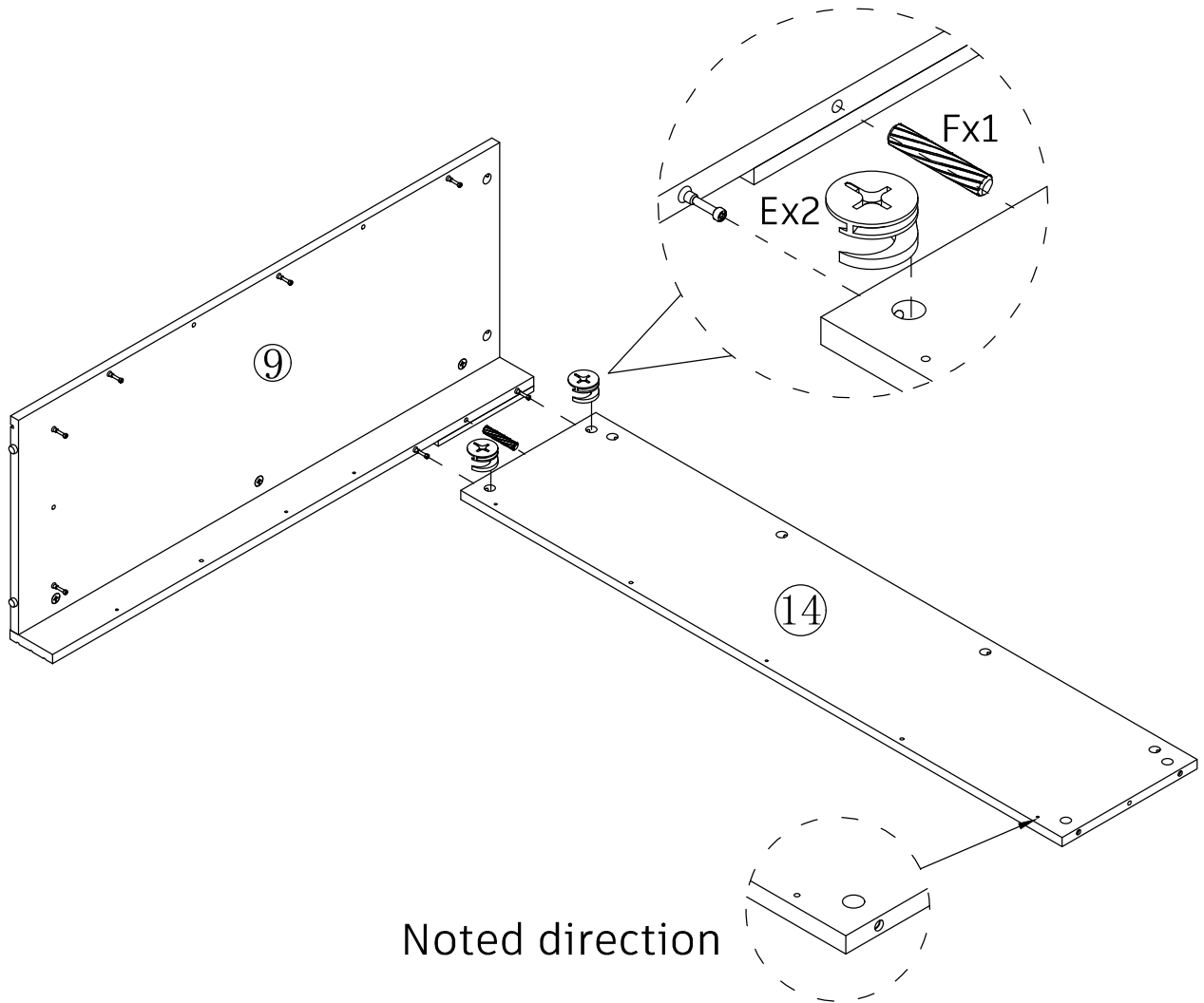
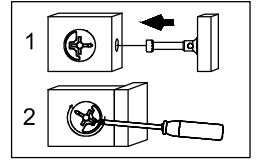
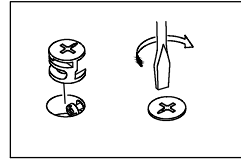
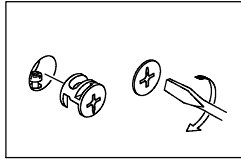

Ex2

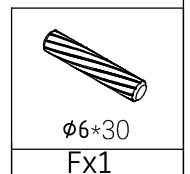

φ6*30
Fx1

Note: If you encounter any issues, please contact customer service.

8

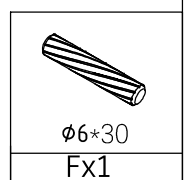
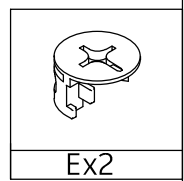
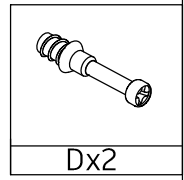
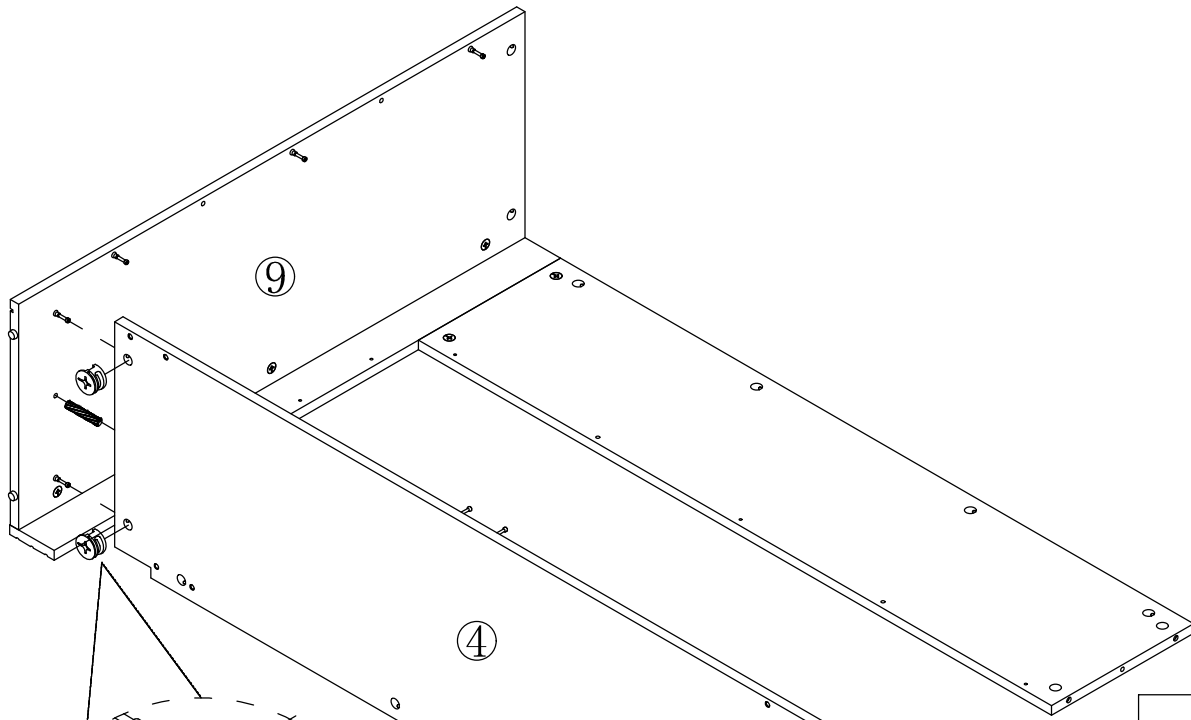
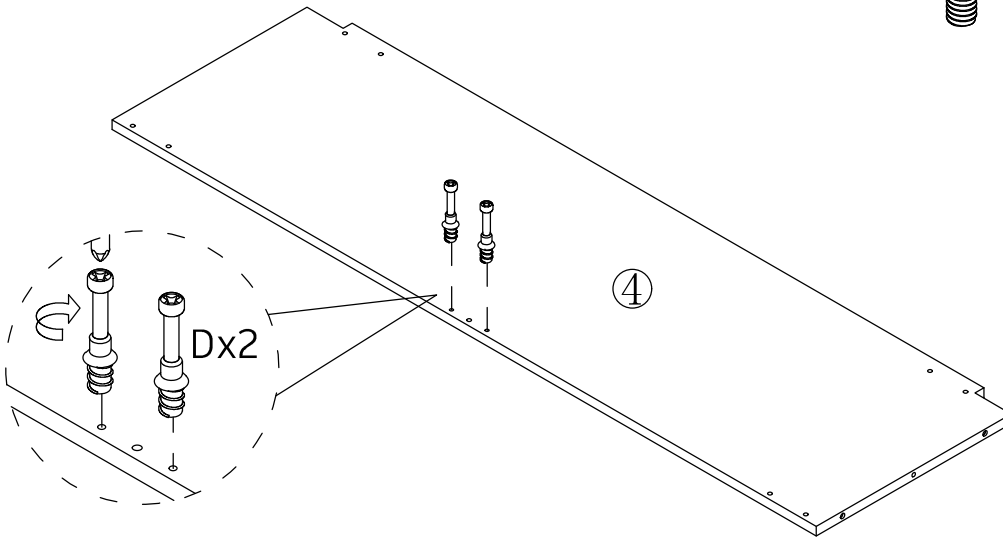
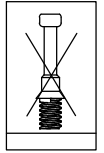
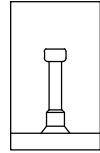

Note: If you encounter any issues, please contact customer service.

9

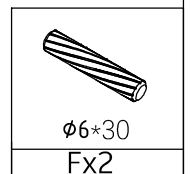
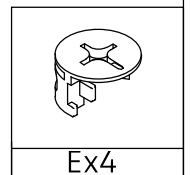
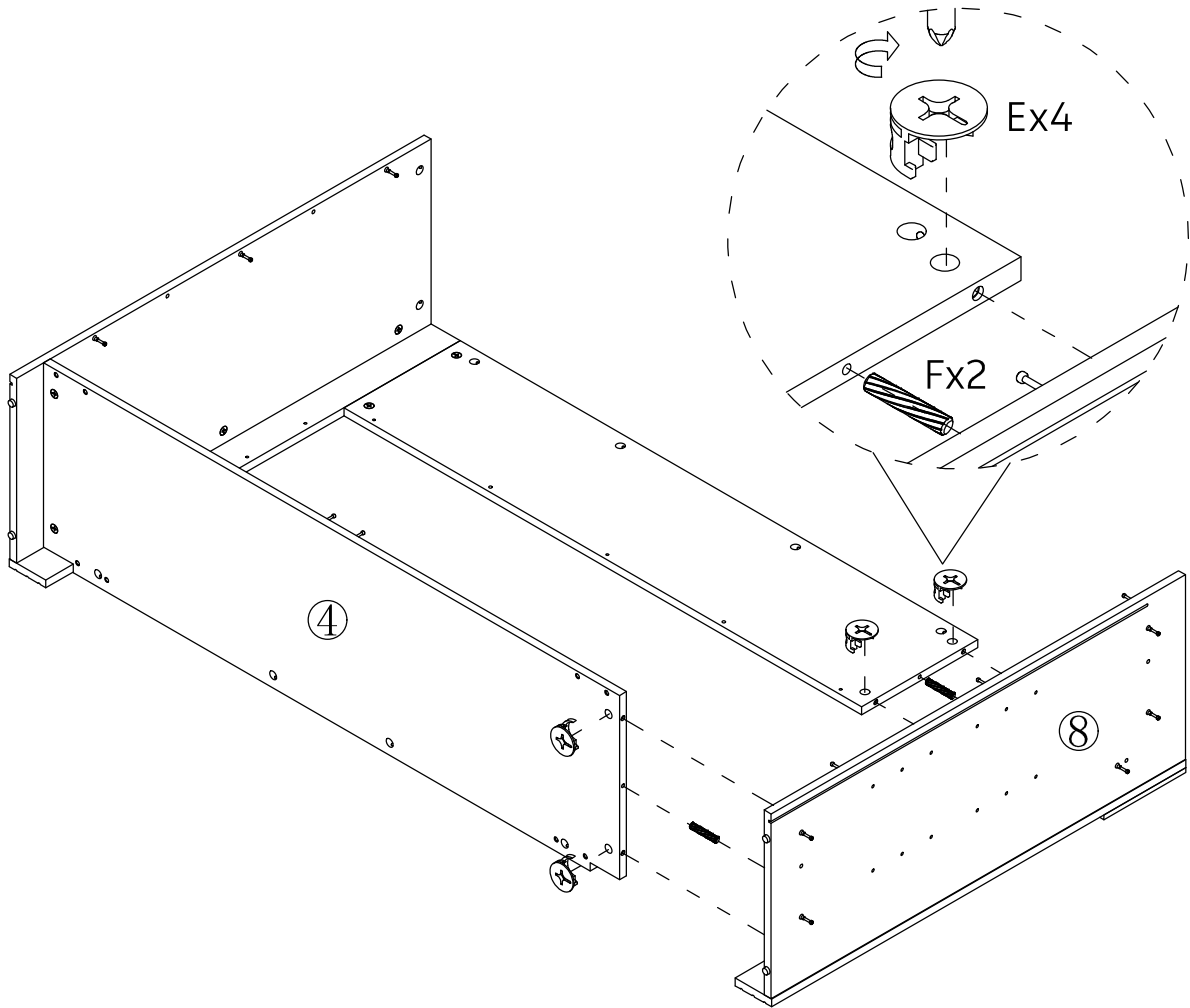
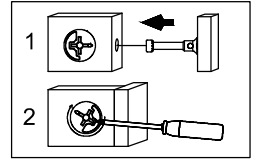
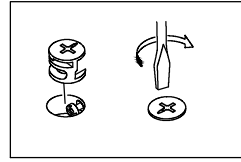
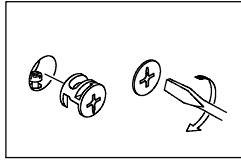

Note: If you encounter any issues, please contact customer service.

10

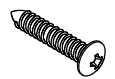
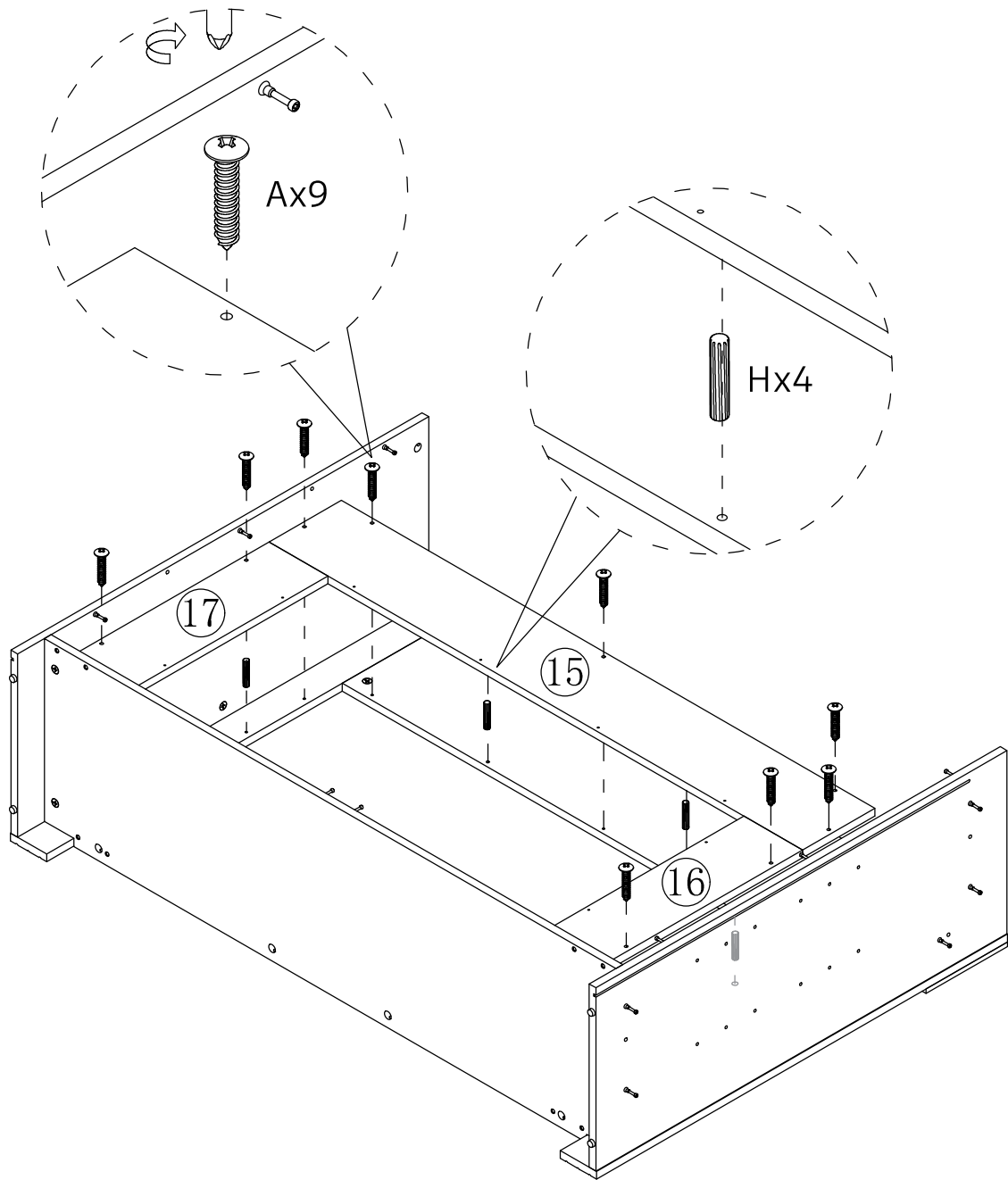

M5*25
Ax9

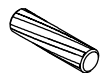

φ5*20
Hx4

Note: If you encounter any issues, please contact customer service.

11

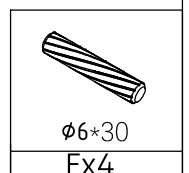
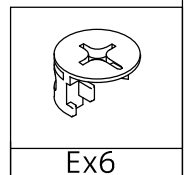
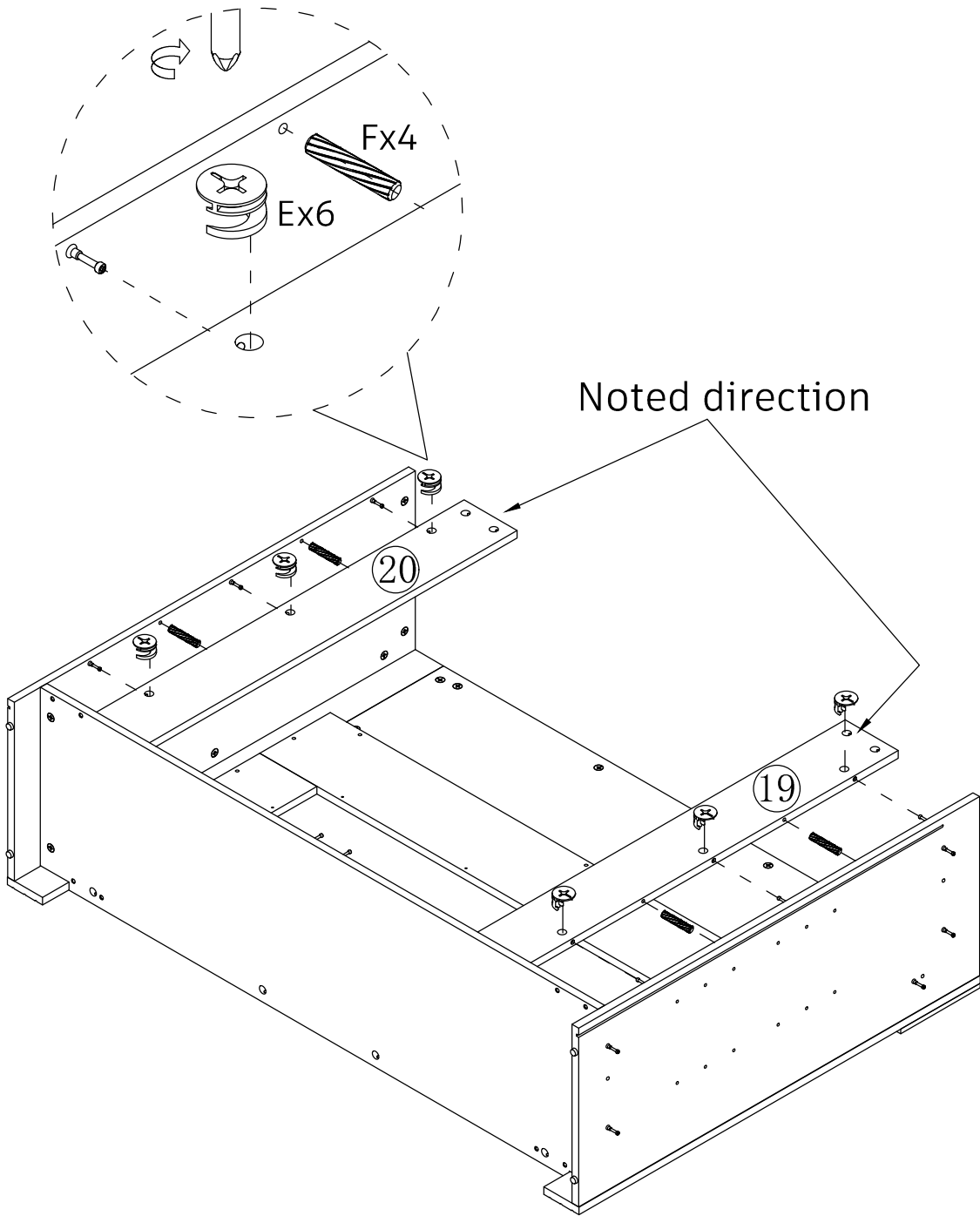

Note: If you encounter any issues, please contact customer service.

12

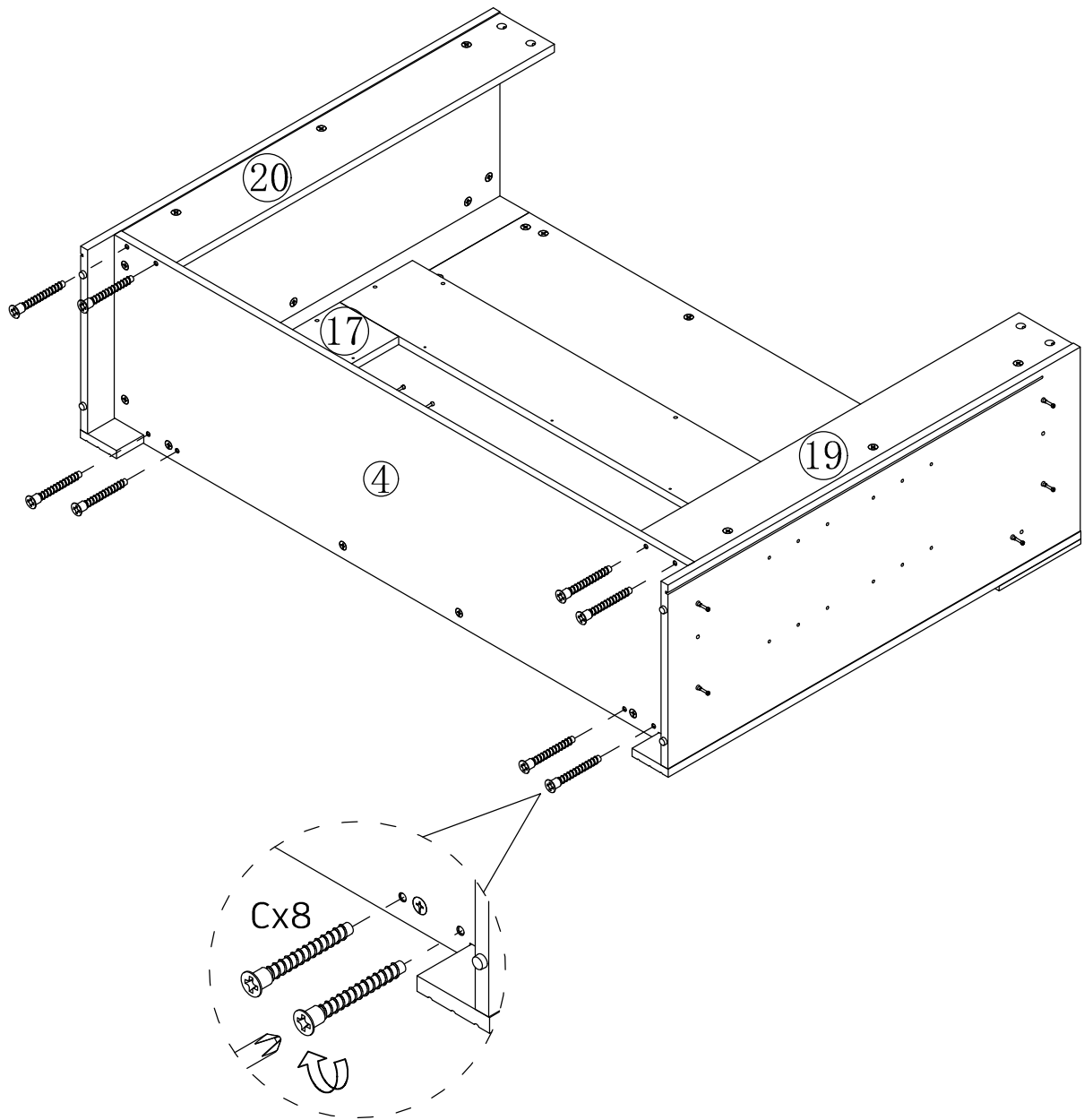

Note: If you encounter any issues, please contact customer service.

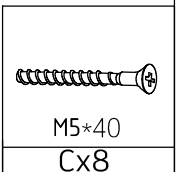

13

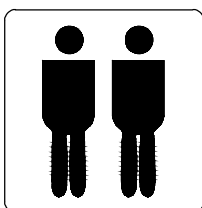
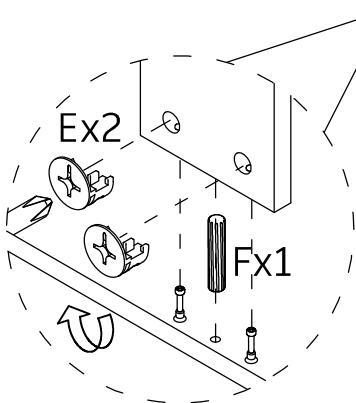
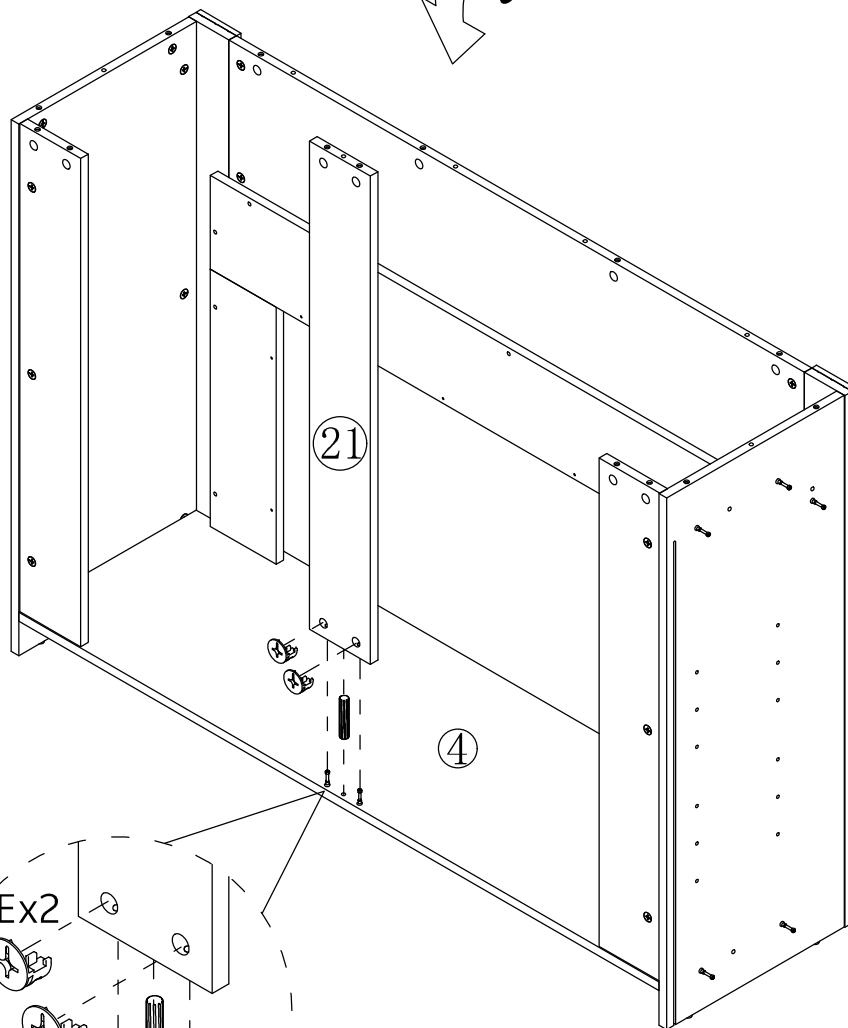
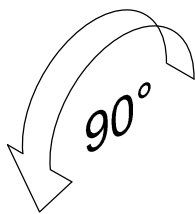
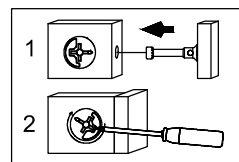
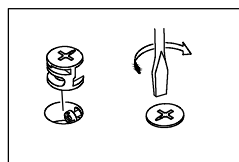
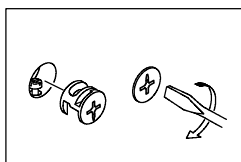

This step require two people to be completed.

Note: If you encounter any issues, please contact customer service.

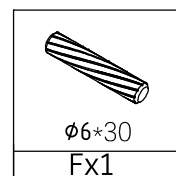
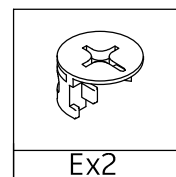

14

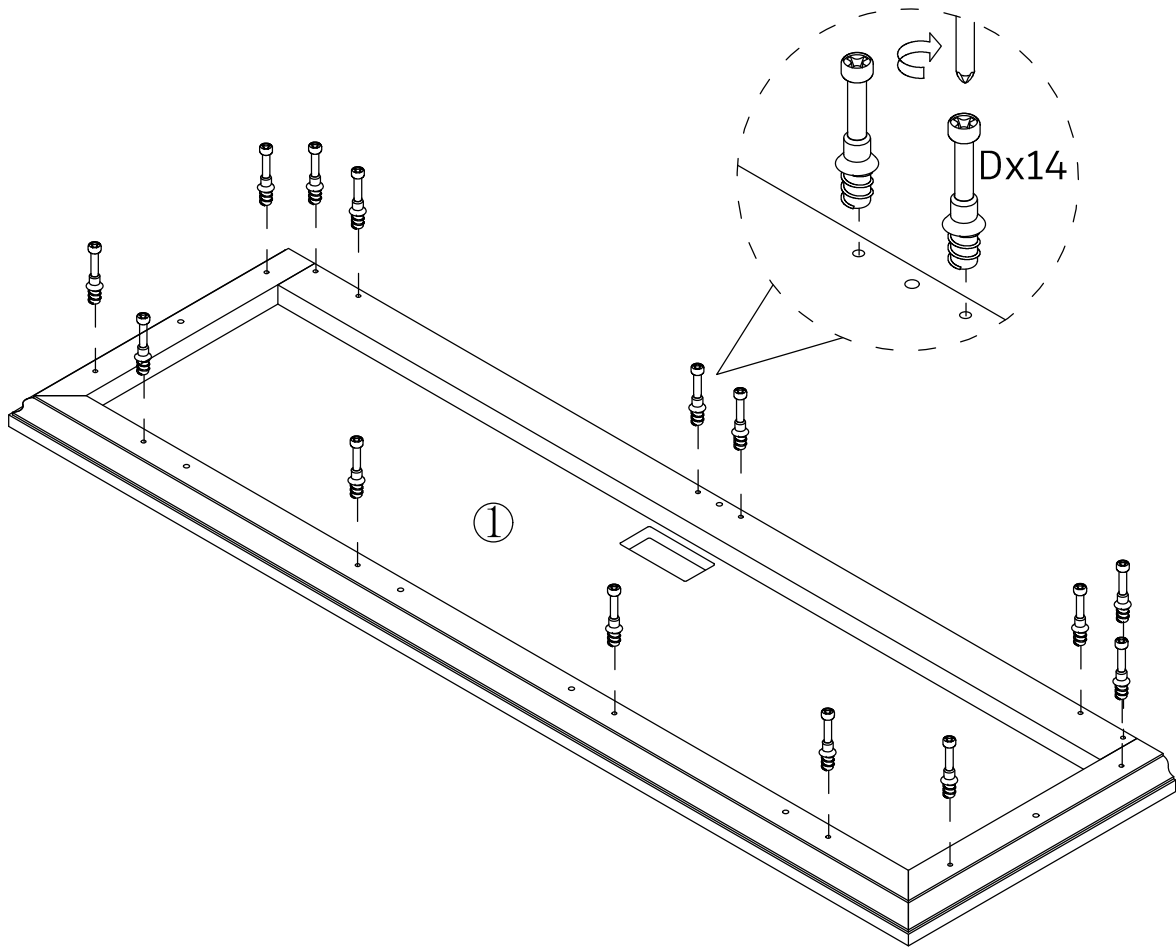
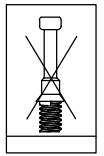
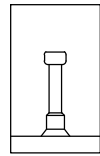

Note: If you encounter any issues, please contact customer service.

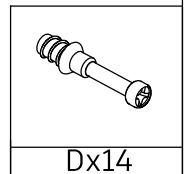

15

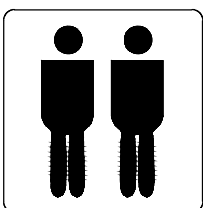
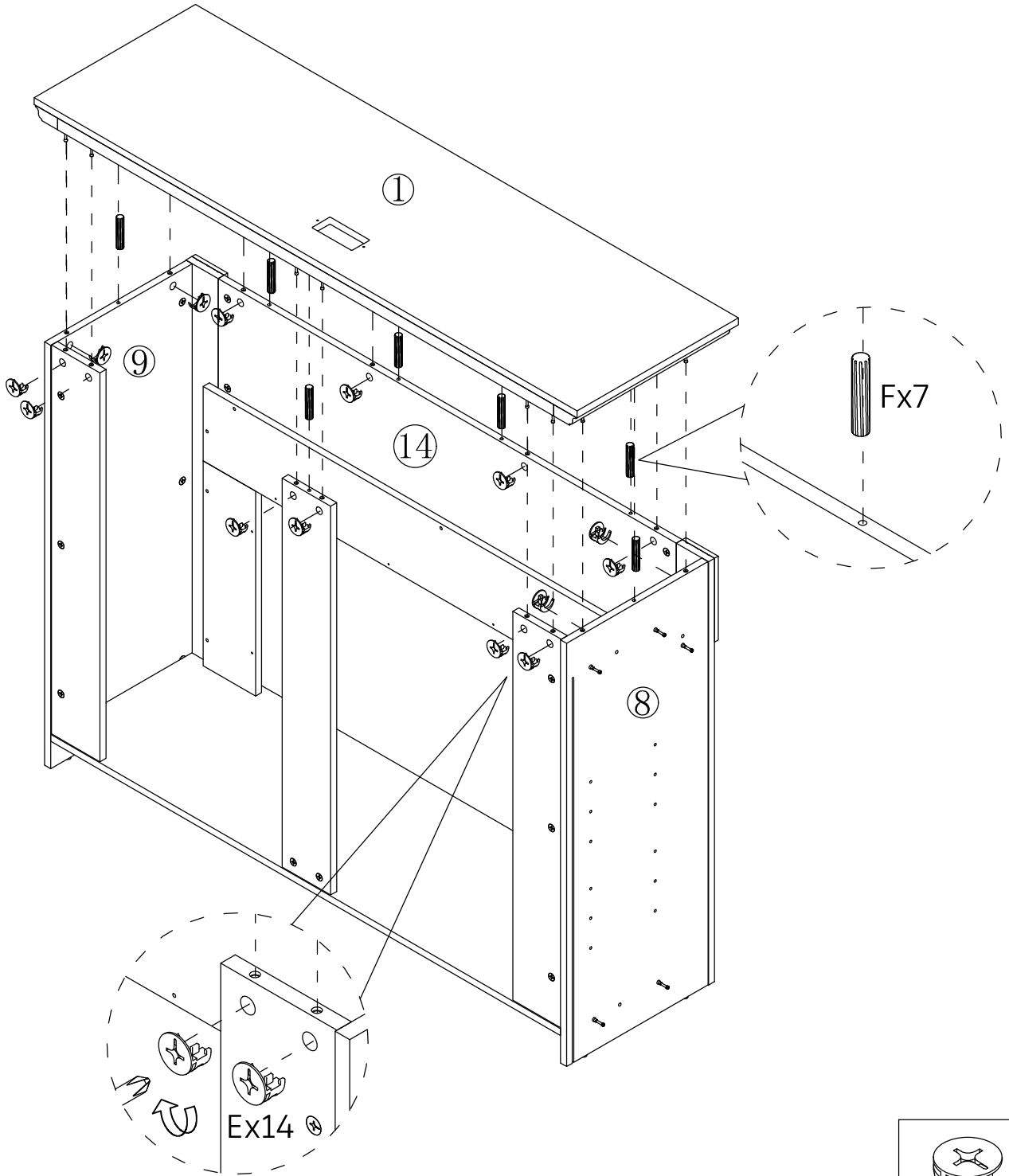
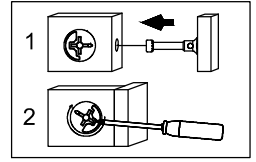
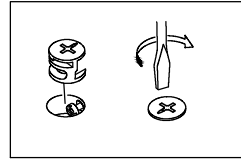
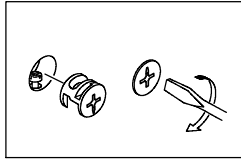

This step require two people to be completed.

Note: If you encounter any issues, please contact customer service.

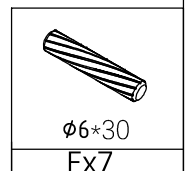
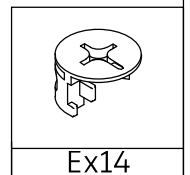

16

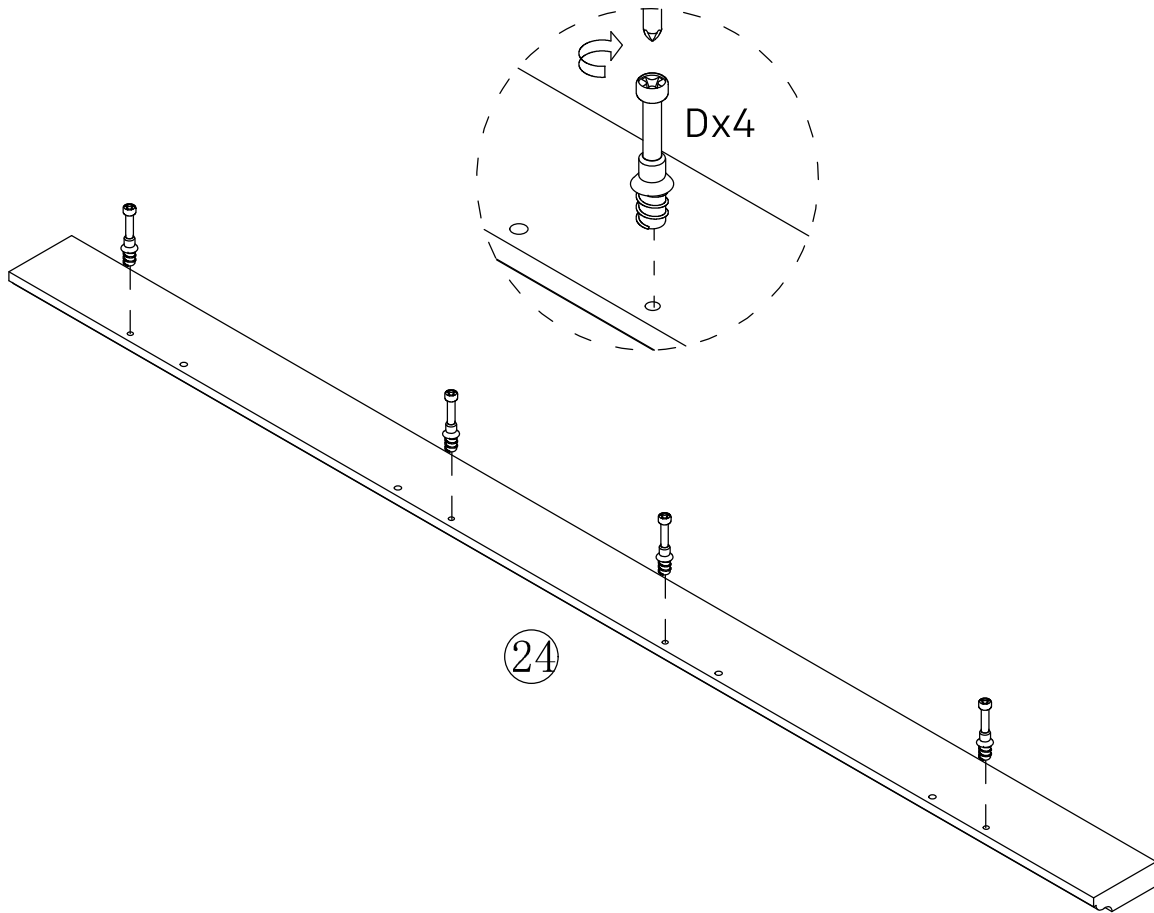
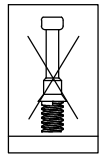
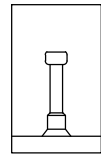

Note: If you encounter any issues, please contact customer service.

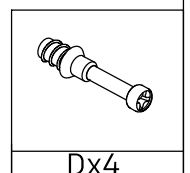

Dx4

17

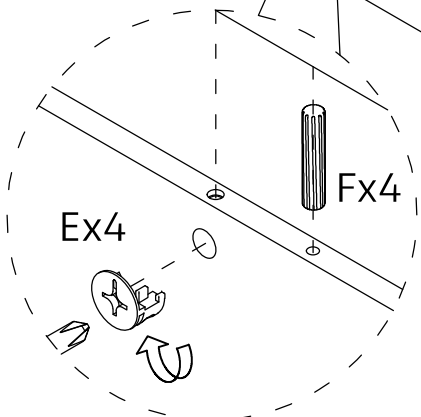
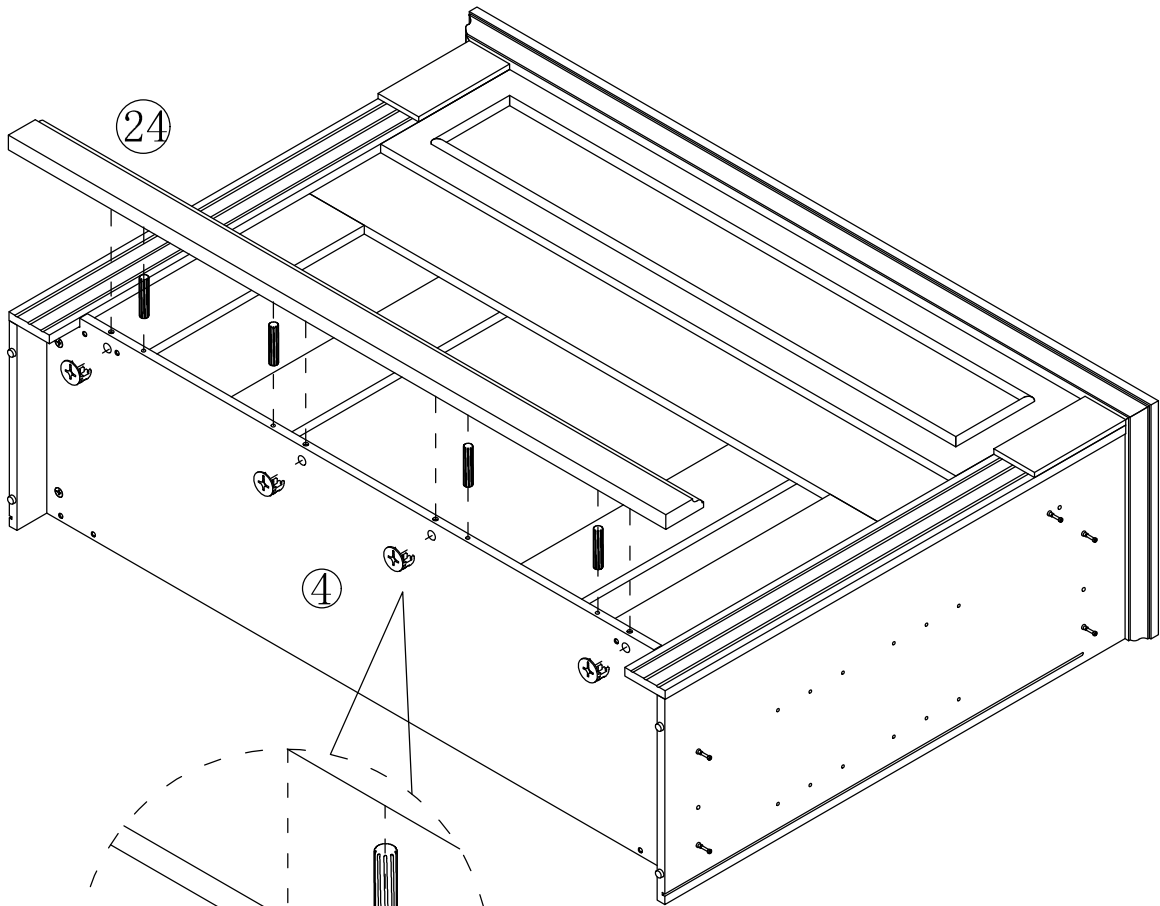
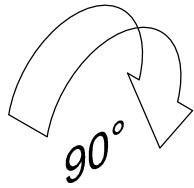
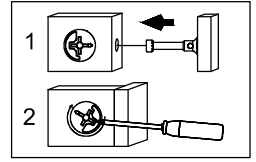
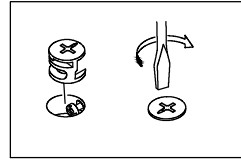
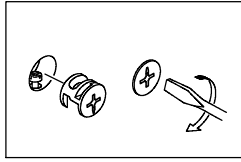

This step require two people to be completed.

Note: If you encounter any issues, please contact customer service.

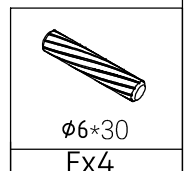
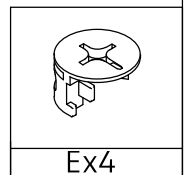

18

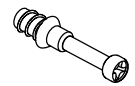
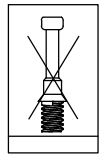
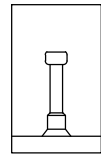
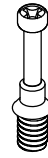
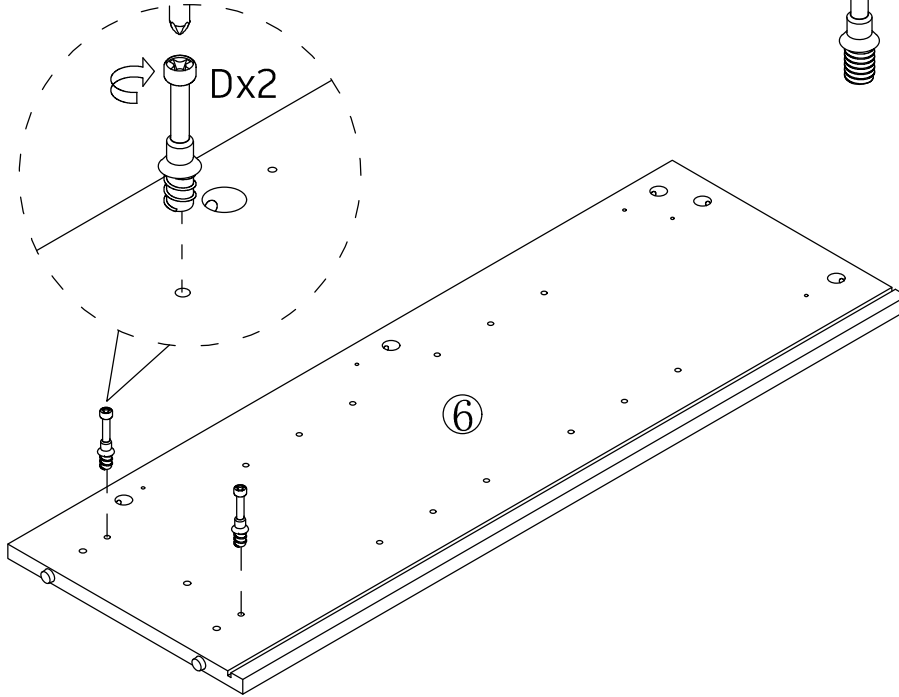

Dx2

19

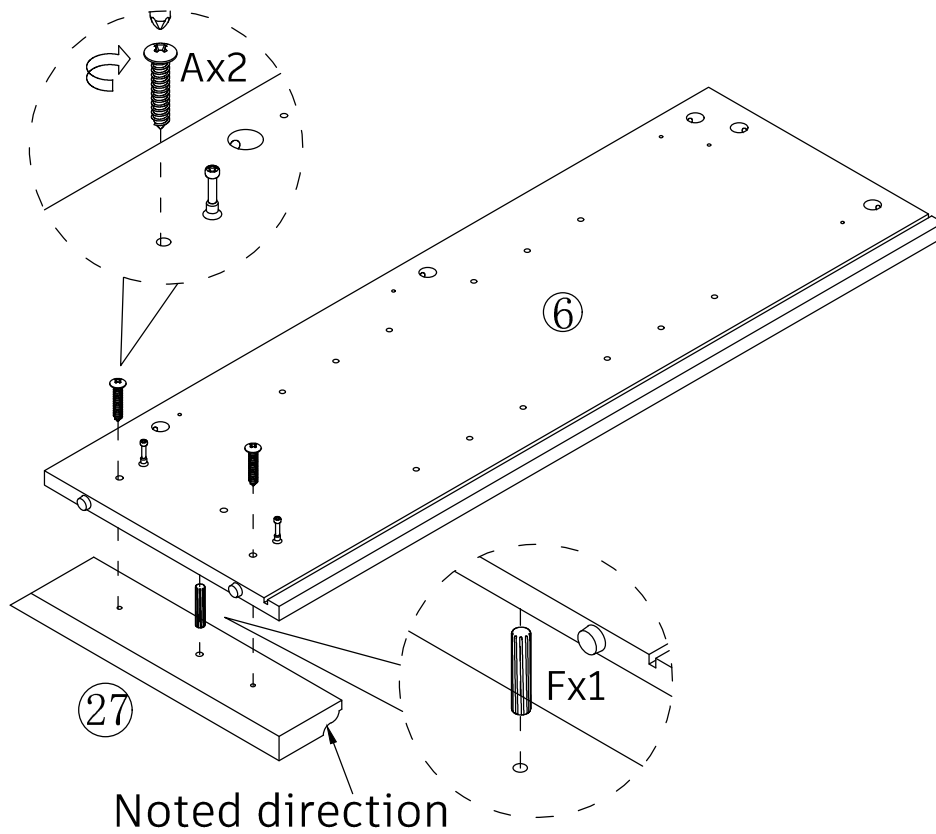

M5*25
Ax2



φ6*30
Fx1

Note: If you encounter any issues, please contact customer service.

20

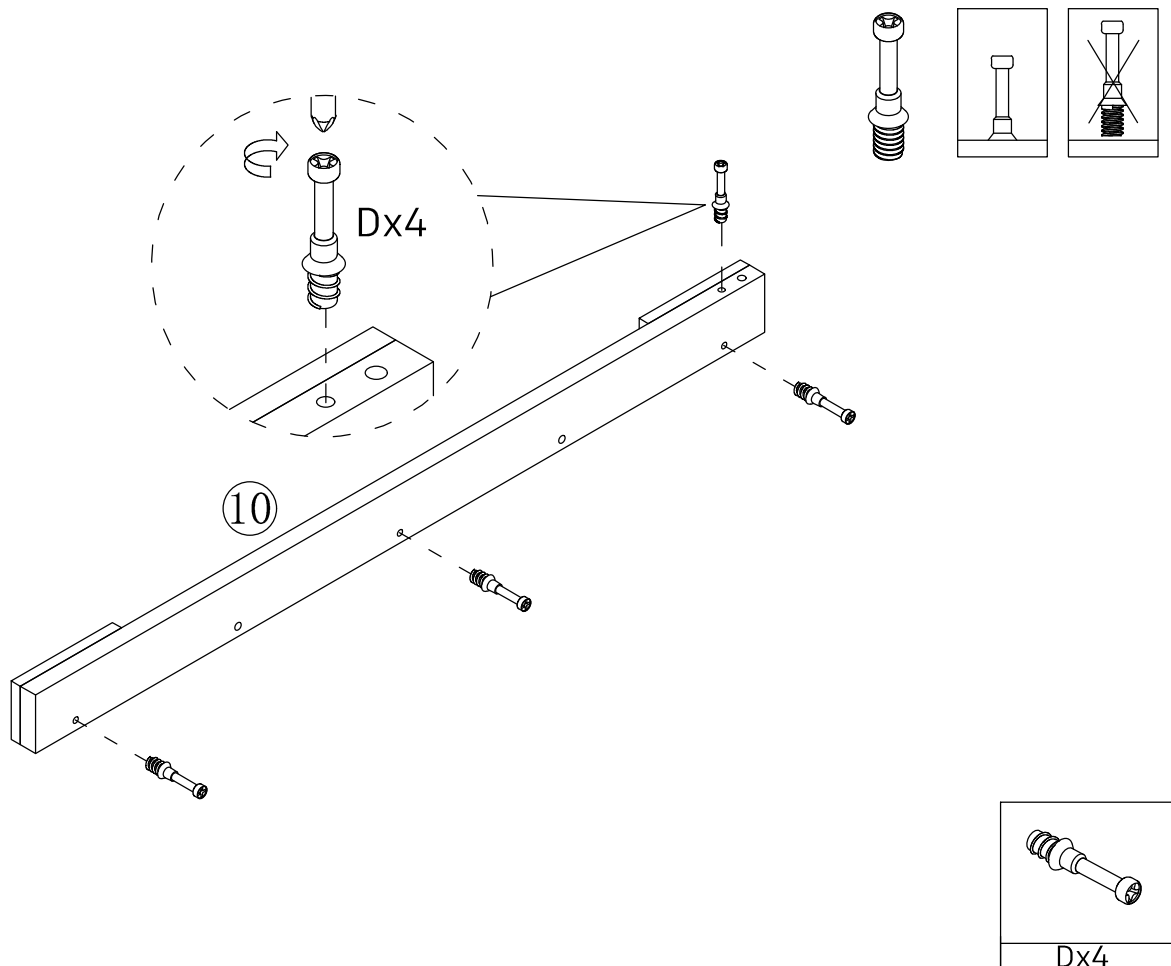

21

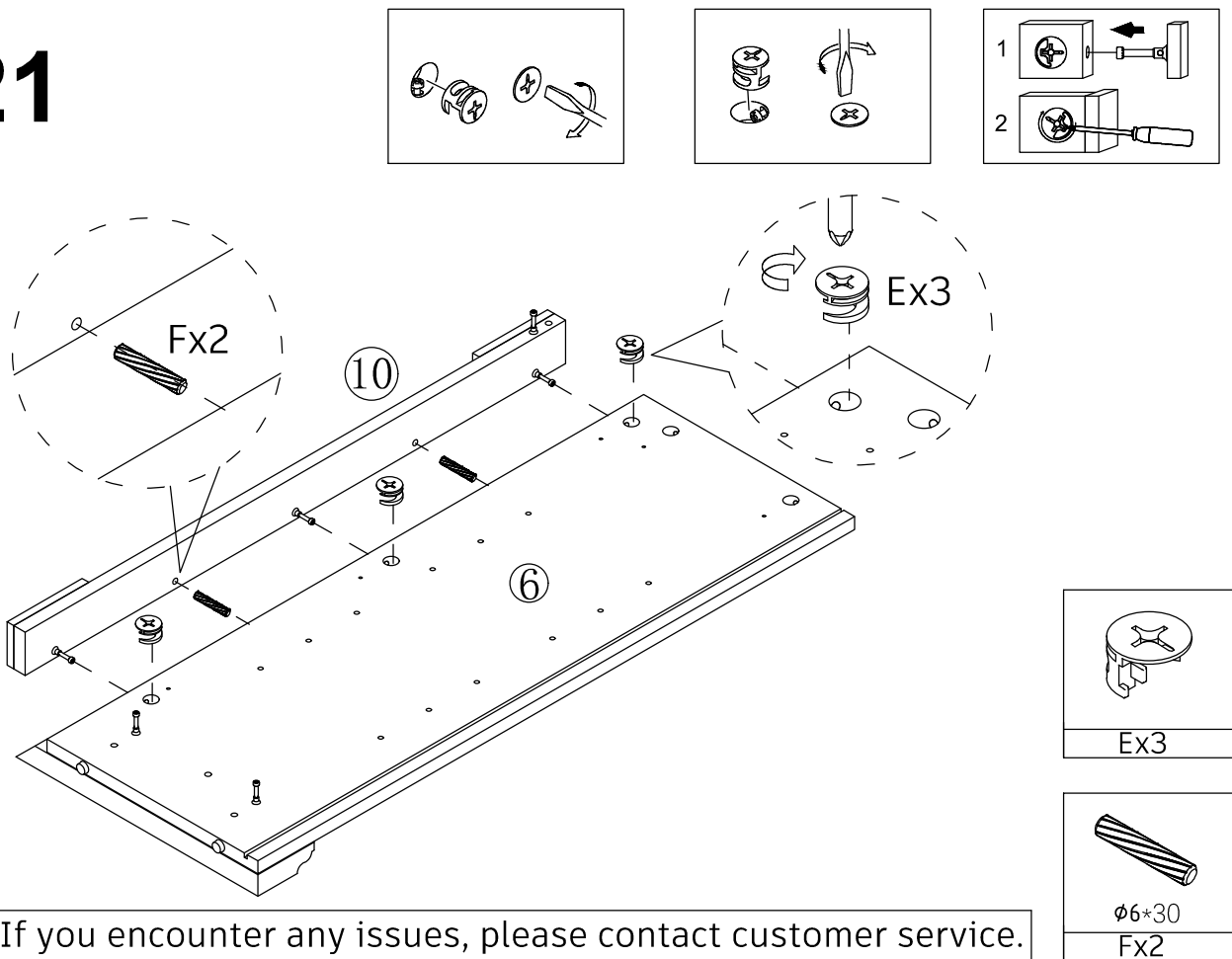

Note: If you encounter any issues, please contact customer service.

22

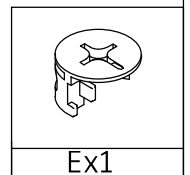
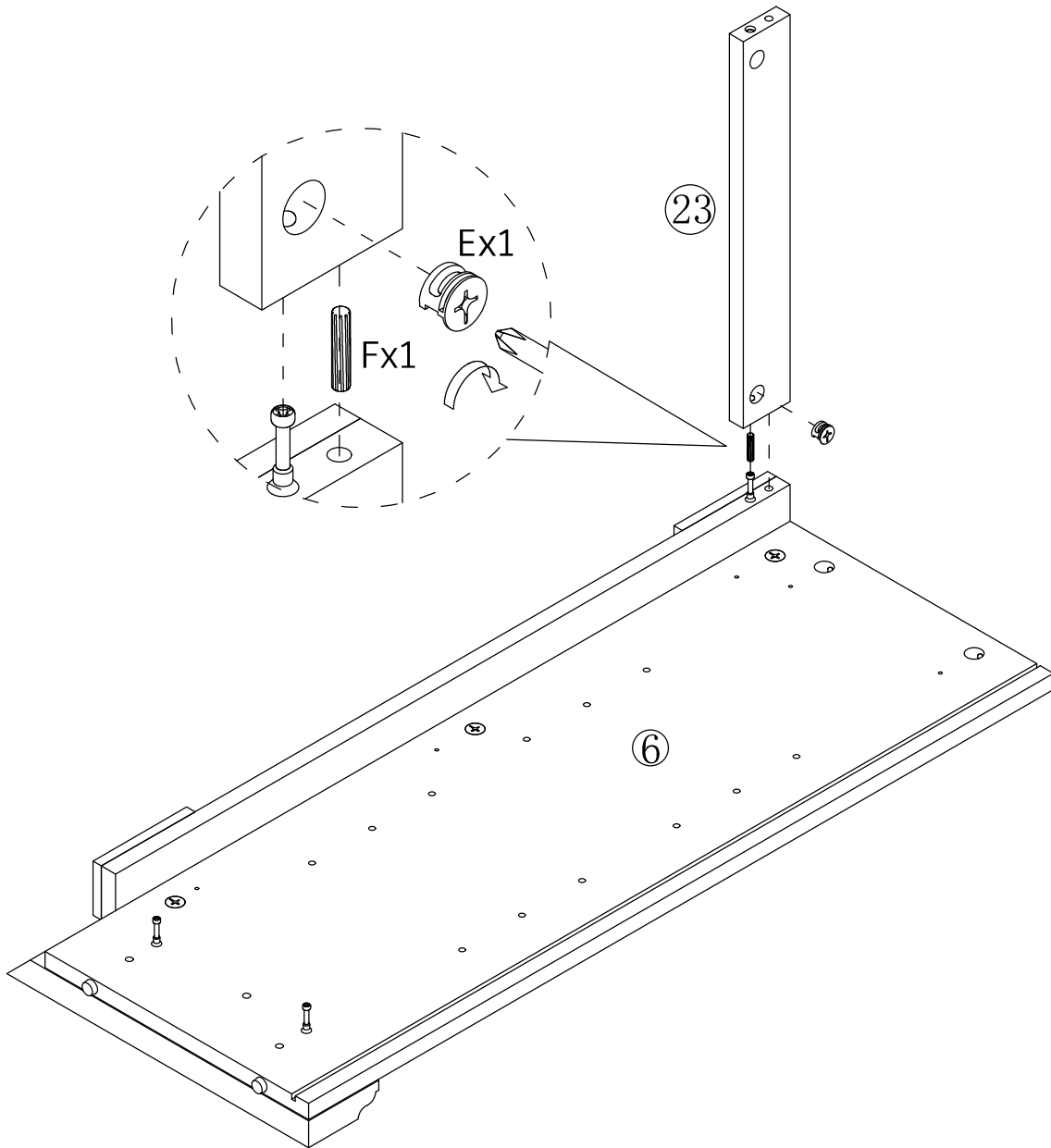
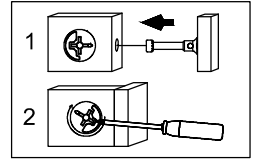
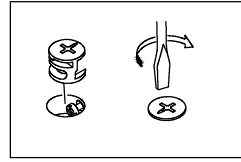
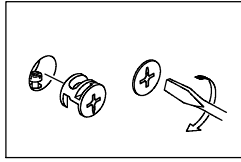

Ex1

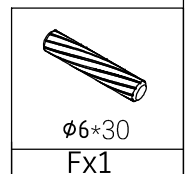

φ6*30
Fx1

Note: If you encounter any issues, please contact customer service.

23

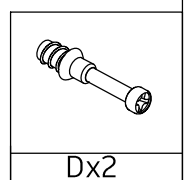
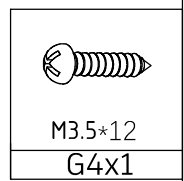
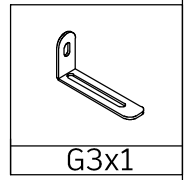
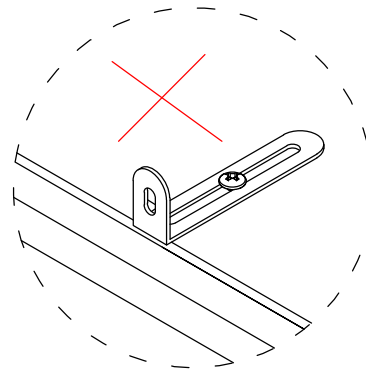
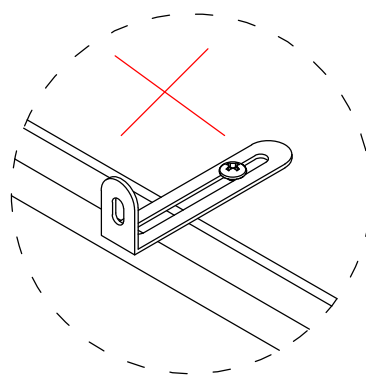
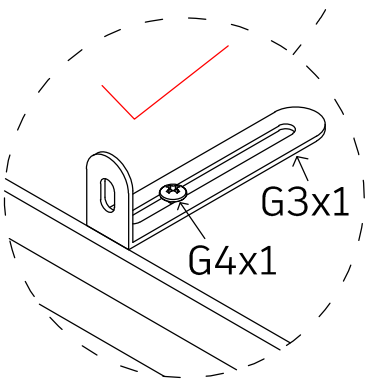
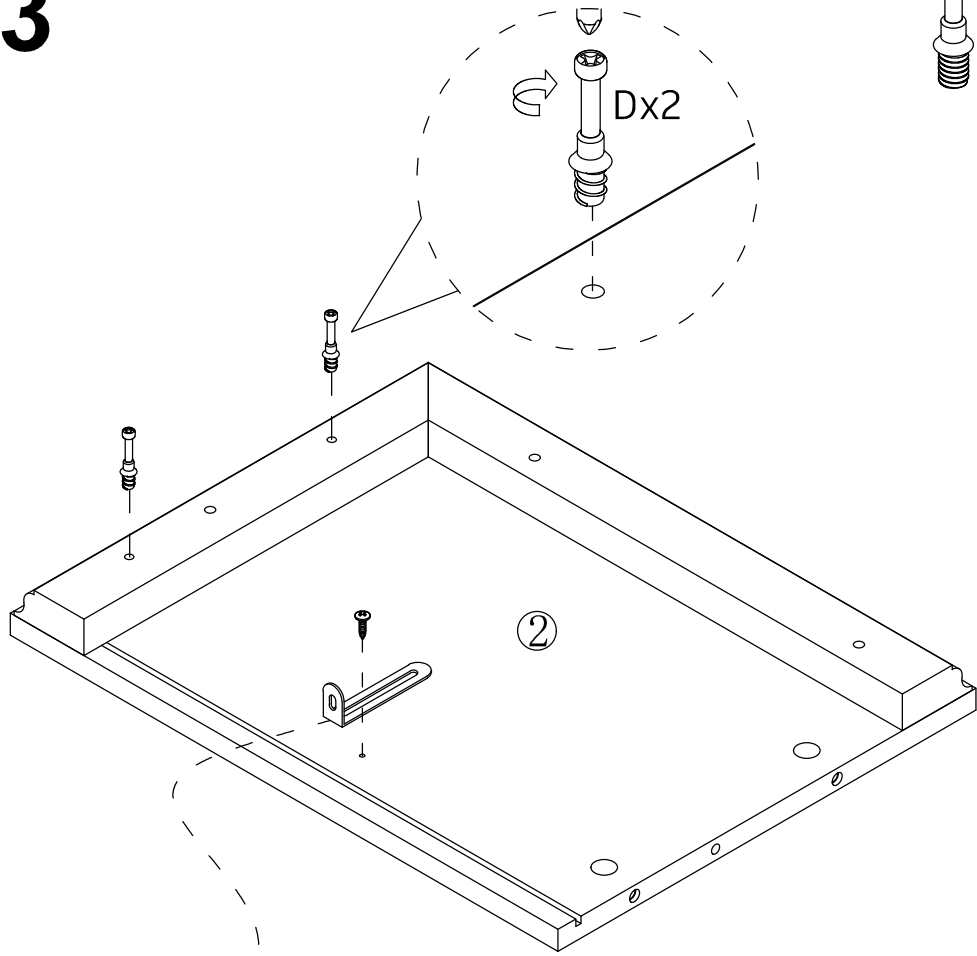
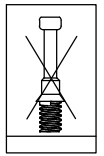
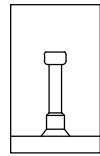
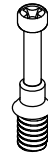

Note: If you encounter any issues, please contact customer service.

24

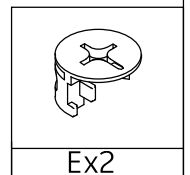
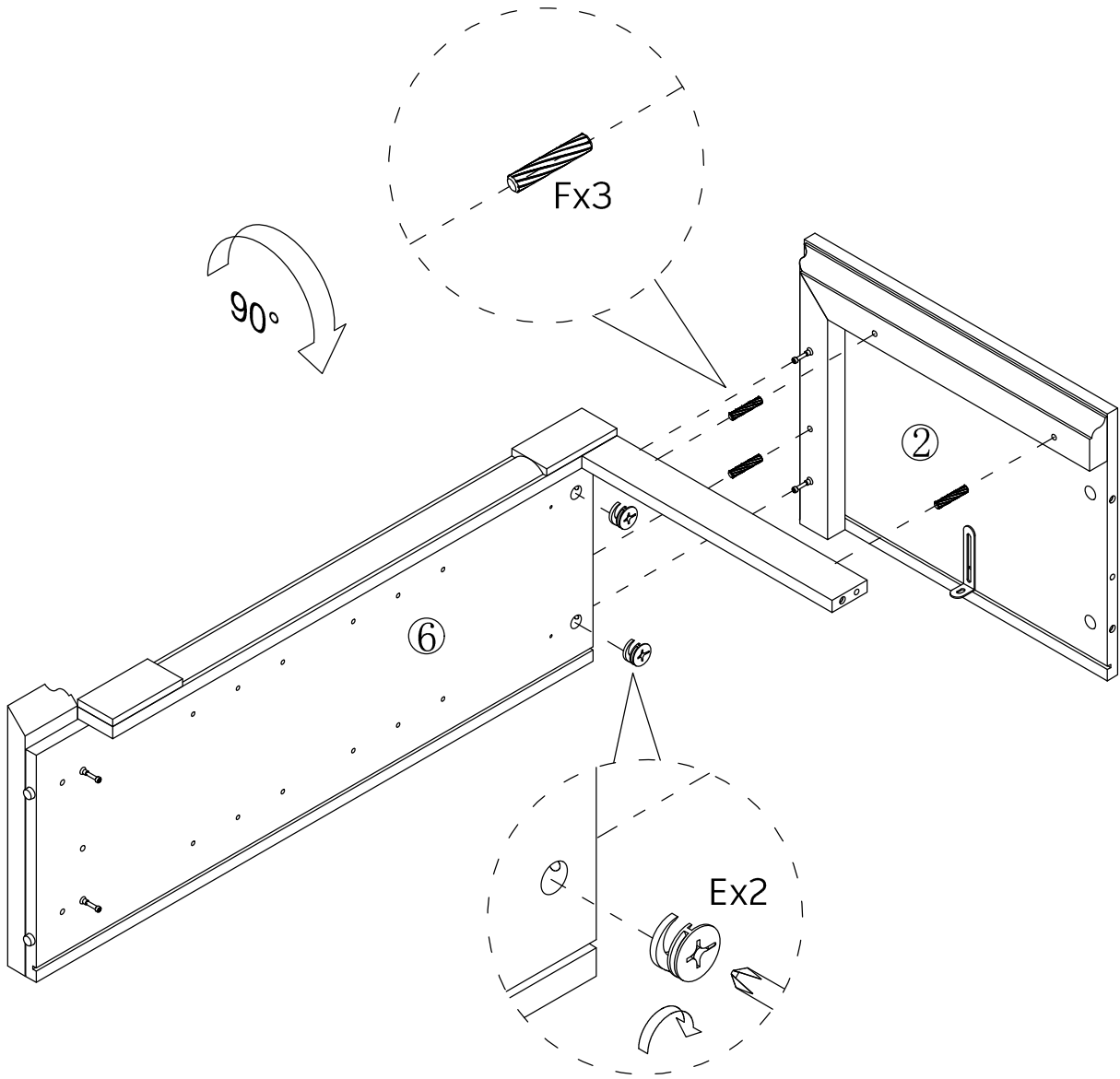
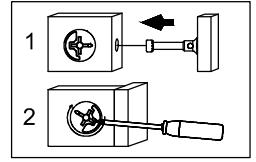
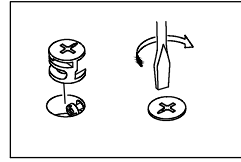
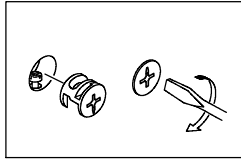

Ex2

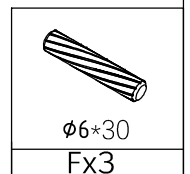

φ6*30
Fx3

Note: If you encounter any issues, please contact customer service.

25

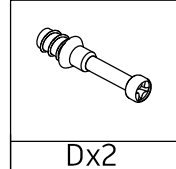
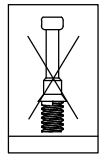
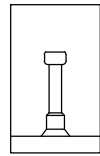
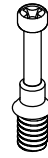
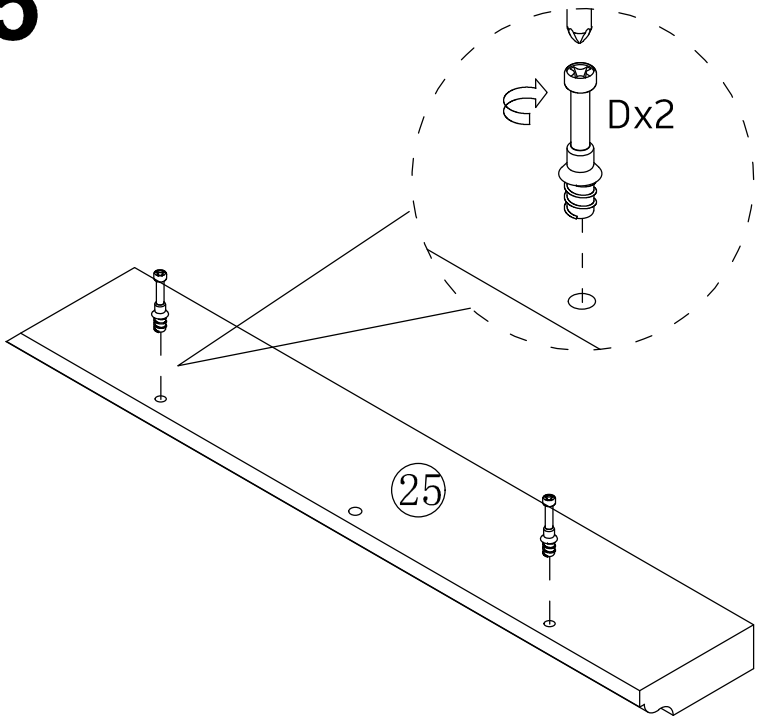

26

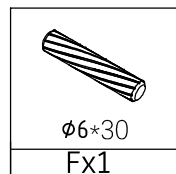
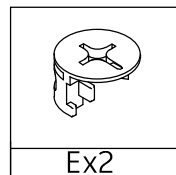
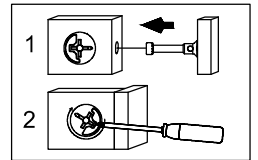
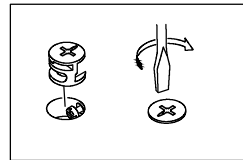
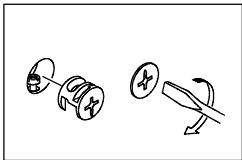
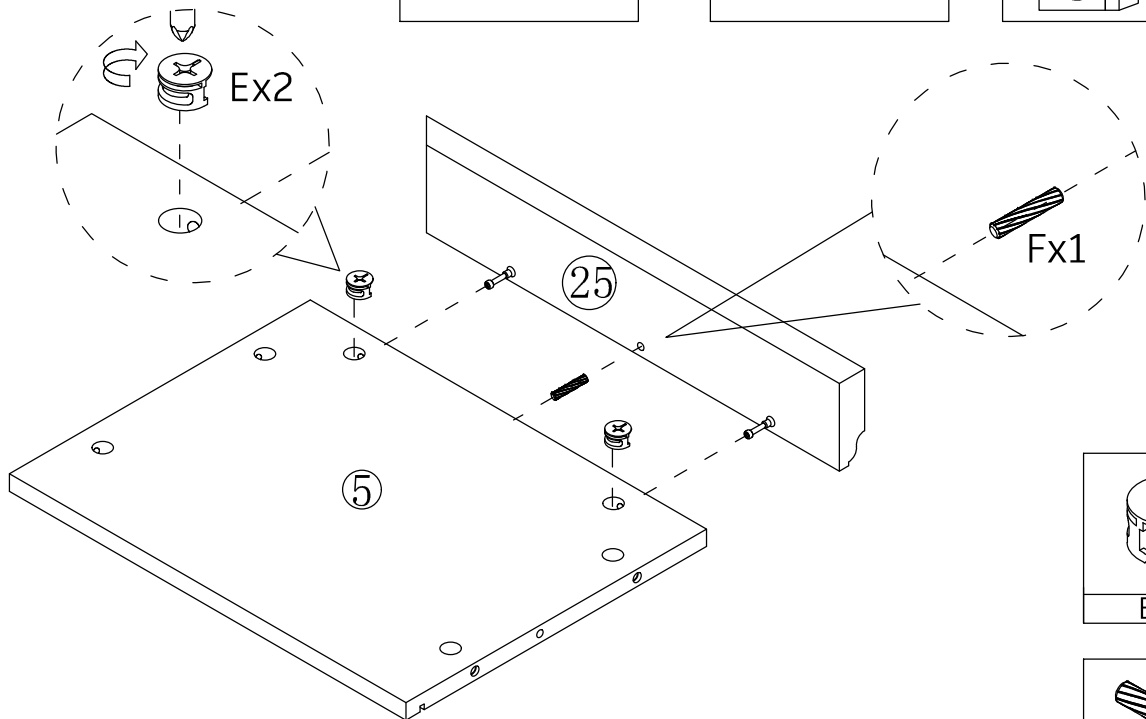

Note: If you encounter any issues, please contact customer service.

27

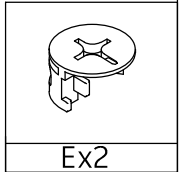
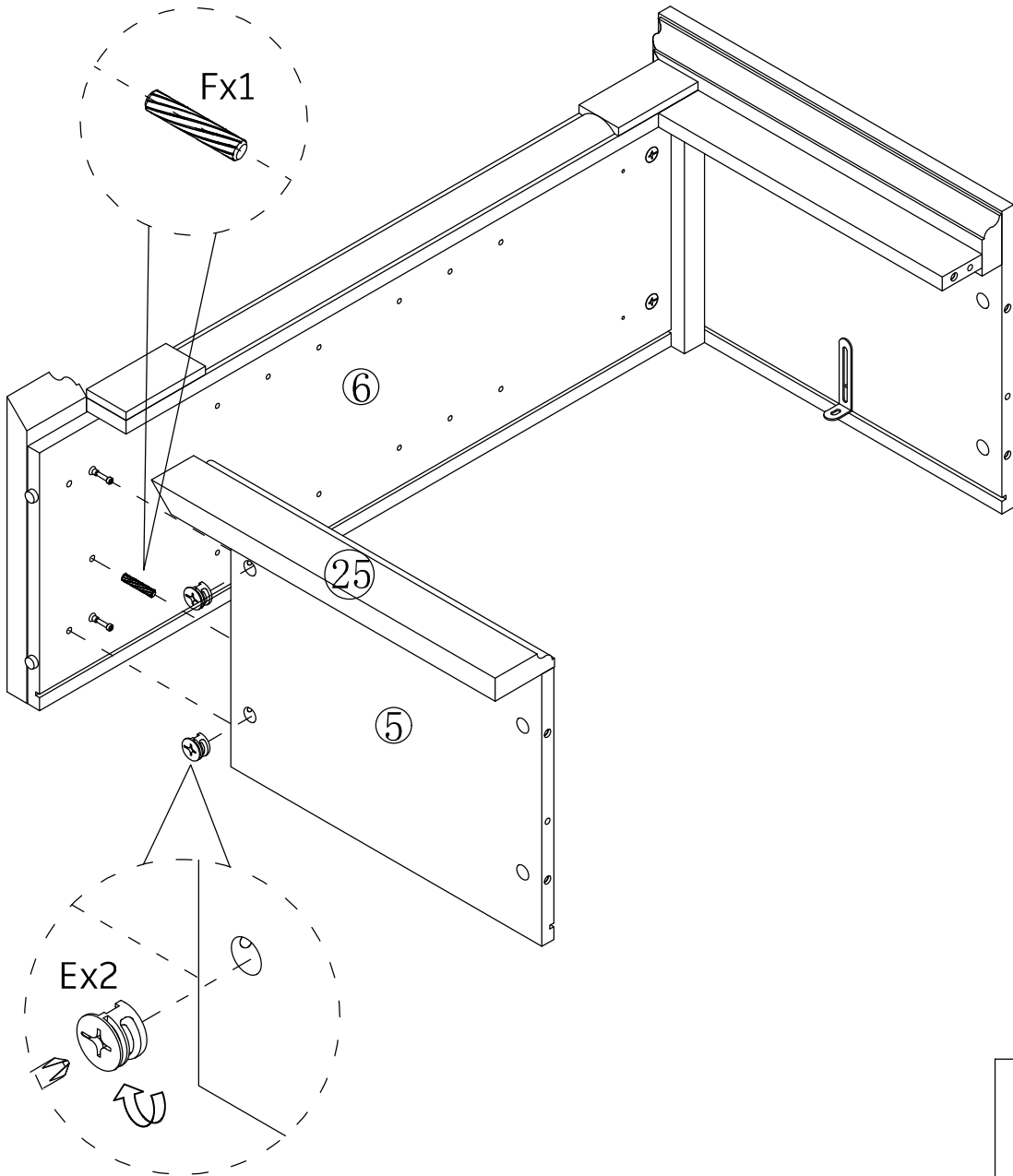
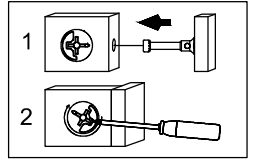
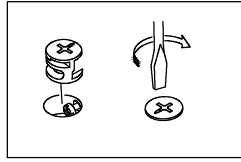
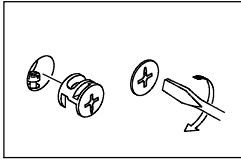

Ex2

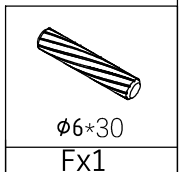

φ6*30
Fx1

Note: If you encounter any issues, please contact customer service.

28

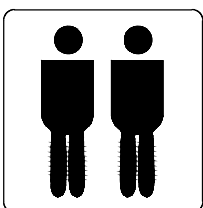
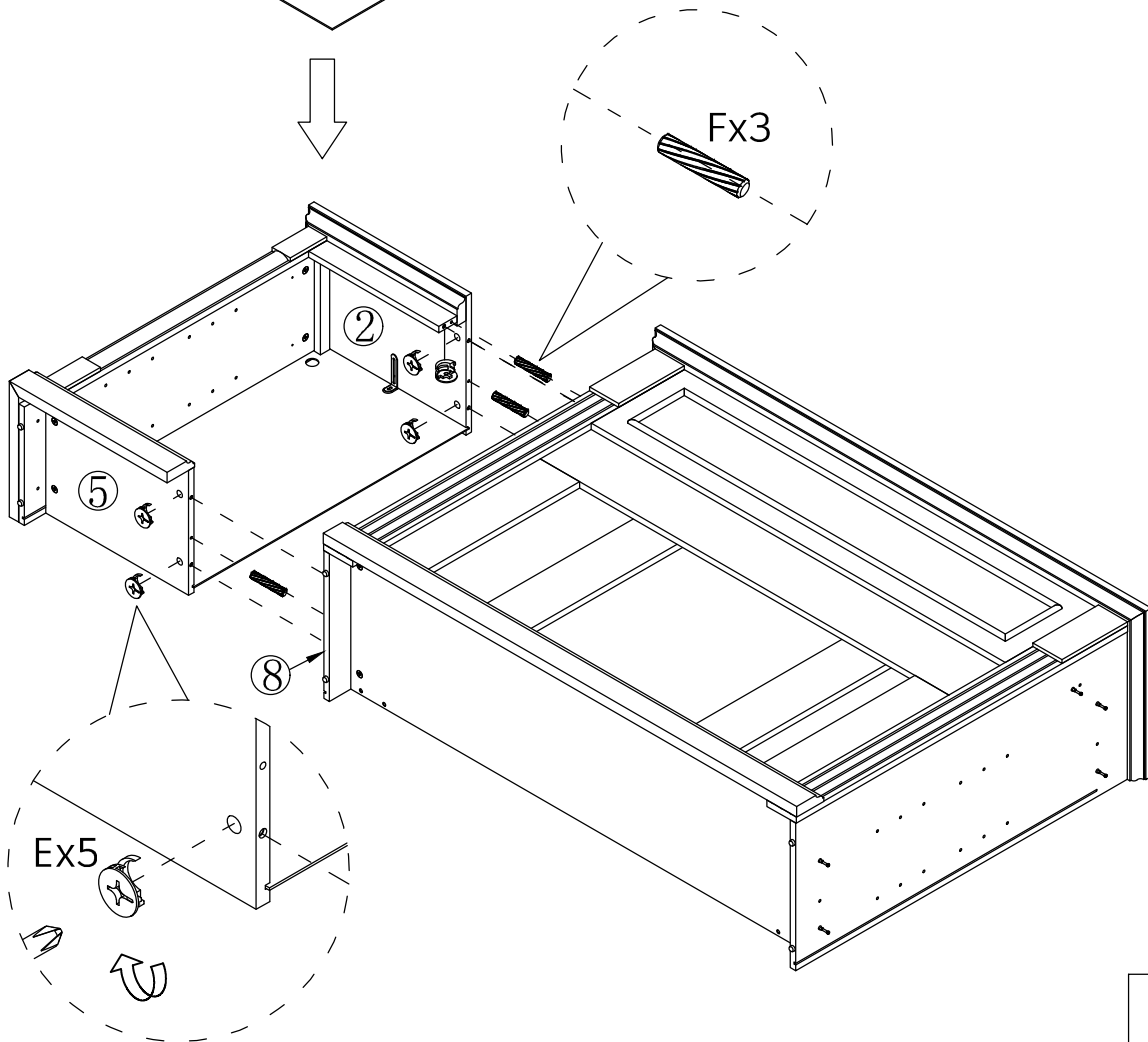
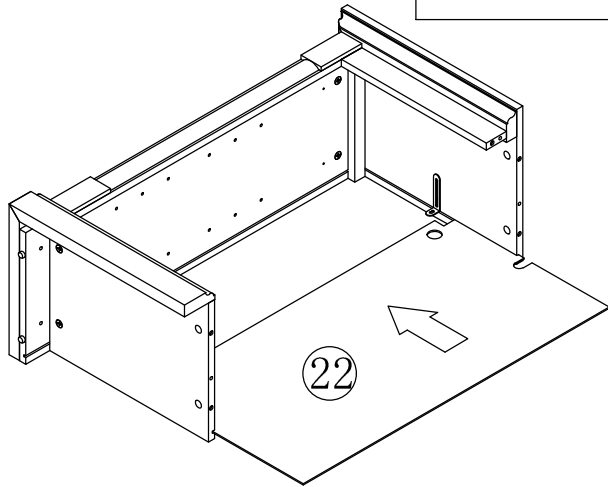
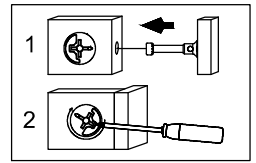
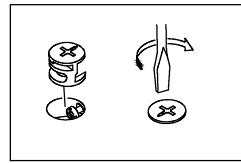
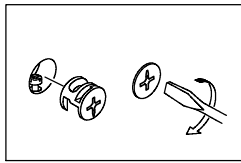

This step require two people to be completed.

Note: If you encounter any issues, please contact customer service.

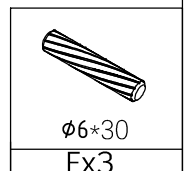
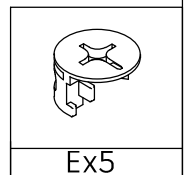

29

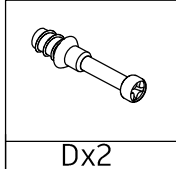
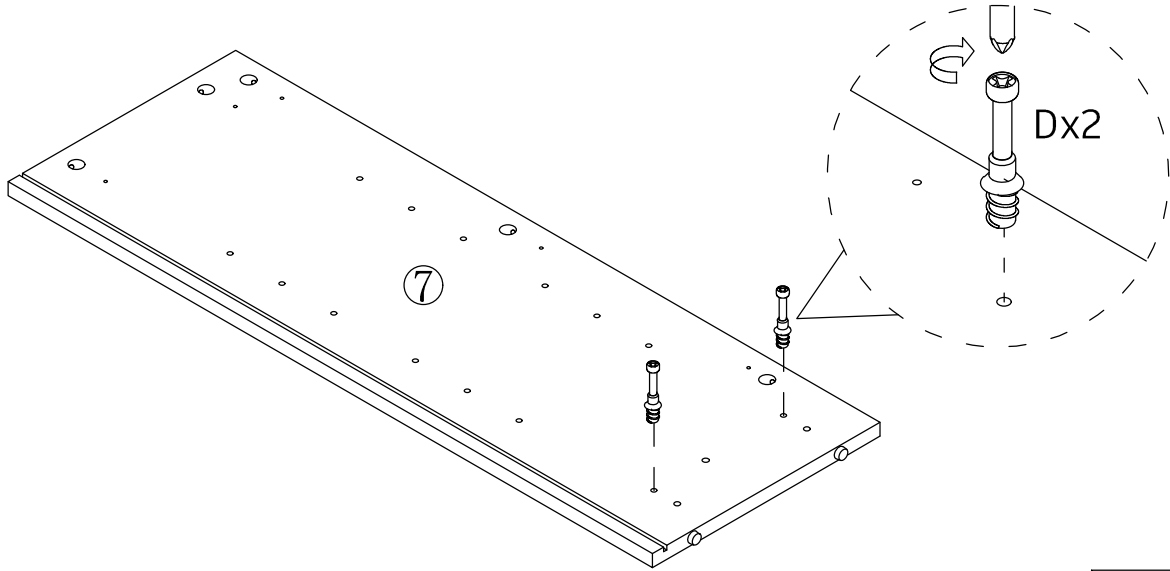
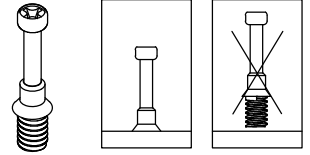

30

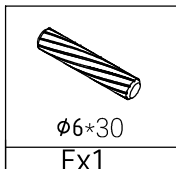
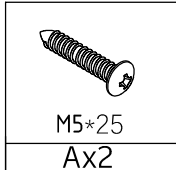
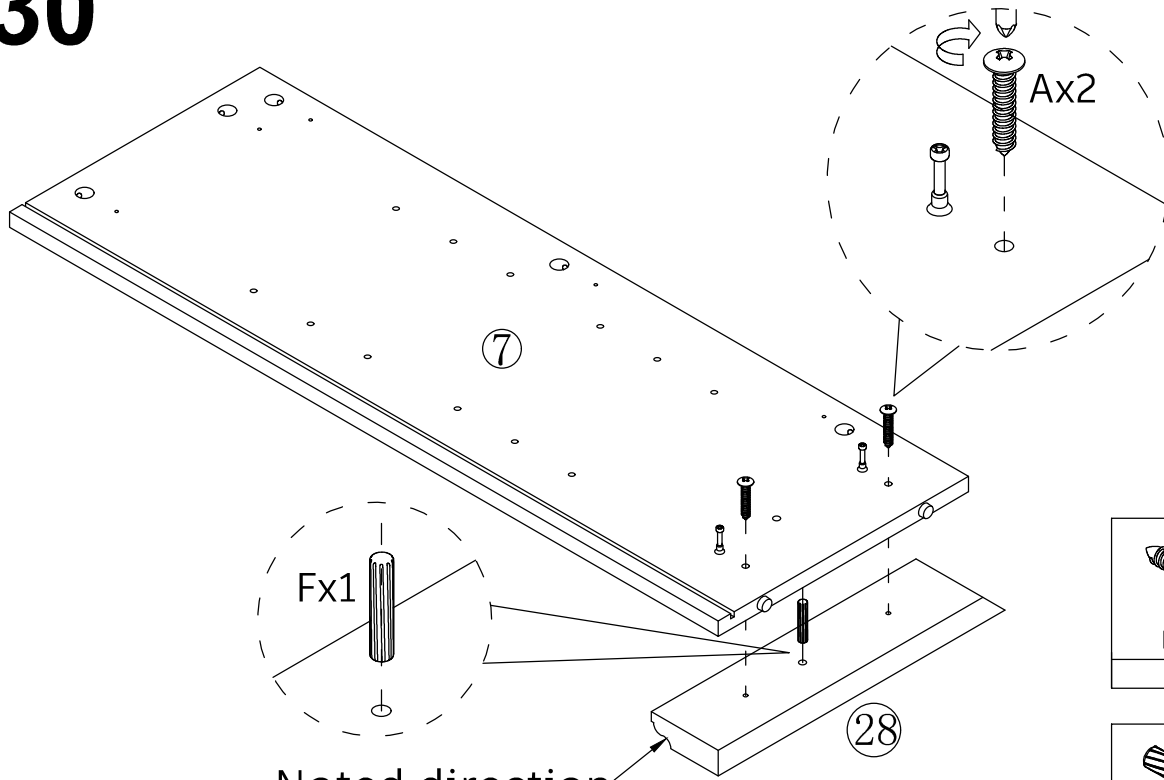

Noted direction

Note: If you encounter any issues, please contact customer service.

31

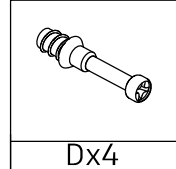
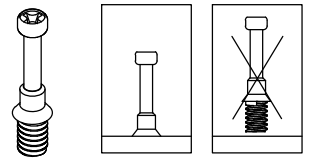
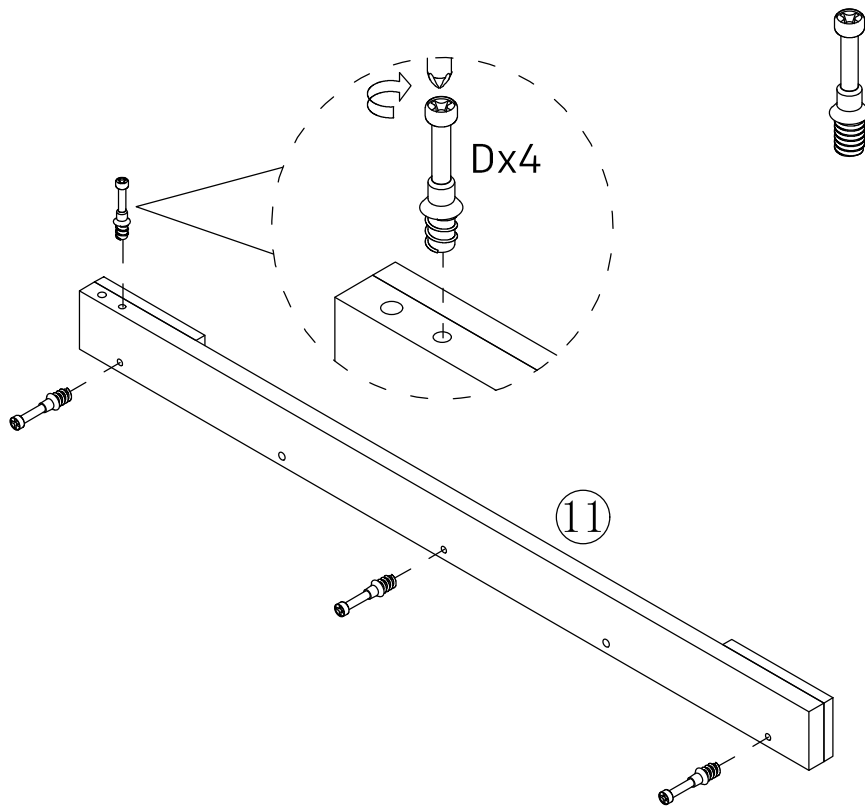

32

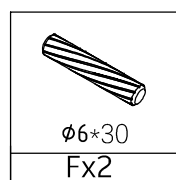
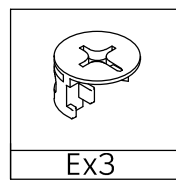
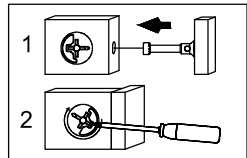
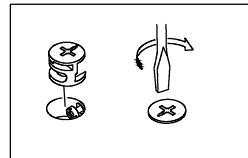
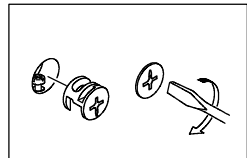
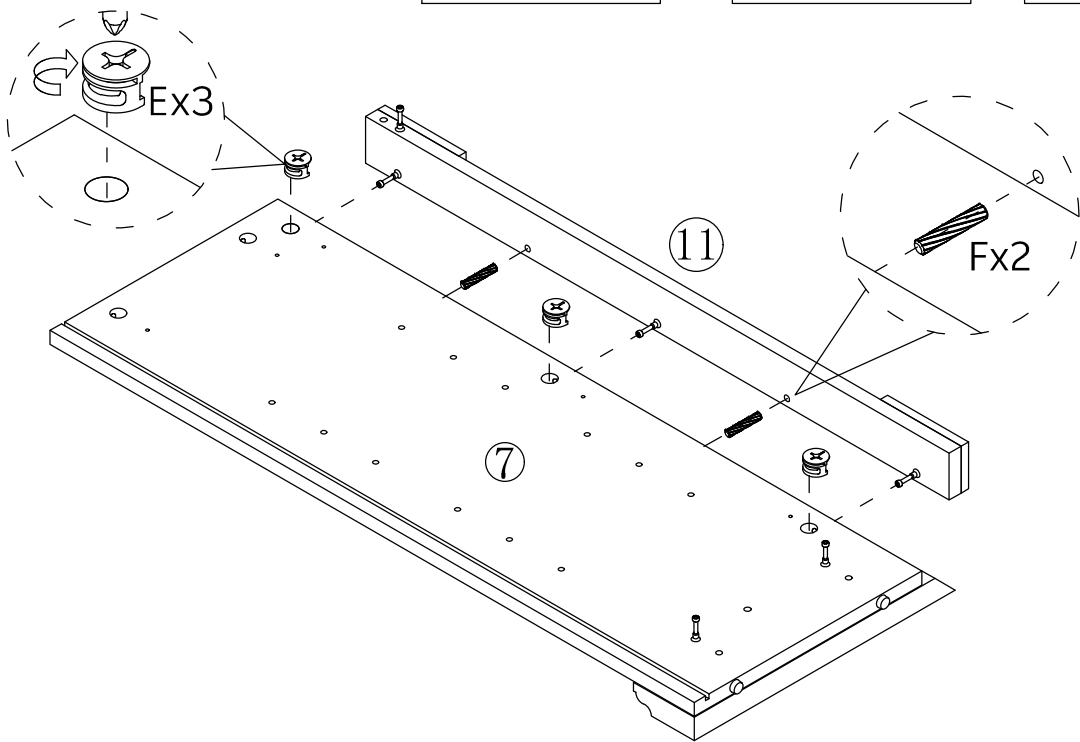

Note: If you encounter any issues, please contact customer service.

33

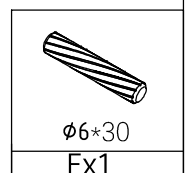
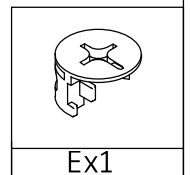
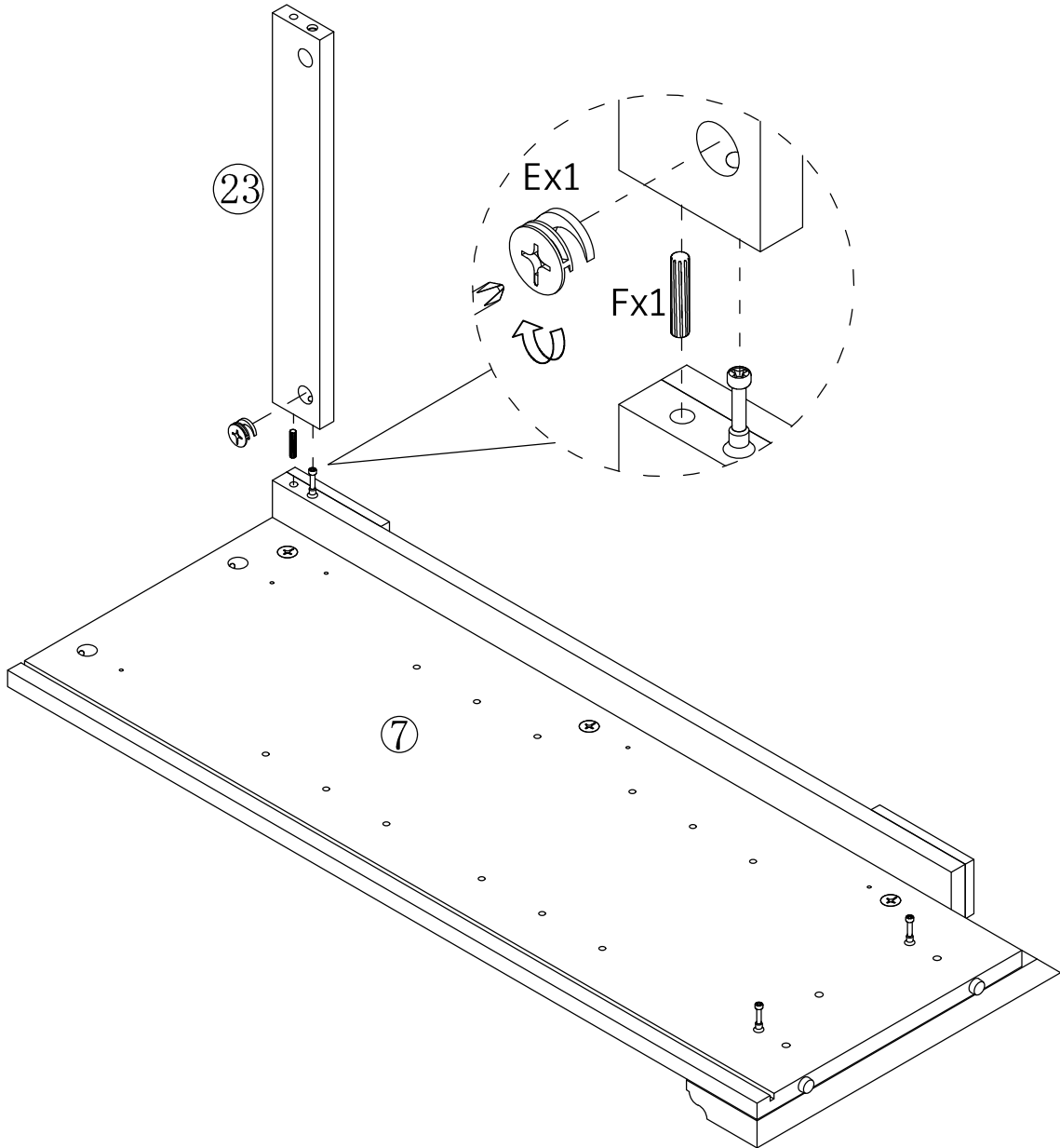
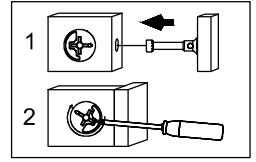
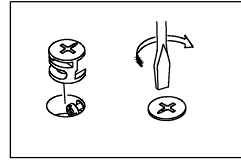
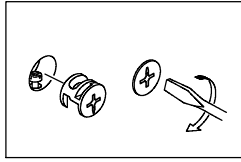

Note: If you encounter any issues, please contact customer service.

34

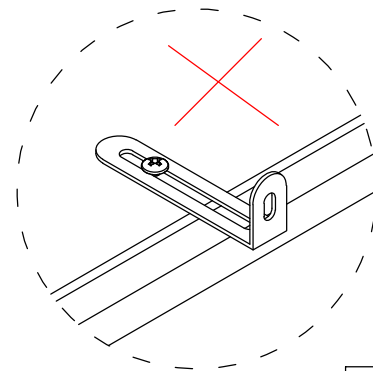
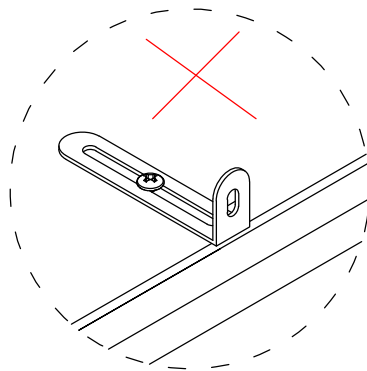
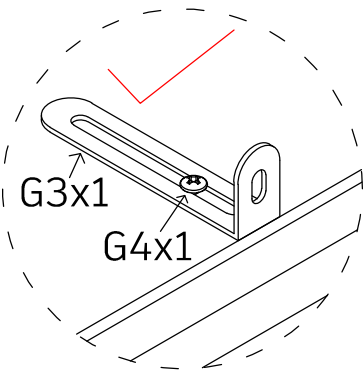
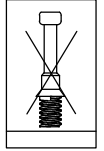
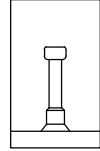
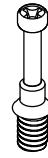
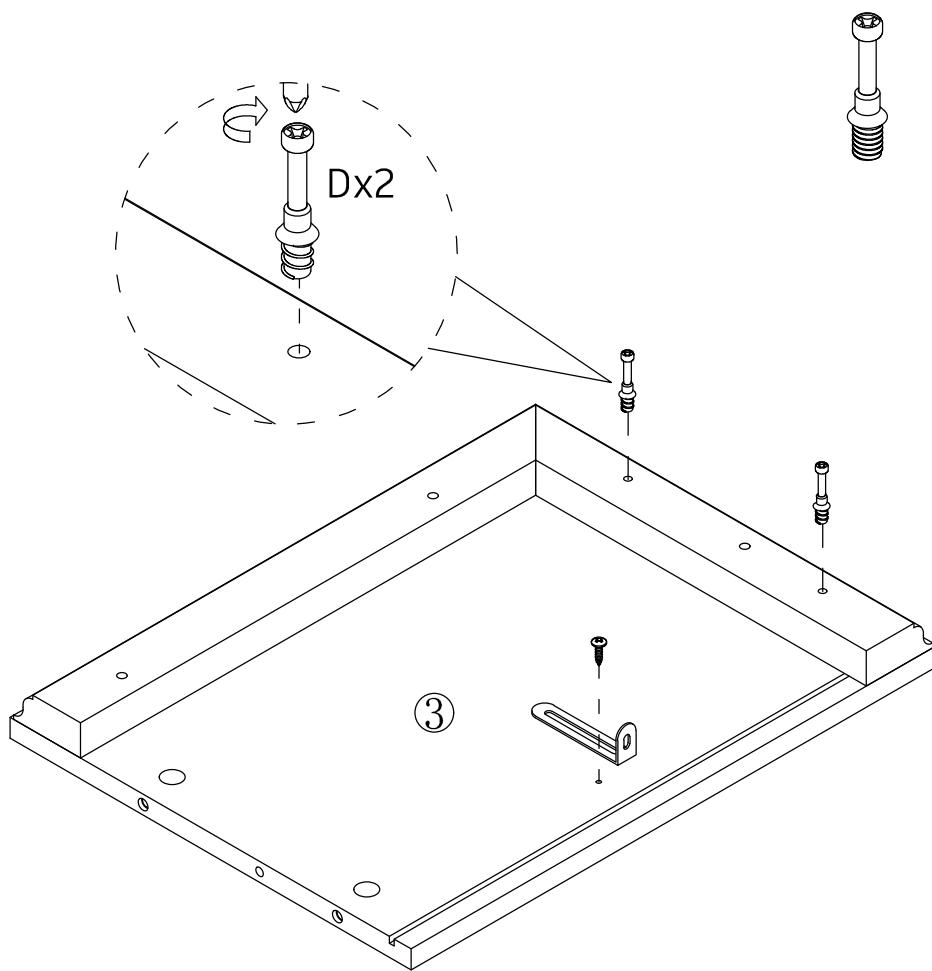

G3x1

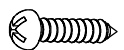

M3.5*12
G4x1

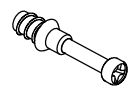

Dx2

Note: If you encounter any issues, please contact customer service.

35

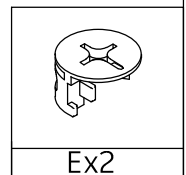
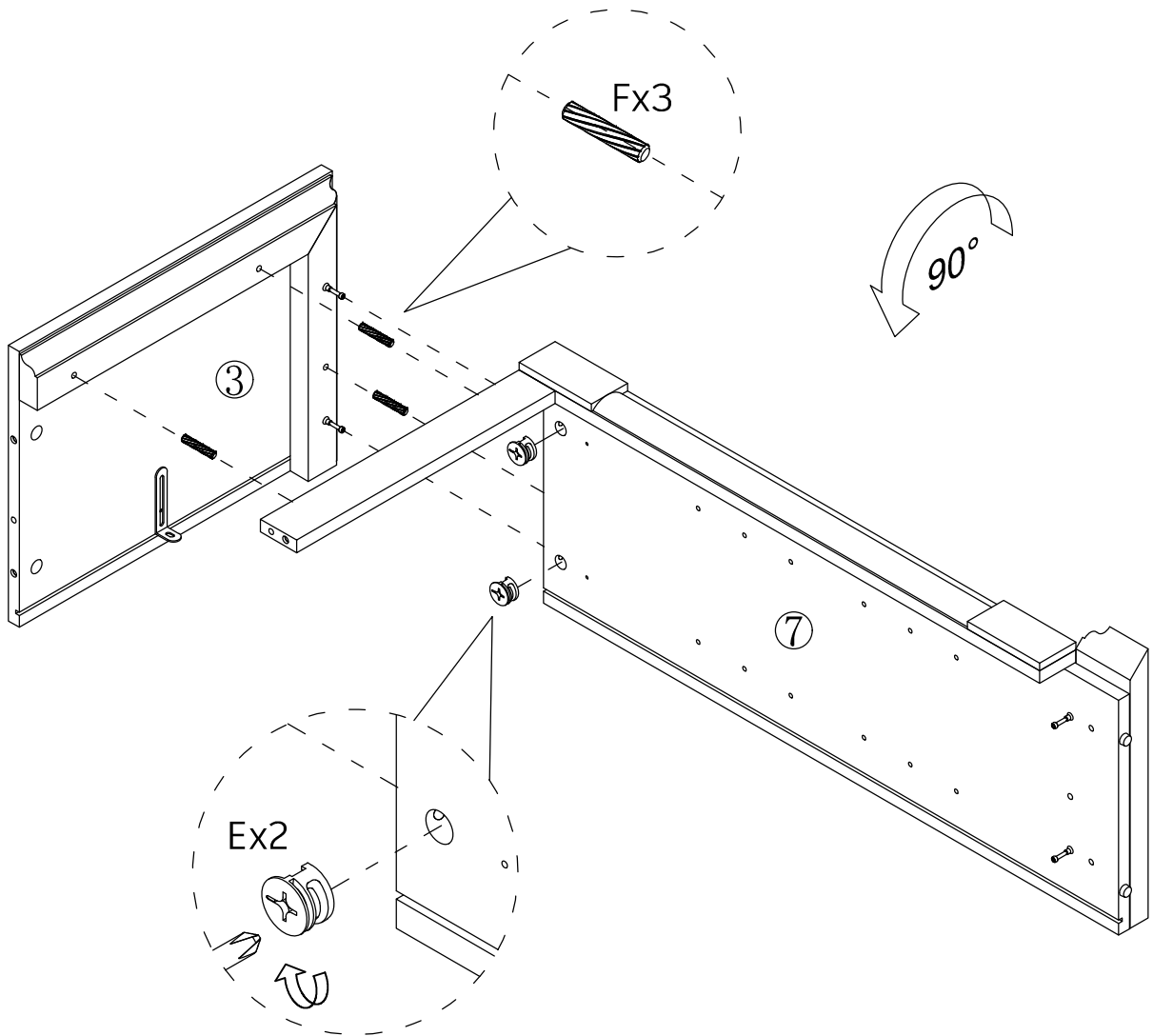
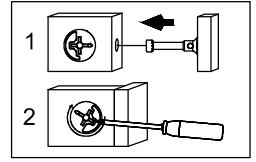
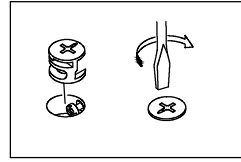
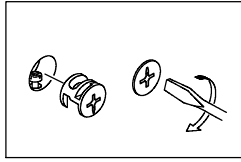

Ex2

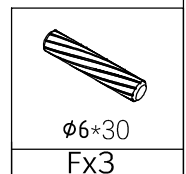

φ6*30
Fx3

Note: If you encounter any issues, please contact customer service.

36

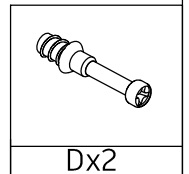
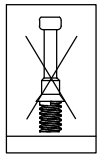
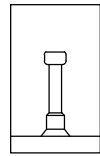
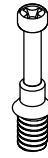
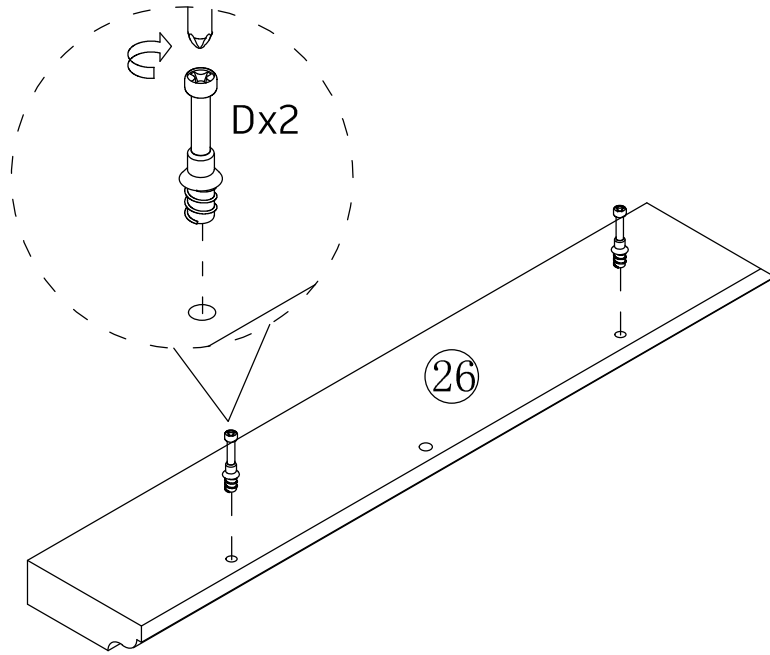

37

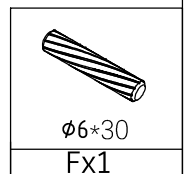
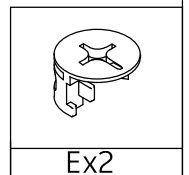
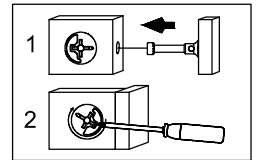
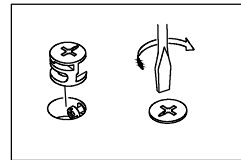
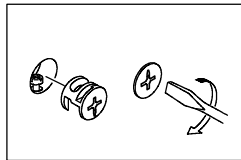
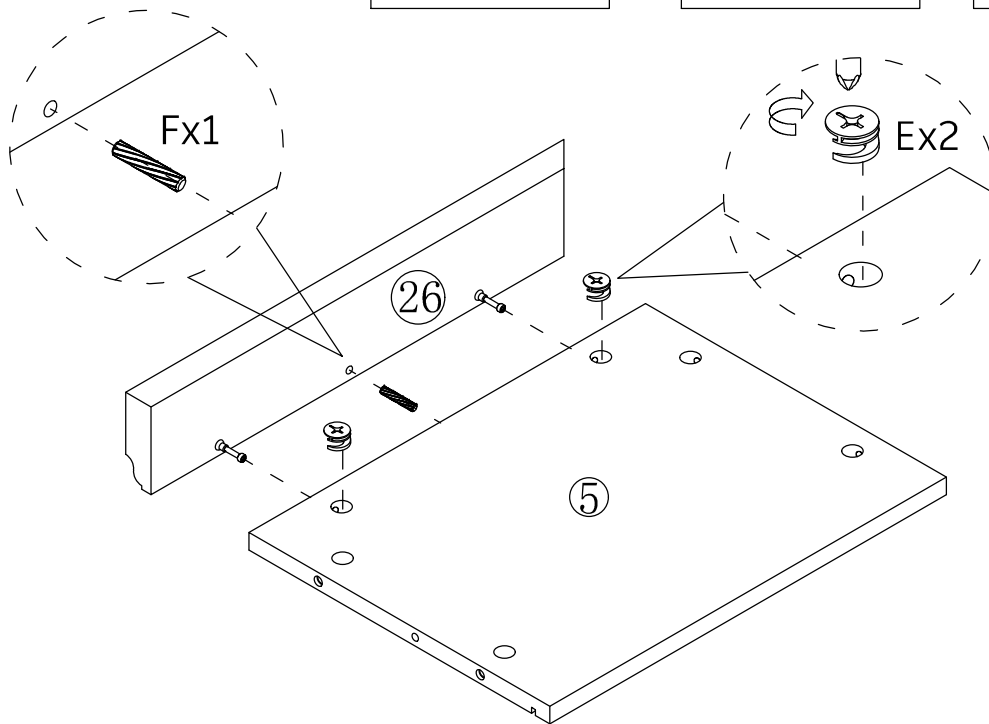

Note: If you encounter any issues, please contact customer service.

38

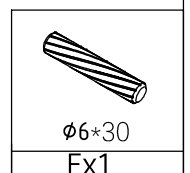
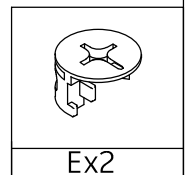
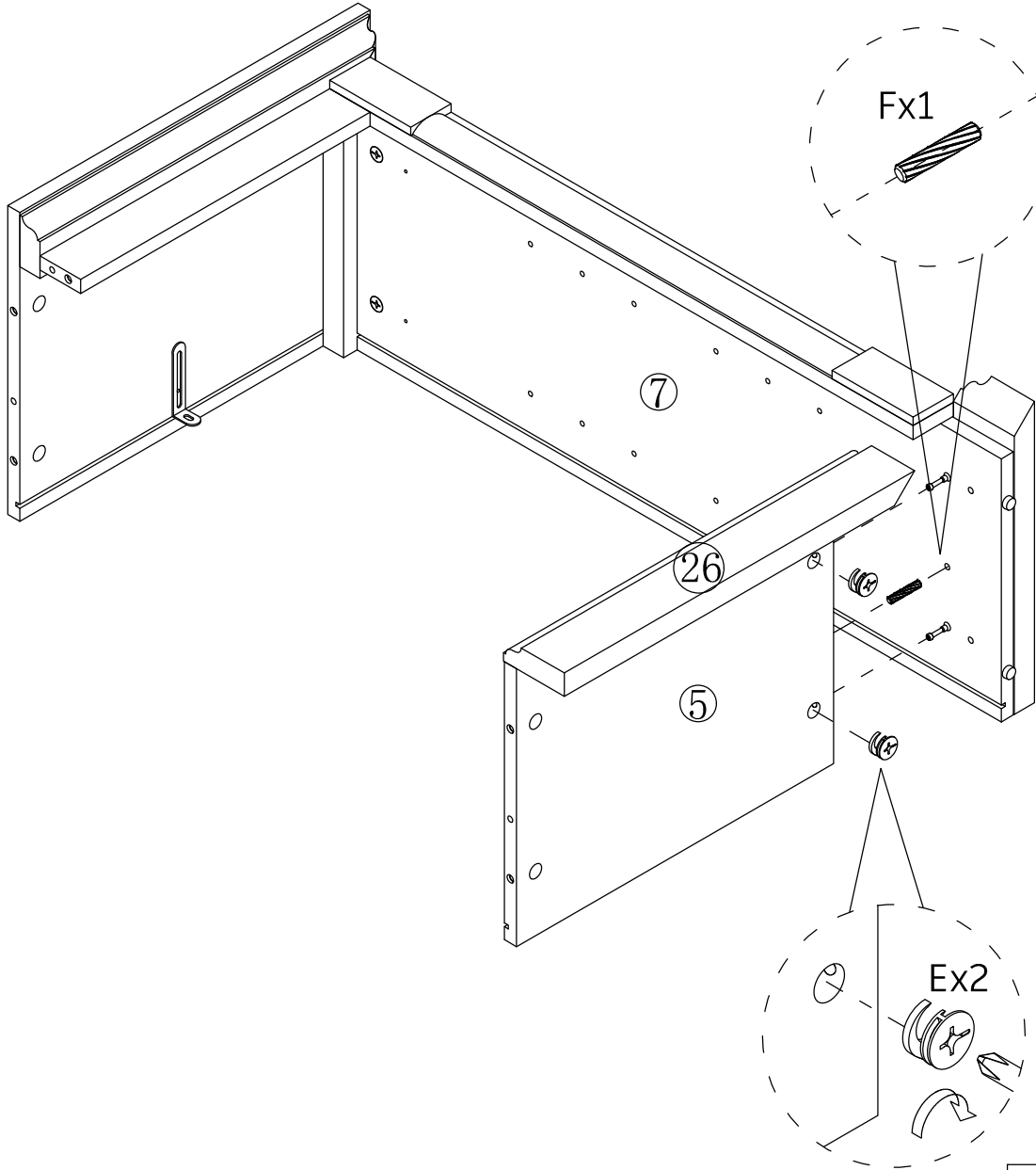
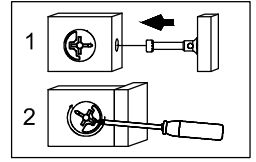
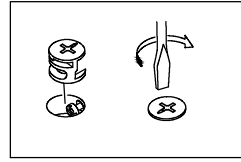
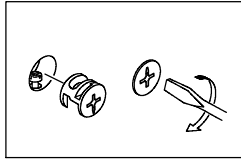

Note: If you encounter any issues, please contact customer service.

39

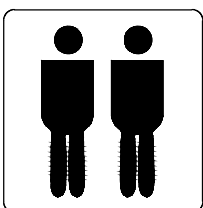
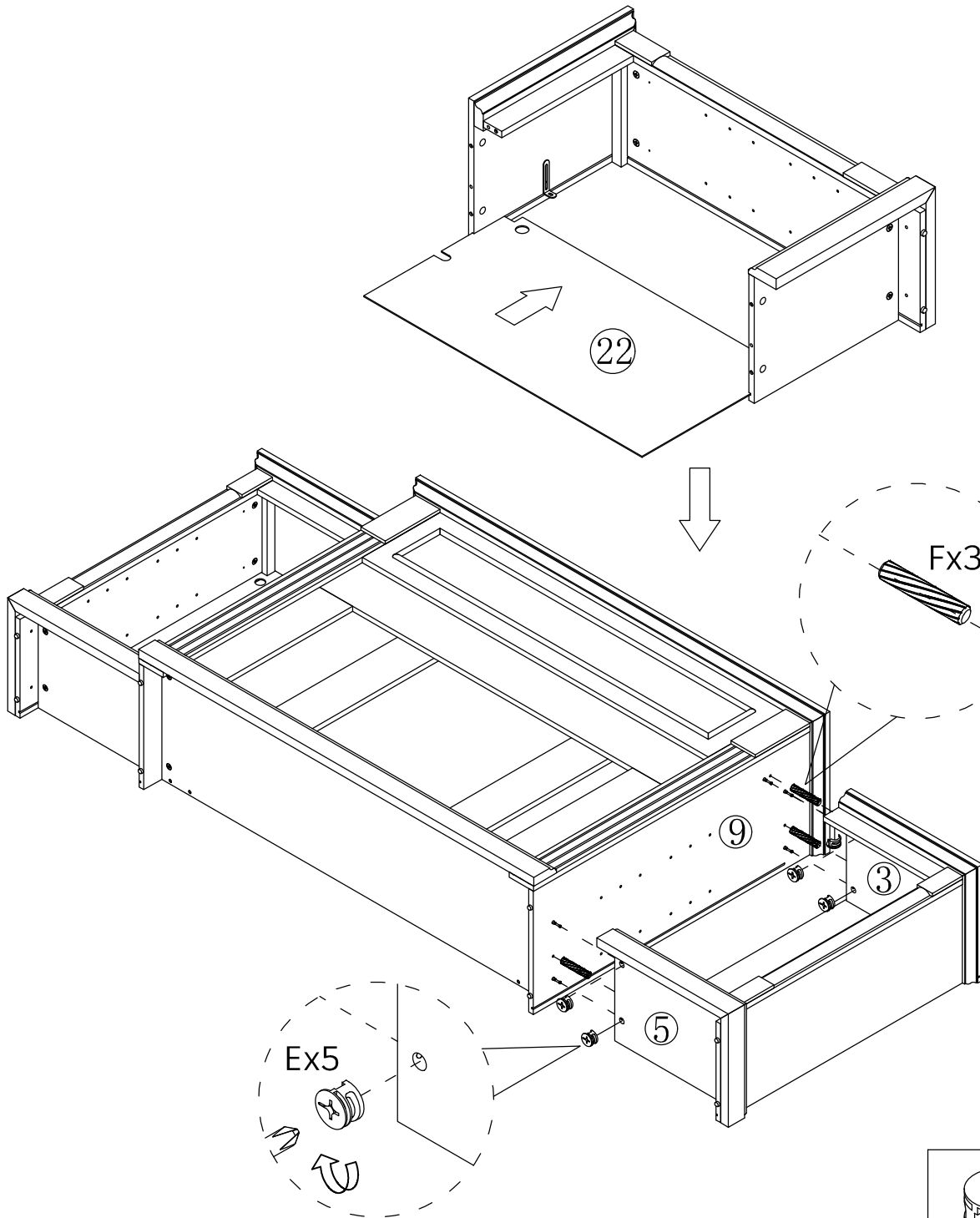
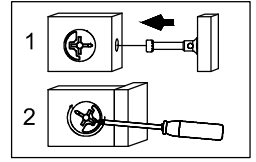
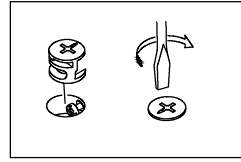
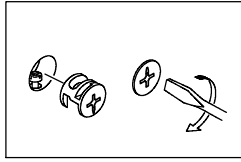

This step require two people to be completed.

Note: If you encounter any issues, please contact customer service.

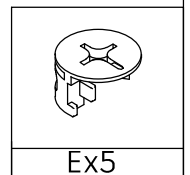

Ex5

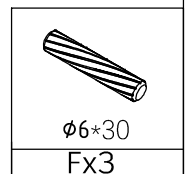

ø6*30
Fx3

40

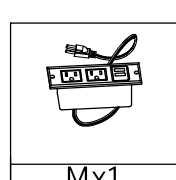
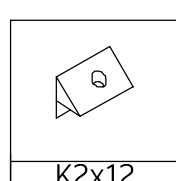
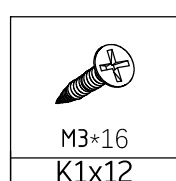
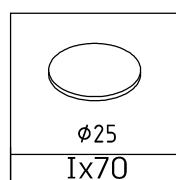
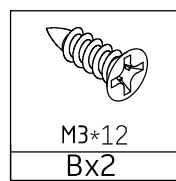
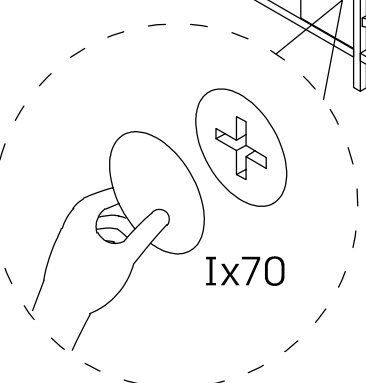
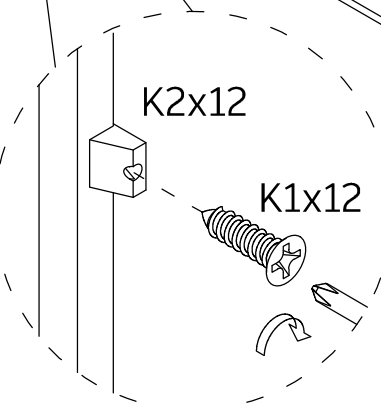
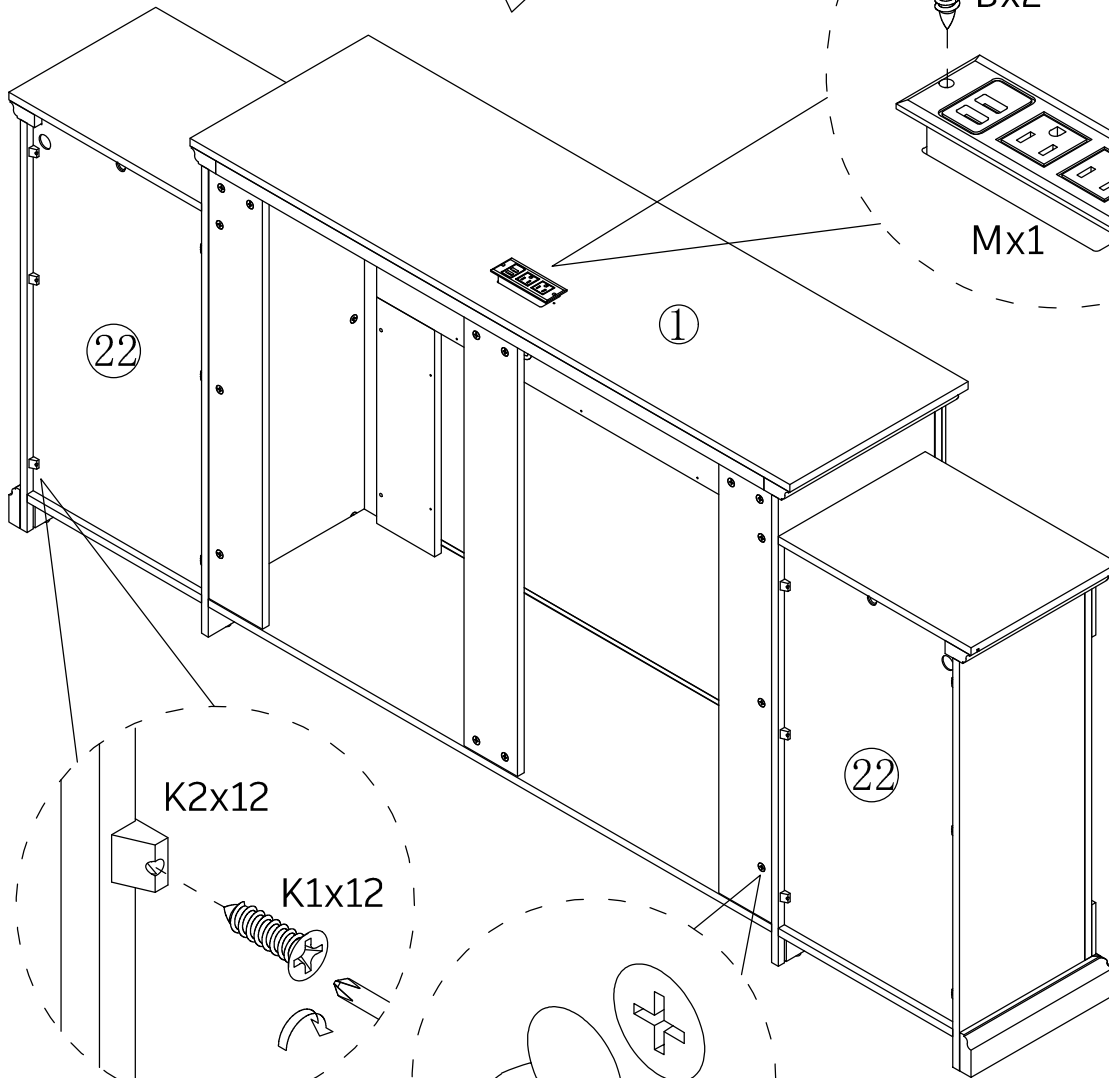
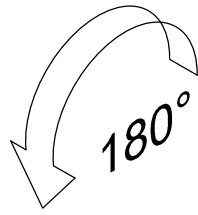

Peel a CAM COVER from the CAM COVER CARD and stick one onto each visible HIDDEN CAM.



This step require two people to be completed.

Note: If you encounter any issues, please contact customer service.

41

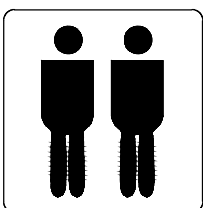
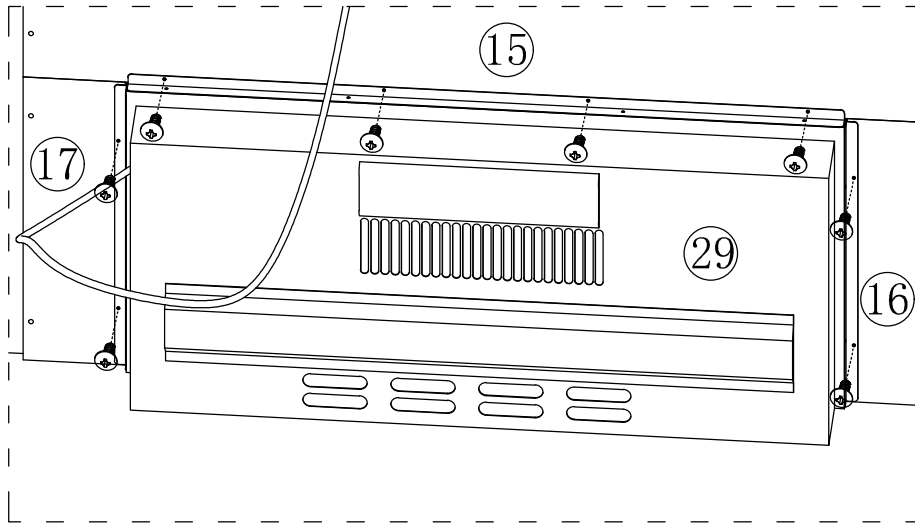
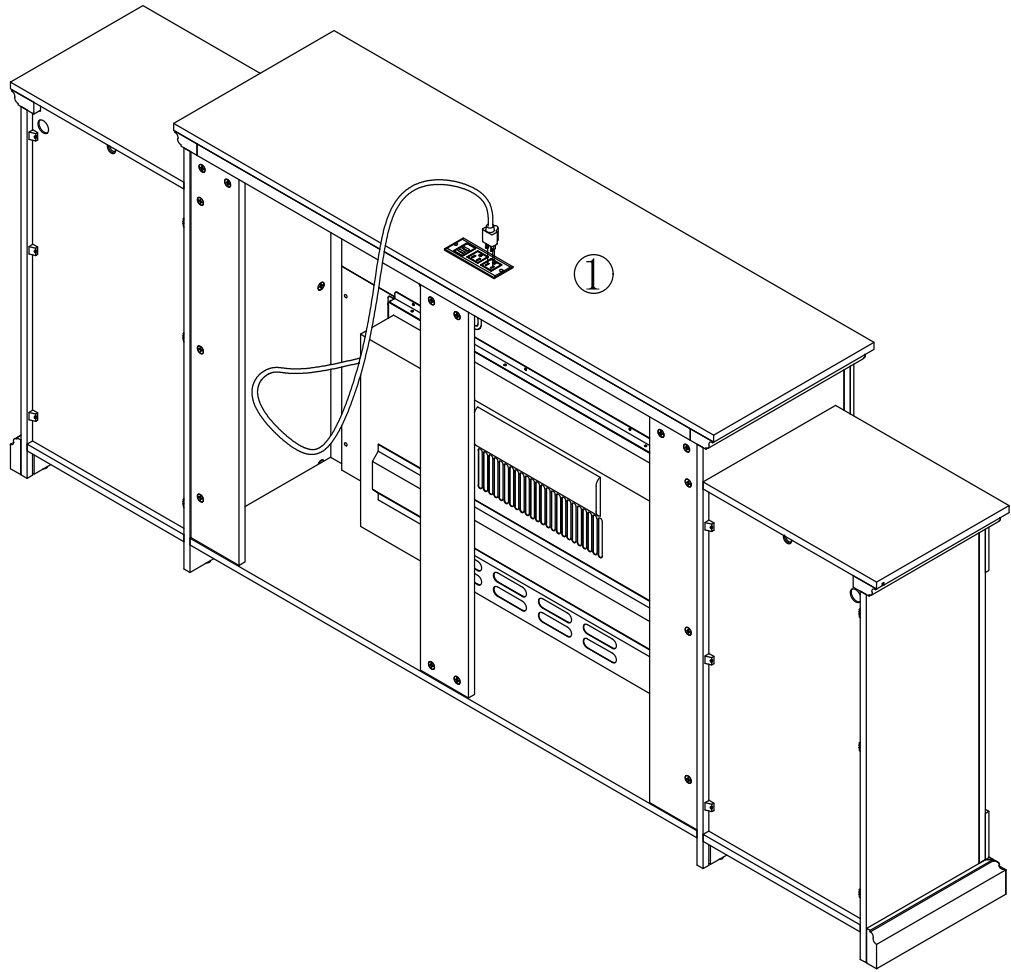

This step require two people to be completed.

Note: If you encounter any issues, please contact customer service.

42

Please note when installing the lamp belt:

1. Clean the board 6 and 7 before use.
 - 2, the lamp tape should pay attention to compaction.
 - 3, after the lamp tape is pasted, cut off the extra adhesive strip at the end, and let it stand for 10 minutes until the glue sticks firmly.
- Then proceed to the next step.

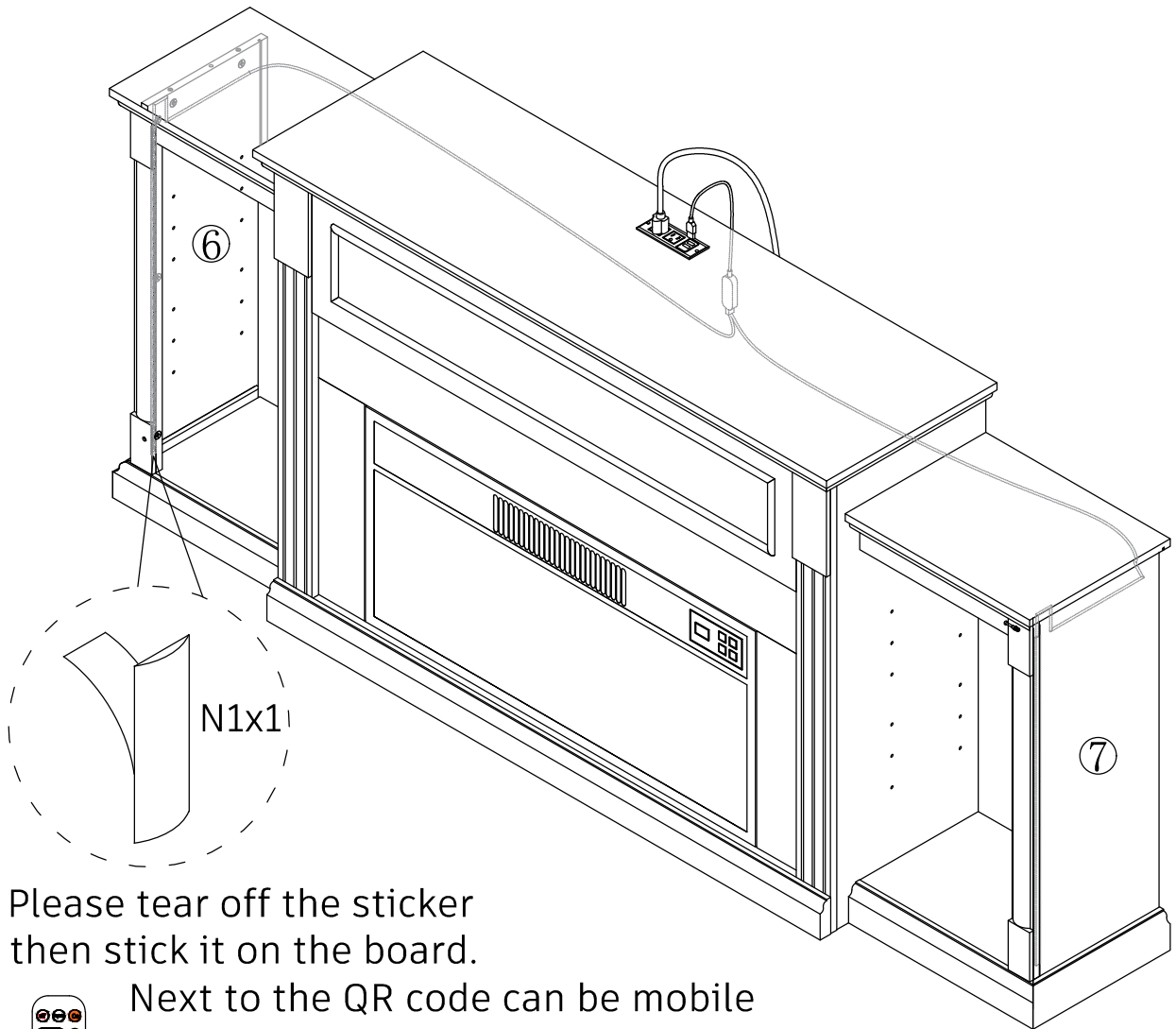

Please tear off the sticker then stick it on the board.



Next to the QR code can be mobile phone remote control light belt, please give priority to use mobile phone control.

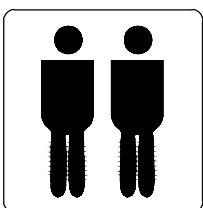

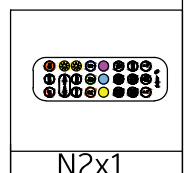
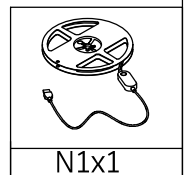

This step require two people to be completed.

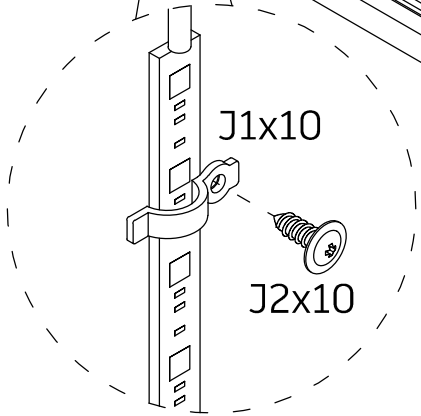
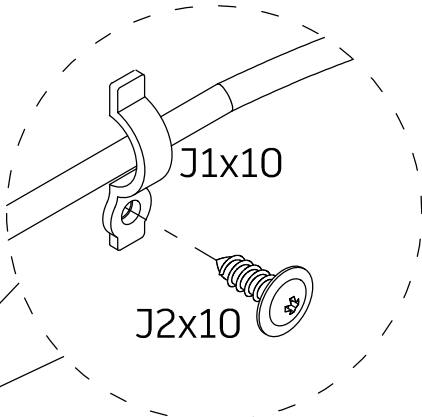
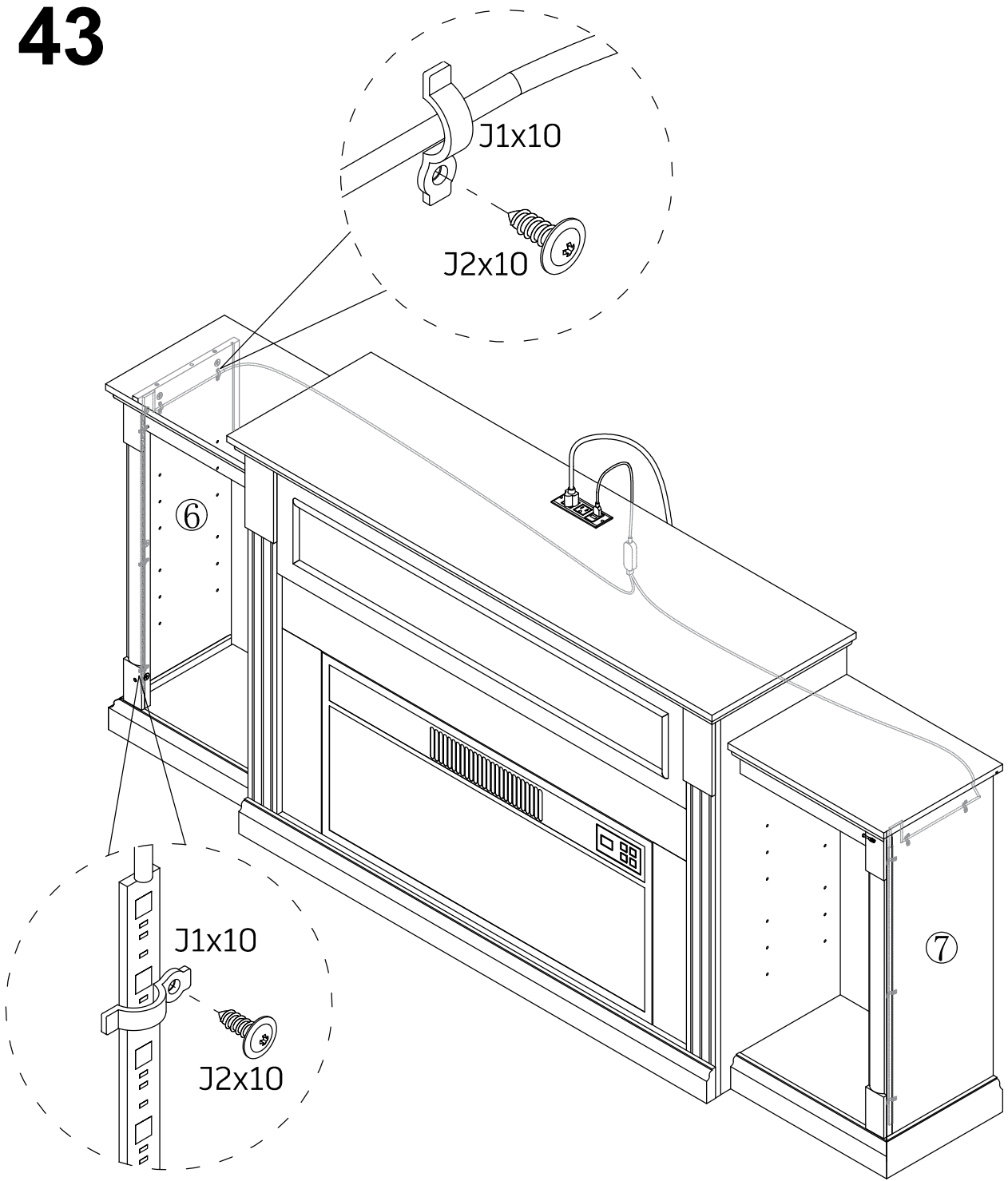

Note: If you encounter any issues, please contact customer service.

43



J1x10

J2x10

Note: If you encounter any issues, please contact customer service.

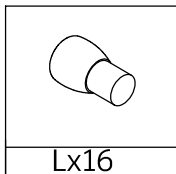
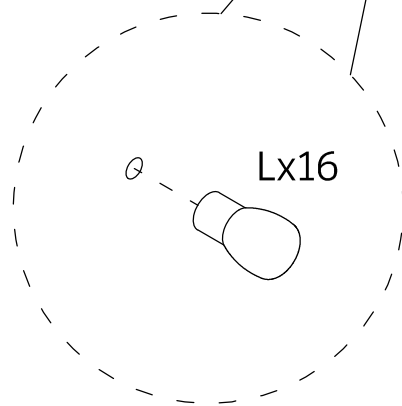
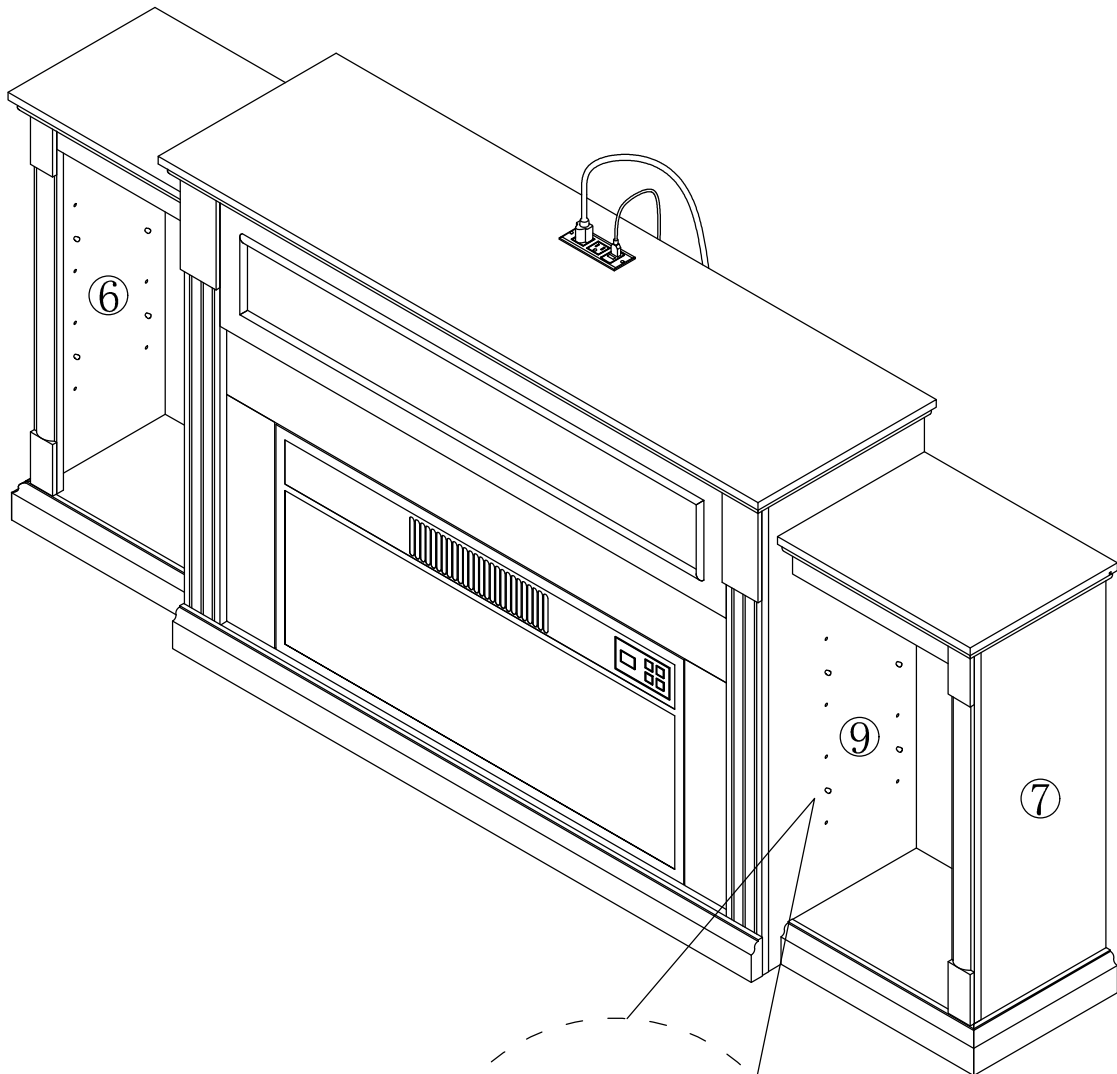
44



Note: If you encounter any issues, please contact customer service.

45

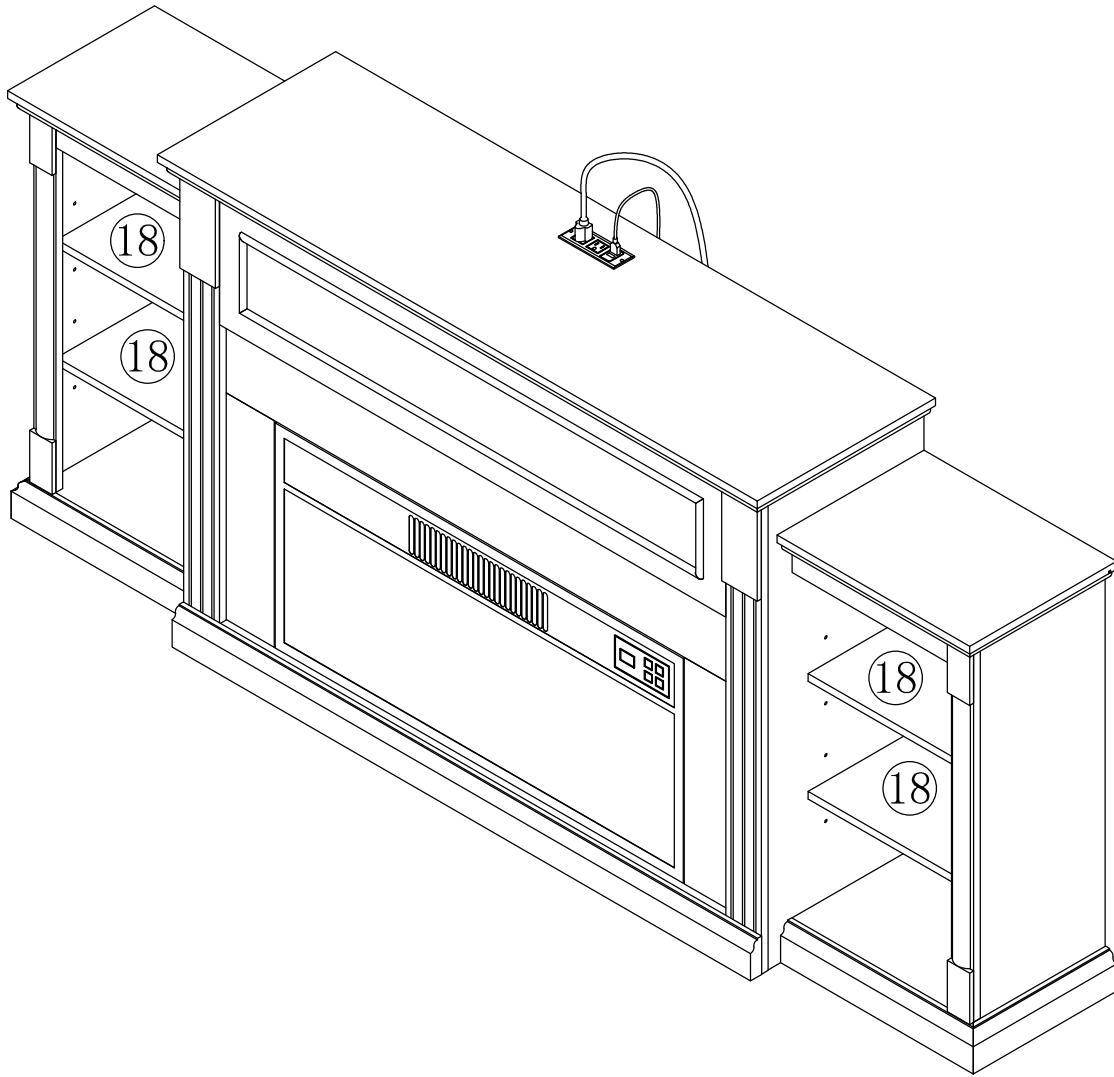

Note: If you encounter any issues, please contact customer service.

46

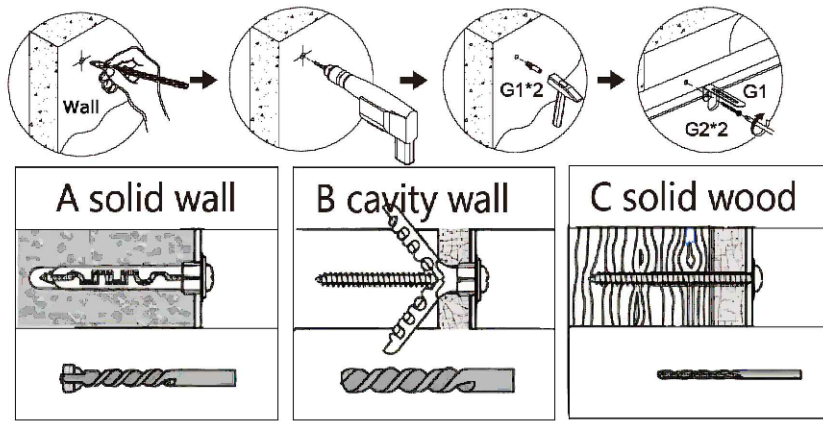

- Warning:** If you overturn the furniture, it may cause serious or fatal crushing injuries. We have a wall connection device attached, please use it to hold the furniture following these instructions.
1. Mark the corresponding hole positions where you want to place the furniture;
 2. Use an impact drill to drill holes and pay attention to avoid wires and water pipes;
 3. Knock the expansion pipes into the wall holes;
 4. Place the furniture in the corresponding position and tighten the wall connection device with screws.

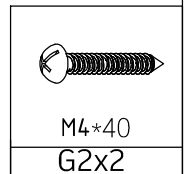
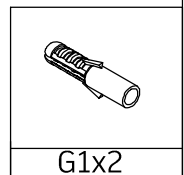
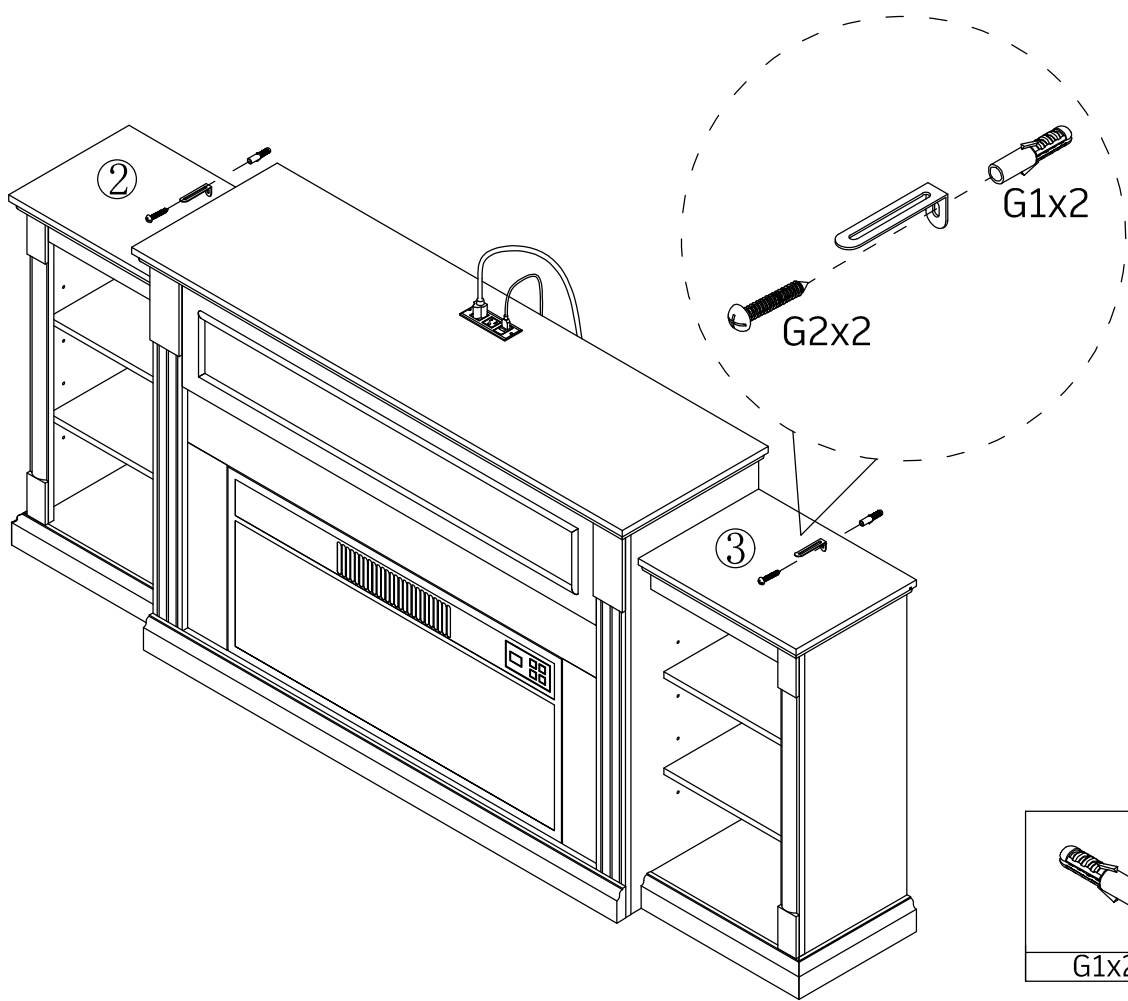

Note: If you encounter any issues, please contact customer service.