

- | | | | |
|------|-----------------------------|------|-------------------------|
| (D) | Montageanleitung | (GB) | Assembly instructions |
| (FR) | Notice de montage | (IT) | Istruzioni di montaggio |
| (NL) | Handleiding voor de montage | (PL) | Instrukcja montażu |
| (CZ) | Montážní návod | (SK) | Návod na montáž |
| (HU) | Szerelési útmutató | (RO) | Instrucțiuni de montaj |
| (TR) | Montaj talimatı | (RU) | Инструкция по монтажу |

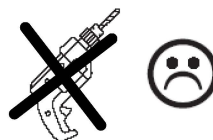
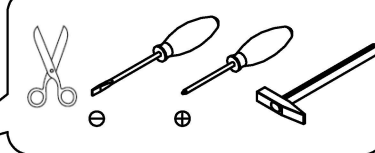
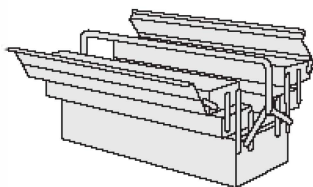
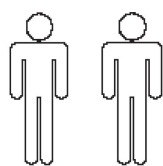

0
10
20
30
40
50
60
70
80
90
100
110
120
130
140
150
160
170
180
190
200

Service • Dienstverlening • Serwis • Servis • Сервисная служба

Name • Naam • Nazwa • İsim • Название	
Nr. • No. • Номер	
Typ • Type • Тип • Тип	

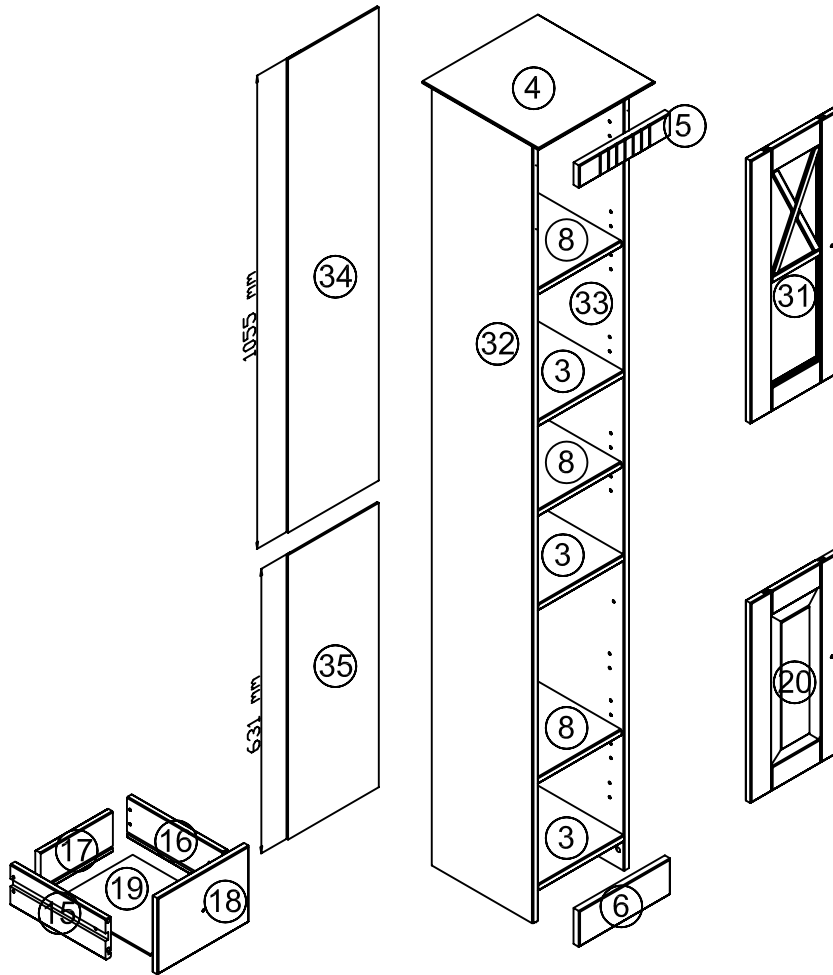

A Ø8x30mm 28x 	B Ø6.5x34mm 16x 	C Ø15x11mm 16x 	D 4mm 1x 	E Ø5x16mm 12x 	F 20x1.2mm 50x 	G Ø4x30mm 4x 	H 20x20x16mm 1x 	I Ø4x60mm 1x 	
J Ø3.5x15mm 9x 	K 22x22mm 4x 	L Ø12x18mm 4x 	M 245mm 2x 	N D Leim GB Glue NL Lijm PL Klej TR Tutkal RU Клей 1x 	O M4x10mm 2x 	P Ø5.8x9mm 4x 	R Ø28x29mm 3x 	S Ø26mm 4x 	
T 36x52mm 4x 	U Ø3.5x35mm 7x 	UV 45x18mm 1x 							

1

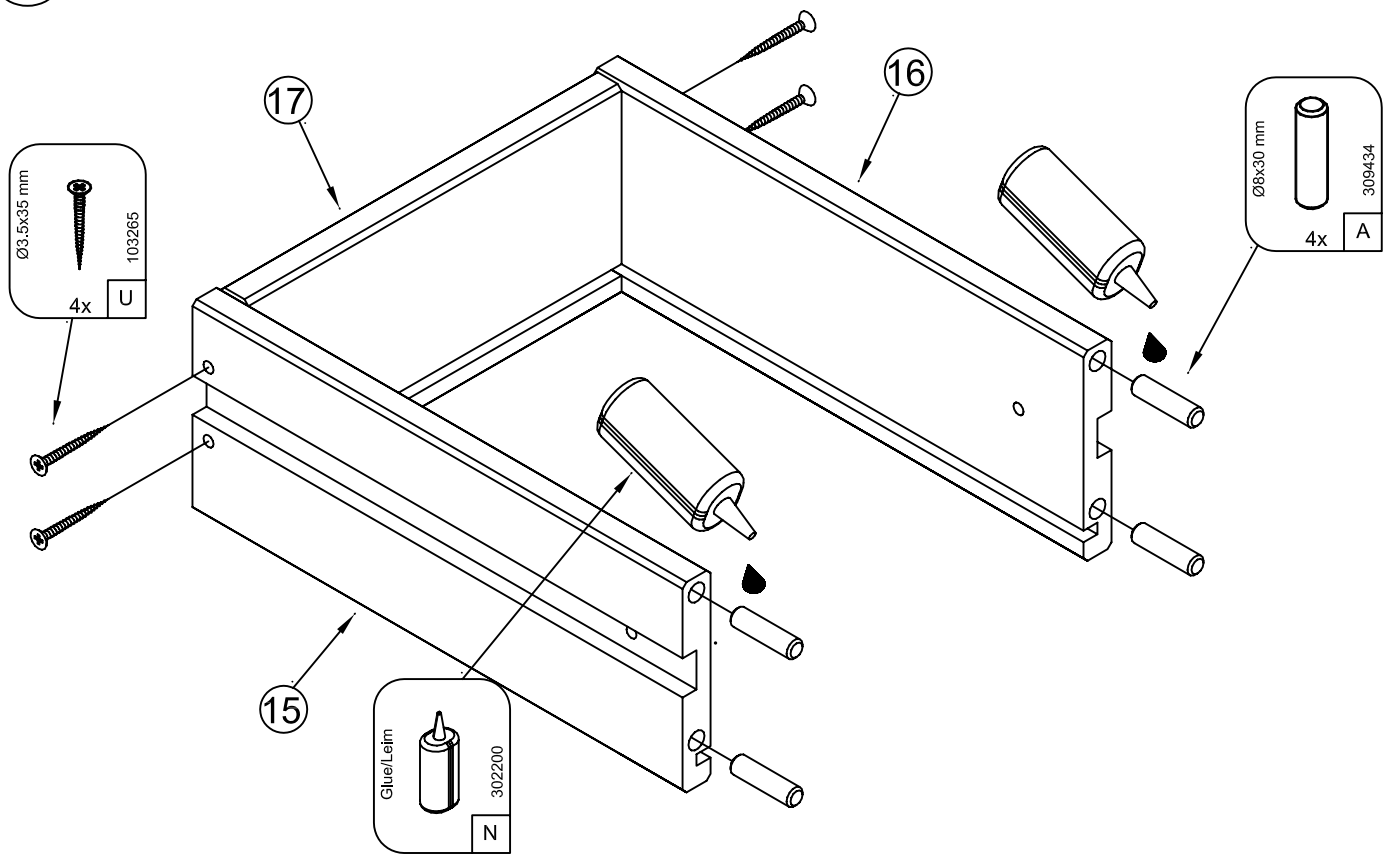

2

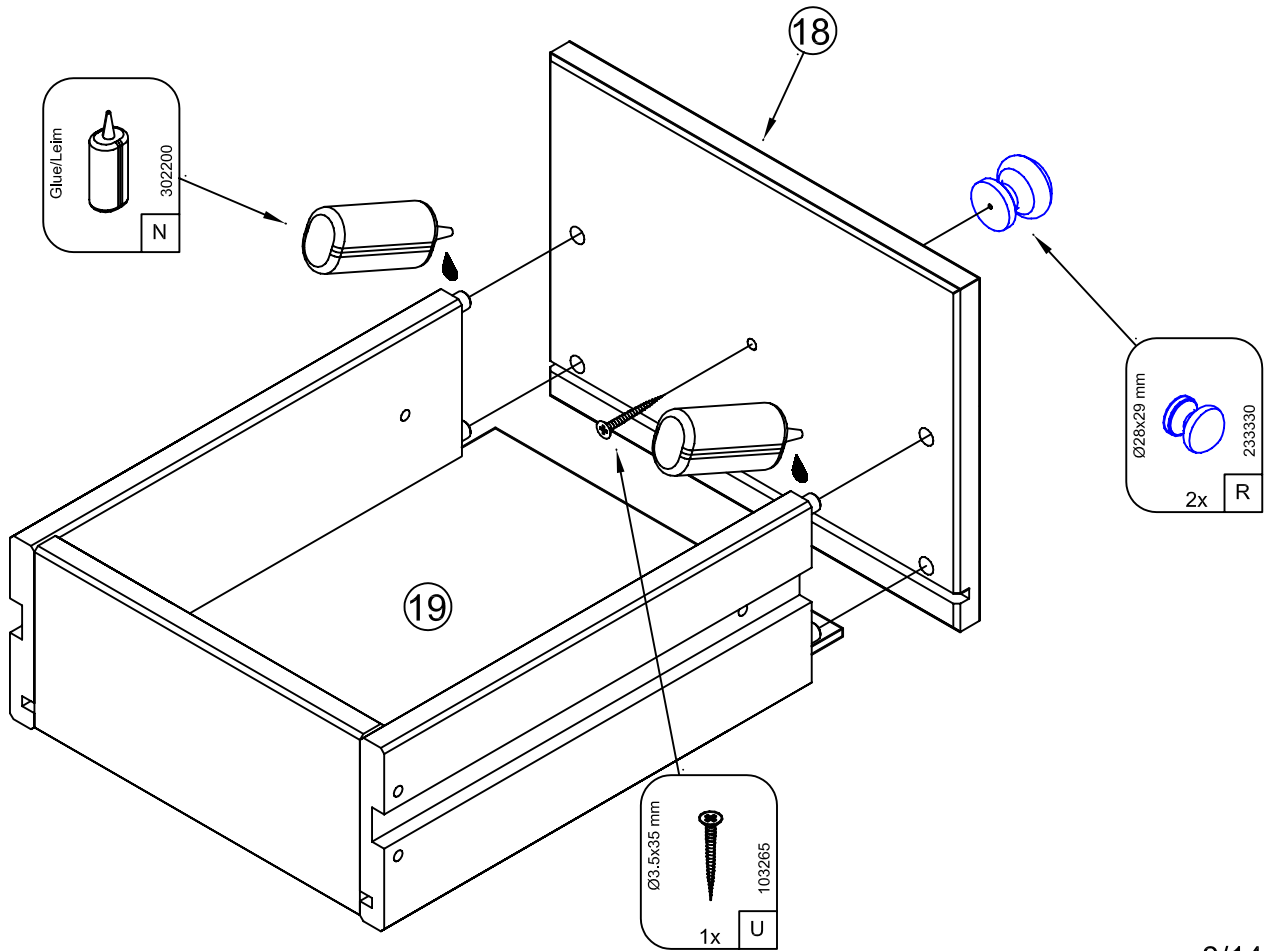

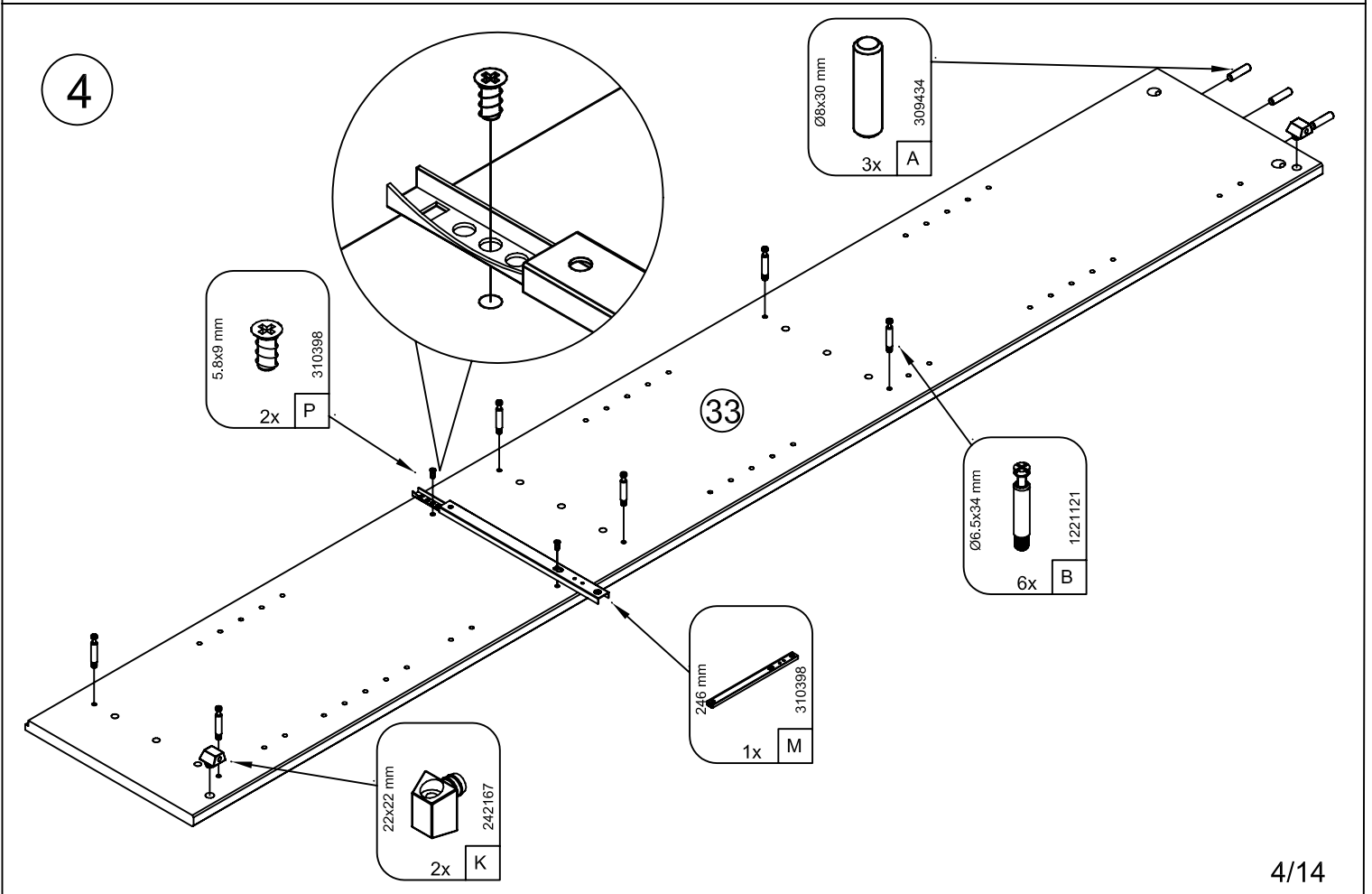
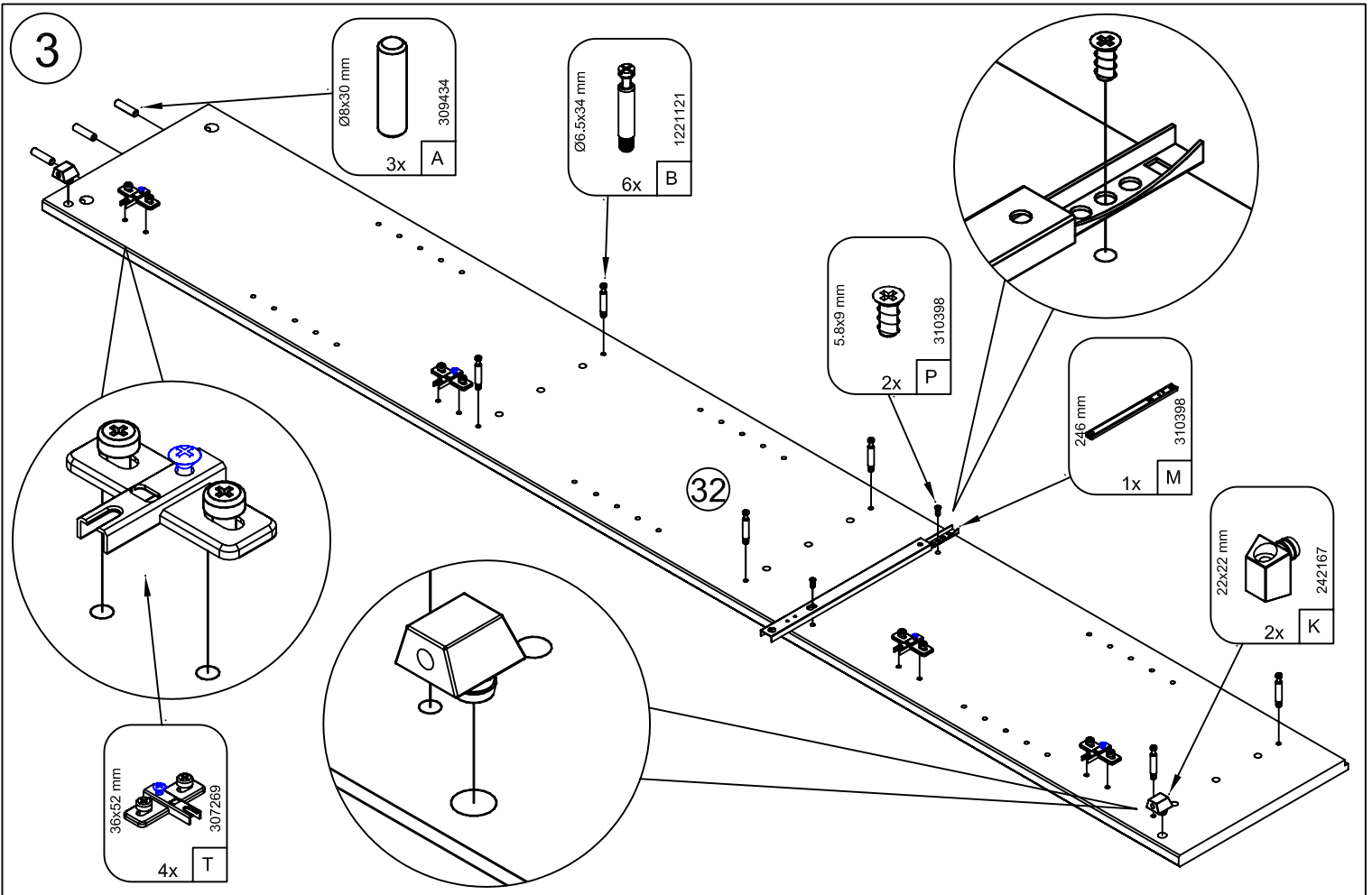

5

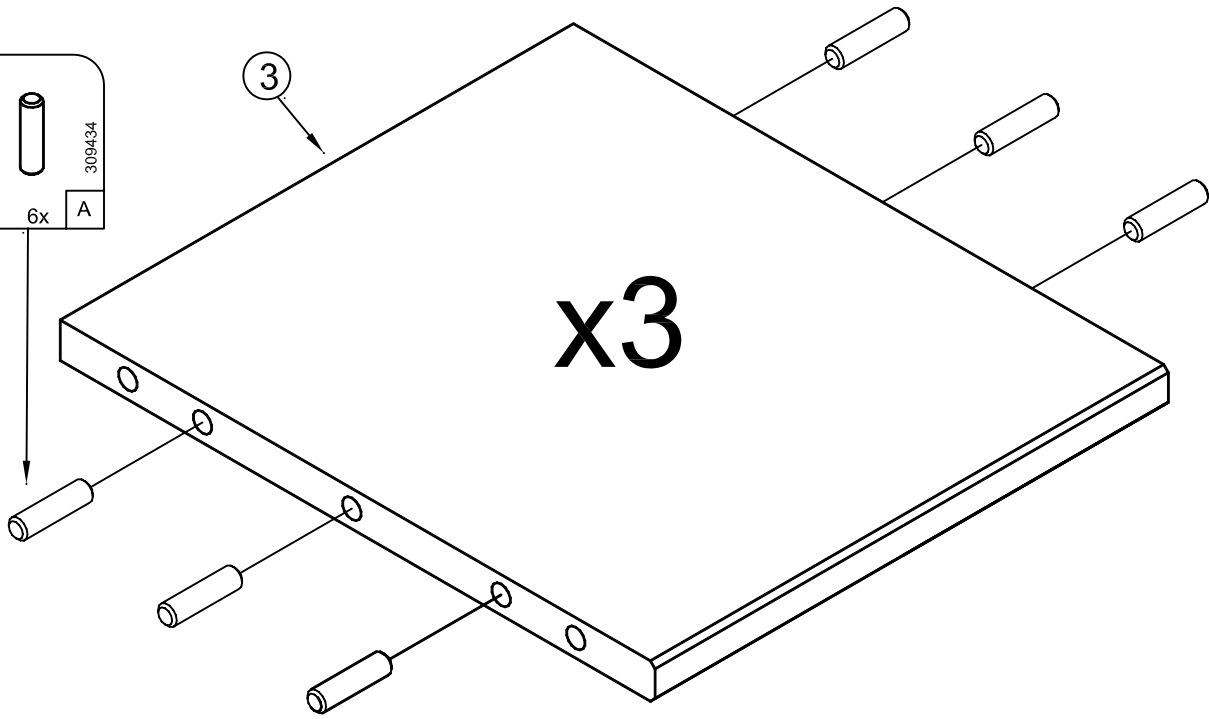
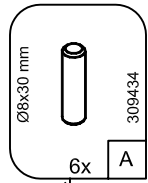

6

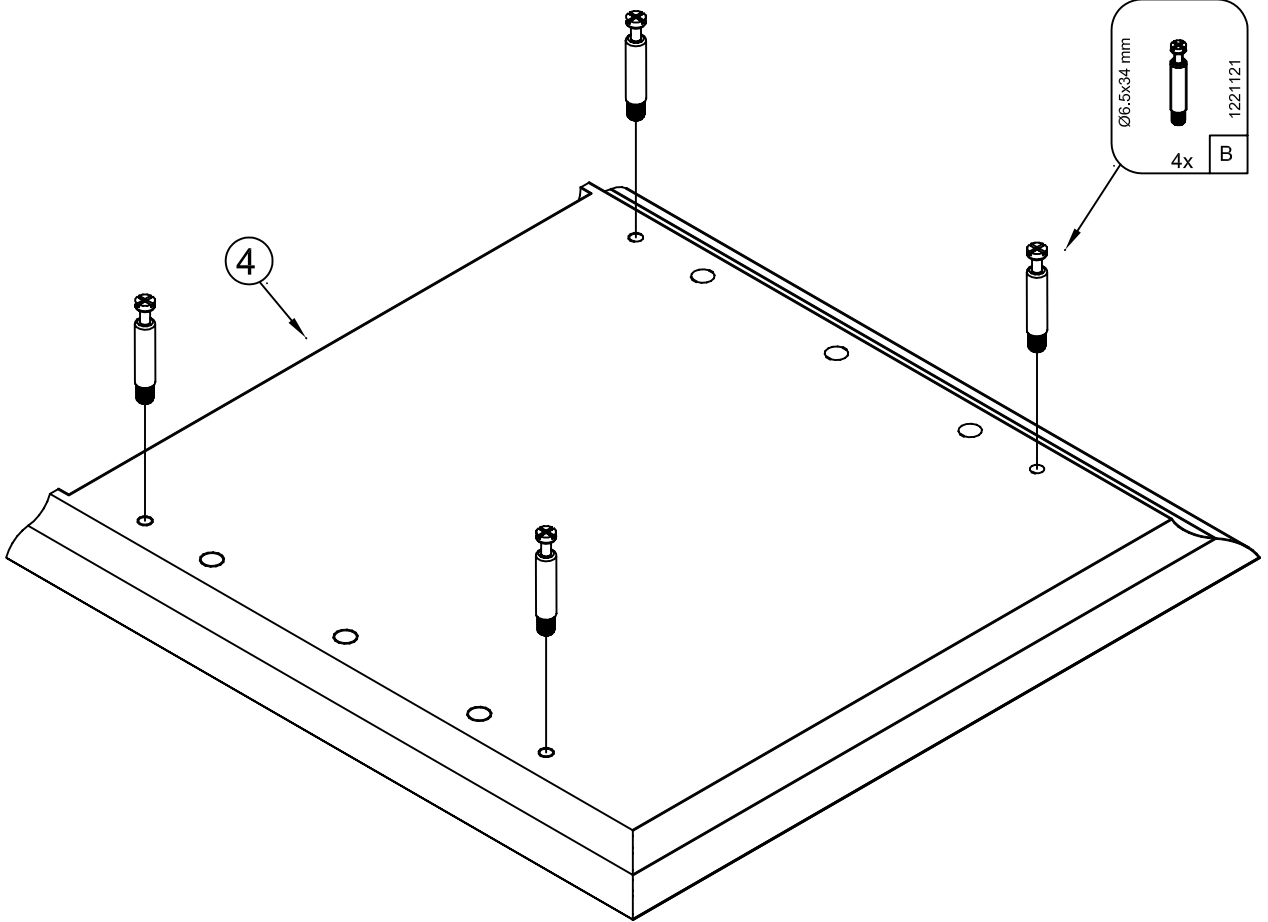
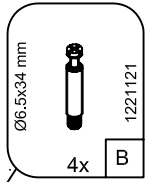

7

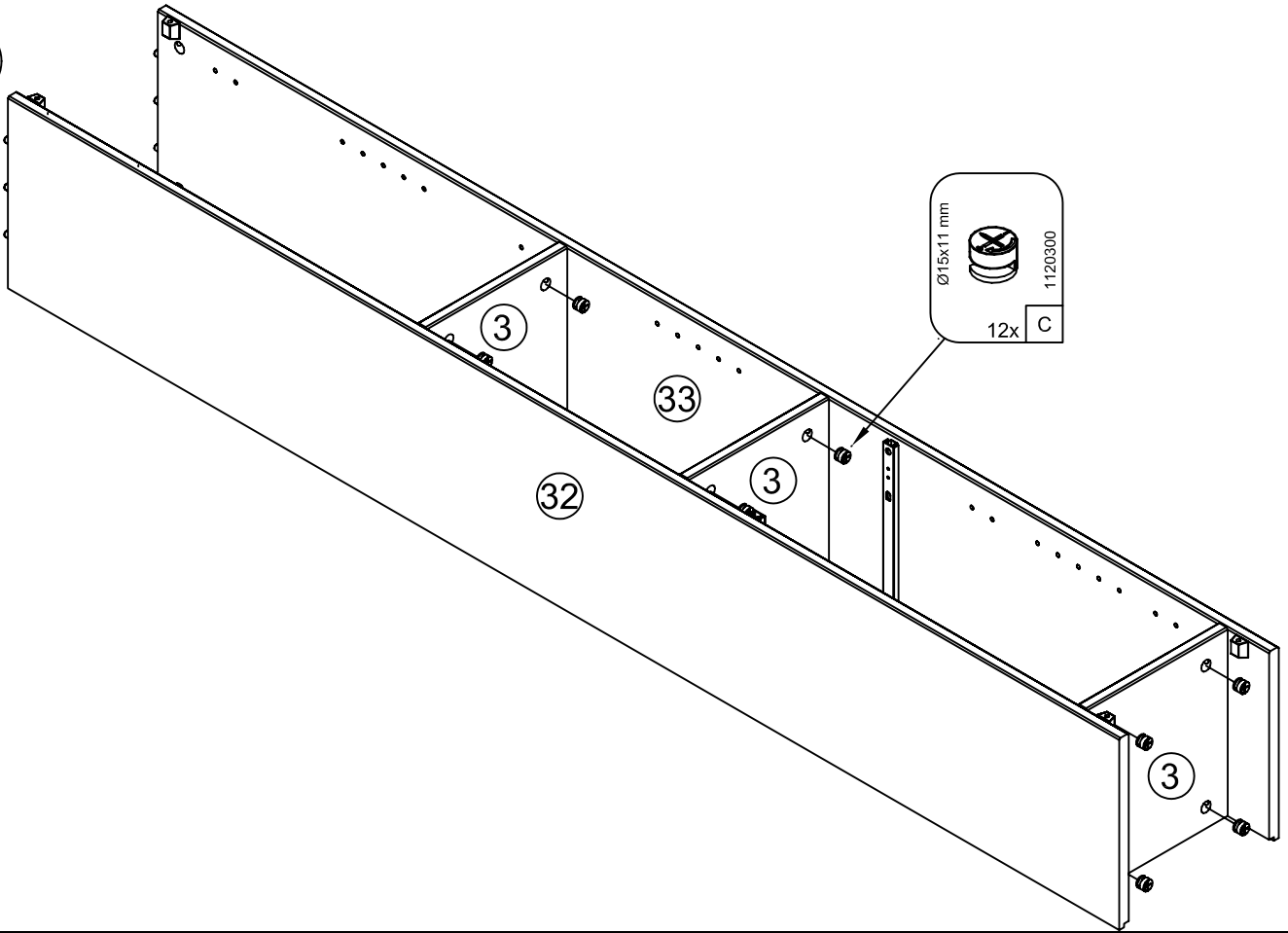

8

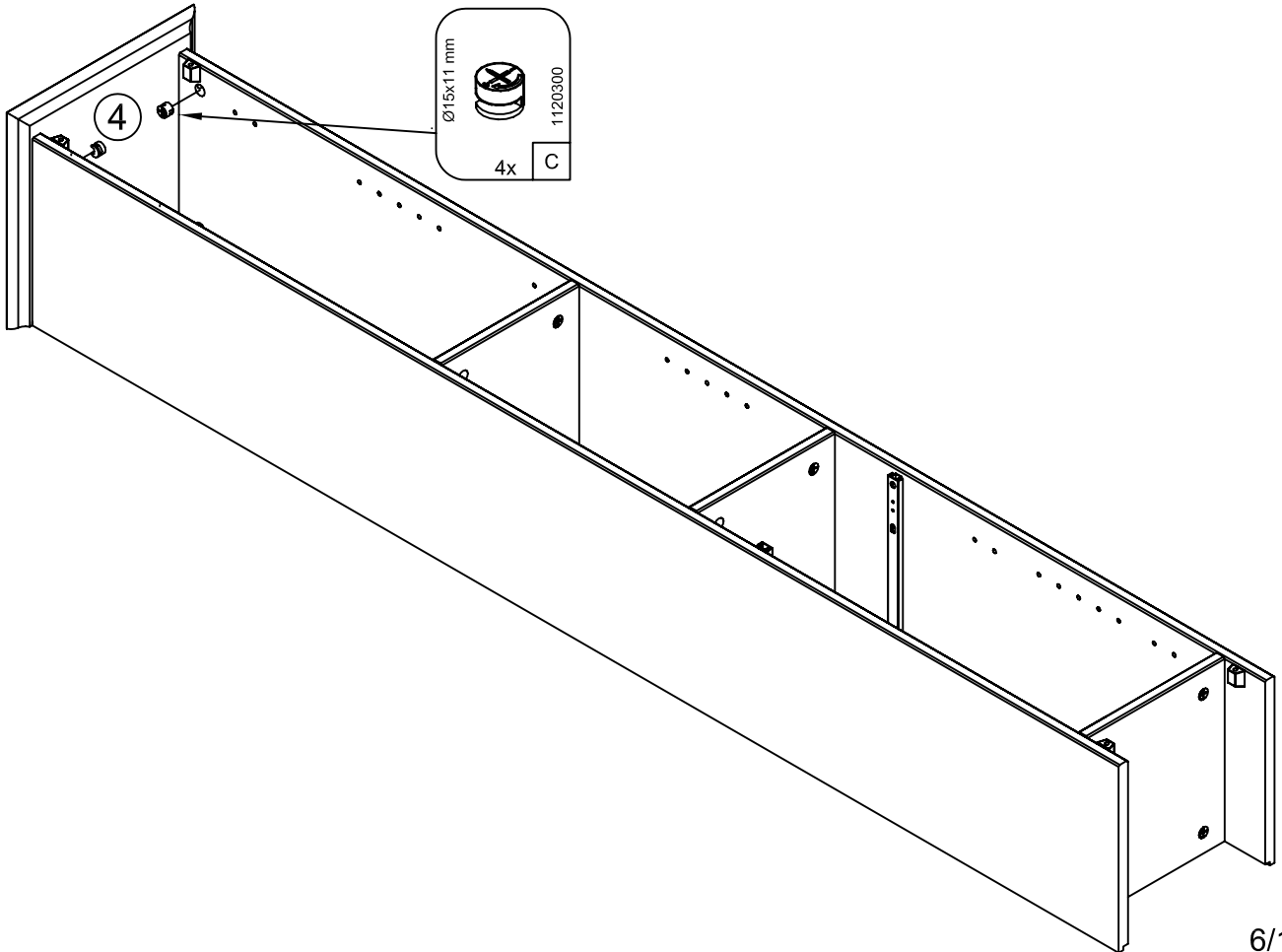

9

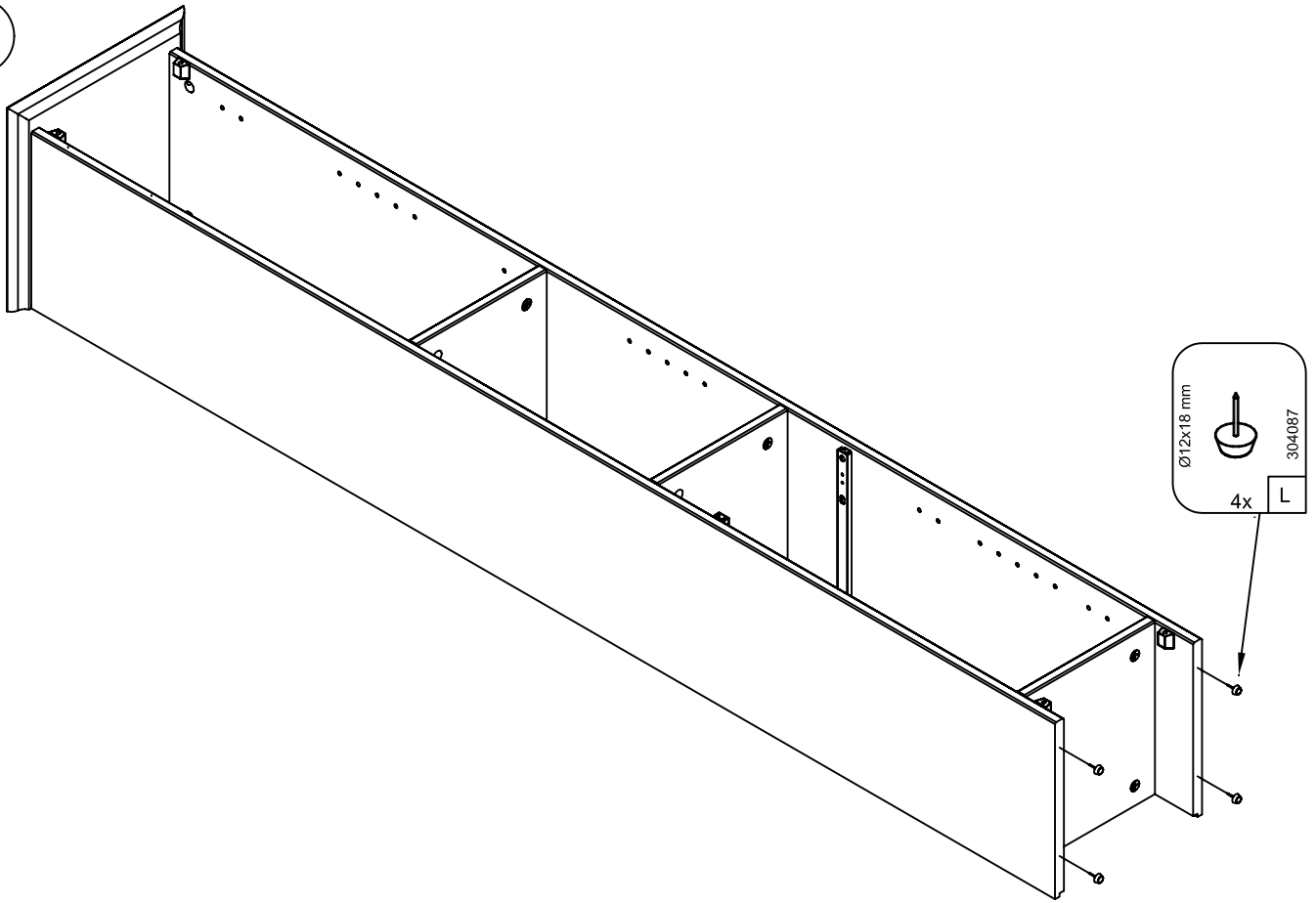

10

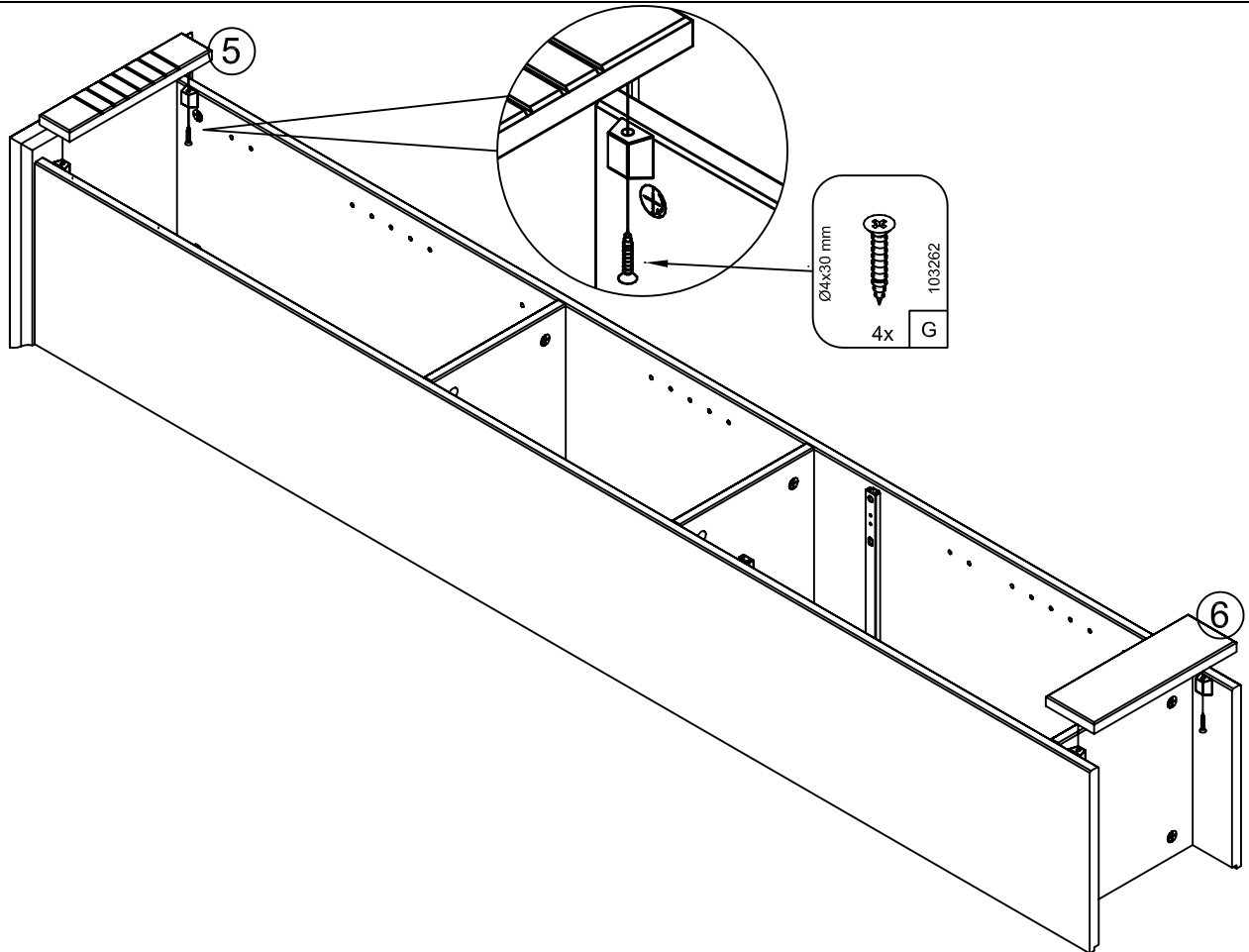

11

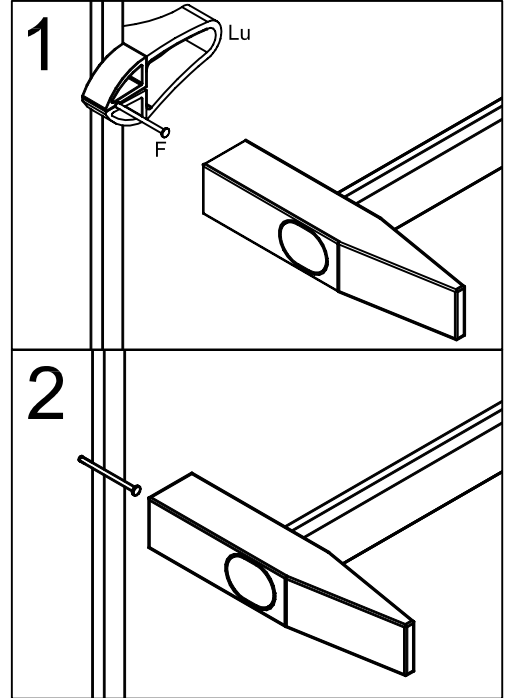
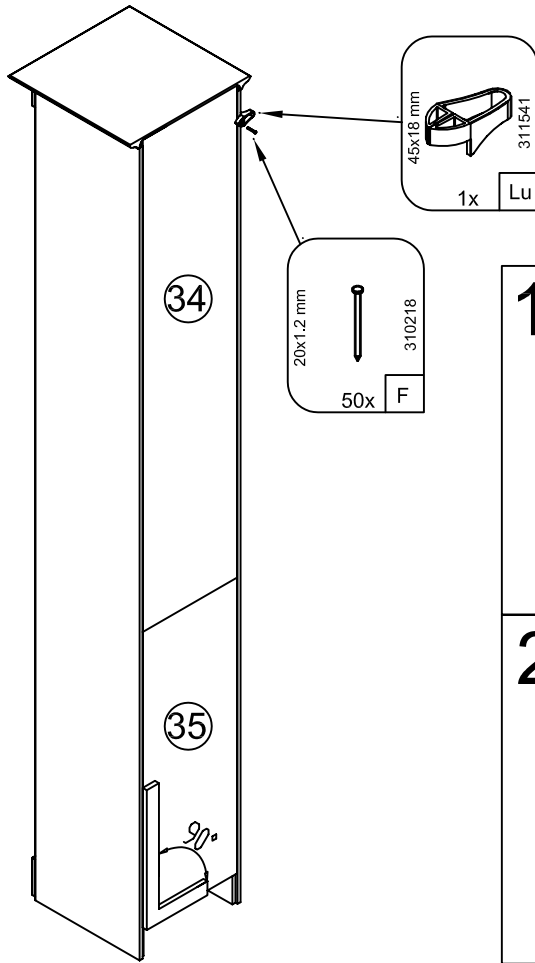

12

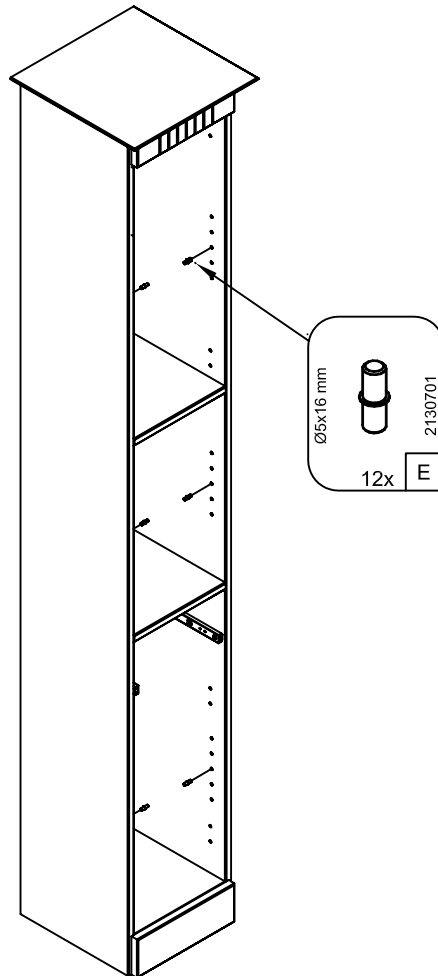

13

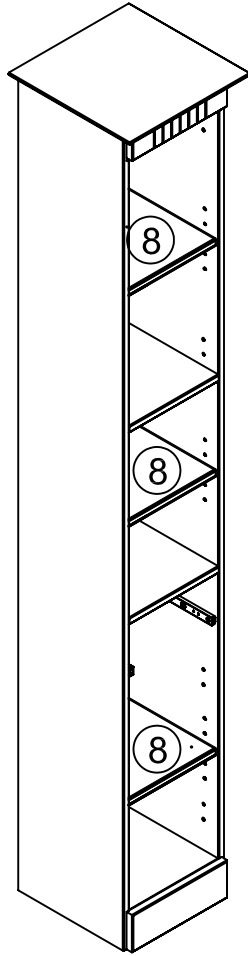

14

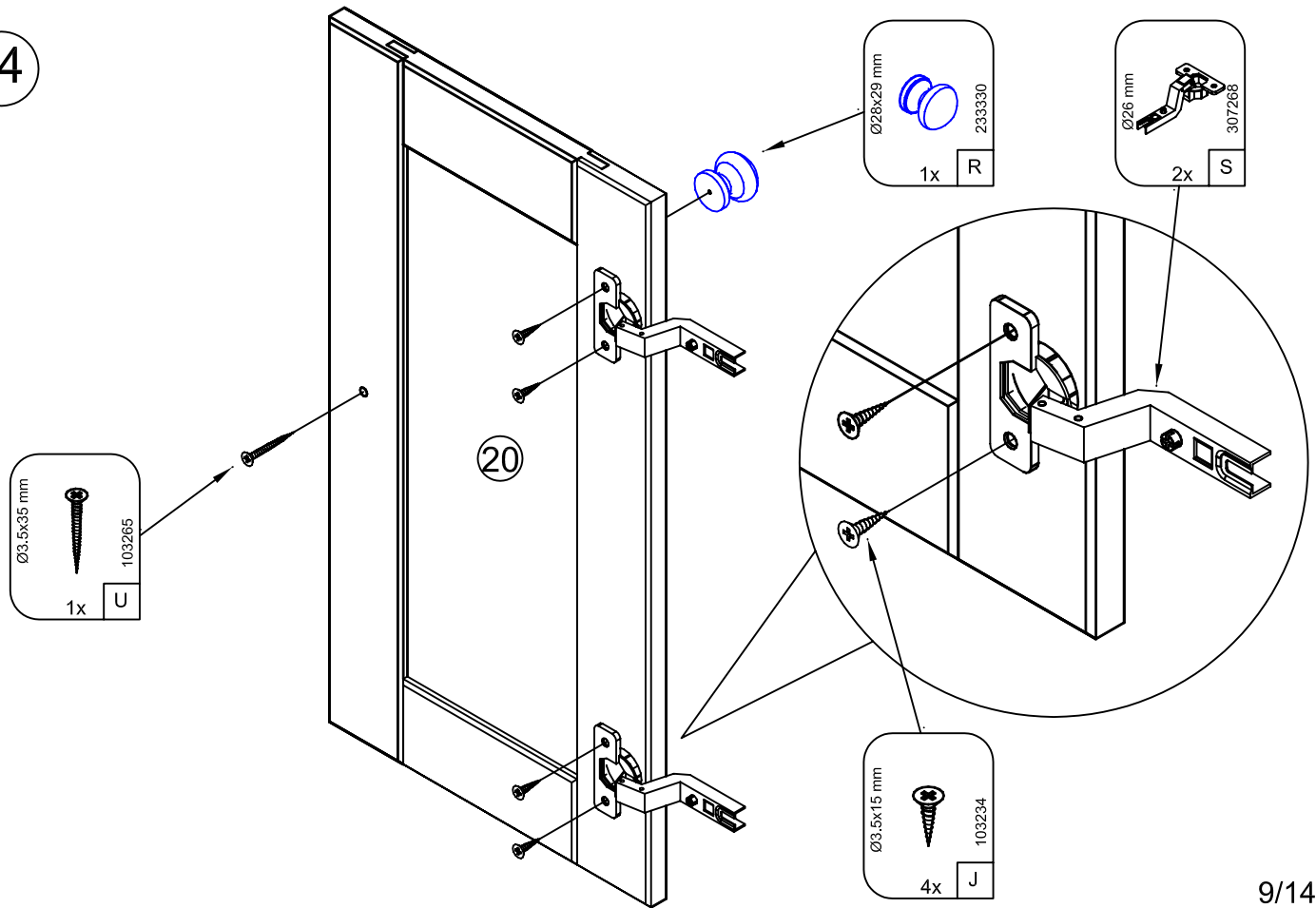

15

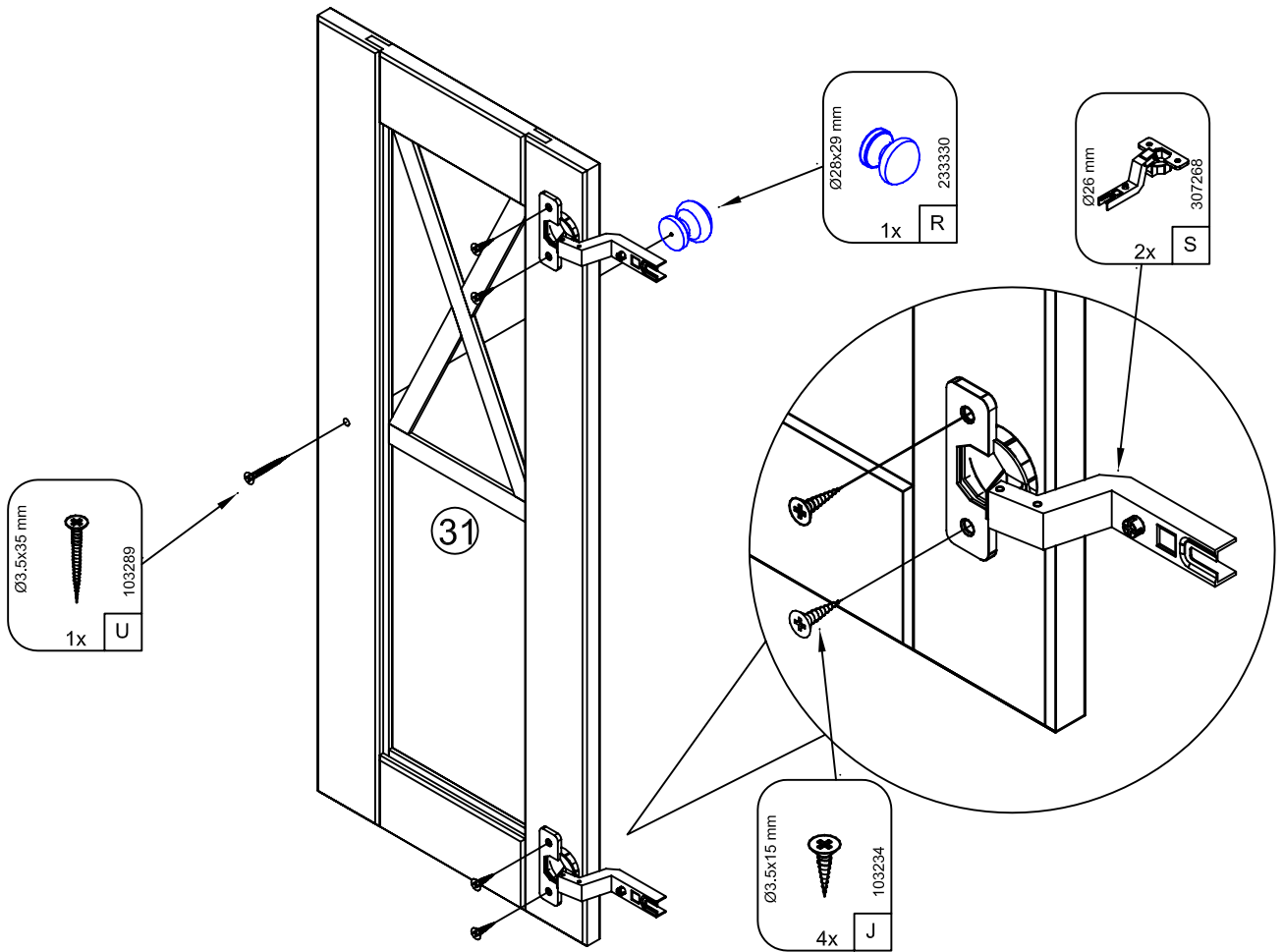

16

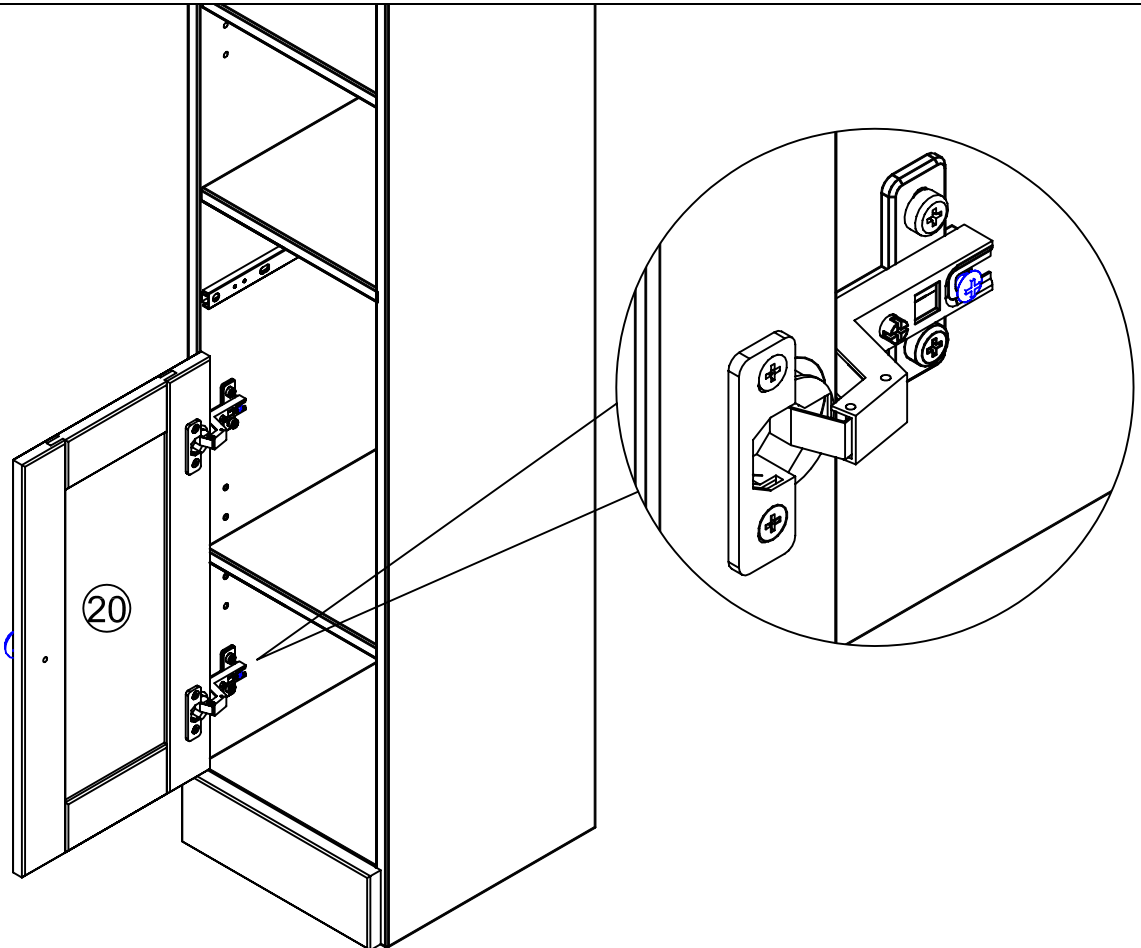

17

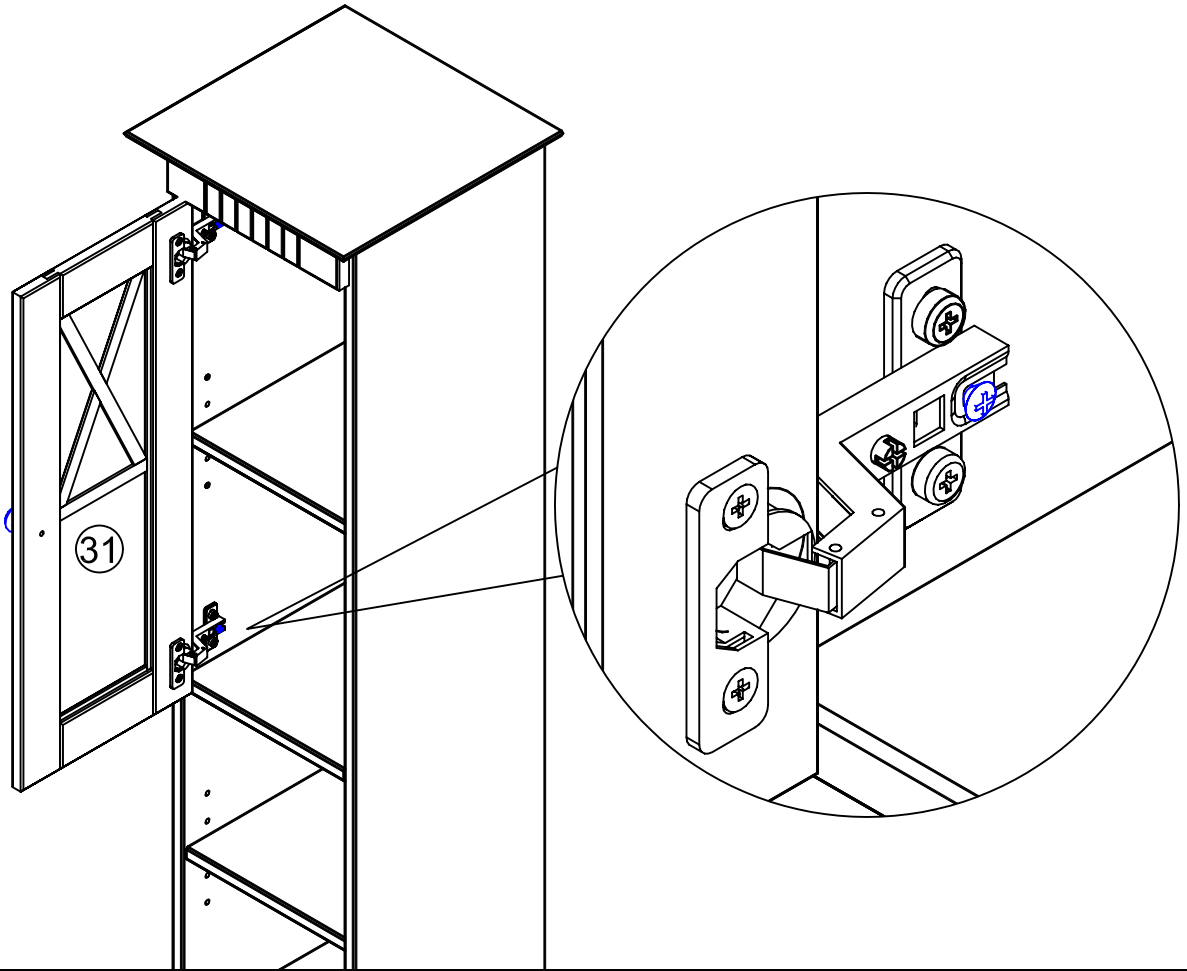

18

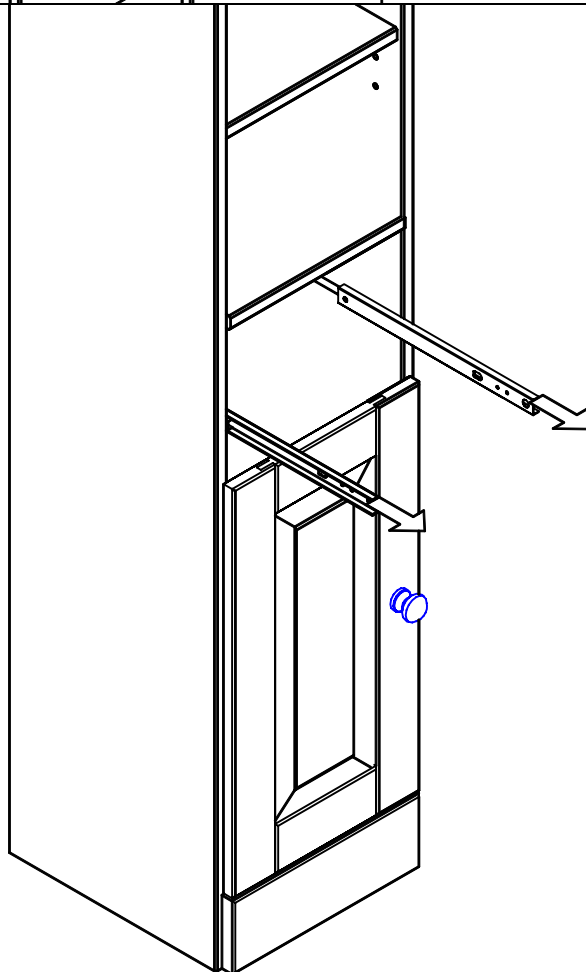

19

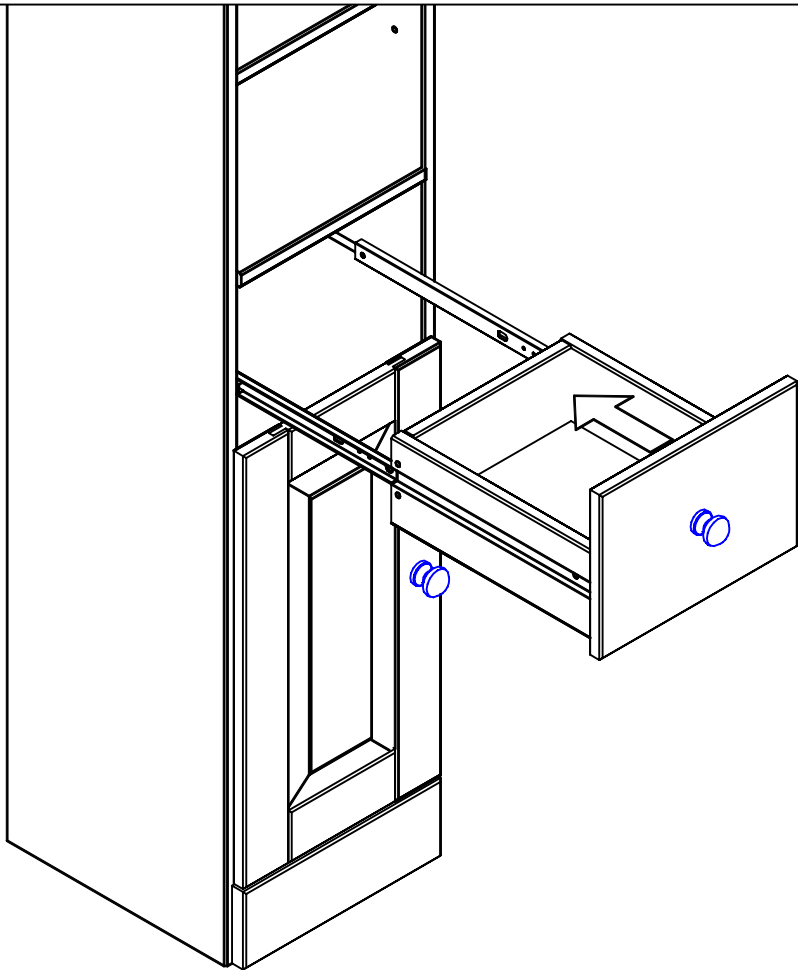

20

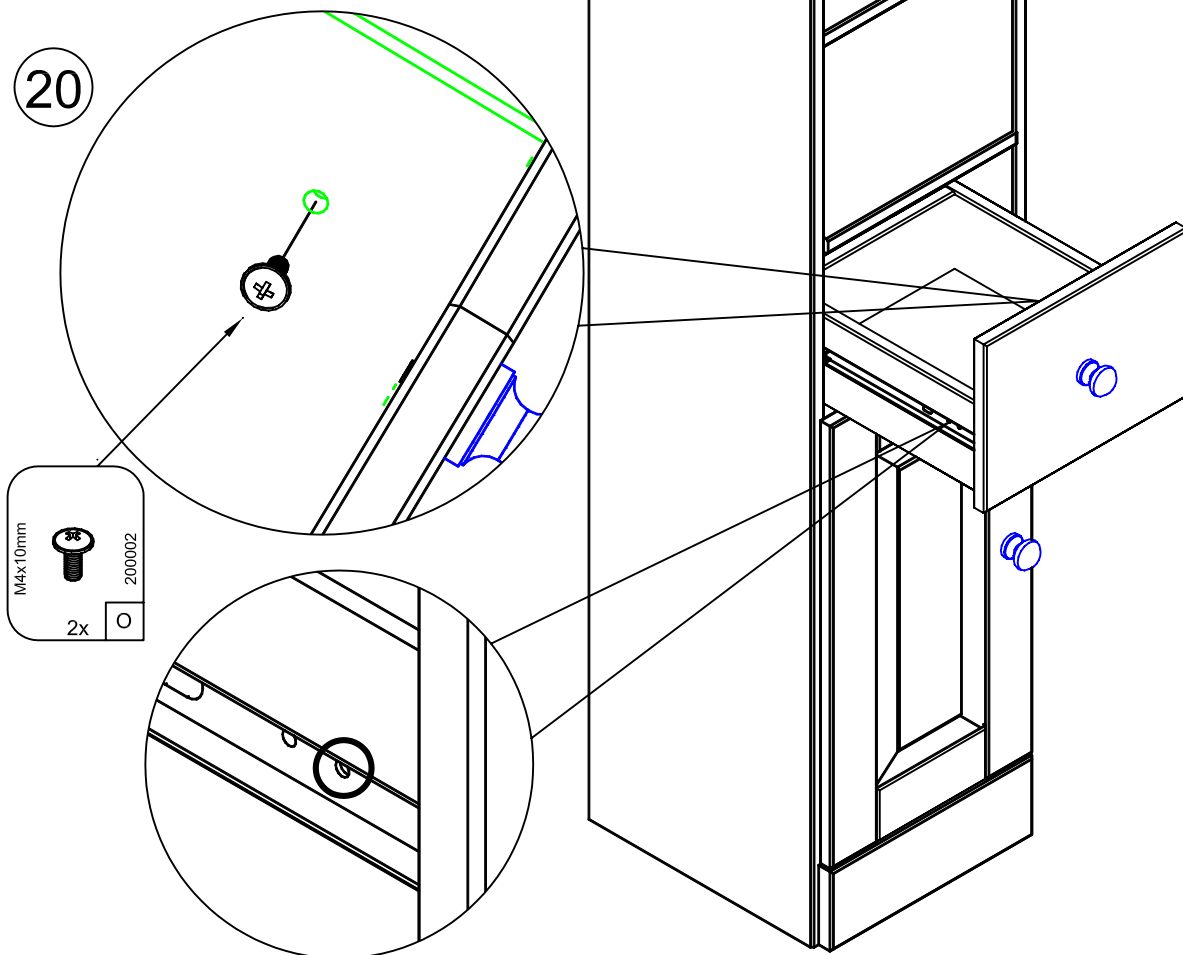

21

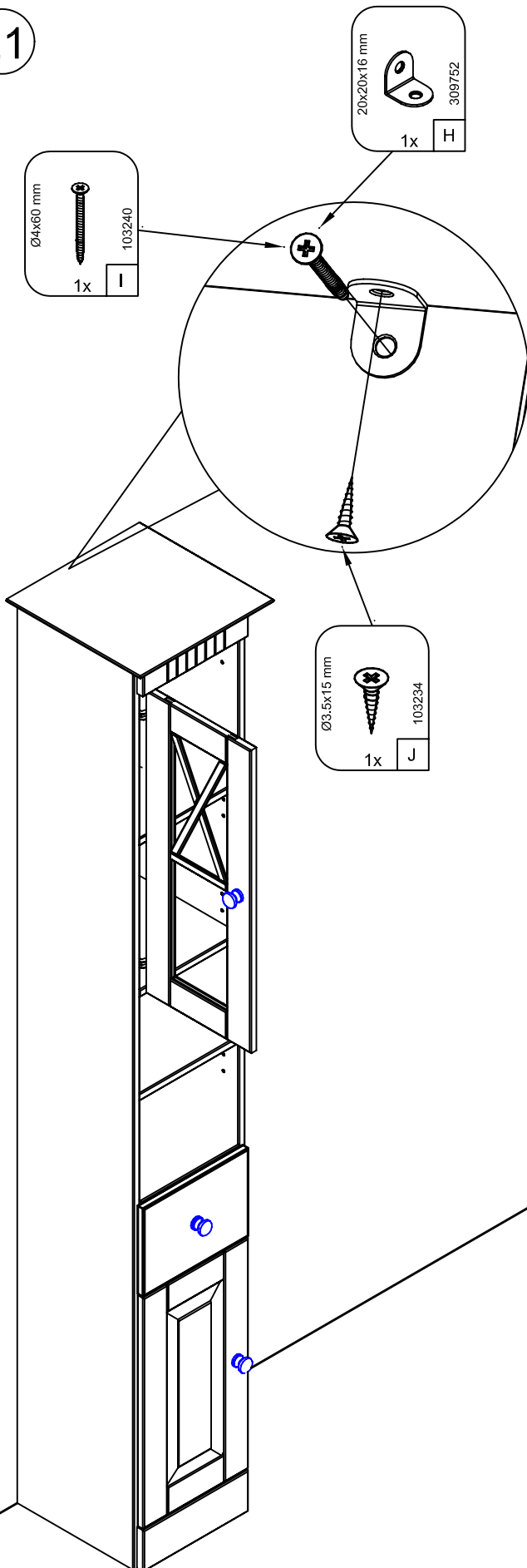

**Achtung • Attention • Attenzione
Opgelet • Uwaga • Pozor • Figyelem
Atenție • Dikkat • ВНИМАНИЕ**

(D)	Wandbefestigung dient als Kippschutz – unbedingt anbringen! Bei einigen Wandtypen kann ein Spezialdübel erforderlich sein!
(GB)	The wall fastening serves to prevent tipping – be absolutely sure to mount it! For certain wall types, a special wall plug may be necessary!
(FR)	La fixation murale sert de protection contre le basculement – à installer impérativement ! Pour certains types de murs il faut des chevilles spéciales !
(IT)	Il fissaggio alla parete serve da protezione anti-ribaltamento – attaccarla assolutamente! Per alcune strutture di parete può essere necessario un tassello speciale!
(NL)	Bevestiging aan de muur dient als kantelbescherming – zeker en vast bevestigen! Bij enkele muurtypes is een speciale plug misschien vereist!
(PL)	Mocowanie do ściany jest jednocześnie zabezpieczeniem przed przewróceniem – koniecznie zamontować! Do niektórych rodzajów ścian koniecznie zastosować specjalne kołki mocujące.
(CZ)	Montáž na stěnu slouží jako ochrana proti převrnutí – bezpodmínečně umístěte! U některých typů stěn může být zapotřebí speciální hmoždinka!
(SK)	Upevnenie na stenu slúži ako ochrana proti prevráteniu – bezpodmienenčne použite! Pre niektoré druhy stien môže byť potrebná špeciálna hmoždinka!
(HU)	A terméket a falhoz kel rögzíténi, különben az felborulhat! Egyes faltípusoknál speciális tiplit kell használni!
(RO)	Sistemul de fixare la perete servește ca protecție la răsturnare – de montat obligatoriu! Pentru unele tipuri de pereți este posibil să fie necesar un diblu special!
(TR)	Duvardaki sabitleme, devrilmeye karşı bir emniyet tedbidir ve mutlaka monte edilmelidir! Bazı duvar tiplerinde bunun için özel bir dübel gerekli olabilir!
(RU)	Обязательно установите крепление на стене во избежание опрокидывания! Для некоторых типов стен может потребоваться специальный дюбель!

22

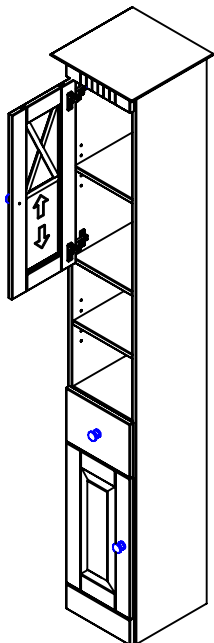

Türen einstellen (Scharniere justieren)
 Adjusting the doors (adjusting the hinges)
 Régler les portes (ajuster les charnières)
 Sistemare le porte (regolare le cerniere)
 Deuren instellen (scharnieren afstellen)
 Nastawić drzwi (wyregulować zawiasy)

Vyrovnejte dvířka (seříd'te závěsy)
 Nastavenie dverí (nastavenie závesov)
 Állítsa be az ajtókat (állítsa be a zsanérokát)
 Reglare uși (ajustare balamale)
 Kapıların ayarlanması (menteşelerin seviye ayarı)
 Регулировка дверей (регулировка шарнира)

