



# Assembly Instructions

 Before you throw the carton, please ensure that you have all the parts needed for the assembly.

 **Hardware Note:**  
1. For each step please don't fully tighten all the screws at first, when they all align to the holes you can fully tighten them.  
2. All the bolts should be assembled **vertically** to the holes.

 **Spare parts** can be found in the hardware box if you do not have enough bolts for assembly.

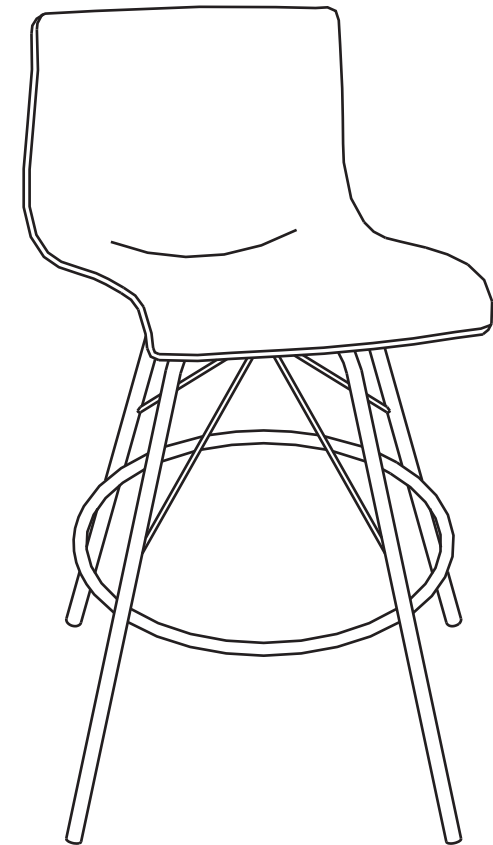
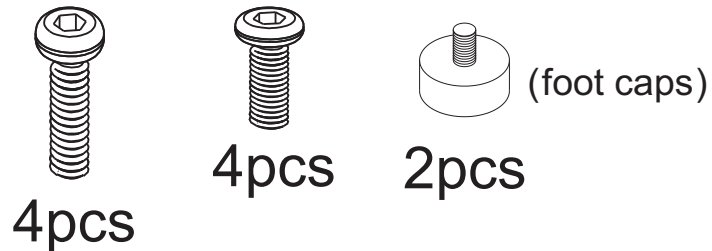

 THIS INSTRUCTION BOOKLET CONTAINS IMPORTANT SAFETY INFORMATION. PLEASE READ AND KEEP FOR FUTURE REFERENCE.

# Assembly Instructions

## Parts and Hardware

Please check to make sure you have all parts and hardware before starting assembly process.

(A)

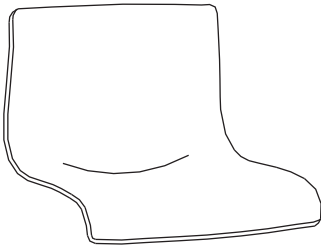

Seat 4pcs

(B)

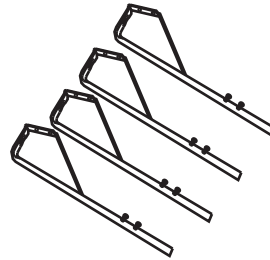

Legs 16pcs

(C)

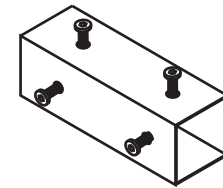

Connecting Tube 4pcs

(D)

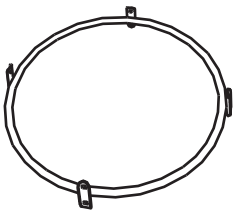

Connecting Circle 4pcs

(E)



Bolts 16pcs

(F)

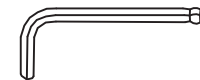

Wrench 1pc

# Assembly Instructions

## Assembly Instructions

STEP 1: Remove the bolts from the connecting tube and legs.  
(total 16pcs)

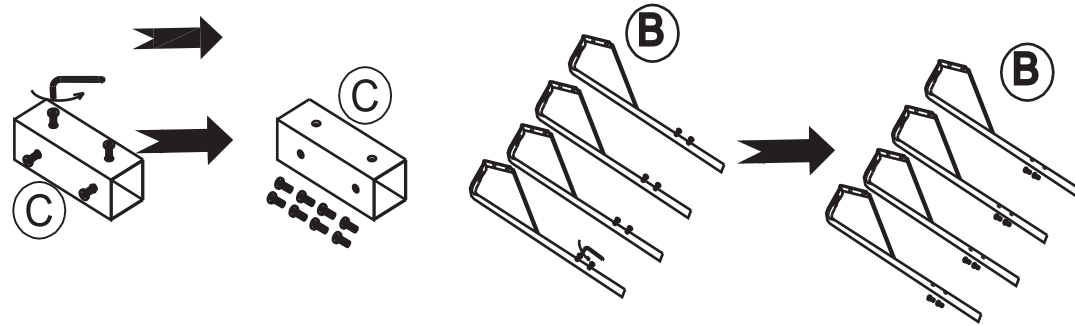

STEP 2: Use the bolts remove from the tube to connect legs and connecting tube. Screw the bolts by hand about 3 turns.

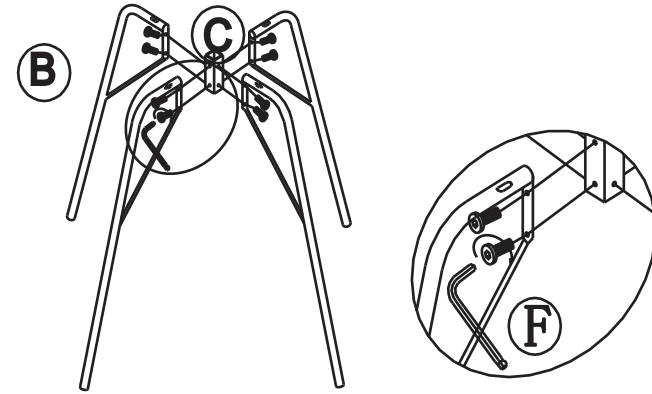

STEP 3: Please make sure you know the difference between the upper and lower side of connecting circle when you assemble it to legs.

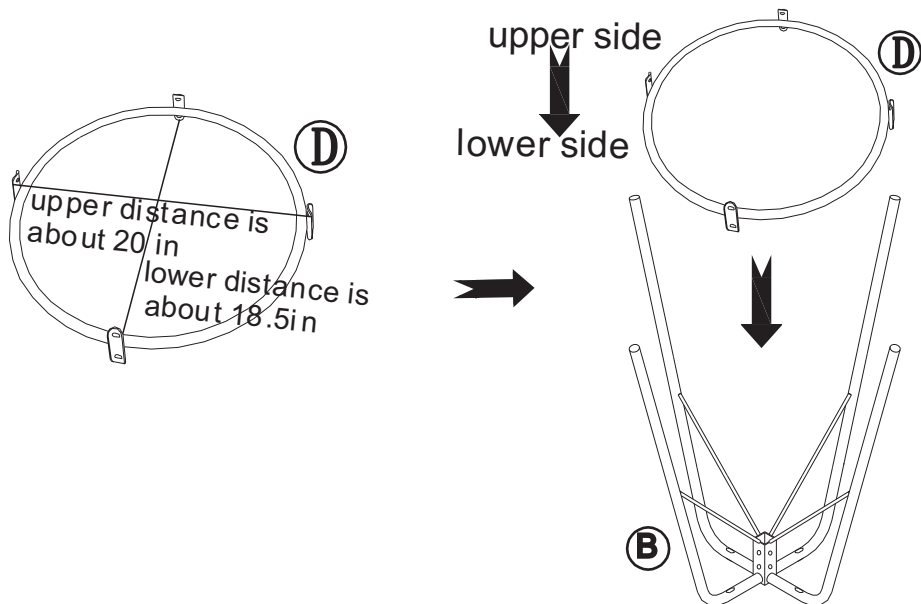

STEP 4: Connect the leg to seat use the bolts remove from legs. Turn the bolts by hand about 3 turns.

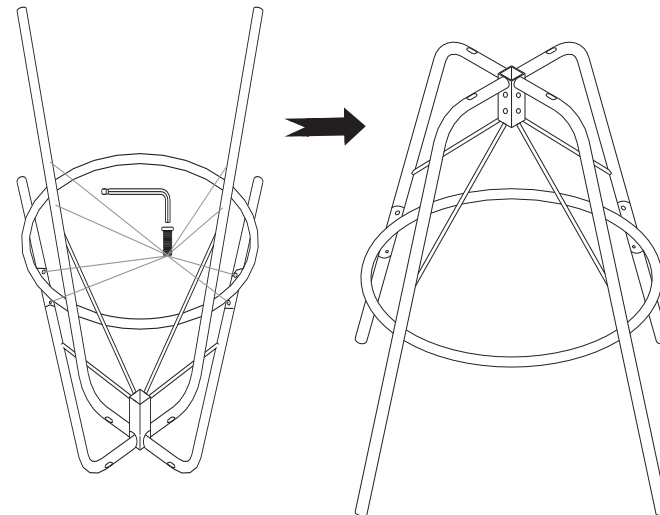

# Assembly Instructions

## Assembly Instructions

STEP 5: Put seat on a soft and flat place(see diagram 1). Connect assembled legs to the swivel on the bottom of seat. Screw the bolts by hand about 3 turns, Put pre-assembled chair on a flat place(see diagram 2) and adjust four legs foot caps until the chair is steady, tighten all bolts by the short side of wrench.

