

BED FRAME

QUEEN

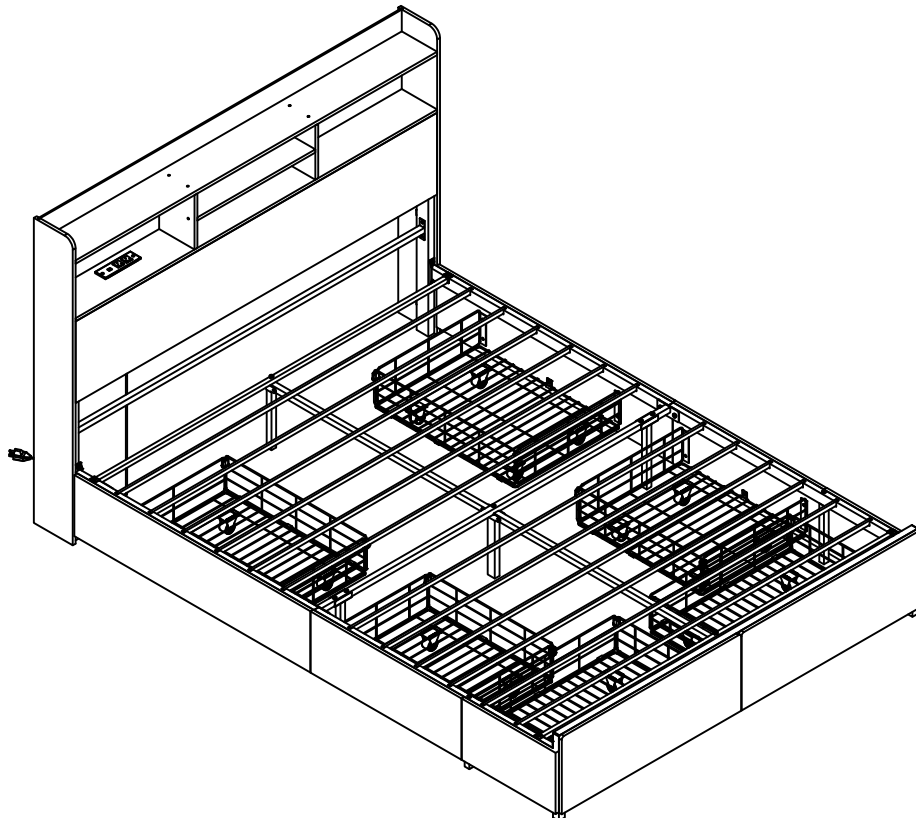

Before You Start

Read through each step carefully and follow the proper order

Separate and count all your parts and hardware





Give yourself enough room for the assembly process

Have the following tools: Flat Head Screwdriver, #2 Phillips Head Screwdriver and Hammer

Caution: If using a power drill or power screwdriver for screwing, please be aware of to slow down and stop when screw is tight. Failure to do so may result in stripping the screw. (Assembly speed can be increased by using electric screwdriver)

Parts Identification 1/2

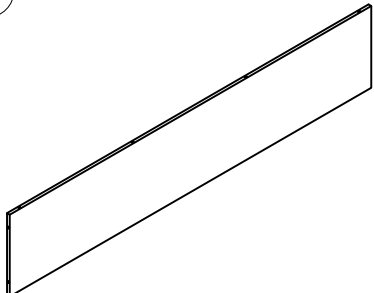
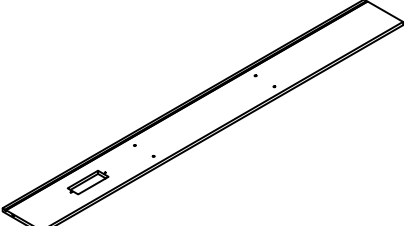
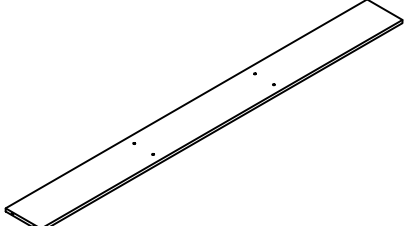
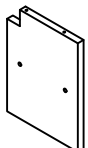
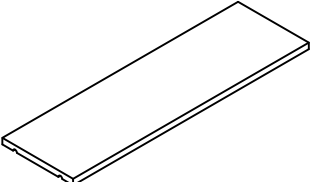
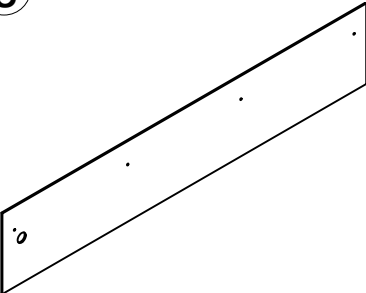
Not actual size

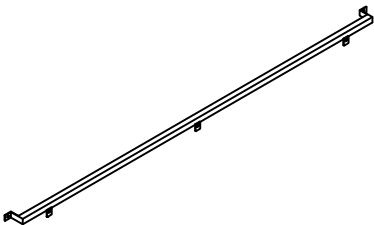
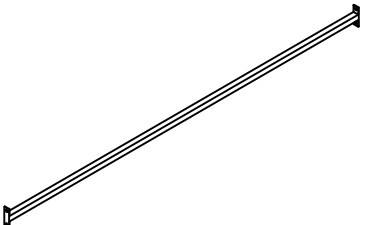
<p>①</p>  <p>Q'ty: 1</p>	<p>②</p>  <p>Q'ty: 1</p>	<p>③</p>  <p>Q'ty: 1</p>
<p>④</p>  <p>Q'ty: 1</p>	<p>⑤</p>  <p>Q'ty: 1</p>	<p>⑥</p>  <p>Q'ty: 2</p>
<p>⑦</p>  <p>Q'ty: 1</p>	<p>⑧</p>  <p>Q'ty: 1</p>	<p>⑨</p>  <p>Q'ty: 1</p>
<p>⑩</p>  <p>Q'ty: 1</p>	<p>⑪</p>  <p>Q'ty: 1</p>	<p>⑫</p>  <p>Q'ty: 1</p>

Parts Identification 2/2

Not actual size

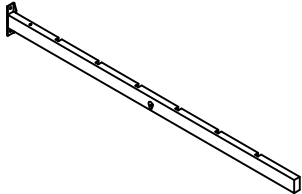
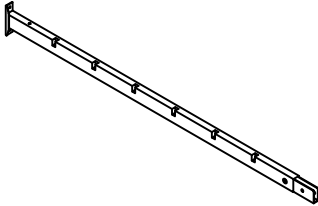
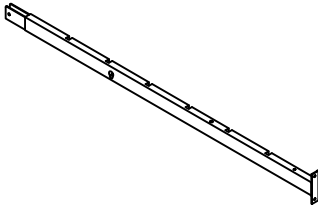
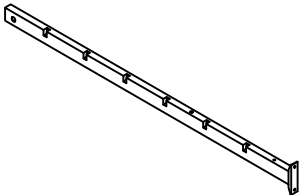
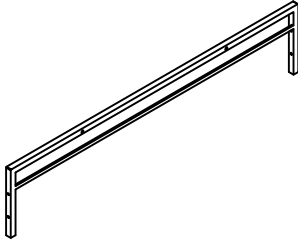
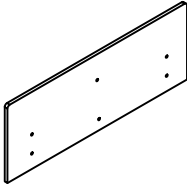
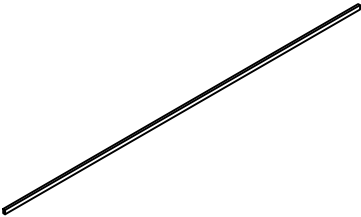
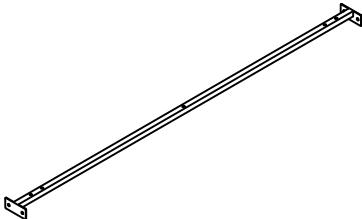
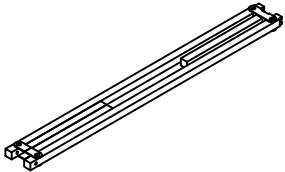
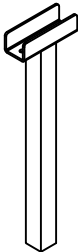
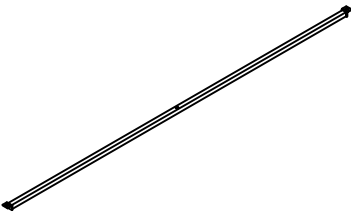
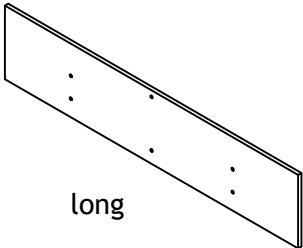
<p>13</p>  <p>Q'ty: 1</p>	<p>14</p>  <p>Q'ty: 1</p>	<p>15</p>  <p>Q'ty: 1</p>
<p>16</p>  <p>Q'ty: 1</p>	<p>17</p>  <p>Q'ty: 1</p>	<p>18</p>  <p>Q'ty: 2</p>
<p>19</p>  <p>Q'ty: 12</p>	<p>20</p>  <p>Q'ty: 1</p>	<p>21</p>  <p>Q'ty: 1</p>
<p>22</p>  <p>Q'ty: 2</p>	<p>23</p>  <p>Q'ty: 2</p>	<p>24</p>  <p>long</p> <p>Q'ty: 2</p>

Parts Identification 2/2

Not actual size

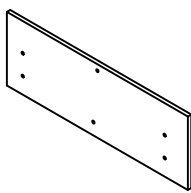
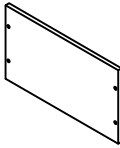
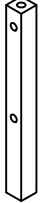
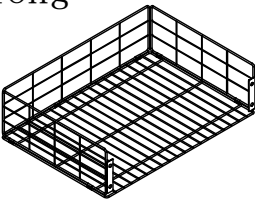
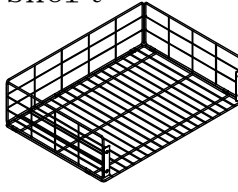





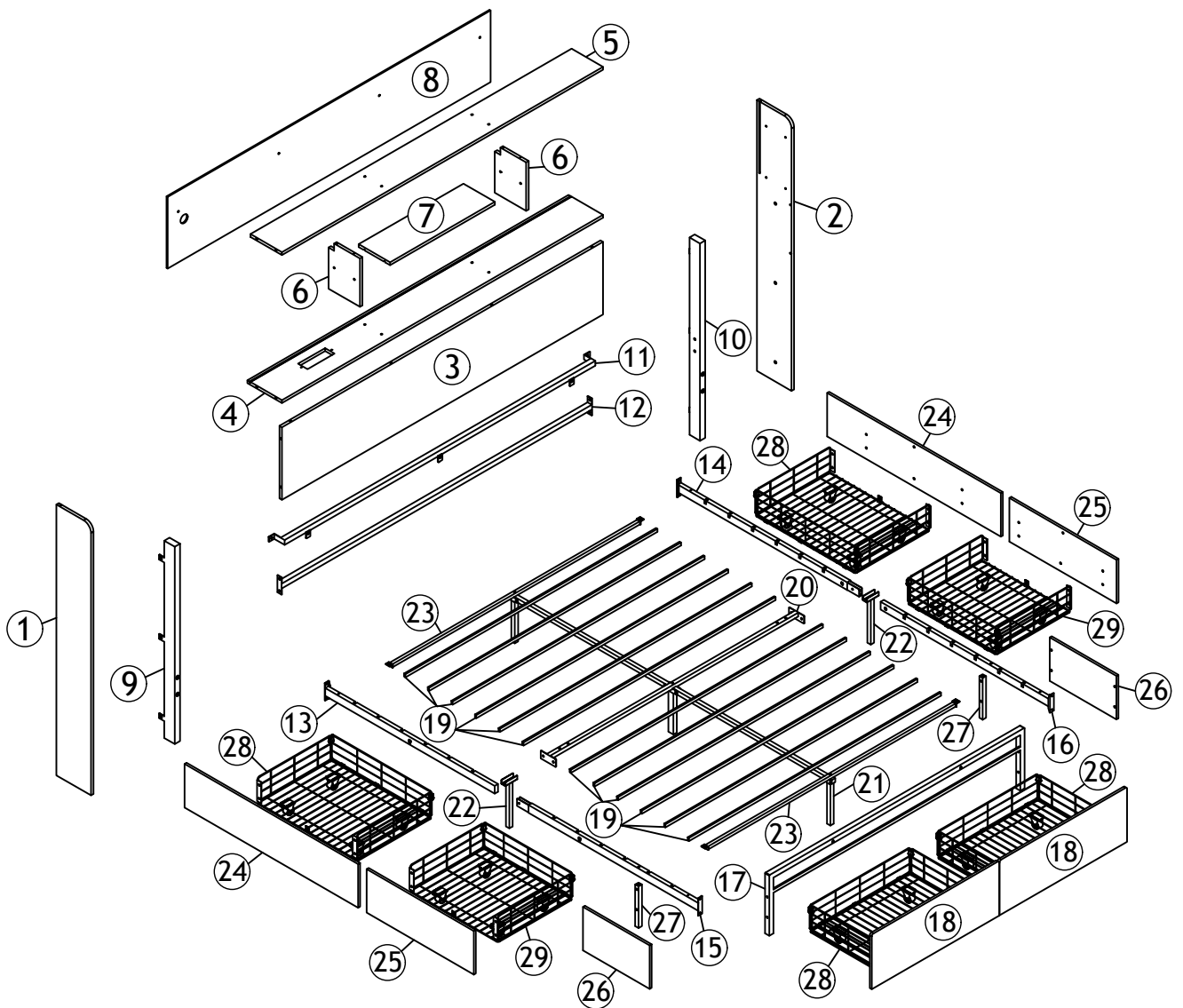

<p>(25)</p>  <p>Q'ty: 2</p>	<p>(26)</p>  <p>Q'ty: 2</p>	<p>(27)</p>  <p>Q'ty: 2</p>
<p>(28)</p> <p>long</p>  <p>Q'ty: 4</p>	<p>(29)</p> <p>short</p>  <p>Q'ty: 2</p>	

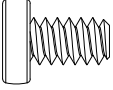
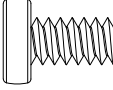
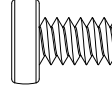
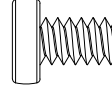
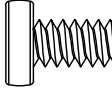
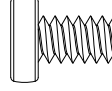
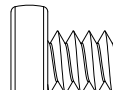
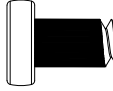
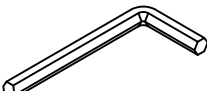
Parts Identification

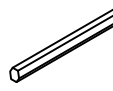
Not actual size

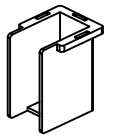
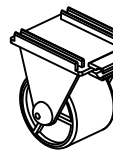

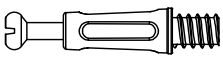
Hardware List

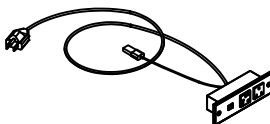
 Ø1/4" x 11mm (A) x 49 BOLT spare: 3	 Ø1/4" x 16mm (B) x 8 BOLT spare: 1	 Ø1/4" x 25mm (C) x 4 BOLT spare: 1	 Ø1/4" x 28mm (D) x 4 BOLT spare: 1
 Ø1/4" x 32mm (E) x 4 BOLT spare: 1	 Ø1/4" x 65mm (F) x 5 BOLT spare: 1	 M8 x 13mm (G) x 4 BOLT spare: 1	 Ø1/4" x 16mm (H) x 6 BOLT spare: 1
 M4 (I) x 1 ALLEN KEY	 M5 (J) x 1 ALLEN KEY	 M3 (K) x 1 ALLEN KEY	 Ø5 x 38mm (L) x 12 spare: 1
 (M) x 1 CABLE HOLE COVER	 (N) x 24 PLASTIC CAP	 (O) x 24 CASTER	 (P) x 12 DRAWER CLIP
 (Q) x 6 DRAWER CLIP	 (R) x 16 spare: 1	 (S) x 16 spare: 1	 (T) x 1 SOCKET

Hardware List

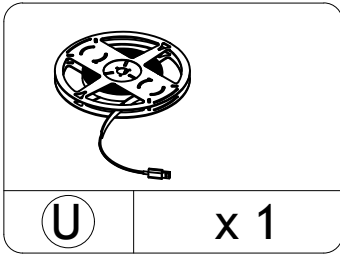

LED STRIP

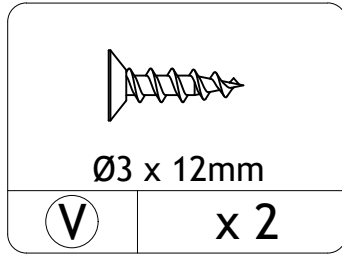

SOCKET

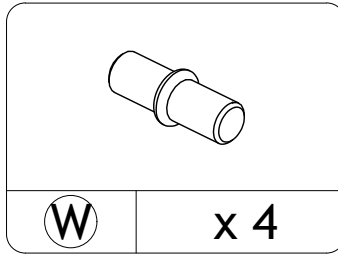

STEP 1

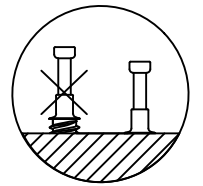
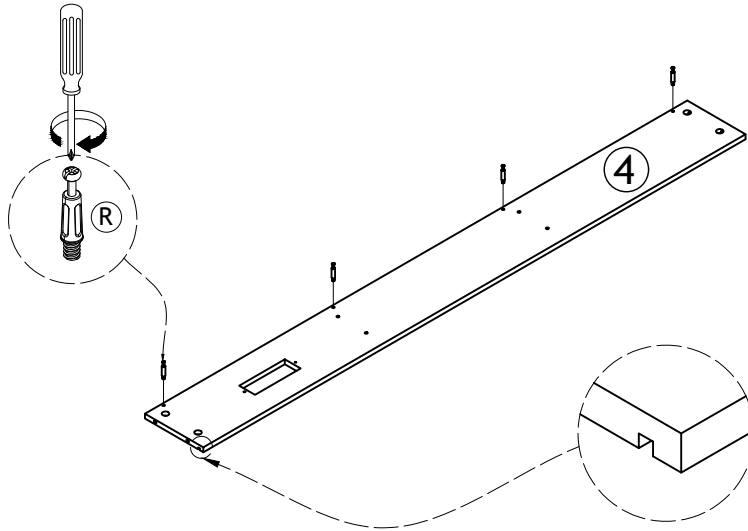
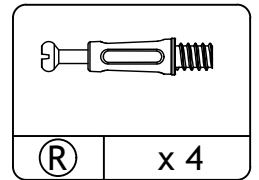
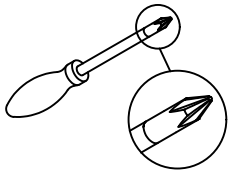

STEP 2

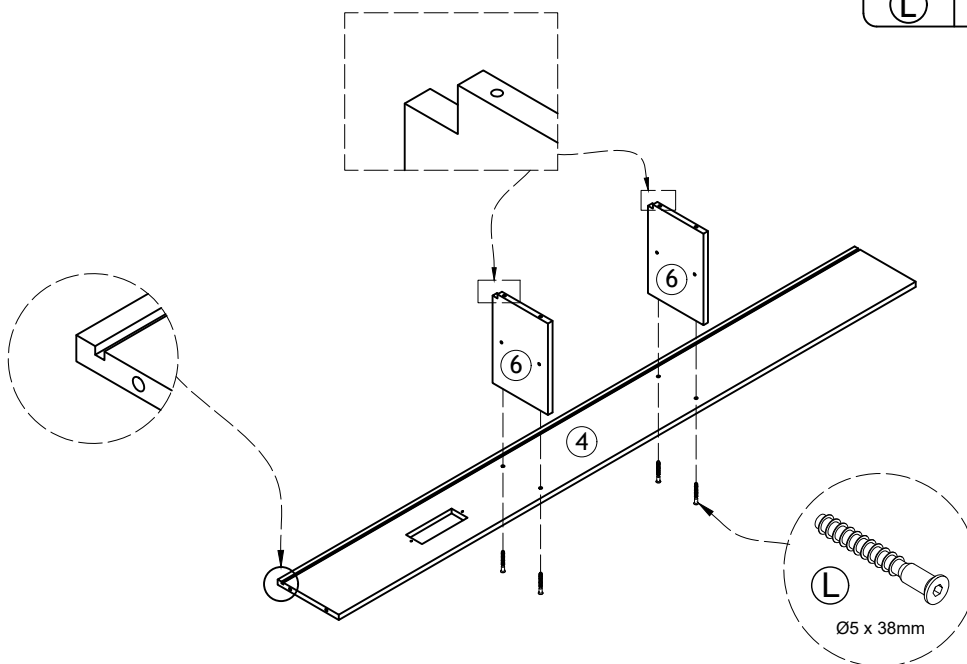
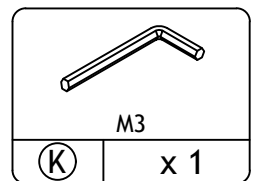
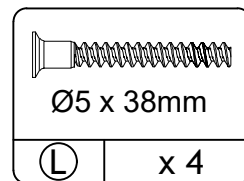

STEP 3

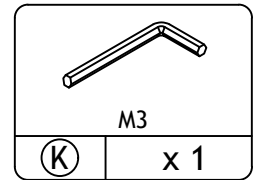
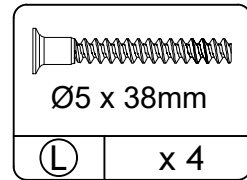
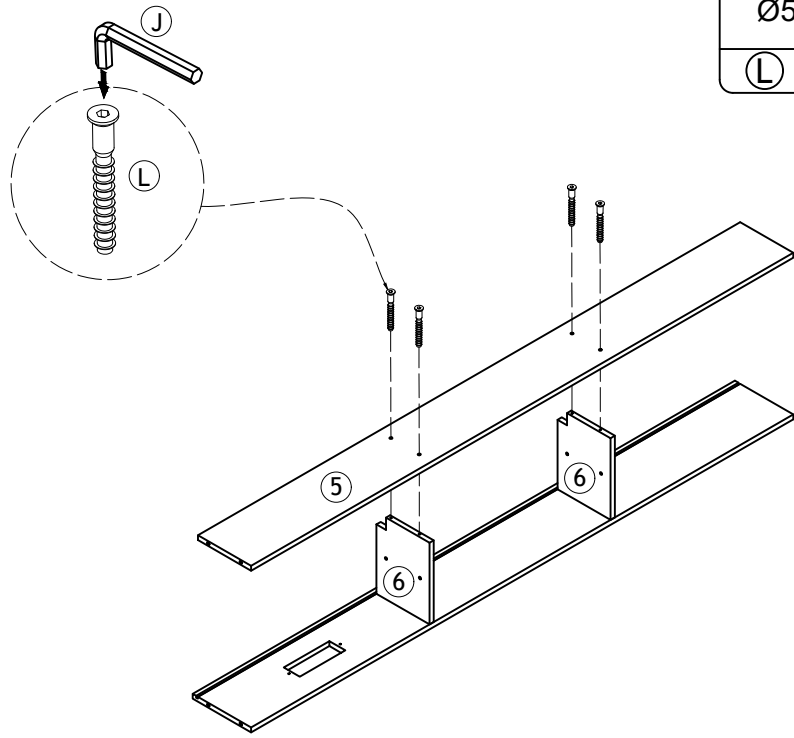

STEP 4

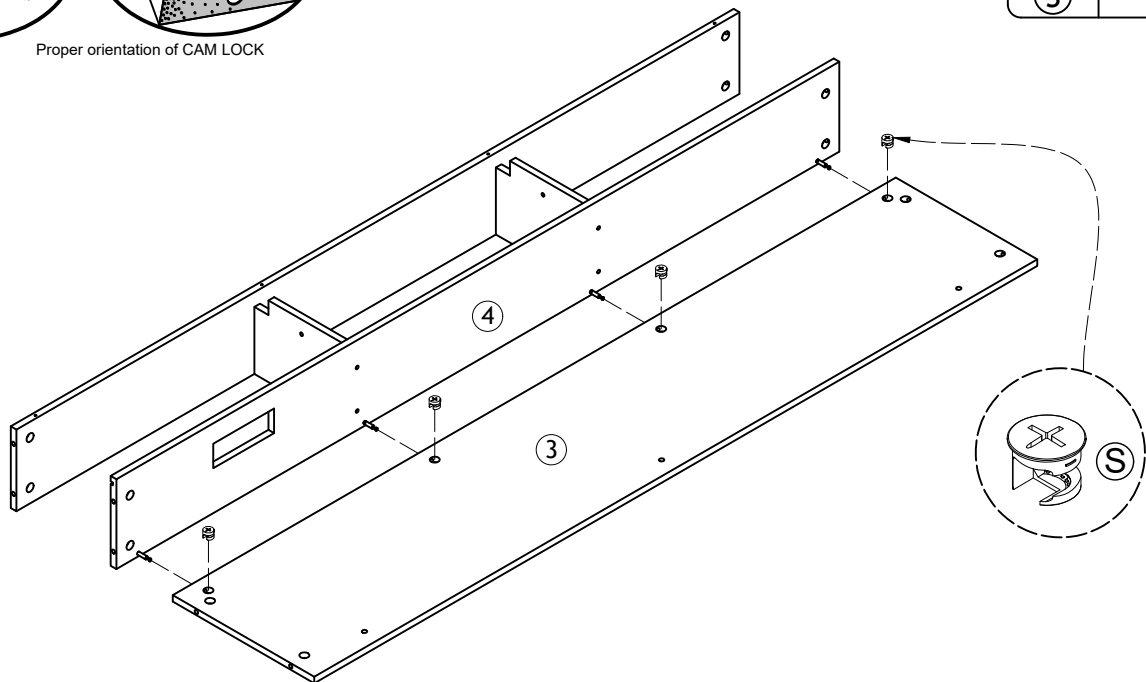
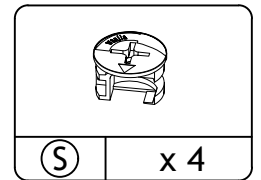
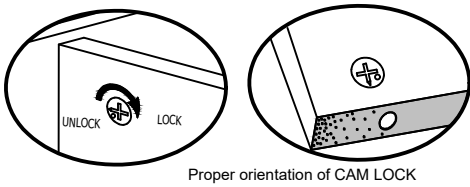

STEP 5

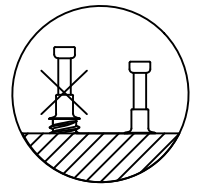
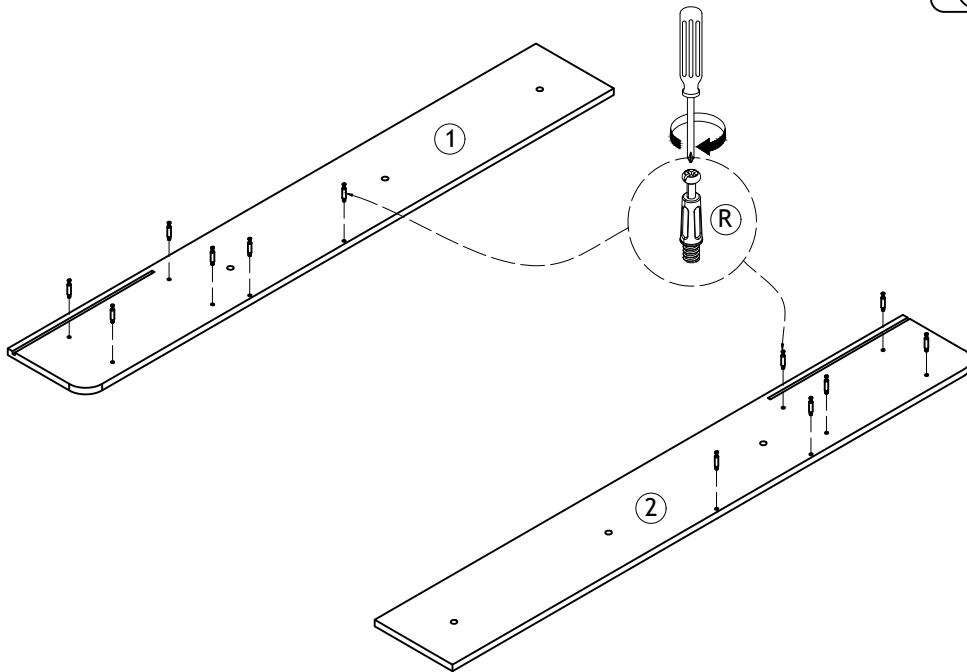
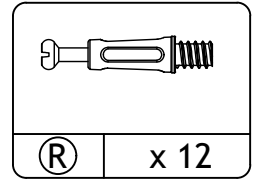
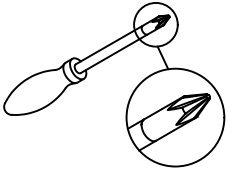

STEP 6

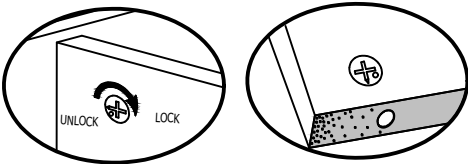

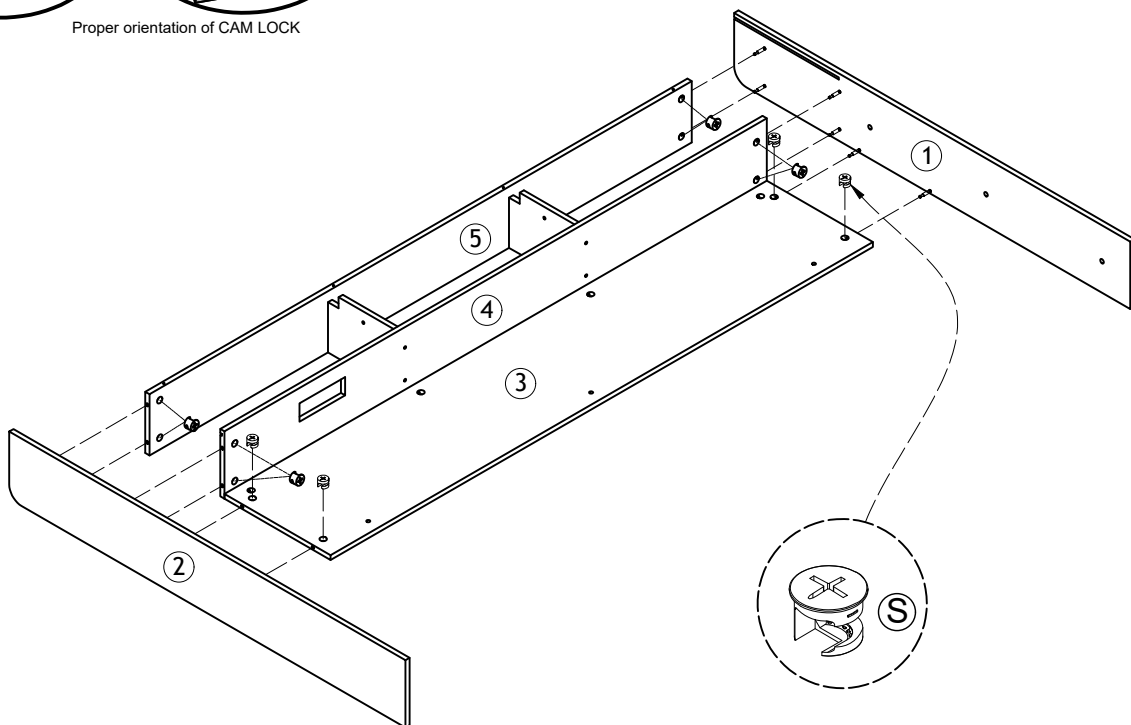
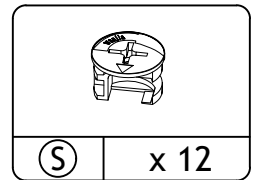

Proper orientation of CAM LOCK



STEP 7

 Please tighten the bolts to 80% first, and tighten all bolts 100% after all parts are assembled.

	
---	---

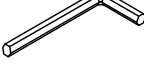

Ø1/4" x 11mm
(A) x 6

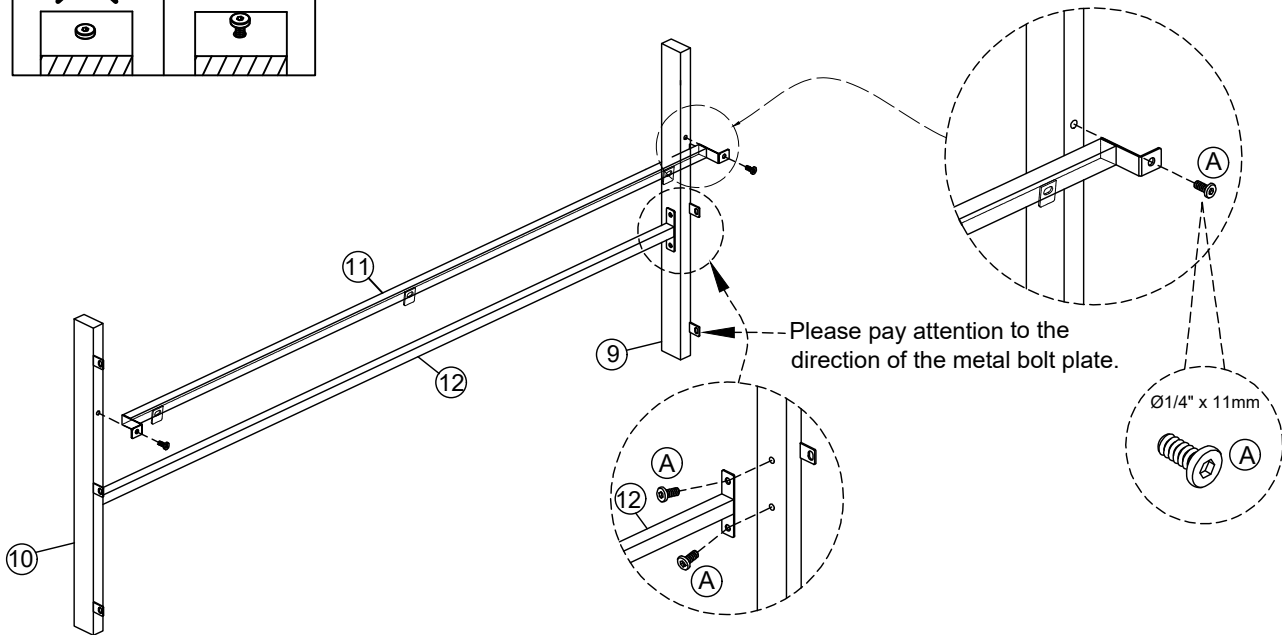

M4
(I) x 1



STEP 8

 Please tighten the bolts to 80% first, and tighten all bolts 100% after all parts are assembled.

	
---	---

Ø1/4" x 11mm
(A) x 9

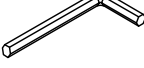

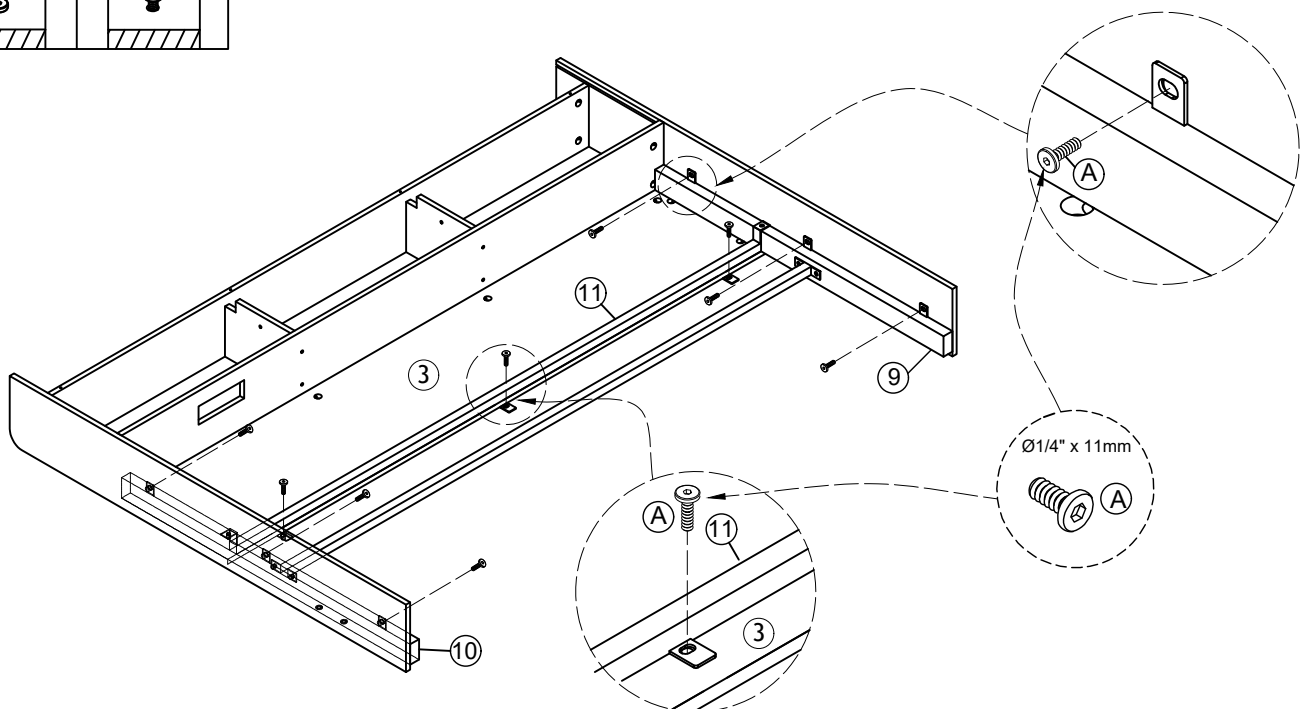
M4
(I) x 1

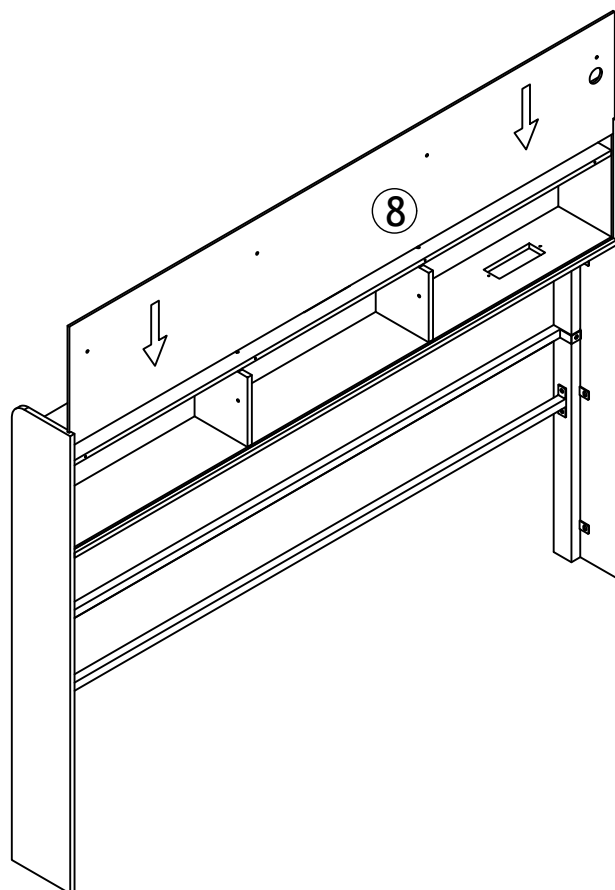

STEP 9

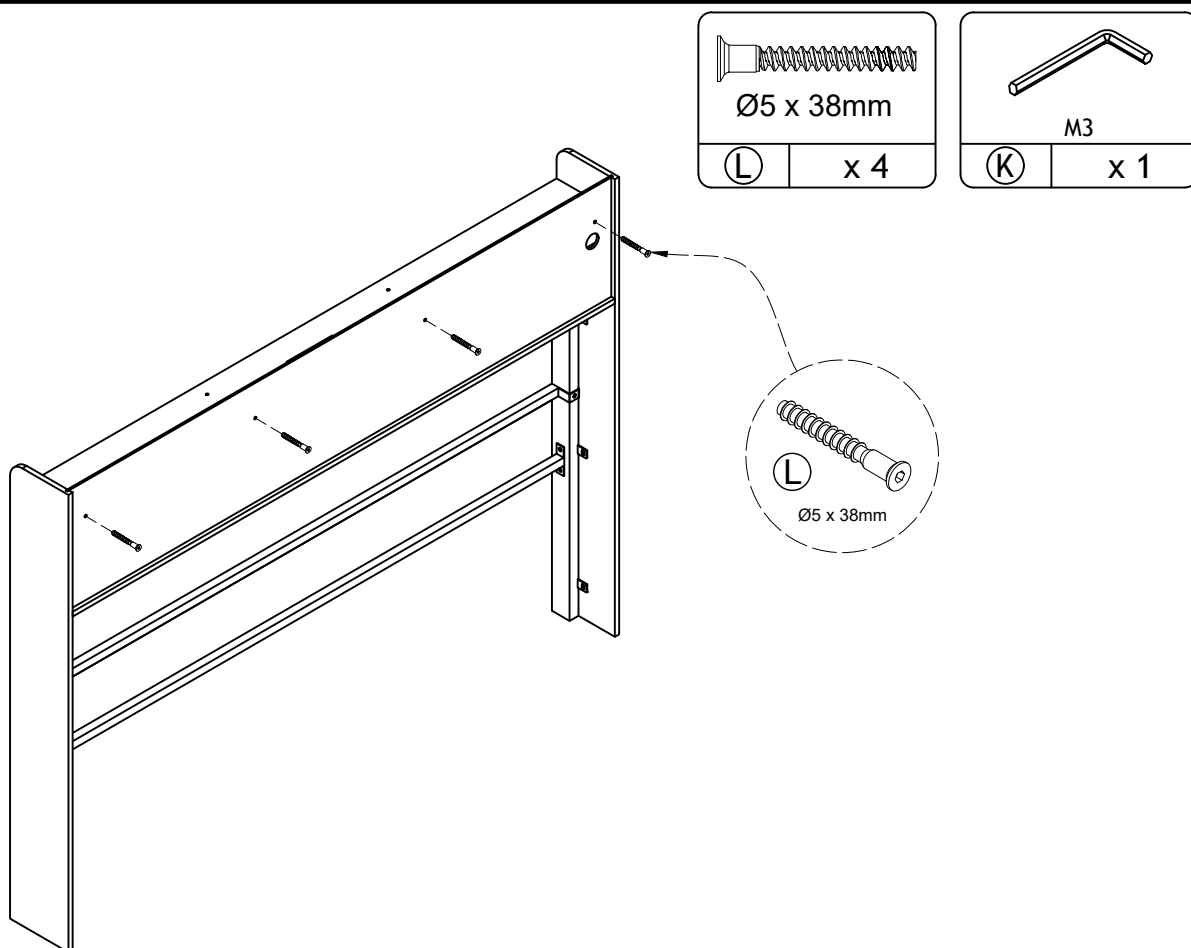

STEP 10



STEP 11

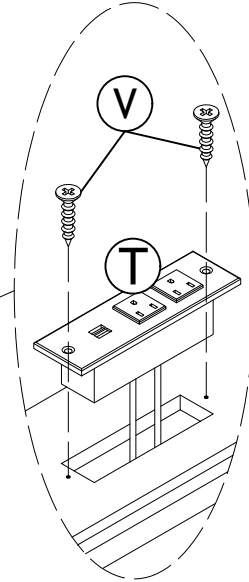
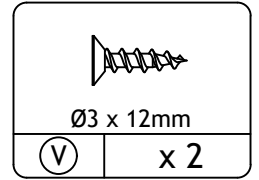
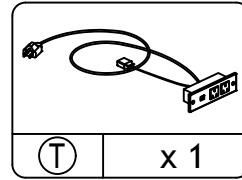
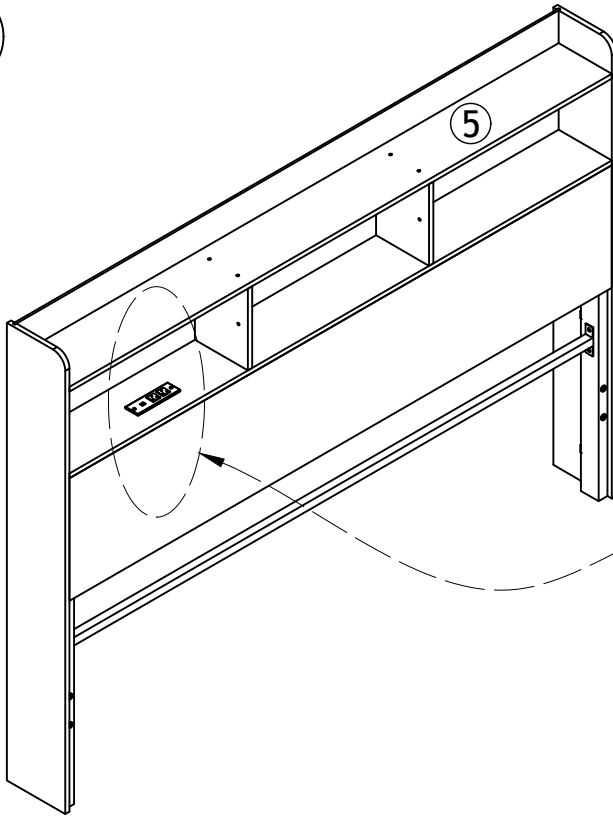
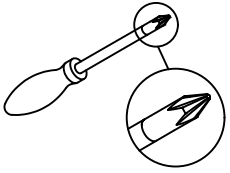

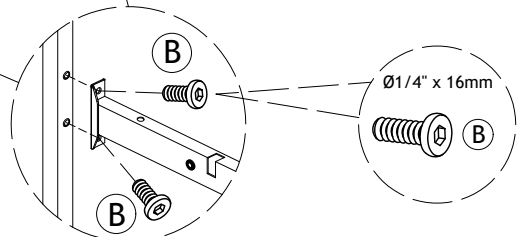
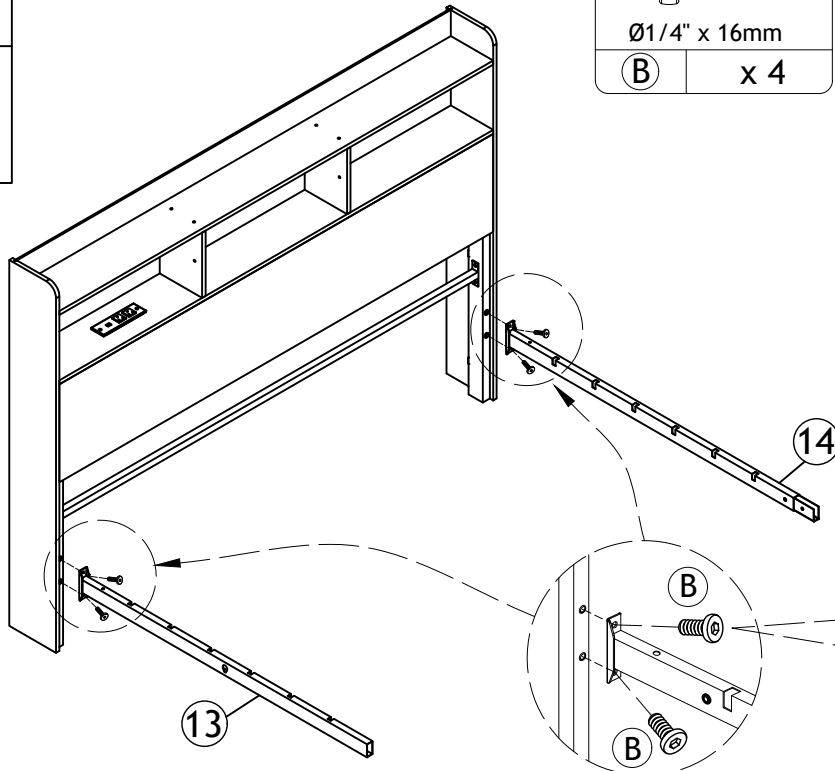
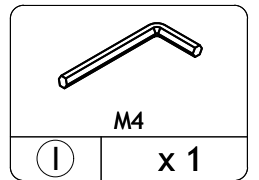
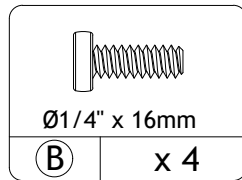

STEP 12

Please tighten the bolts to 80% first, and tighten all bolts 100% after all parts are assembled.





STEP 13

 Please tighten the bolts to 80% first, and tighten all bolts 100% after all parts are assembled.

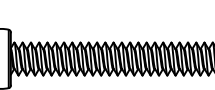
	
---	---

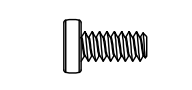

Ø1/4" x 65mm
(F) x 2

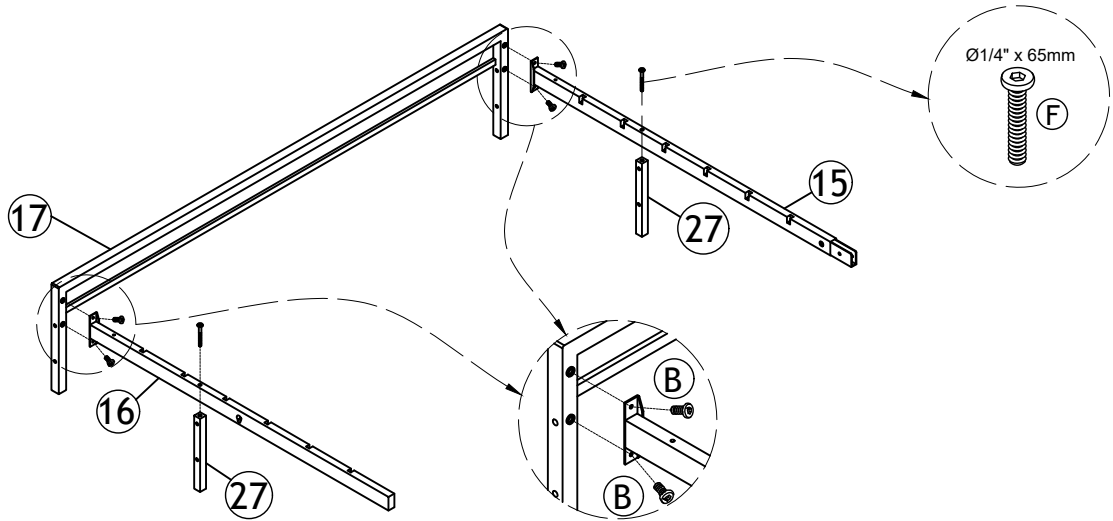

Ø1/4" x 16mm
(B) x 4

M4
(I) x 1

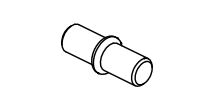

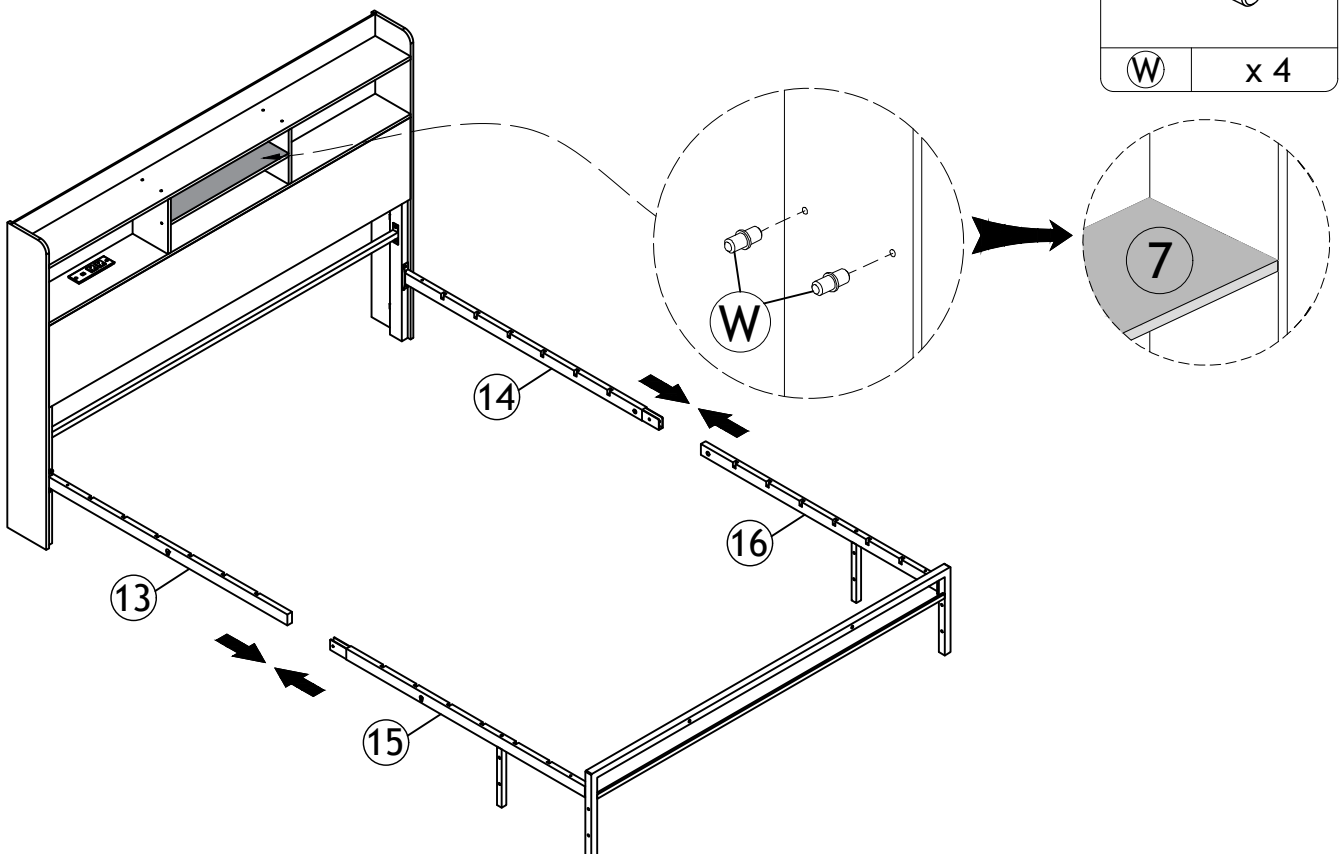

STEP 14



(W) x 4



STEP 15

 Please tighten the bolts to 80% first, and tighten all bolts 100% after all parts are assembled.

	
---	---

Ø1/4" x 11mm
(A) x 4

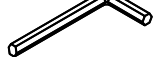
M4
(I) x 1

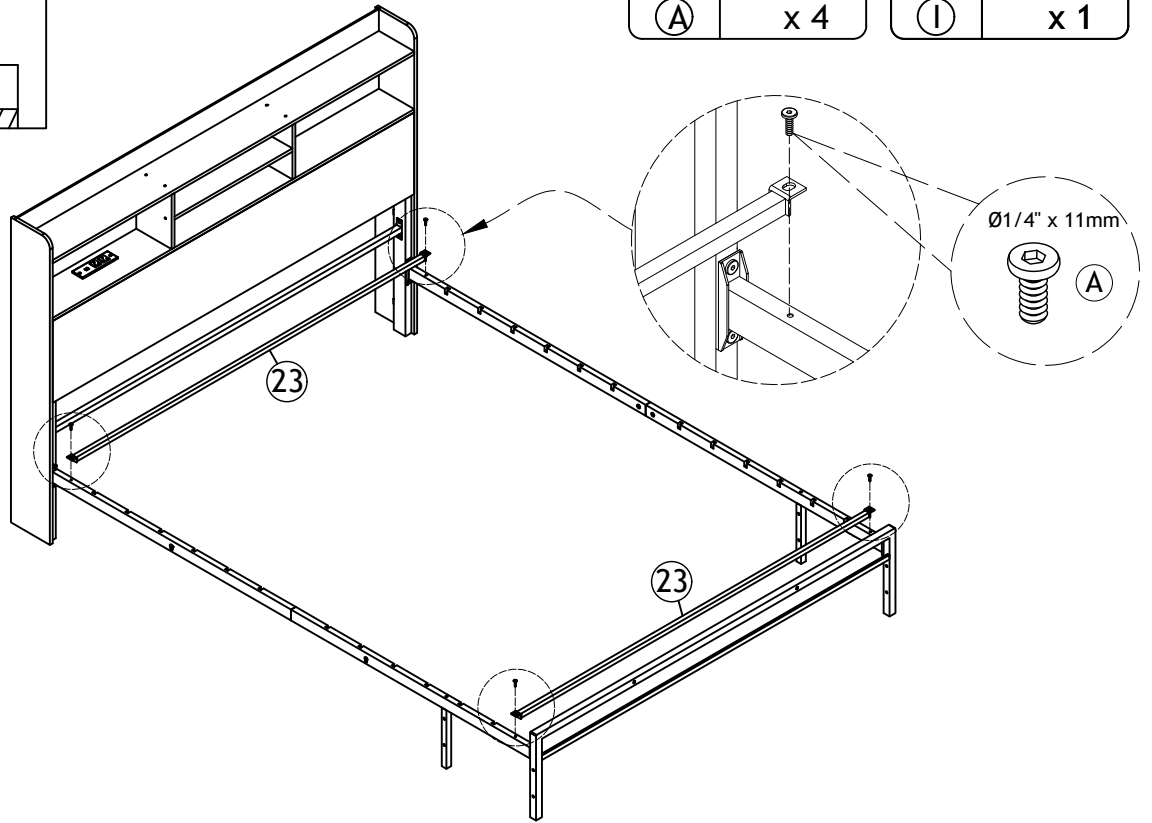

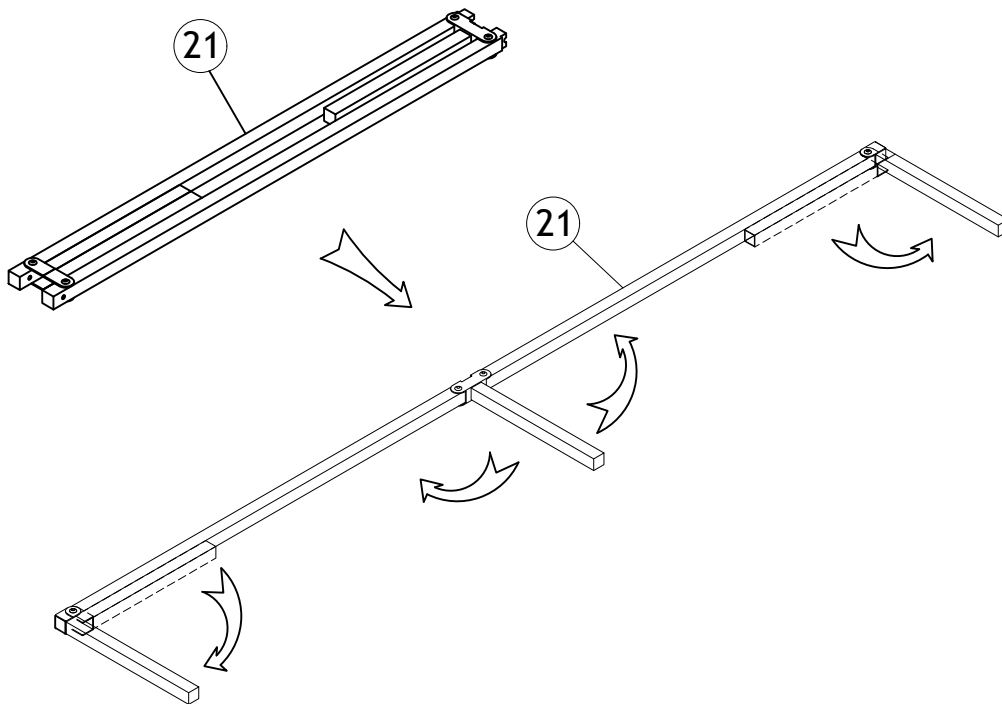

STEP 16



Expand the folded portion

STEP 17

 Please tighten the bolts to 80% first, and tighten all bolts 100% after all parts are assembled.

	
---	---

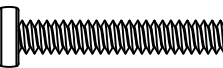

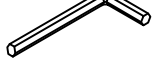
Ø1/4" x 65mm
(F) x 2

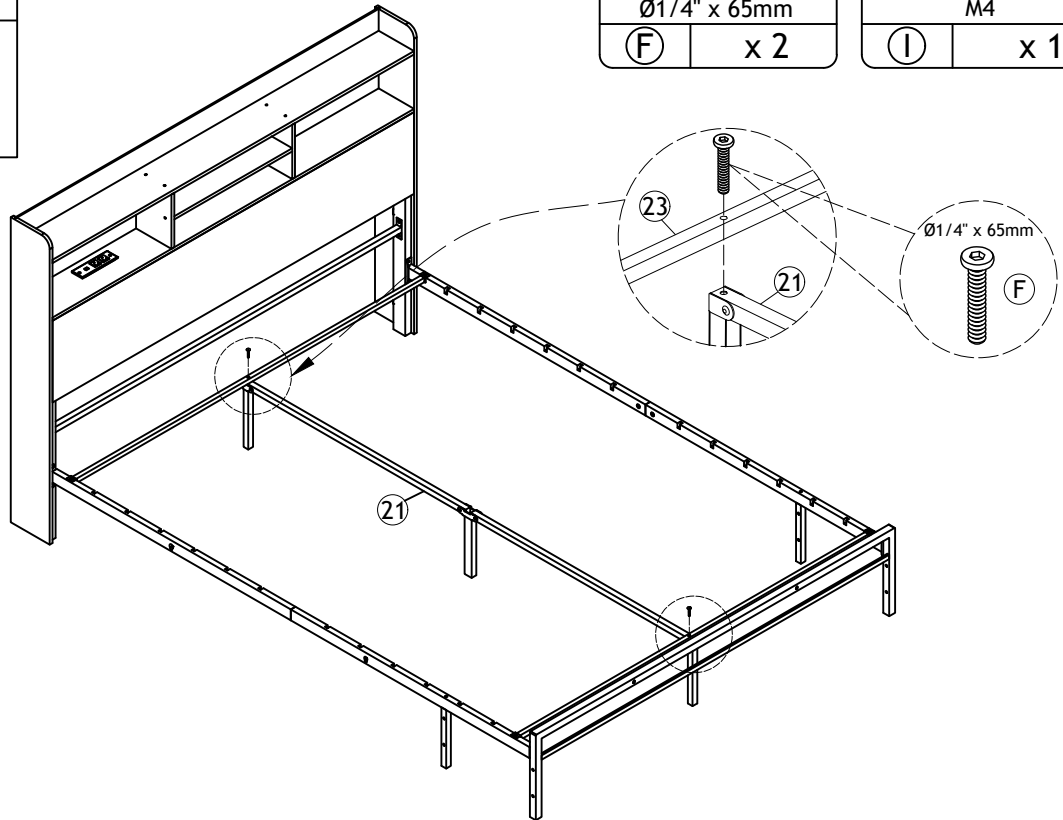

M4
(I) x 1



STEP 18

 Please tighten the bolts to 80% first, and tighten all bolts 100% after all parts are assembled.

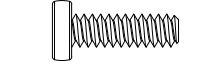
	
---	---

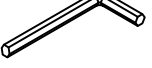

Ø1/4" x 25mm
(C) x 4

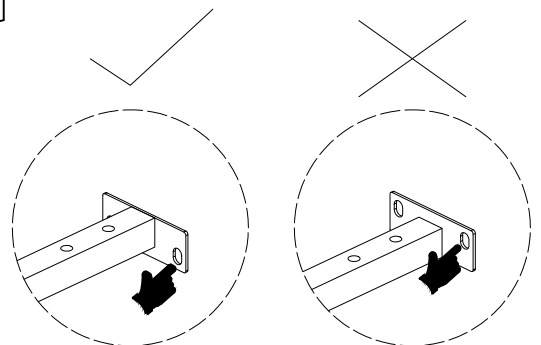
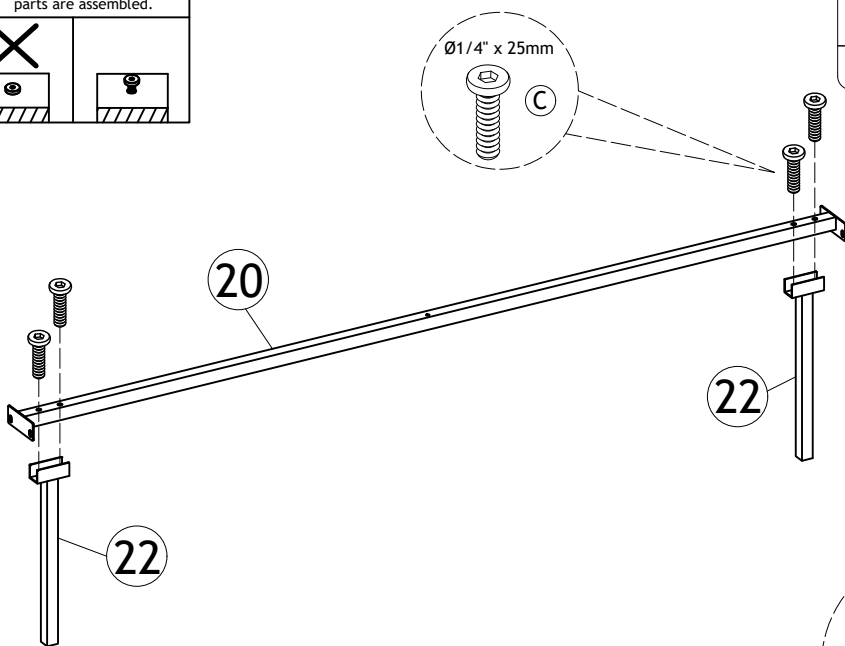

M4
(I) x 1



ATTENTION: This metal plate is on the bottom instead of on top. Don't install it wrongly.

STEP 19

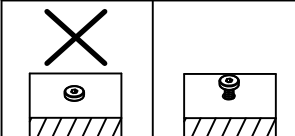
 Please tighten the bolts to 80% first, and tighten all bolts 100% after all parts are assembled.

M8 x 13mm
G x 4



Ø1/4" x 65mm
F x 1



M4
I x 1



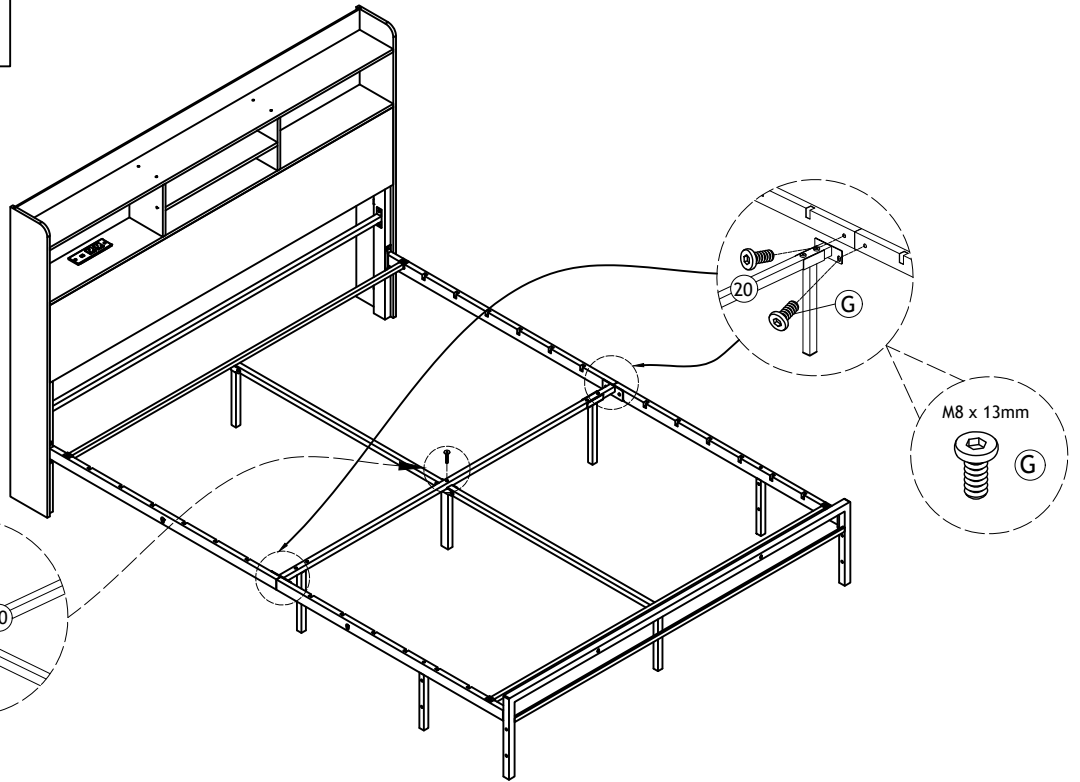

M5
J x 1

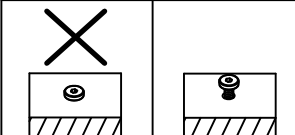

STEP 20

 Please tighten the bolts to 80% first, and tighten all bolts 100% after all parts are assembled.

Ø1/4" x 28mm
D x 4



Ø1/4" x 32mm
E x 4



M4
I x 1

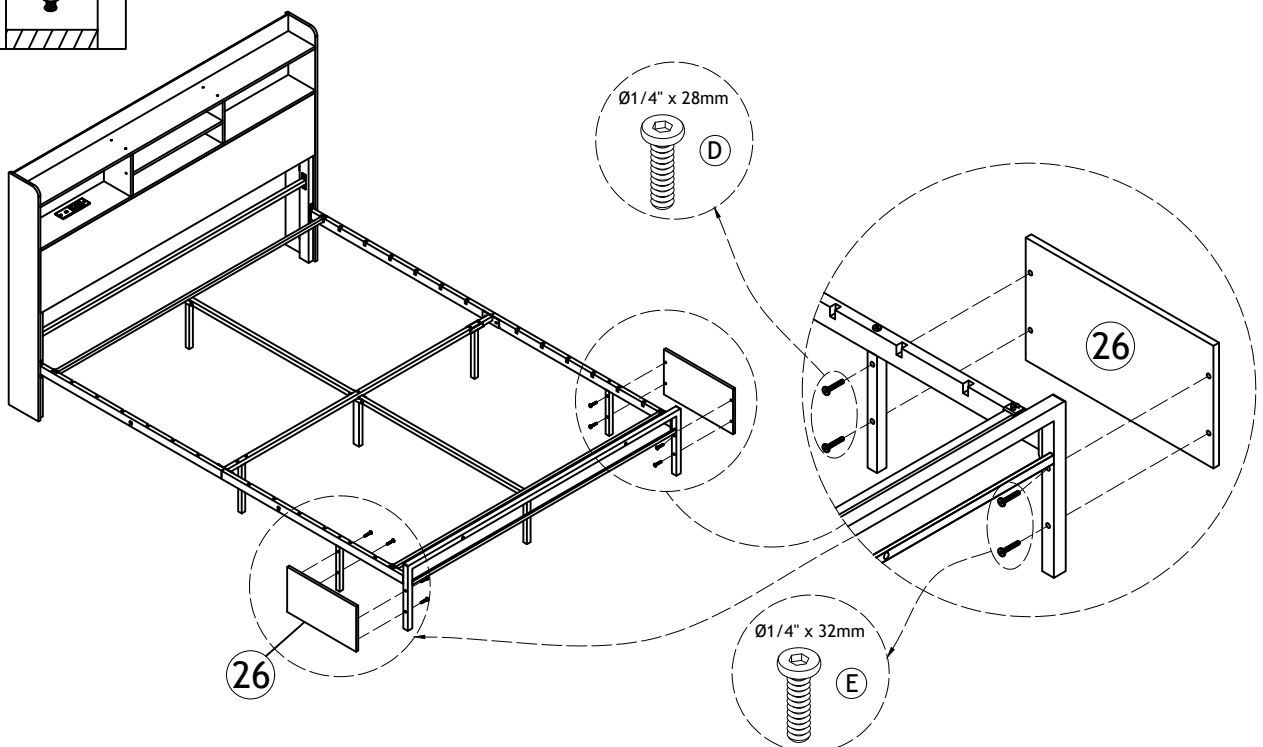

STEP 21

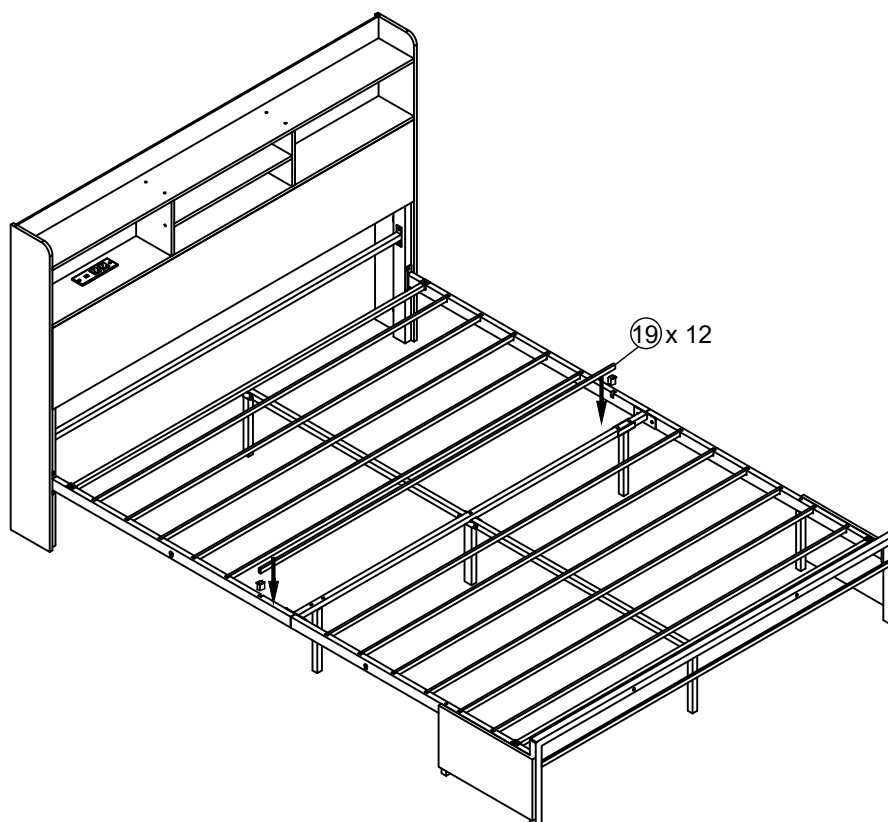
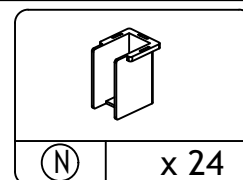

Assemble the slats

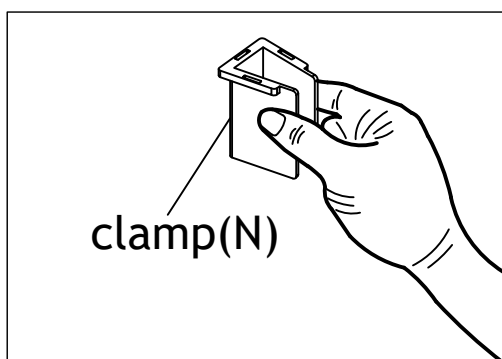

1. Squeeze the clamp (N) tightly.

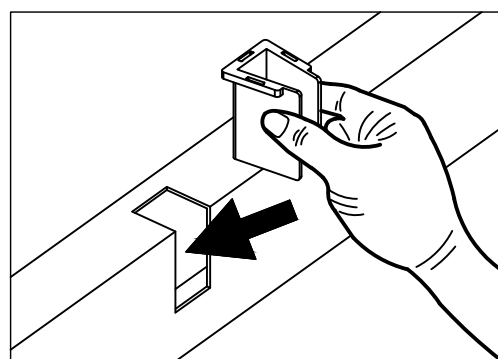

2. Put the clamp into the gaps.

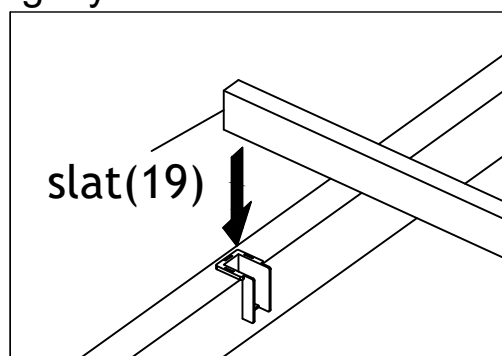

3. Put the slat (19) into the clamp.

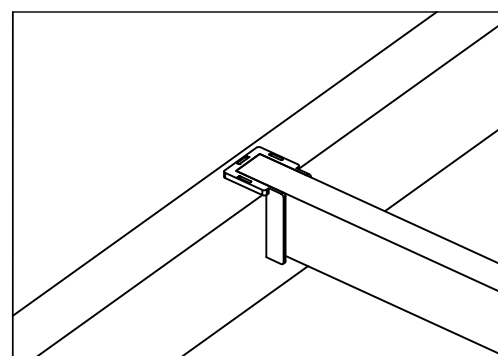

4. Finished.

STEP 22

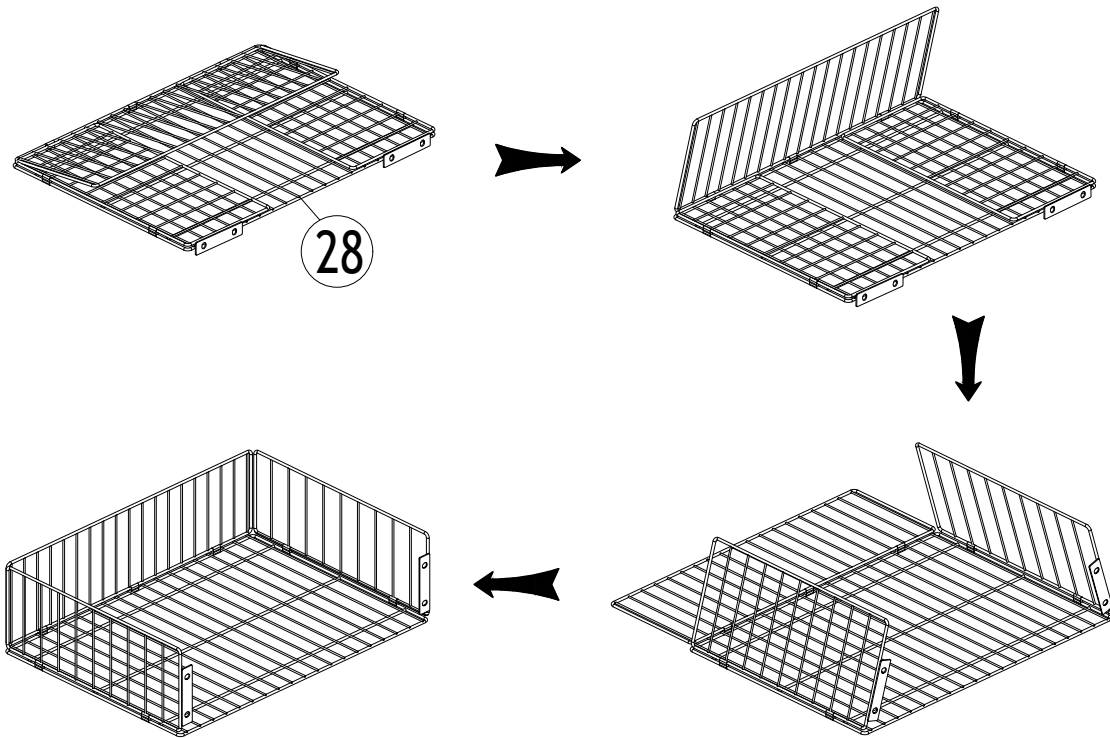

STEP 23

X4

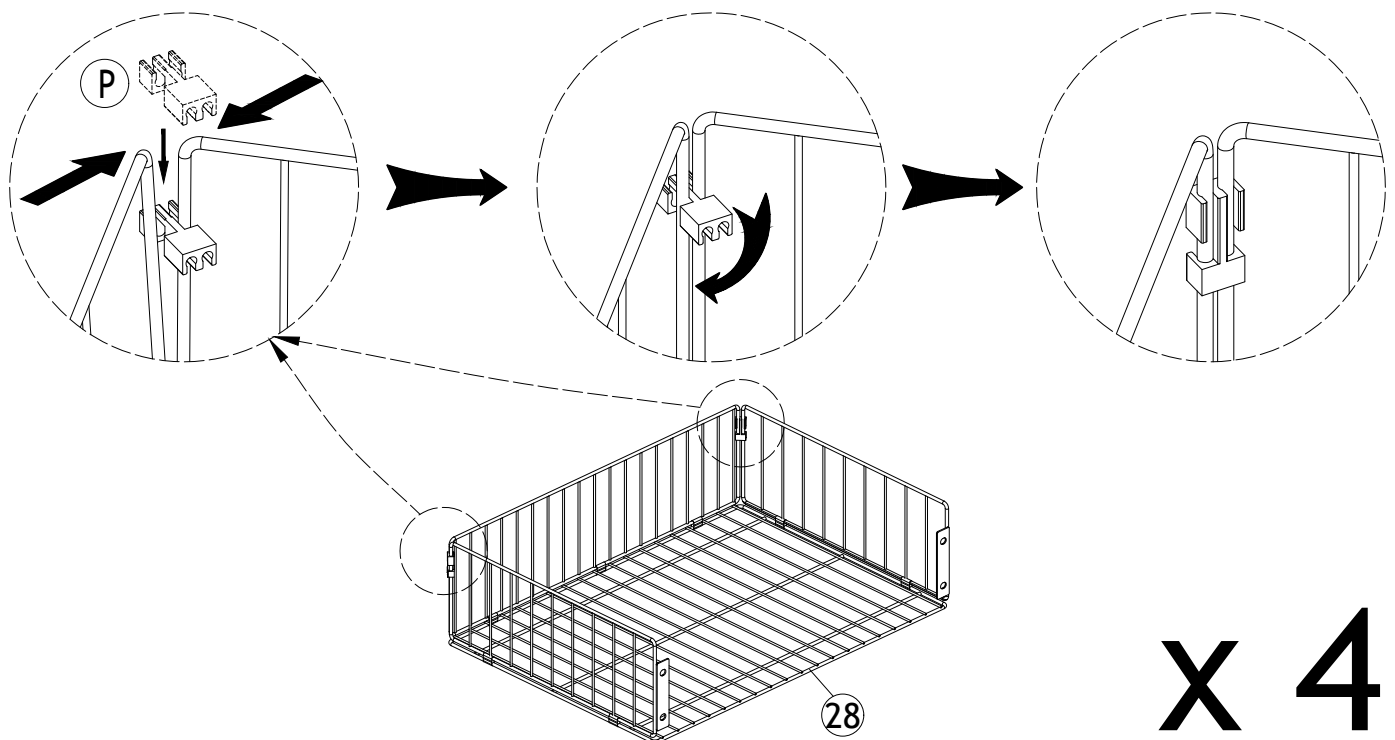
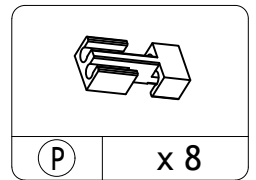

X 4

STEP 24

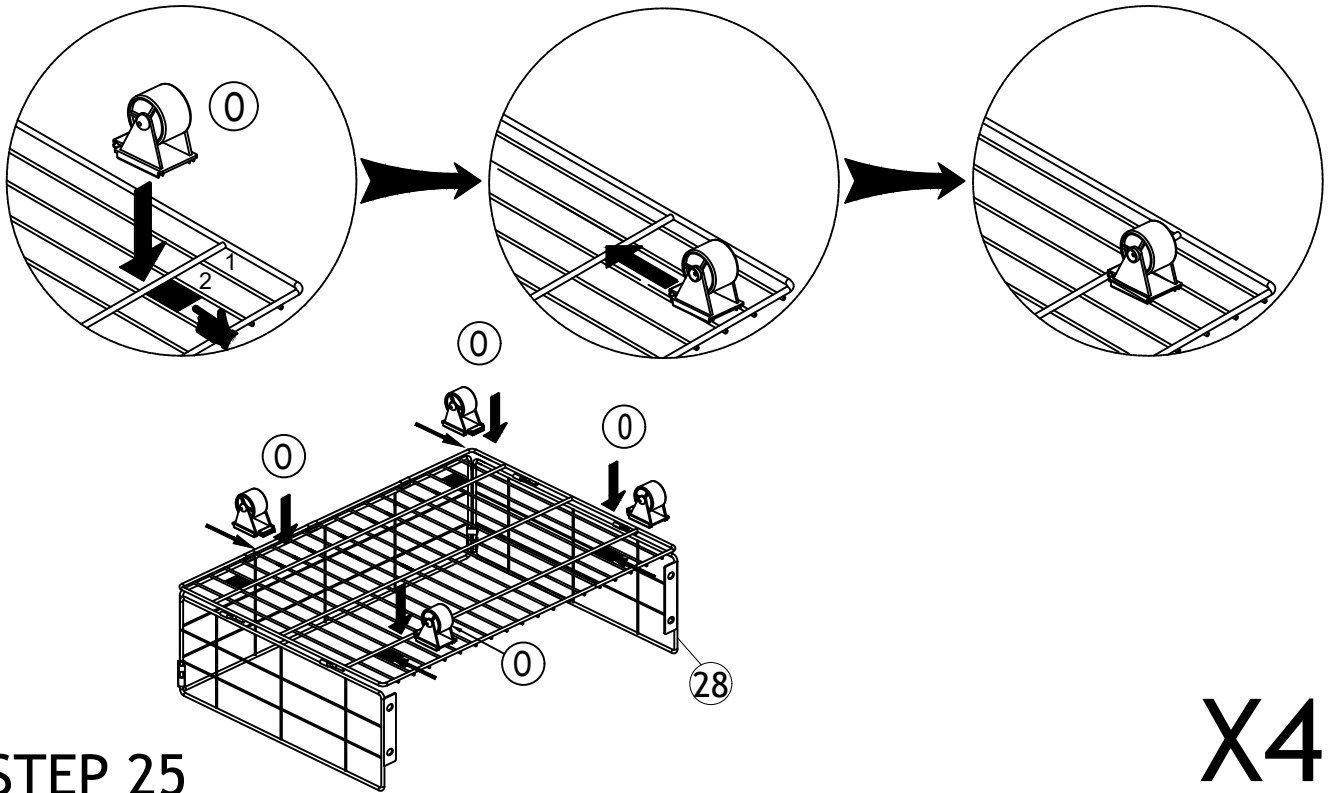
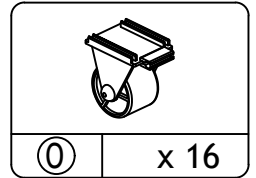

STEP 25

X4

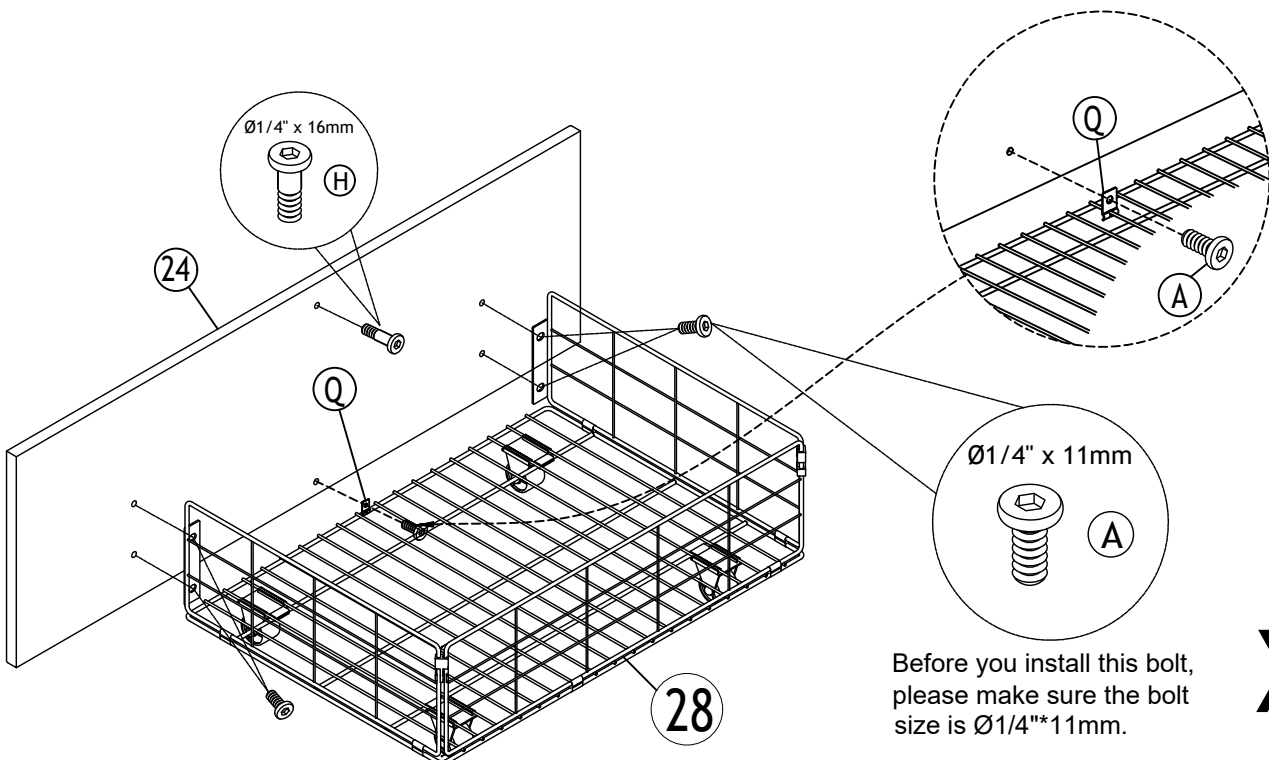
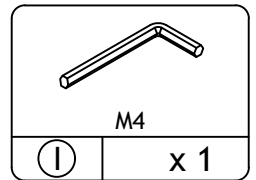
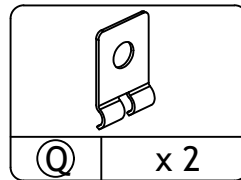
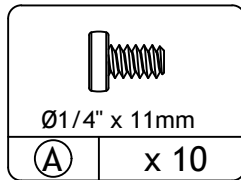
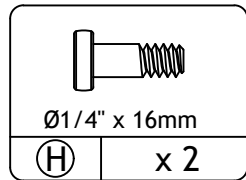

Before you install this bolt, please make sure the bolt size is Ø1/4" x 11mm.

X2

STEP 26

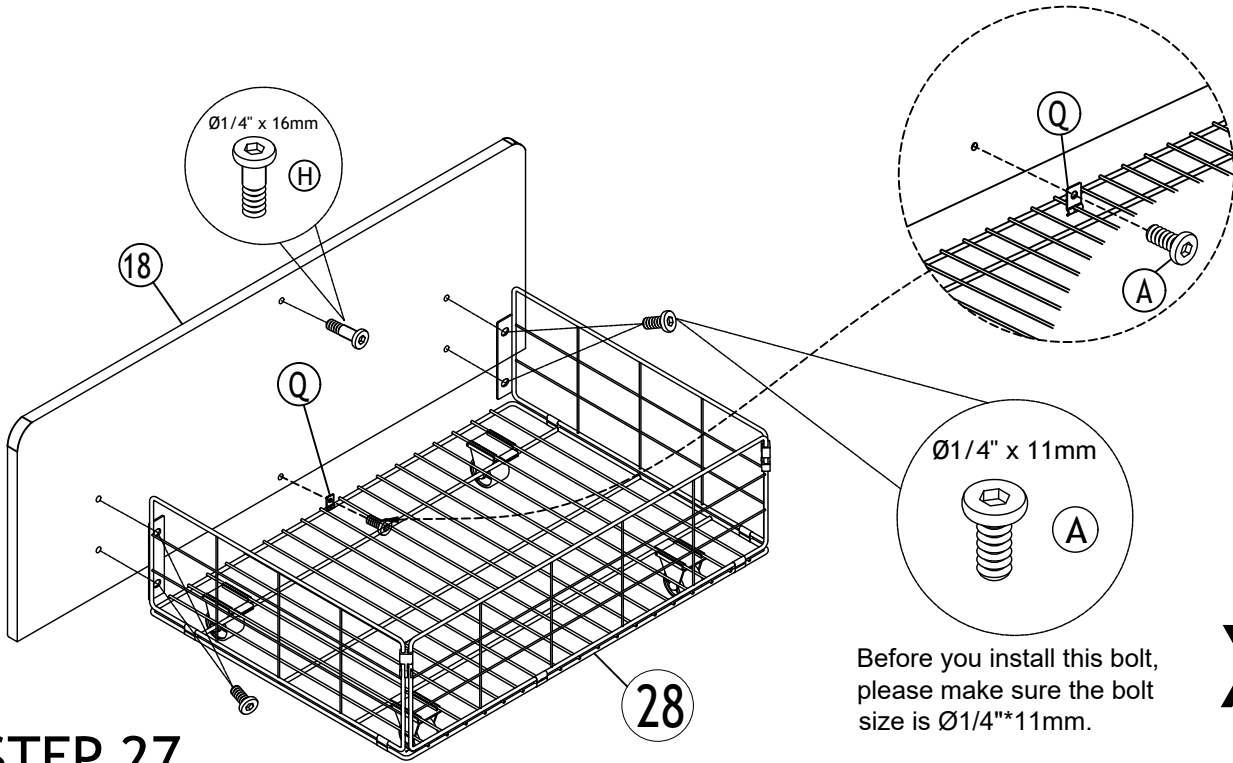
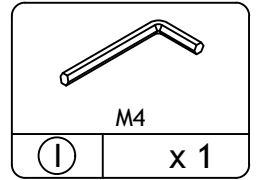
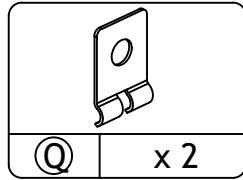
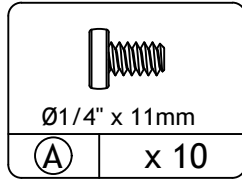
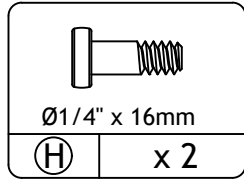

STEP 27

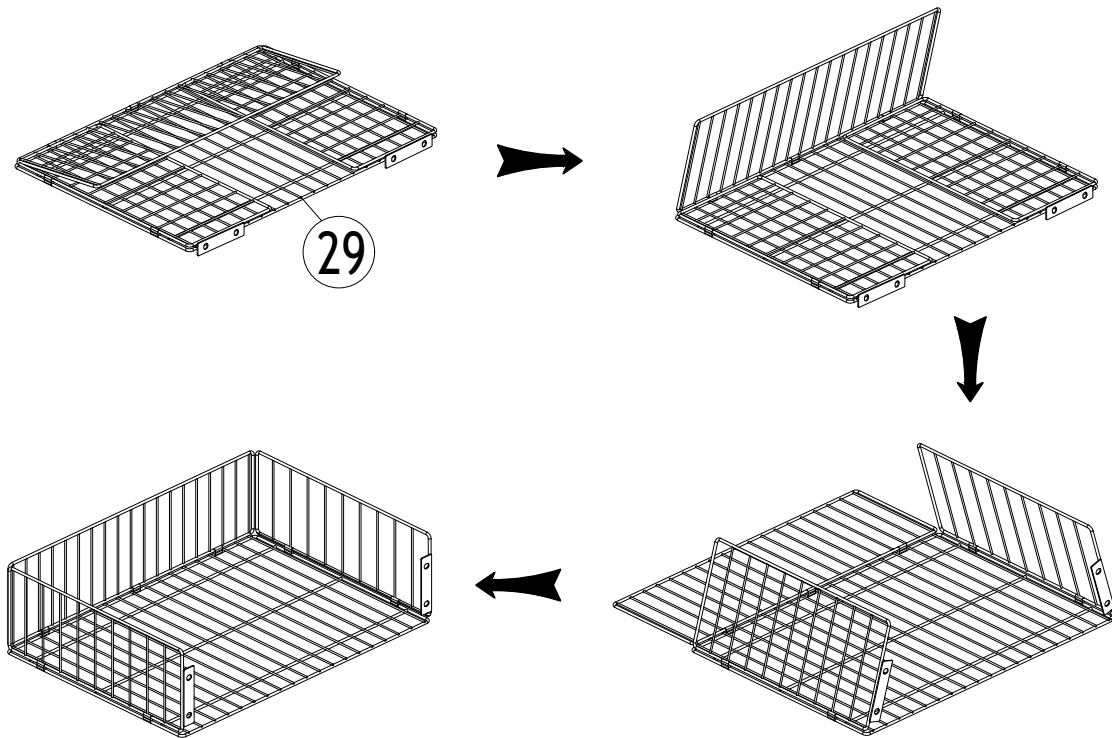

STEP 28

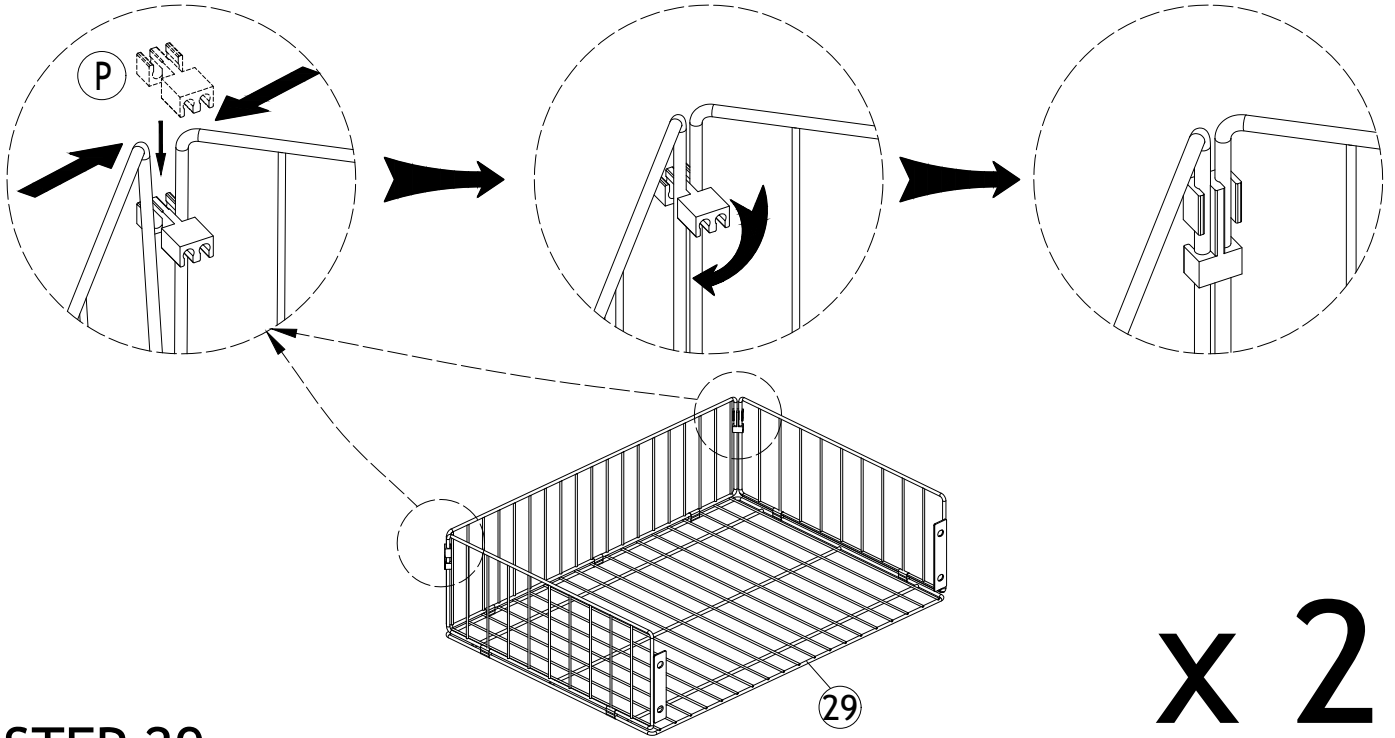
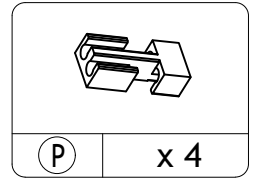

STEP 29

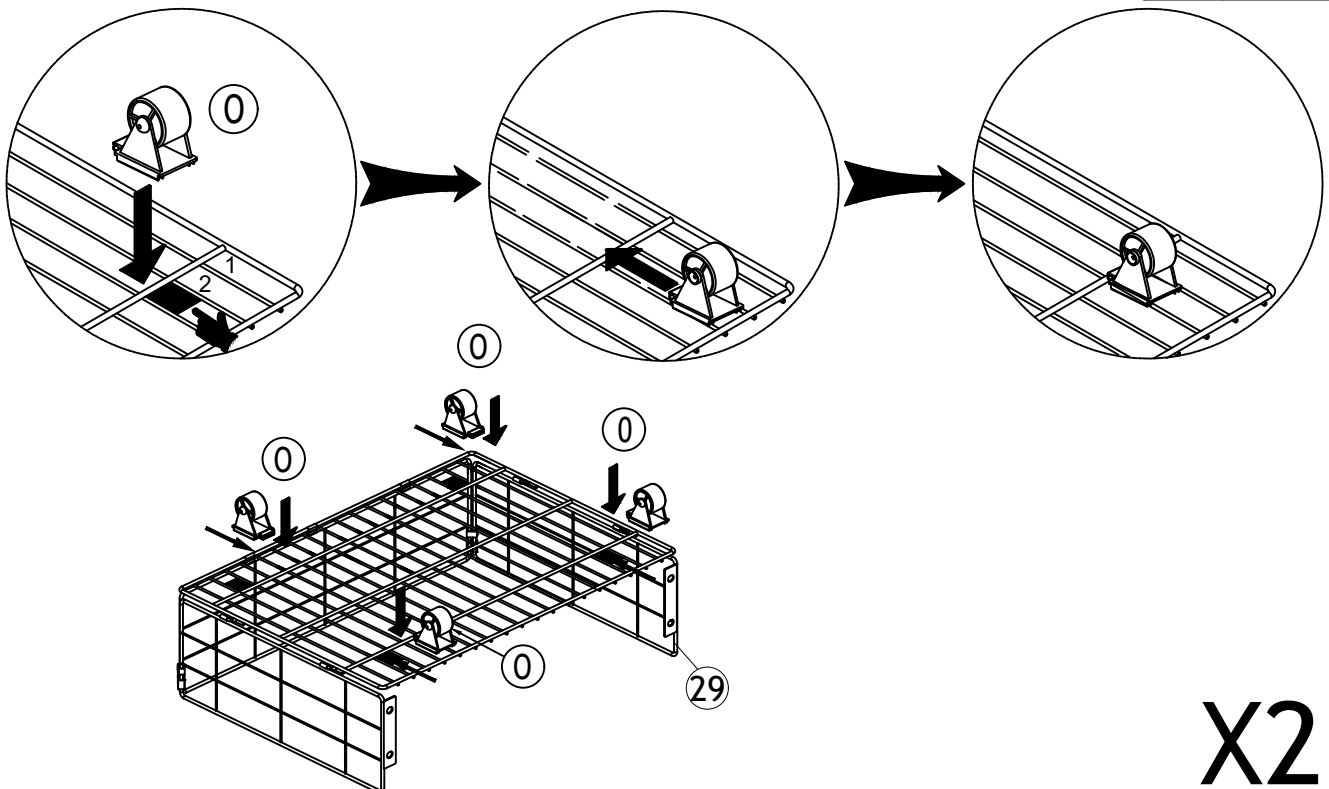
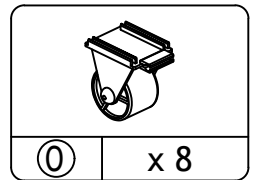

STEP 30

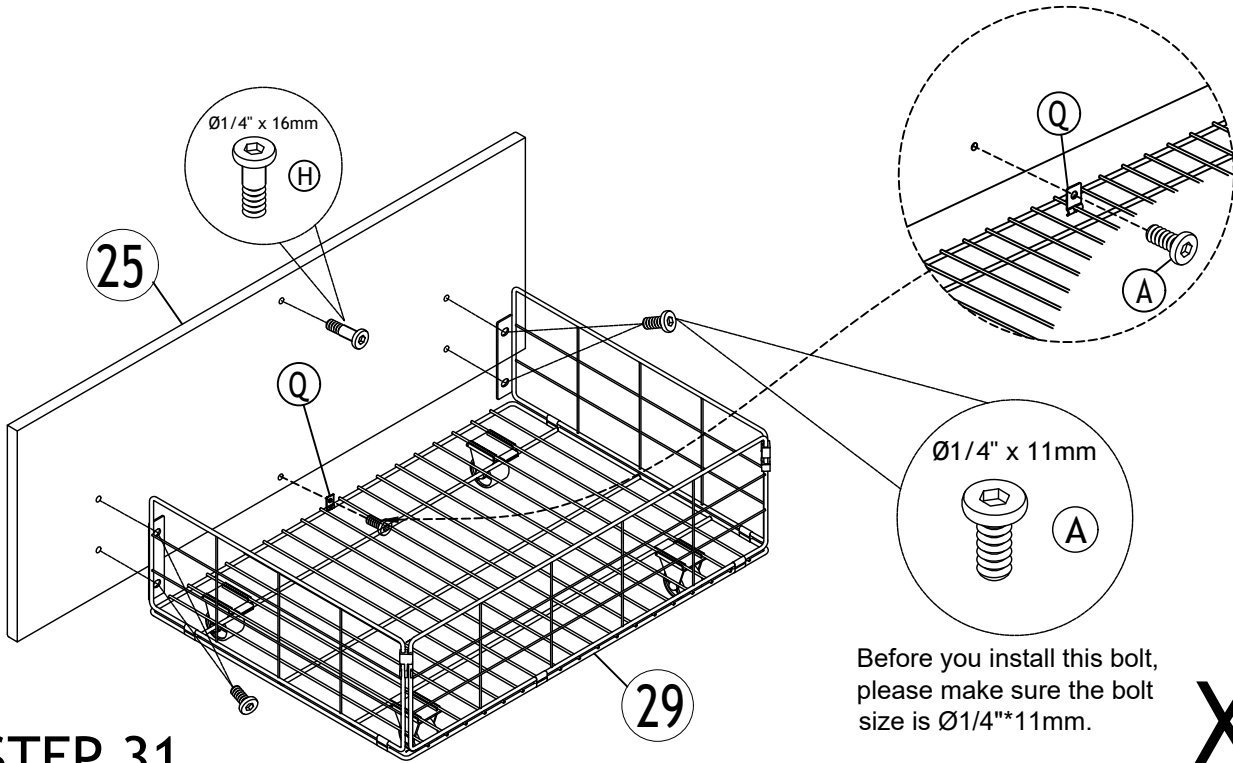
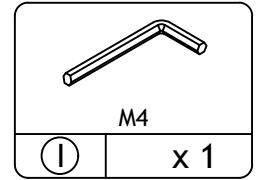
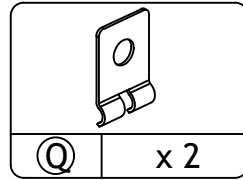
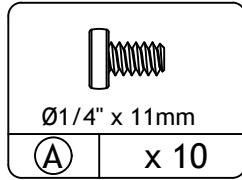
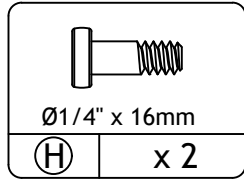

X2

STEP 31

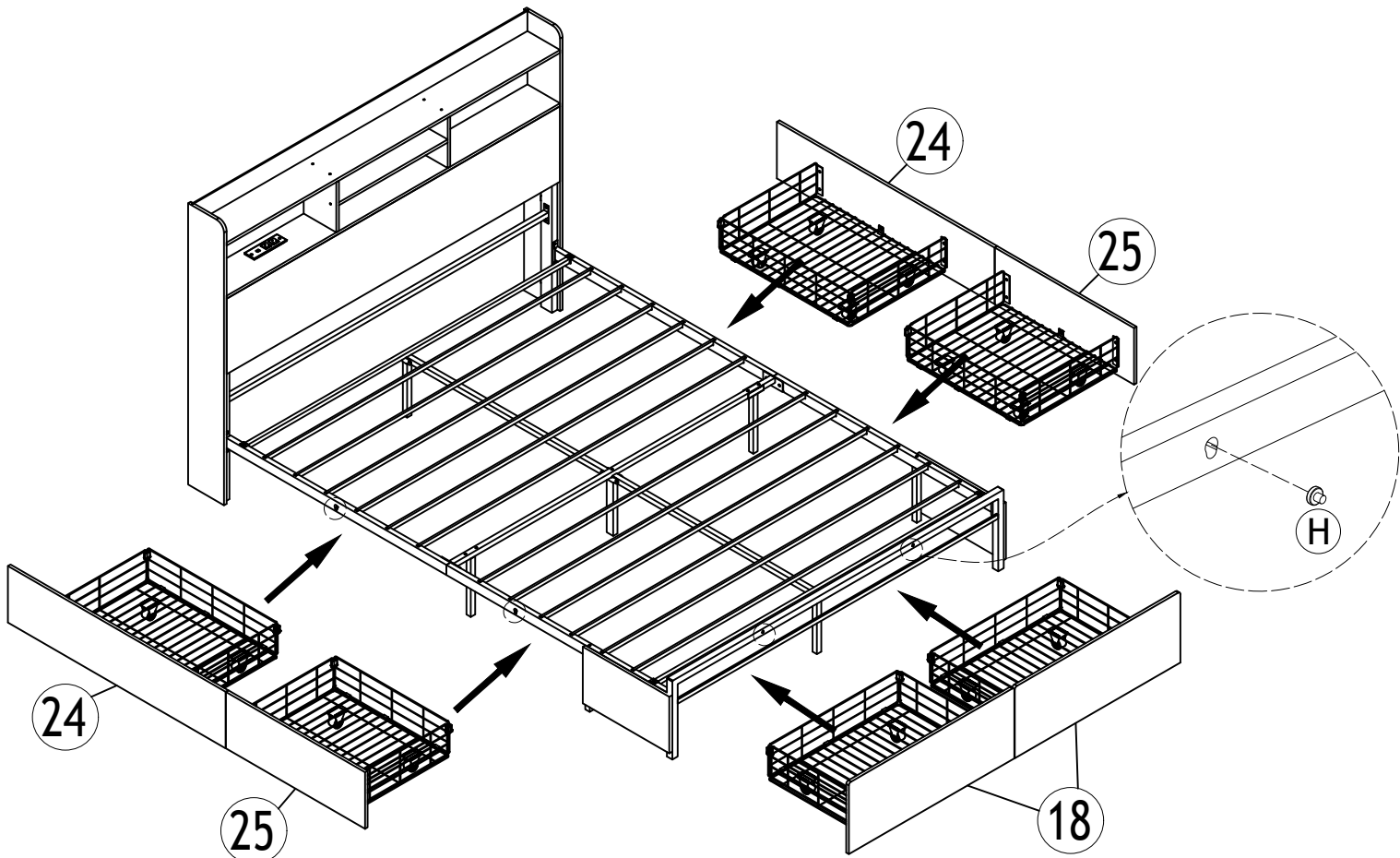

STEP 32

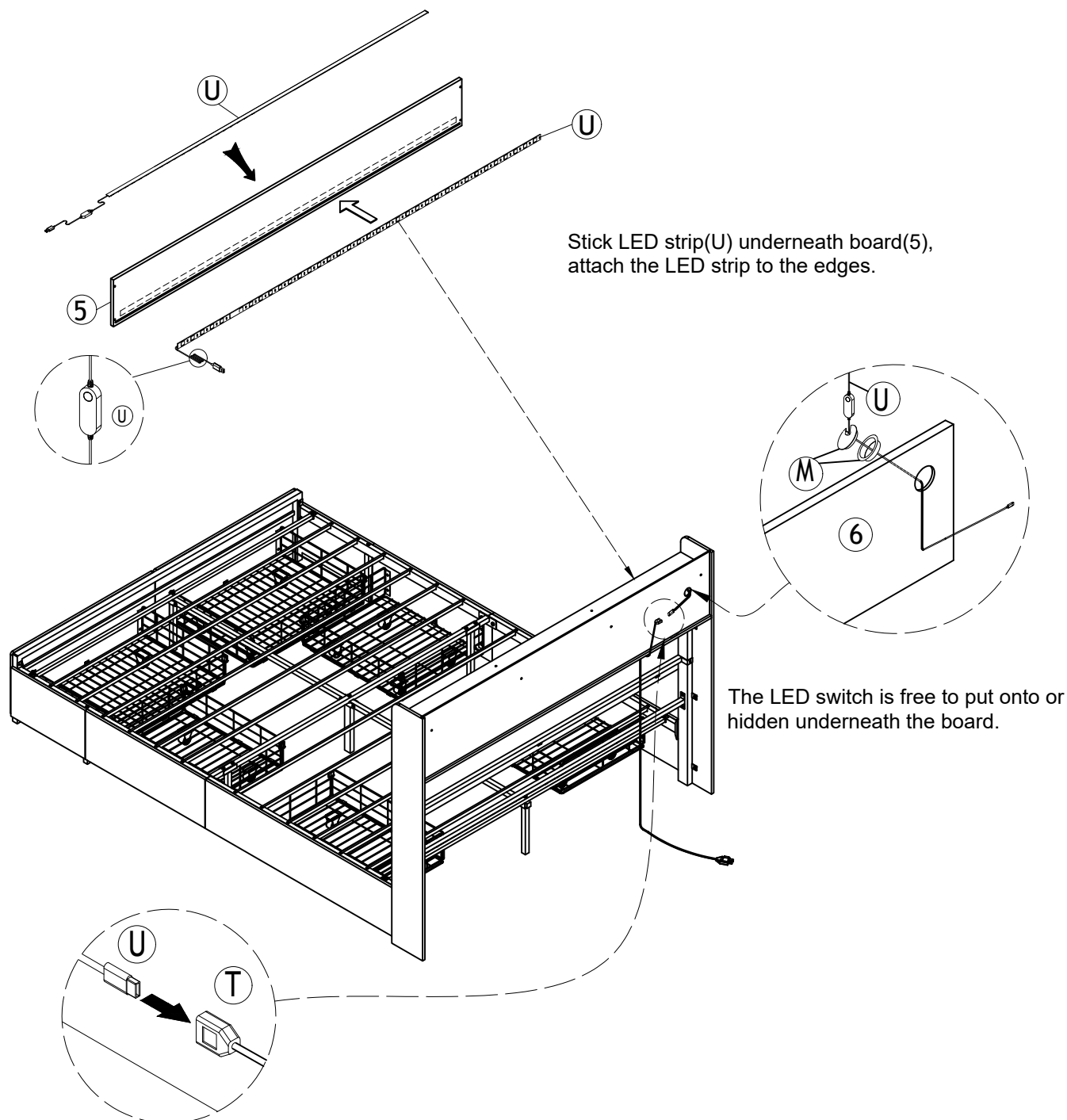
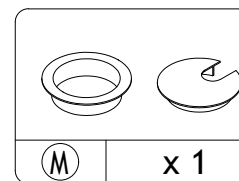
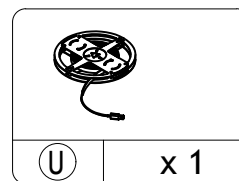



General Guidelines

- Please read the following instruction carefully and use the product accordingly.
- Please keep this manual and hand it over when you transfer the product.
- This summary may not include every detail of all variations and considered steps. Please contact us when further information and help are needed.

Notes

- The product is intended for indoor use only. The product must be assembled and used in accordance with the provisions of the manual. Personal injury and/or damage to product may occur if products are used outside of their intended purposes and/or if products have been changed/modified from their original design. The seller does not assume any responsibility or liability with respect to any injury/damage caused by incorrect assembly or improper use.
- Avoid long-term exposure to humid environments to prevent mildew.
- Keep the product away from fire sources and high temperatures. Do not expose the product to direct sunlight.
- Do not place any hot objects on the surface of the product.
- If there are any defective or missing parts after unpacking, please cease assembly immediately and contact us.
- Please assemble the item on a spacious surface and do not place the unwrapped product directly on the ground to avoid product damage.
- Please do not stand or sit on the wooden boards.
- Please wear gloves during the assembly and/or disassembly process to avoid scratches from any sharp edges.
- Please match the corresponding part and fitting based on the part number in the manual.
- If the part does not match with the fitting, please check the piece as specified in this manual.
- During assembly, first loosely align all screws with the corresponding pre-drilled holes and then tighten the screws one by one.
- Periodically inspect screw tightness while the product is in use. If necessary, retighten to ensure structural integrity.
- If you accidentally spill water or another liquid on the surface, immediately wipe clean with a dry towel.
- Please keep the product away from sharp, pointed objects and corrosive substances to prevent product damage.
- Please place this item on level, solid ground during use.

Warnings

- During assembly, keep all small parts out of the reach of children. It may be fatal if swallowed or inhaled.
- Children should not climb or play on the product in order to avoid tipping over the furniture and causing serious injury.
- To avoid the potential dangers of suffocation, please keep all parts and packaging (film, plastic bags, foam, etc.) away from babies and children.
- Keep sharp objects and corrosive items away from the product to avoid any damage or injury.
- Do not shake or move violently during use to avoid tipping over the product.